

Hydraulic Cylinder, Hoist

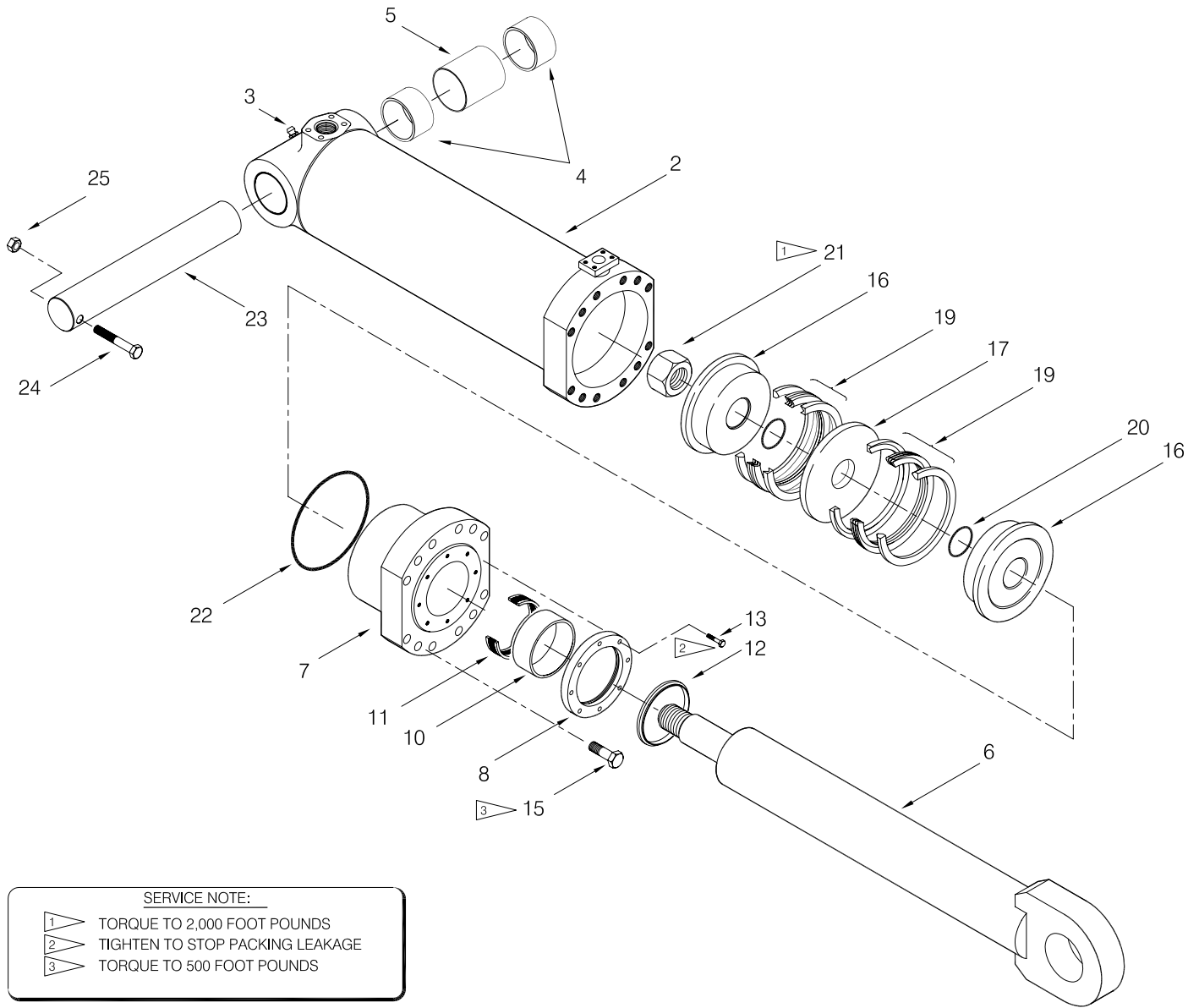

**SERVICE NOTE:**

- 1 TORQUE TO 2,000 FOOT POUNDS
- 2 TIGHTEN TO STOP PACKING LEAKAGE
- 3 TORQUE TO 500 FOOT POUNDS

Item	Part No.	Qty	Description	Item	Part No.	Qty	Description
<b>W11019 Hydraulic Cylinder, Hoist</b>							
1	572479	2	. Cylinder Assembly	15	234898	12	.. Capscrew
2	572481	1	.. Barrel & Base Assembly	16	568934	2	.. Piston
3	00191758	1	... Fitting	17	568935	1	.. Spacer
4	505568	2	... Bushing	19	* 566425	2	.. Packing
5	505570	1	... Spacer	20	* 203529	2	.. O-Ring
6	572482	1	.. Stem	21	234347	1	.. Nut
7	572774	1	.. Packing Gland	22	* 203565	1	.. O-Ring
8	562243	1	.. Retainer	23	567262	2	. Pin
10	573170	1	.. Bushing	24	R13801857	2	. Capscrew
11	* 572955	1	.. Packing	25	223587	2	. Locknut
12	* 228251	1	.. Wiper Ring				
13	239657	8	.. Capscrew	* Included in Service Kit 572953			