

Driveline Installation

Driveline Installation

Item	Part No.	Qty	Description	Item	Part No.	Qty	Description
	591309		Driveline Installation				
2	* 249023	1	. Driveline Assembly	47	563452	1	. Angle, Mounting
5	* 249014	1	. Driveline Assembly	51	Y17C-0624	8	. Capscrew
8	581908	1	. Bar, Guard	52	Y27E-06	16	. Washer
14	221563W	2	. Capscrew	53	223654	8	. Locknut
22	556580	1	. Plate, Guard	59	221777W	22	. Washer
23	557039	1	. Bracket	68	593730	1	. Plate, D'Line Guard
29	223188	10	. Locknut	69	563451	4	. Angle
30	Y17C-1236	8	. Capscrew	70	592183	1	. Bracket
36	221575W	16	. Capscrew	77	563885	2	. Shield
37	221771W	18	. Washer	78	221657W	2	. Capscrew
39	593651	1	. Bar, Mounting	79	Y17C-1232	2	. Capscrew
45	593652	2	. Pad, Tap				

* See Separate Coverage

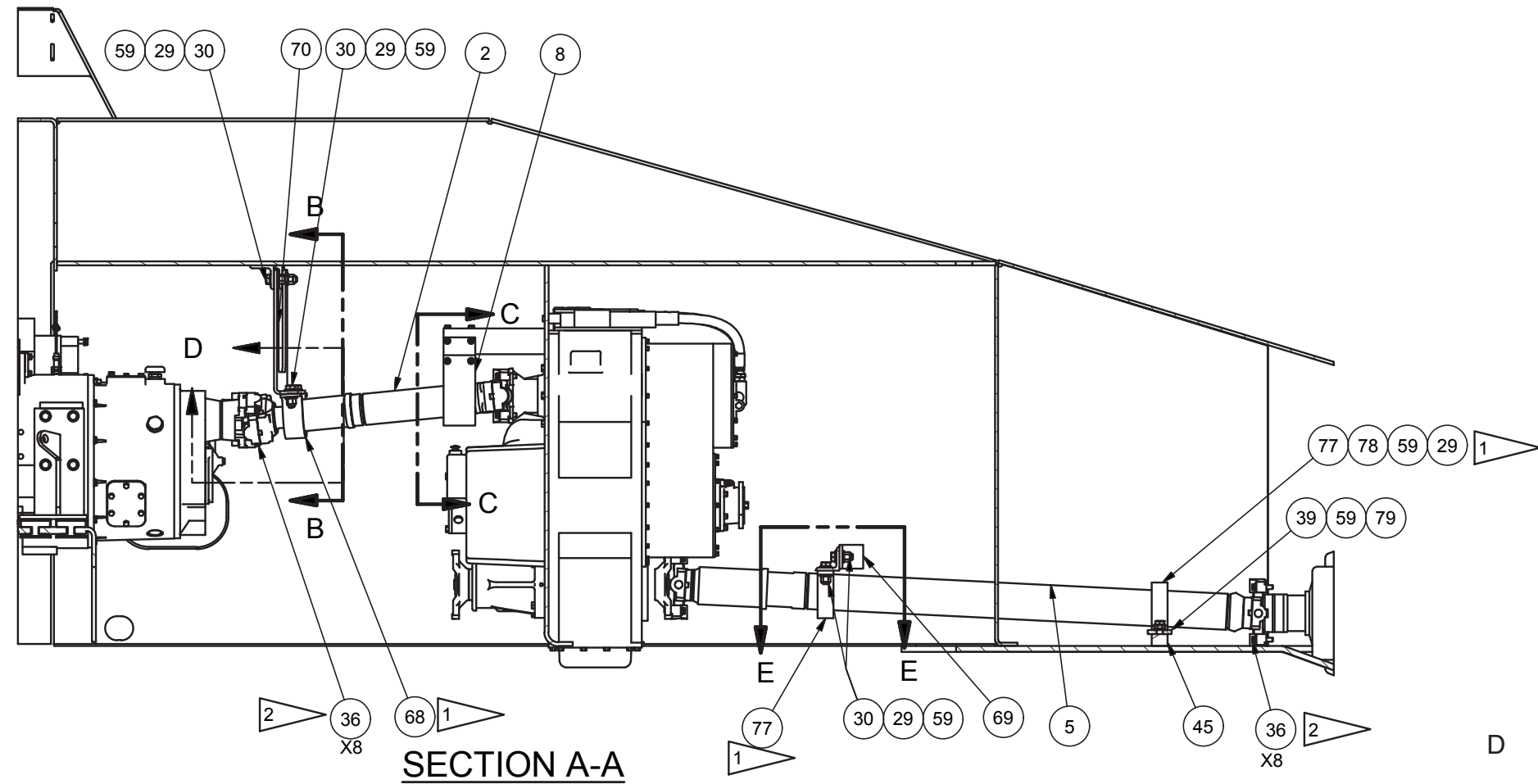
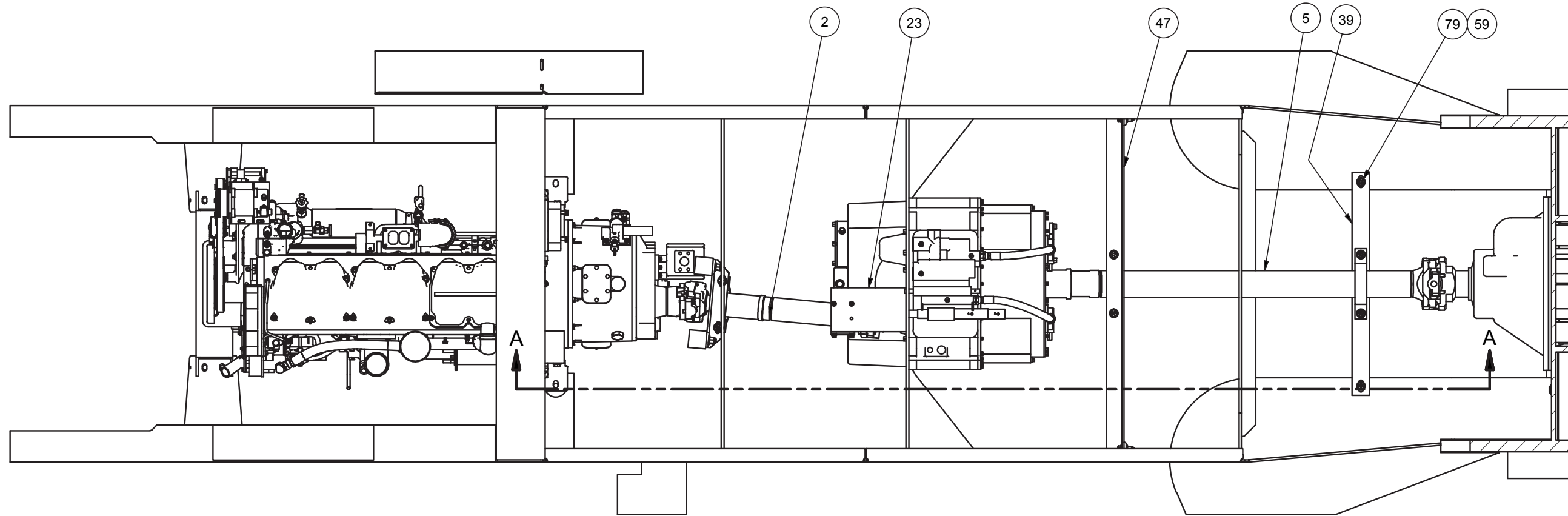

NOTES:

- 1 LOCATE DRIVELINE GUARD ASSEMBLY ON CENTERLINE OF DRIVELINE.
- 2 TORQUE ITEM 36 120 FT.LBS.

SECTION A-A

