

## Start & Stop Procedures

Before operating this machine, the operator must have: received operator training, a familiarity with this manual, and a complete understanding of all the procedures and functions that may be performed with this machine.

Planned maintenance and inspections are to be performed after the machine has been delivered, and prior to each shift. The operator should be aware of these procedures and be able to perform spot checks during operation.

**NOTE: These inspections may be performed by maintenance personnel or by the operator. In either case, it is the operator's responsibility to see that the machine is ready for operation prior to starting.**

Refer to the planned maintenance chart in Section 5 for a complete list of the daily checks that are to be performed.

### Engine Oil Level

The oil level should be checked prior to starting the engine. The dipstick and fill port are located just in front of the right hand side of the cab (see Figure 4-2-2).

**NOTE: A 15 minute drain-back time is recommended (if the engine has been running) to obtain an accurate reading.**

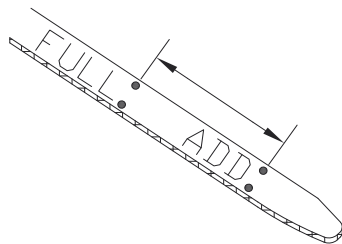
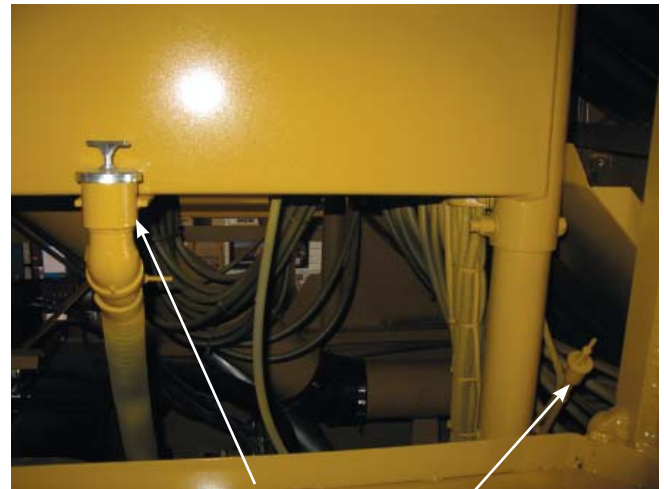

Figure 4-2-1 Typical Dipstick

The oil level must be maintained between the "L" (low) or "ADD" mark, and the "H" (high) or "FULL" mark. Maintain the oil level as close to the "H" or "FULL" mark as possible (see Figure 4-2-1).



Engine Oil Fill Tube

Engine Oil Dipstick

Figure 4-2-2 Engine Oil Maintenance Points



## CAUTION

Never operate the engine with the oil level below the "L" (low) mark, or above the "H" (high) mark. Refer to the engine's Operation and Maintenance manual for detailed engine service information.

Use only approved engine oil (see Lubricant Specifications Chart, Section 5). Do not overfill.

## Engine Coolant Level

Daily inspection of the coolant level is recommended. Cooling systems using anti aeration baffles restrict visual observation of the true coolant level. Even if the coolant can be seen, the system may not be full. To gain a true fill, add coolant slowly up to the bottom of the fill neck and allow a 30 second settling period.

**NOTE: If the engine is hot, the coolant level will be higher than when it is cold. Inspect the radiator daily for restriction caused by leaves, paper or other foreign material.**

The coolant reservoir sight gauge and fill cap are located just below the left hand cab door (see Figure 4-2-3). Coolant should be visible in the sight gauge at all times.

Inspect the radiator, cap, hoses, and connectors for any signs of leakage or damage.

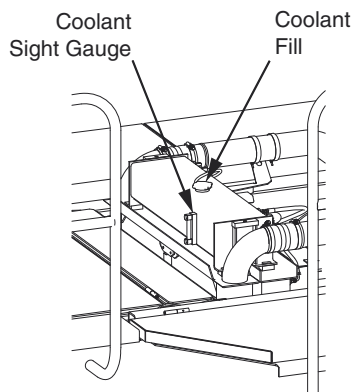

Figure 4-2-3 Coolant Check and Fill Location,



## WARNING

**Never remove the radiator cap if the engine is hot. The coolant will be under pressure and could flash to steam with explosive force, causing severe burns. Remove the radiator cap only when engine is cool.**

## Transmission Oil Level

The transmission dipstick and fill port are located just in front of the cab, on the left hand side (see Figure 4-2-4).

Always check the transmission oil level prior to starting the engine to be sure there is oil in the sump. The cold oil level must be above the "L" (low) mark on the dipstick.

The safe operation level should be checked after engine warm-up, with the transmission at normal oper-

ating temperature. Always check the operation level with the engine running, at operating temperature, with the transmission in neutral. The oil level should be between the "H" (high) and "L" (low) marks. Fill with approved fluid only (See Lubricant Specification Chart, Section 5).

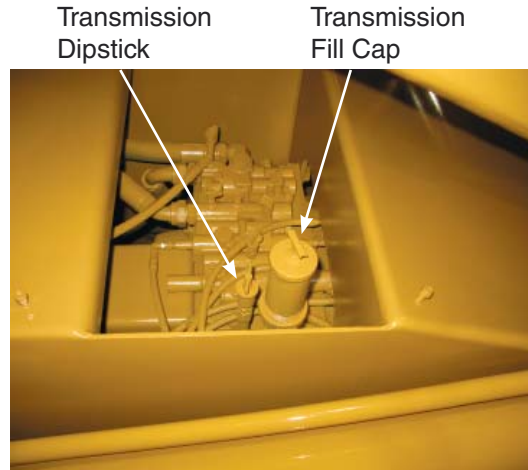

Figure 4-2-4 Transmission Check & Fill Location, Right Side of Chassis

## Fuel Level

Check the fuel gauge on the instrument panel at the beginning of each shift and throughout your shift. Never let the Logstacker run out of fuel!

Thoroughly read and adhere to the fuel recommendations found in your engine manufacturer's operation and maintenance manual.

The fuel fill cap is located on the left side of the chassis, to the rear below the deck (see Figure 4-2-5).

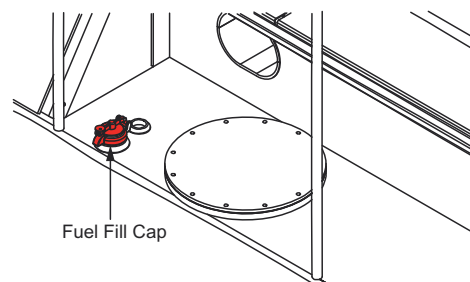

Figure 4-2-5 Fuel Fill Location,

## Hydraulic Oil Level

Always check the hydraulic oil level prior to operation. The oil level dipstick is located on the right-hand chassis deck (see Figure 4-2-6).

### **WARNING**

**Always open the tank breather petcock (located on the breather pipe) before removing the dipstick, filler cap or in-tank filter cover plate. Failure to vent tank can result in personal injury and / or a substantial oil spill. Be sure to close the petcock before operating the machine.**

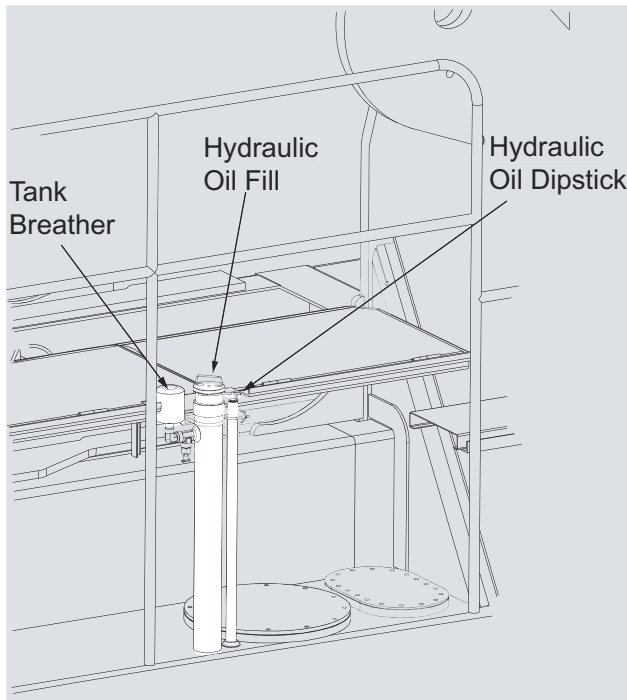

Figure 4-2-6 Hydraulic Oil Maintenance Locations (Right Hand Side of Chassis)

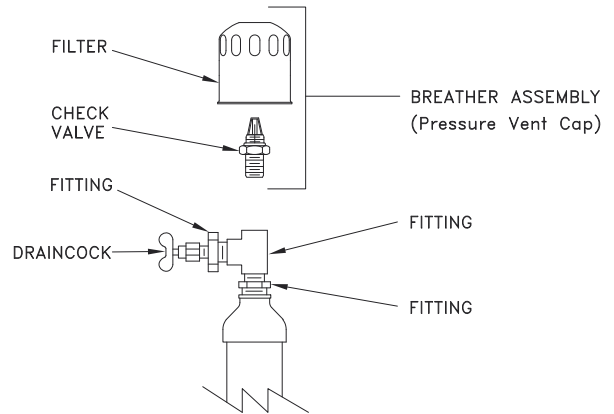

Figure 4-2-7 Tank Breather Assembly

The hydraulic oil level must be checked with the carriage in the normal park position (see Figure 4-2-8). The oil level should be at or near the “H” (high) mark on the dipstick. Fill with approved hydraulic fluid as required (See Lubricant Specifications Chart, Section 5). Do not overfill.

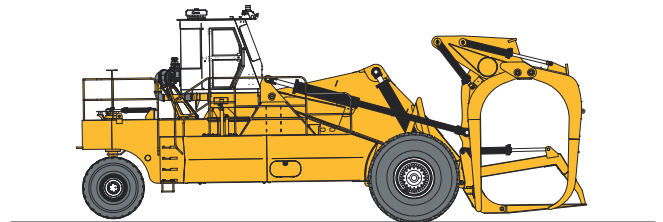

Figure 4-2-8 Normal Park Position (Carriage Tines Resting on the Ground, Kickoff Arms Retracted, Holddown Arms Touching the Ground)

## “Walk Around” Inspection

Perform a “walk around” inspection, looking for leaks, loose or missing fasteners, damaged hoses, structural cracks or damage, etc.

Also check for obstructed air passages and debris buildup in the engine compartment that could lead to over heating or fire hazards.

**DO NOT** operate the machine until all problems have been corrected!

## Tires

Visually inspect the tires for low air pressure and damage to the tread and side walls. If a tire appears suspect, appropriate maintenance personnel should thoroughly check it prior to operation.

## Engine Pre-Start

### NOTICE

*Thoroughly read, understand, and follow the engine manufacturer's operation and maintenance manual BEFORE attempting to start, operate, or shutdown the engine.*

*You will find all the information you need regarding proper engine break-in, starting & stopping procedures in the engine manufacturer's manual.*

*Failure to follow the engine manufacturer's procedures could result in: reduced engine performance, shortened engine life, engine damage, and/or voiding your engine warranty.*

Make sure that oil and coolant levels have been checked before attempting to start the engine.

Sit in your normal operating position and adjust the seat for your personal comfort. Wear your seat belt.

Check for parking brake engagement: Pull the knob to ensure the brake is set.

Place the transmission range selector in the "neutral" position, "N" on the gear quadrant.

**NOTE: All current Wagner units are equipped with a neutral start switch which prevents the engine from starting unless the transmission is in neutral.**

Give warning that you are going to start the engine. Make sure that all personnel are clear of the machine, as you may not be able to see them from the cab. Be sure that the area around the machine is clear of all obstructions.



### WARNING

**Do not start the engine if the key switch has been tagged with a "Do Not Start" or "red" tag, or by your local "lockout/tagout" procedure.**

Turn the key switch to the ON position. The parking brake light and panel lights should come on.

The Red Shutdown/Derate LED, located on the Power View Screen (see Power View Display Module in section 2), when illuminated, indicates the need to stop the engine as soon as can be safely done. The engine must remain shut down until the fault can be repaired.

The Amber Warning LED, located on the Power View Screen (see Power View Display Module in section 2), when illuminated indicates, the need of repair at the first available opportunity.

### NOTICE

*Do not depress the accelerator pedal or move the accelerator lever from the idle position while cranking the engine. This can result in engine overspeed and severe damage to the engine.*

### NOTICE

*To prevent damage to the starting motor, do not engage the starting motor for more than 30 seconds. Wait 2 minutes between each attempt to start.*

## Starting the Engine

Start the engine according to your engine manufacturer's operation and maintenance manual procedures.

**NOTE: If the engine does not start after three attempts, check the fuel supply system. Absence of blue or white exhaust smoke during cranking indicates no fuel is being delivered.**

Allow the key switch to return to the RUN position after the engine starts.

Follow your engine manufacturer's operation and maintenance manual procedures for engine warm-up.

**NOTE: For maximum engine protection and easier starting:**

- Keep the batteries fully charged.
- Keep the fuel clean and free of water.
- Change the engine oil to the recommended viscosity for the air temperature.

## Temperatures below 0° F/-18° C

If the machine will be shut down for several hours or longer with ambient temperatures below 0° F/-18° C, the hydraulic tank heater (Optional) should be plugged in as soon as the machine is shut down. This will help to maintain hydraulic oil temperature.

## NOTICE

*If the temperature of the hydraulic oil is below its pour point, or 0° F/-18° C, do not start the engine. The high oil viscosity could cause immediate pump cavitation, resulting in severe damage. In this case, the oil in the hydraulic tank must be heated prior to engine start-up.*



## WARNING

The optional hydraulic tank heater uses a 220 or 110 VAC external power source. Be sure to connect the heater to the proper source with correct voltage. An electrical shock could be fatal. Don't forget to disconnect the heater cable before beginning operation. All electrical cables and connectors must be in good condition. Use caution in wet weather to avoid danger from electric shock. All connections to the heater must be properly grounded.

---

## Hydraulic System Operating Temperature

If hydraulic oil is above 0° F/-18° C, starting the engine should do no harm to the hydraulic system. After starting the engine, the oil temperature will increase as the hydraulic pump cycles the oil while the engine is warming up.

When the hydraulic oil is above 32° F/0° C and the engine has completed its warm up:

1. Bring the engine to 1500 rpm, either with the hand throttle or with the use of the foot pedal throttle.
2. Function all implements through the full range of motion 5 times each. This should warm the oil sufficiently enough for operation.
3. If the ambient temperature is below 32° F/0° C, you may need to take extra steps to raise the hydraulic oil to the minimum working temperature of 70° F/20° C. It may be necessary to bottom out one of the hydraulic function cylinders (preferably the hoist or tilt cylinders) and continue to command it to operate past its limit. This will pass oil through the relief valve, thus generating more heat.
4. Once the hydraulic fluid is above 70° F/20° C, the Logstacker is ready to go to work.

## Engine Shutdown

Consult your engine manufacturer's operation and maintenance manual procedures for proper engine shutdown.

### **NOTICE**

*Except in emergencies, never shut the engine down immediately after operation. Allow the engine to idle for three to five (3 - 5) minutes before shutting it down. Failure to do this could cause engine damage.*

While the engine is cooling down at idle: place the machine in the normal park position (see Figure 4-2-8 on page 4-2-3), set the parking brake, place the transmission in neutral.

To stop the engine, turn the key switch to the OFF position.