

wagner

A Division of Allied Systems Company

LC90

Purpose-Built Landfill Compactors



- Front chassis oscillation 15° each way
- Large cab w/ air ride seat, optional trainer's seat, and joystick steering
- Double reduction planetary axles
- Choice of wheel and cleat design (optional wheel cleaners)
- Rugged durability with chassis and components designed for long life



MADE IN USA

Made in the USA

Wagner has been manufacturing material handling and dozing equipment in the Portland, Oregon area for more than 50 years. Machines greater than 30 years old are still operating as front-line production machines. They are testimony to the high quality and durability Wagners are known for. Now, Wagner brings that same performance and durability to the landfill market with the new **LC90**.

Unmatched Comfort

With 30 degrees of front frame oscillation, all four wheels are always on the ground, giving the operator the best possible ride while providing maximum compaction. And with an ergonomic heavy duty seat, suspension, and electronic controls, the Wagner Landfill Compactor keeps the operator safe, comfortable and alert; the highest priority for any operation. Ergonomic controls prevent fatigue and large windows allow for maximum visibility.



Durable and Reliable – Designed for Long Life

Using a purpose-built machine results in longer component life and longer intervals between rebuilds. Wagner's time-tested chassis design holds up to the toughest environments, reducing down-time and increasing productivity.

Features

Structures

- High mounted steering cylinders to avoid damage from debris
- ROPS and FOPS Certified Canopy
- Sealed to Prevent Debris Accumulation
- Hydraulically Actuated Belly Pans for Easy Service Access

Power Train

- Three Stage Air Cleaner (Pre-Cleaner, Primary and Secondary Filter)
- Easy Swing-Away Door to Reversible Cooling Fan
- Engine De-Rate/Shutdown Capabilities
- Double Planetary Reduction Axles
- Forced Cooled Wet Disc Brakes, Rear Axle
- Spring Applied Hydraulic Released Parking Brake
- Engine Compartment Access (Doors/Panels)
- Limited Slip Front Differential, No-Spin Rear Differential

Guards

- Axle (Front and Rear)
- Extra Fuel and Oil Tank Protective Plating
- Underbody
- Rear Cooling Fan

Wheels

- Customized Cleat Configurations
- Choice of Cleat Styles

Blade

- Straight or Semi-U
- Designed For Refuse Handling
- Reversible Cutting Edge
- Cut-Outs For Visibility
- Double Acting Lift Cylinder
- Optional Blade Float Control

Electrical

- Backup Alarm
- Forward and Rear Facing LED lights

Operator Environment

- Hand Throttle Control
- Wagner Smart Screen Display
- Windshield Wipers and Washer
- Air Conditioner
- Heater and Defroster
- 12V Power Converter with Outlet
- Filtered, Pressurized Fresh Air Inlet
- Cupholder
- Coat/Hardhat Hanger
- Tinted Safety Glass
- 2 Point Lap Seat Belt
- Ergonomic Heavy Duty Operators Seat
- Operator Seat Air Suspension
- Adjustable Operator Control Consoles
- Radio with MP3 Player, Bluetooth
- Electric Horn
- Optional Rear View Camera with Monitor
- Optional Trainers Seat
- Full Walk-Around Platform With Platform Egress
- Optional Remote Monitoring System

Serviceability

- Central/Auto Lube System
- Ground Level Hydraulic Sight Gauge
- Ground Level Fuel Fill

LC90

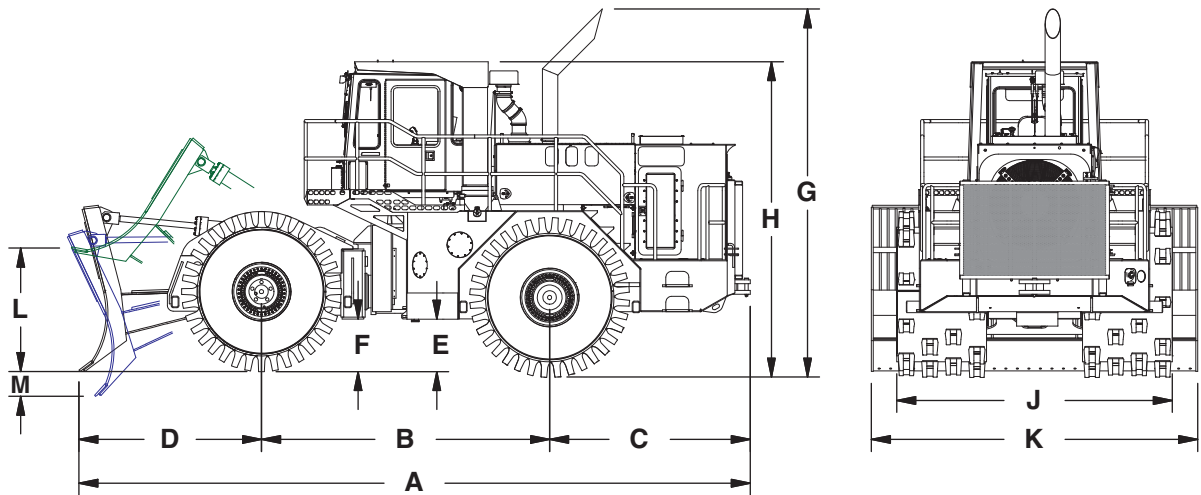

Dimensions

A. Length with Blade on Ground (straight blade).....	29' 2"
B. Wheelbase	12' 6"
C. Center Line of Rear Axle to Rear	8' 9"
D. Center Line of Front Axle to Front of Blade.....	7' 11"
E. Ground Clearance.....	2' 3"
F. Ground Clearance under Bogie	2' 3"
G. Height to Top of Exhaust Pipe.....	16' 0"
H. Height to ROPS/Canopy	13' 8"
J. Width over Wheels	12' 0"
K. Blade Width	14' 2"
L. Maximum Blade Height above Grade	5' 4"
M. Minimum Blade Height below Grade	13"

Wheels:

Drum Width.....	3' 11"
Drum Diameter	5' 7"
Diameter with Teeth	6' 11"
Cleats Per Wheel	36

Articulation Angle.....	40 Degrees Each Way
Oscillation	15 Degrees Each way

Weight

Operating Weight.....	90,000 lb
-----------------------	-----------

Specifications

Engine

Model.....	Cummins QSL9
Horsepower	430 HP @ 2,100 rpm
Max Torque	1,361 ft-lbs @ 1,500 rpm
Bore and Stroke.....	4.5" x 5.7"
No. of Cylinders	6
Displacement.....	543 Cu/In (8.9 liters)
Maximum Operating Slope	3:1

2 Speed Forward and Reverse Modulated

Automatic Transmission

1st	3.3 mph
2nd.....	6.0 mph

Capacities

Fuel Tank	190 gals
DEF Tank	25 gals
Hydraulic Oil	110 gals
Crankcases.....	12 gals
Cooling Systems.....	20 gals



Allied Systems Company was founded in 1976 as a fabricator of material handling equipment for the wood products industry. Since that time, Allied has expanded greatly and now owns several different product lines, including Allied Marine Crane, Allied Winch, Wagner Chip Dozer, Wagner Coal Dozer, Wagner Lumberjack, Wagner Landfill Compactor, Wagner Steel Handler, Long Reach Attachments, and Freeman Hay Handling Equipment.

Allied's skilled engineering and manufacturing teams have the capability to build custom equipment and vehicles to your design, or we can design the equipment for you, to your exact standards.

Factory Contact Information

wagner

A Division of Allied Systems Company

21433 S.W. Oregon Street
Sherwood, Oregon 97140 USA
Telephone: 503.625.2560 • Fax: 503.625.7980
E-mail: wagner@alliedsystems.com
www.alliedsystems.com

Dealer Contact Information



SUN MACHINERY COMPANY

P.O. Box 789, Lexington, SC 29071

P.O. Box 1240, Tioga, LA 71477

803/359-1000

318/640-8820