

Hydraulic Pump

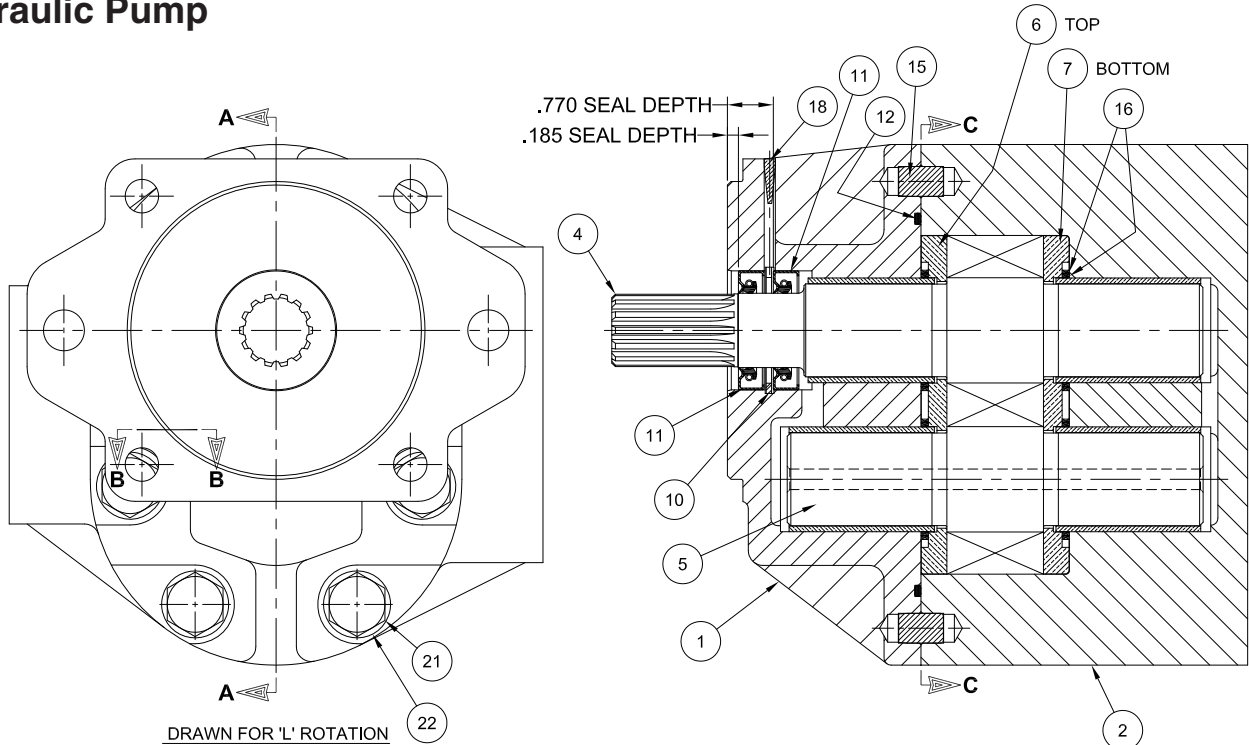

SECTION A-A

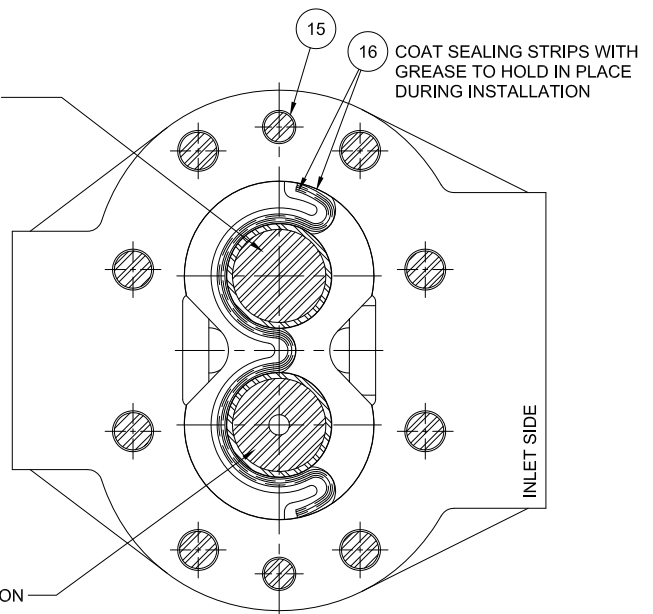
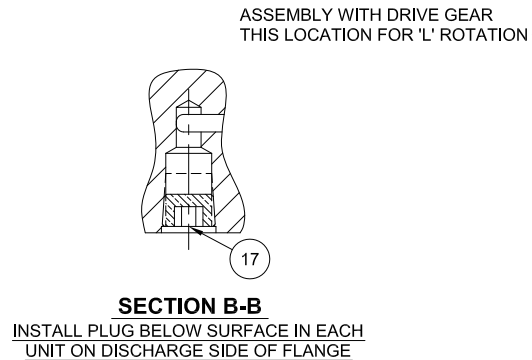

SECTION C-C

Item	Part No.	Qty	Description	Item	Part No.	Qty	Description
	254840		Hydraulic Pump				
1	255045	1	. Flange	12	* 255049	1	. O-Ring
2	255046	1	. Body	15	* 246768	2	. Dowel
4	255047	1	. Drive Gear	16	* 255050	4	. Sealing Strip
5	255048	1	. Idler Gear	17	* 246767	1	. Plug
6	* 246765	1	. Pressure Plate	18	* 251548	1	. Plug
7	* 246766	1	. Pressure Plate	21	* 248184	8	. Capscrew
10	* Y435241.038	1	. Snap Ring	22	* 246769	8	. Washer
11	* 251547	2	. Seal				

* Included in Sub-Assembly Kit 255051