

Shift Valve Module - 24V

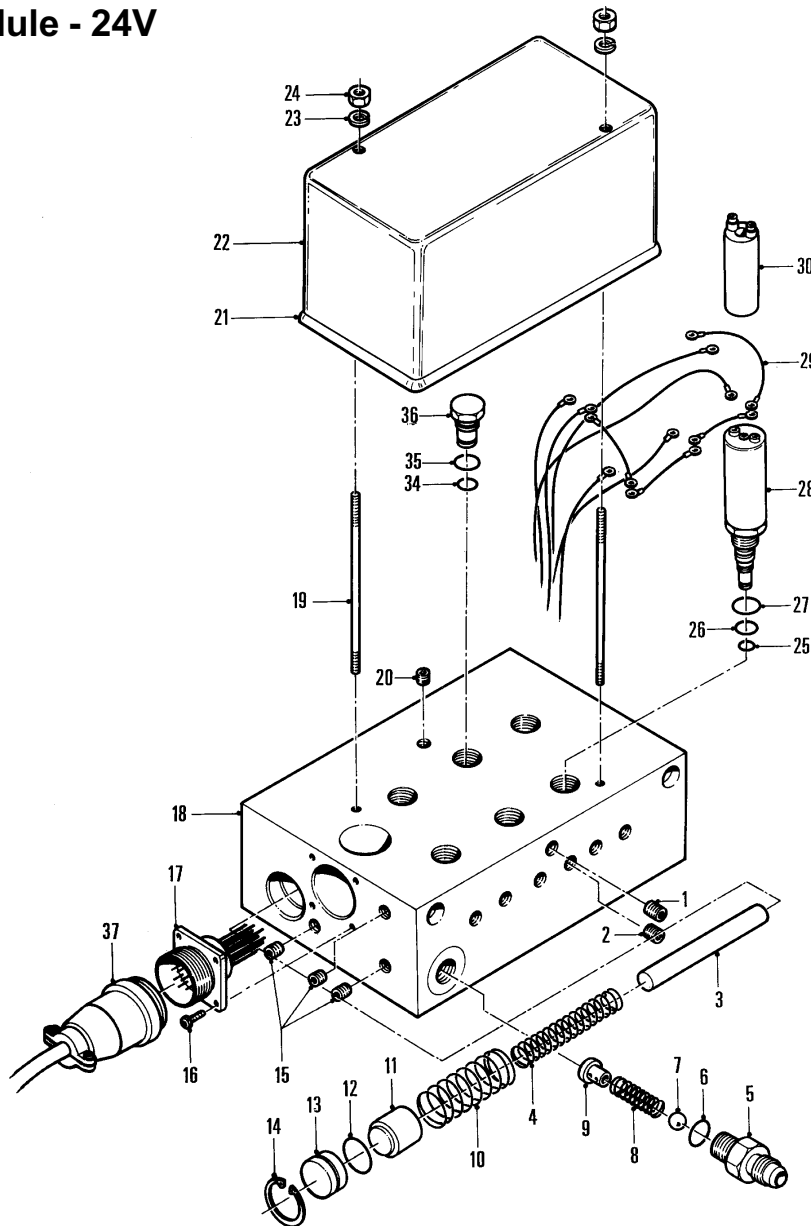

Item	Part No.	Qty	Description	Item	Part No.	Qty	Description
	232904		Shift Valve Module-24V				
1	232076	1	. Pipe Plug	20	227825	1	. Pipe Plug
2	232076	1	. Pipe Plug	21	232080	1	. Seal
3	219853	1	. Pin, Piston Stop	22	232081	1	. Dust Cover
4	219855	1	. Spring	23	R13800826	2	. Lockwasher
5	219864	1	. Check Valve	24	00103024	2	. Nut
6	232077	1	. O-Ring	25	*a 232082	5	. O-Ring
7	200637	1	. Ball	26	*a 232083	5	. O-Ring
8	219863	1	. Spring	27	*a 232084	5	. O-Ring
9	219862	1	. Control Pin	28	*a 233072	5	. Solenoid Valve Assembly
10	219856	1	. Spring	29	240225	4	. Interconnect Wire
11	219857	1	. Piston	30	*a,*b 237469	5	. Coil (Black Plastic)
12	201207	1	. O-Ring	30	*a,*b 243575	5	. Coil (Aluminum)
13	212546	1	. Retaining Plug	34	232087	1	. O-Ring
14	232078	1	. Snap Ring	35	232088	1	. O-Ring
15	227825	3	. Pipe Plug	36	232089	1	. Plug
16	240222	4	. Screw	37	-----	1	Plug & Wire Asm -See Junction Box 6-2
17	232079	1	. Receptacle & Wire Asm				
18	240223	1	. Manifold				
19	240224	2	. Mounting Stud				
				*a	Included with item 28		
				*b	Either Black Plastic Coil or Aluminum Coil is used. Coils are not Interchangeable. See WAGNER Service Bulletin 0351.		