



MODEL 7000
PULL TYPE BALE WAGON

PARTS MANUAL

PB00700014

A Product of

Allied Systems
COMPANY

Sherwood, Oregon USA

S/N: ASC-7000-005 to Current



Important: Be certain to specify the serial number of your Bale Wagon when ordering parts.

Safety

Allied Systems Co. is concerned with safety. Freeman Equipment is furnished with safety features. Even with these safety features, personal injury can still occur if the operator is careless when operating or maintaining the machine. There are "CAUTION," "DANGER," and "BE CAREFUL" decals on the machine. Read and pay attention to the decals. Following is a list of precautions that should be taken to help prevent personal injury:

- Keep all shields in place.
- Shut off tractor engine before adjusting, lubricating, cleaning or servicing the bale wagon.
- Wait for all movement to stop before servicing bale wagon.
- Keep hands, feet, and clothing away from power driven parts.
- Keep all shields installed and keep clear of the P.T.O.
- Keep all others off the bale wagon.
- Use appropriate signs or warning lights when operating on highways.
- Make certain everyone is clear of the bale wagon before engaging P.T.O.
- Do not ride on any part of the bale wagon.
- Keep hands and feet clear of drive chains.
- Periodically check all nuts and bolts for tightness.
- Always use lights for night work.
- As a safety precaution it is recommended that an "abc" fire extinguisher be carried on the bale wagon at all times. It is also recommended to carry a four gallon water container with pump, or as required by local and state law.
- Avoid loose clothing which can easily be caught in moving parts.
- Remember 'safety' is only a word until it is put into practice.



WARNING

Some illustrations in this operator manual show the bale wagon without shields to allow for a better view of the area being addressed. The bale wagon should never be operated with any of the safety shields removed.

NOTE: Illustrations are for "ordering" information only, and are not intended for use as an assembly guide.

Introduction

HOW TO USE THE MANUAL

This manual contains illustrations and parts lists of components and assemblies which make up the machine. Each page consists of the name of the assembly or component, a reference number, part number, quantities of the part used and the part name.

Assembly or component names help identify the illustration and parts list for each figure. This name also helps locate the general area of the machine where the assembly or component can be located.

Reference numbers shown in a column refers to the numbered parts in the illustration. This ties the part in the illustration to the part number and description in the parts list. Part numbers are used to identify individual parts or part assemblies

Part descriptions provide the name of the part, plus additional information such as dimensional specification and what parts are grouped together to form part assemblies, which helps you identify the parts.

Quantities listed for each illustration are only for that assembly or component and not the total used per machine.

Indent dots are used to indicate assemblies and sub-parts of assemblies. No dot indicates the major assembly. Part descriptions which are indented with dots are sub-parts of the major assembly shown above.

Parts pages will be revised as necessary to show the latest parts information. Revision information will be on the bottom of the page

This parts manual is not intended to be a complete guide for machine service or repairs. Contact your dealer for any of your service or technical requirements.

UPDATING AND REORDERING MANUALS

The parts lists, illustrations and specifications in this manual are based on the latest information available at the time of publication. Your machine may have product improvement and options not yet contained in this manual.

A copy of this manual is supplied with each machine. Additional copies are available through your dealer. When ordering additional manuals, use the reorder number listed on the front cover and the quantity needed.

BOLT TORQUE - GRADE 8 COARSE THREAD

BOLT SIZE	NON PLATED (lb-ft)	ZINC PLATED (lb-ft)	LUBRICATED (lb-ft)	CADMIUM PLATED (lb-ft)	NEVER - SEIZE (lb-ft)
1/4	14	9	8	7	6
5/16	29	19	17	16	12
3/8	52	35	31	28	221
7/16	84	56	50	45	33
1/2	129	86	77	69	51
9/16	187	124	112	100	75
5/8	258	172	155	138	103
3/4	463	309	278	247	185
7/8	751	501	451	400	300
1	1128	752	677	602	451
1 1/8	1596	1064	958	851	638
1 1/4	2227	1518	1366	1215	911
1 3/8	2967	1978	1780	1582	1187
1 1/2	3974	2649	2384	2119	1590
1 3/4	6249	4166	3750	3333	2500
2	9419	6280	5652	5024	3768
2 1/4	13927	9285	8356	7428	5571
2 1/2	19033	12689	11420	10151	7613
2 3/4	26040	17360	15624	13888	10416
3	34584	23056	20750	18445	13834

Bale Wagon Serial Number & Parts Ordering Information

Each Freeman Bale Wagon is identified by means of a model number and serial number. The serial number is an important piece of information about the machine and it may be necessary to know it before obtaining the correct replacement part. The serial number is located on the left front frame. To ensure prompt, efficient service when ordering parts or requesting repairs from your authorized Freeman dealer, record the serial numbers in the spaces provided.

BALE WAGON SERIAL NUMBER

Left front side of bale wagon.

NOTE: Reference to left-hand and right-hand used throughout the manual are understood to mean from a position facing in the direction of travel.

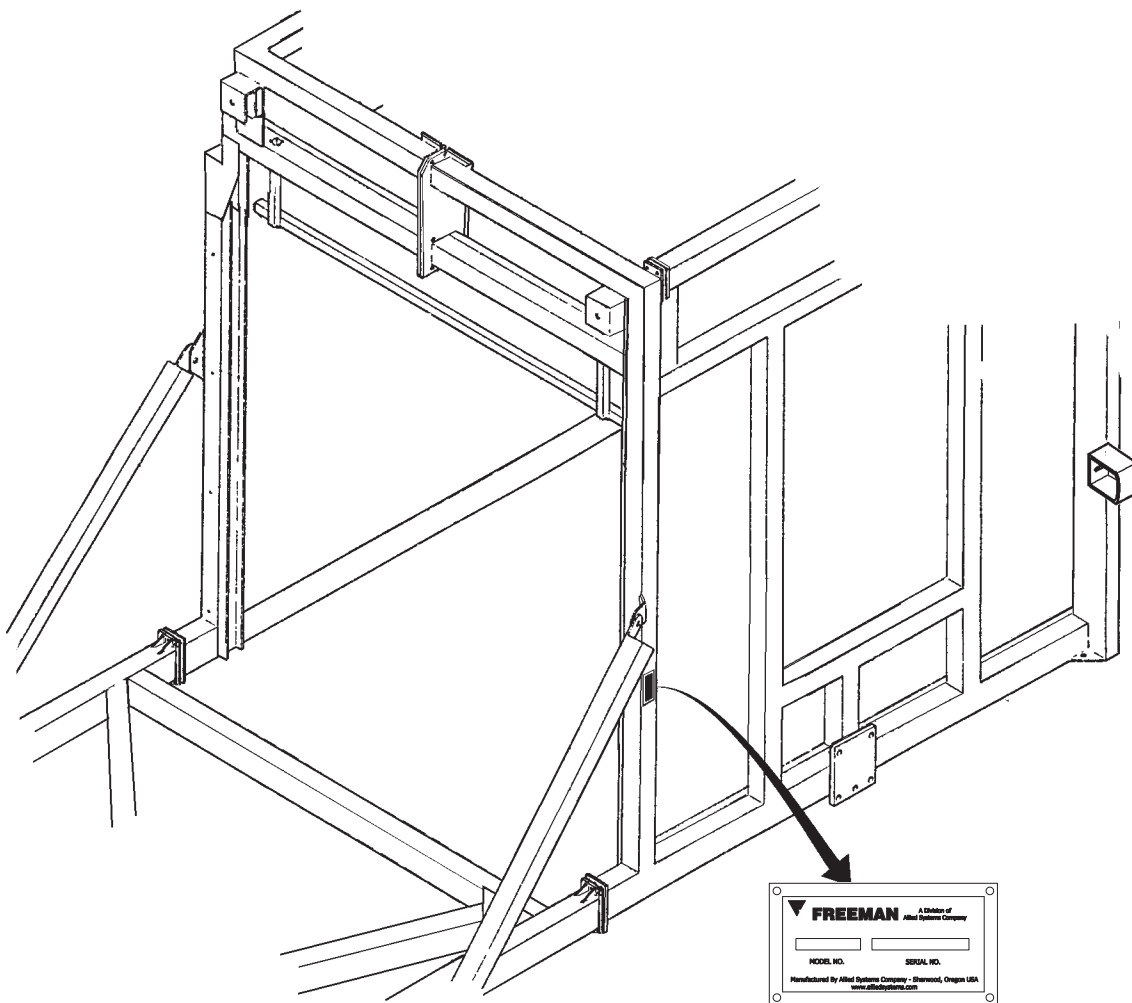

Serial Number Plate located on left front frame of bale wagon.

This manual applies to the following bale wagon serial numbers: S/N ASC-7000-004

For any further information on parts, service or ordering, consult your local Freeman dealer.

Alphabetical Index

Bale Retainer Assembly	63
Bale Retainer Installation	61
Bale Table Installation.....	47
Control Box Assembly	69
Cylinder Head Assembly	41
Cylinder Installation	81
Decal Installation.....	115
Drawbar Receptacle Installation.....	13
Electrical Junction Box Assembly.....	67
Elevator Assembly.....	27
Elevator Installation	23
Frame Assembly.....	9
Hitch Assembly.....	11
Hydraulic Hose & Tube Installation.....	85
Hydraulic Manifold.....	77
Hydraulic Manifold Assembly	75
Hydraulic Tank Assembly	79
Index Paddle Assembly	103
Introduction	3
Lights Installation	111
Limit Switch Assembly, LS: 1, 8, 9, 14, 15 (N.C.)	105
Limit Switch Assembly, LS: 2-7, 10-12, 16 (N.O.).....	109
Limit Switch Assembly, LS-13 (N.C.).....	107
Limit Switch Installation, LS: 2-6, 10-13, 16	97
Limit Switch Installation, LS-15, Push Off	43
Limit Switch Locations.....	95
Load Bed Installation.....	31
Manifold Assembly	93
Manifold & Tank Installation.....	71
Panel Assembly.....	65
Parts Index	120
Pickup Assembly	19
Pickup Installation	17
Pusher Assembly Installation	55
Roller Mount Assembly	45
Safety	2
Safety Gate Installation	53
Table of Contents	6
Tie Arm Installation	57
Wheel Installation.....	15

Table of Contents

Safety	2
Introduction	3
Frame Assembly.....	9
. Hitch Assembly	11
.. Drawbar Receptacle Installation.....	13
. Wheel Installation	15
Pickup Installation	17
. Pickup Assembly.....	19
Elevator Installation	23
. Elevator Assembly	27
Load Bed Installation.....	31
. Cylinder Head Assembly	41
. Limit Switch Installation, LS-15, Push Off.....	43
.. Roller Mount Assembly.....	45
Bale Table Installation.....	47
Safety Gate Installation	53
Pusher Assembly Installation	55
. Tie Arm Installation.....	57
Bale Retainer Installation	61
. Bale Retainer Assembly	63

Table of Contents (cont...)

Panel Assembly.....	65
. Electrical Junction Box Assembly	67
. Control Box Assembly.....	69
Manifold & Tank Installation.....	71
. Hydraulic Manifold Assembly.....	75
.. Hydraulic Manifold.....	77
. Hydraulic Tank Assembly.....	79
Cylinder Installation.....	81
Hydraulic Hose & Tube Installation.....	85
. Manifold Assembly.....	93
Limit Switch Locations.....	95
. Limit Switch Installation, LS: 2-6, 10-13, 16.....	97
.. Index Paddle Assembly	103
.. Limit Switch Assembly, LS: 1, 8, 9, 14, 15 (N.C.)	105
.. Limit Switch Assembly, LS-13 (N.C.).....	107
.. Limit Switch Assembly, LS: 2-7, 10-12, 16 (N.O.).....	109
Lights Installation	111
Decal Installation.....	115
Parts Index	120

SCHEMATIC PACK:

Hydraulic Schematic, Manifold - 906563

Wire Harness Schematic - 904913

Control Box Harness - 904951

Junction Box Wire Harness - 904981

Electrical Schematic - 905102

Switch wiring - 904982

Frame Assembly

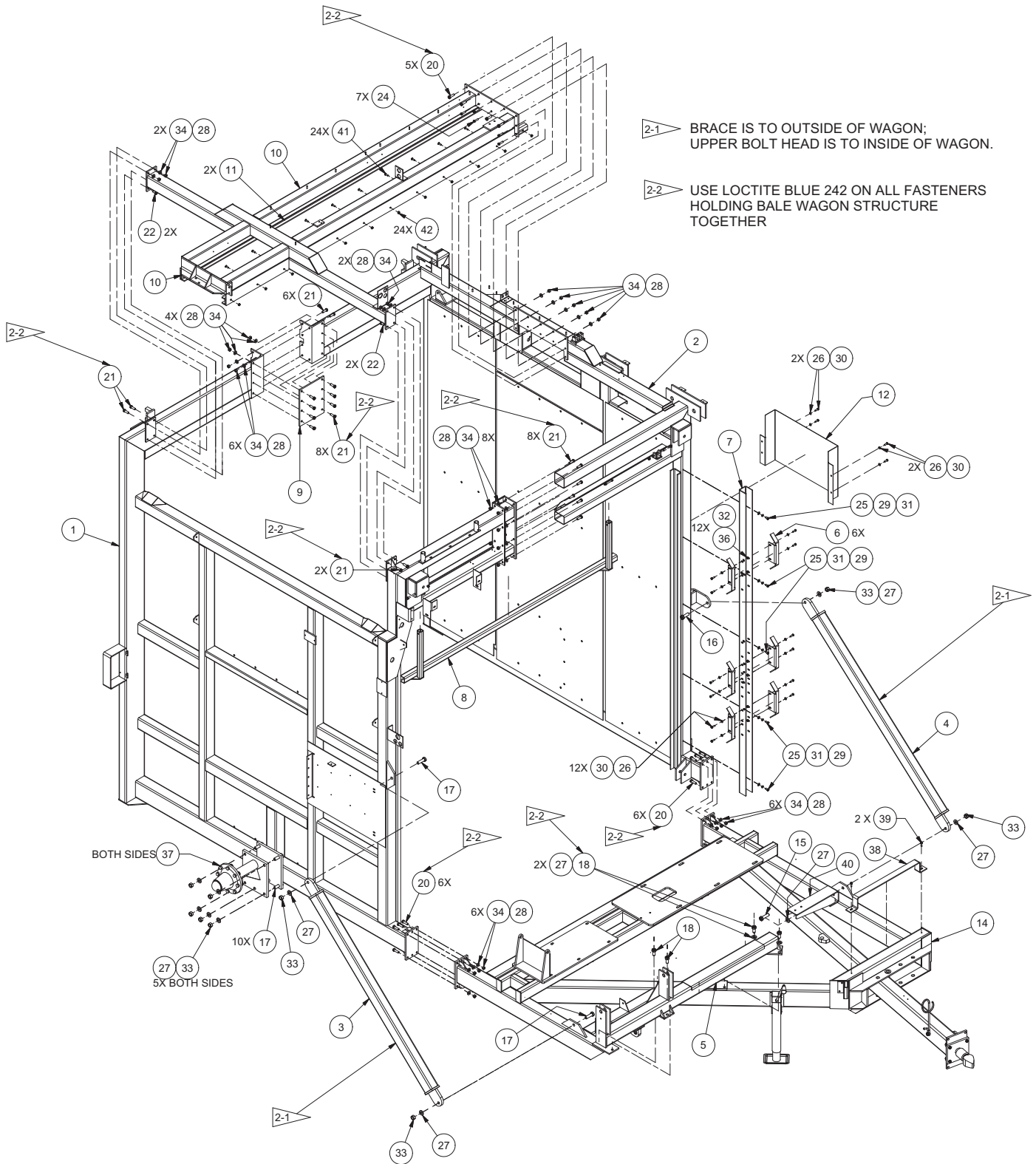

Frame Assembly

Page 2 of 2

Item	Part No.	Qty	Description	Item	Part No.	Qty	Description
	904891		Frame Assembly				
1	905008	1	. Frame, RH	24	Y17C-0624	7	. Capscrew
2	904837	1	. Frame, LH	25	162572W	5	. Capscrew
3	BRC7311601	1	. Brace, RH	26	R13811014	16	. Capscrew
4	BRC7311600	1	. Brace, LH	27	221777W	17	. Washer
5	ELV0073199	1	. Tube	28	221771W	39	. Washer
6	CAM0016742	6	. Plate, Cam	29	221767W	5	. Washer
7	DRW0016741	1	. Plate, Mounting	30	R13802914	16	. Washer
8	RET0073165	1	. Tie-Tier Retainer, Front	31	R13812514	5	. Lockwasher
9	PLT0073376	1	. Plate, Reinf	32	R13812513	12	. Lockwasher
10	FRM0016910	1	. Frame, Top Main	33	221716W	14	. Hex Nut
11	TRK0073201	2	. Plate, Roller Track	34	221711W	39	. Hex Nut
12	GRD0032406	1	. Plate, Guard	36	221705W	12	. Hex Nut
14	* 904986	1	. Hitch Assembly (Page 11)	37	* 21-901	2	. Hub Group, Complete (Page 15)
15	221659W	1	. Capscrew	38	905107	1	. Bar, Mounting
16	Y17C-1236	1	. Capscrew	39	SMS0000177	2	. Bolt, Whiz
17	221657W	12	. Capscrew	40	906543	1	. Support
18	169337W	4	. Capscrew	41	Y09G-0516	24	. Capscrew
20	221569W	17	. Capscrew	42	00273802	24	. Nut, Serrated
21	200454W	26	. Capscrew	43	246037	1BTL	. Threadlock, Removable
22	221560W	4	. Capscrew				

* See Separate Page

Rev G

Hitch Assembly

Page 1 of 2

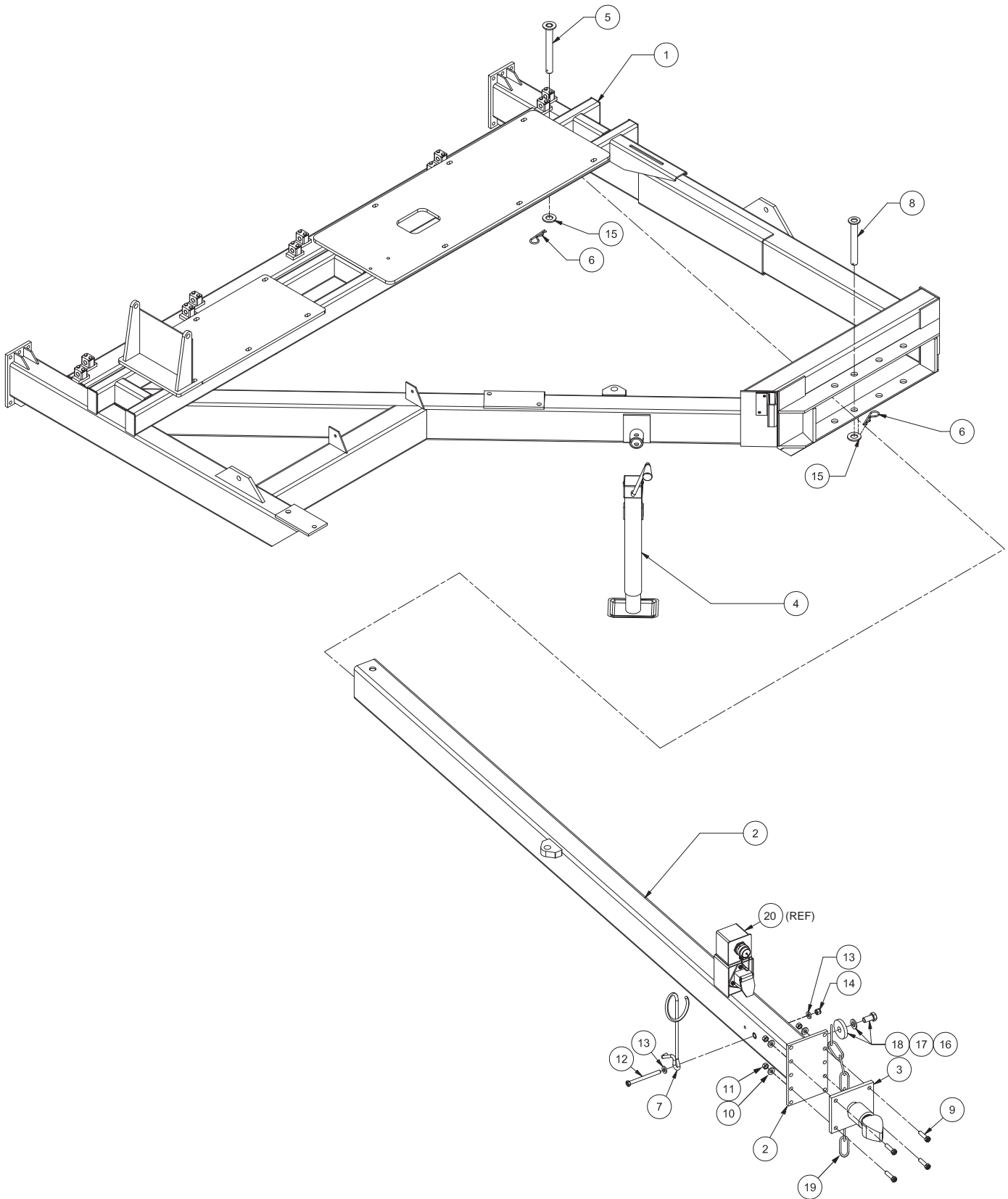

Hitch Assembly

Page 2 of 2

Item	Part No.	Qty	Description	Item	Part No.	Qty	Description
	904986		Hitch Assembly				
1	904985	1	. Hitch	11	221711W	4	. Hex Nut
2	DRB0025843	1	. Drawbar	12	18598W	1	. Capscrew
3	HTH0032715	1	. Ball Hitch	13	R13811433	2	. Hard Washer
4	JCK0178203	1	. Jack	14	R13811193	1	. Locknut
5	PIN0073343	1	. Pin	15	221780W	2	. Washer
6	F000006511	2	. Cotter Pin	16	905240	1	. Spacer
7	HGR0016785	1	. Hydraulic Hose Hanger	17	221777W	1	. Washer
8	PIN0073342	1	. Pin	18	169337W	1	. Capscrew
9	R13811077	4	. Capscrew	19	CHN0001390	1	. Chain, Ag Safety
10	221771W	4	. Washer	20	* 905065	Ref	Drawbar Receptical Box (Page 13)

* See Separate Page

Rev C

Drawbar Receptacle Installation

Page 1 of 2

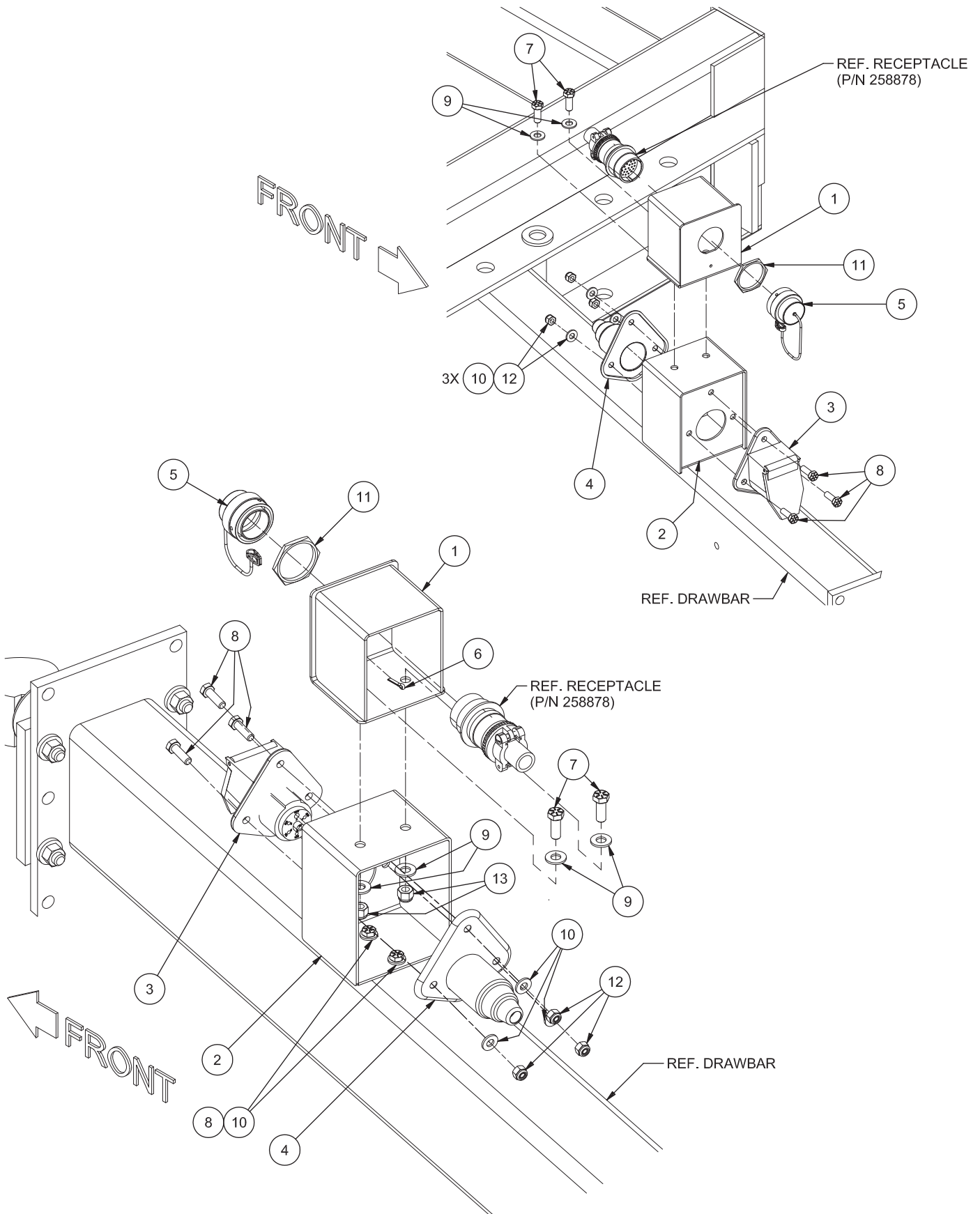

Drawbar Receptacle Installation

Page 2 of 2

Item	Part No.	Qty	Description	Item	Part No.	Qty	Description
	905065		Box Assembly				
1	905068	1	. Box Weldment	8	R13811014	5	. Capscrew
2	905069	1	. Bracket	9	221767W	4	. Washer
3	SOK0012310	1	. Socket	10	R13802914	5	. Washer
4	SOK0000007	1	. Boot	11	R740836	1	. Nut
5	250591	1	. Cap, Dust	12	232939	3	. Nut, Esna
6	00103385	1	. Cotter Pin	13	237567	2	. Nut, Esna
7	Y17C-0616	2	. Capscrew				

Rev -

Wheel Installation

Page 1 of 2

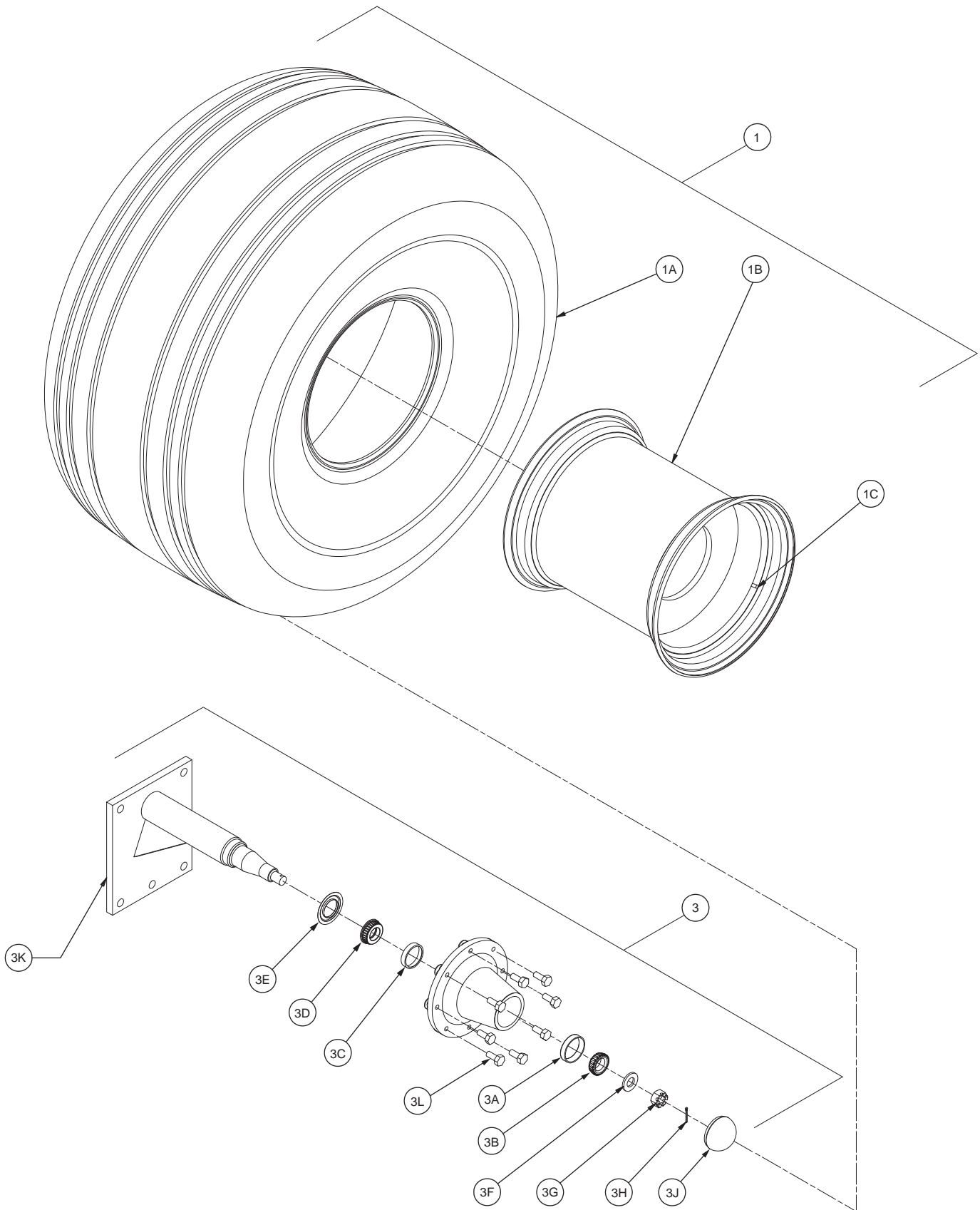

Wheel Installation

Page 2 of 2

Item	Part No.	Qty	Description	Item	Part No.	Qty	Description
	904900		Wheel Installation				
1	WHL0053579	1	. Tire & Wheel Assy	3D	F000000323	1	.. Inner Bearing Cone
1A	TIR2151614	1	.. Flotation Tire	3E	02-122	1	.. Grease Seal
1B	WHL 1 8493	1	.. Wheel	3F	21-179	1	.. Spindle Washer
1C	19-109	1	. Valve Stem	3G	NFC0008750	1	.. Castle Nut
3	* - - - - -	REF	. Hub Group, Complete (Page 9)	3H	COT0000503	1	.. Cotter Pin
3A	02-125	1	.. Bearing Cup, Outer	3J	F000008000	1	.. Cap, Hub
3B	02-126	1	.. Outer Bearing Cone	3K	SPN0032649	1	.. Spindle
3C	230351W	1	.. Bearing Cup, Inner	3L	21-108	8	.. Lug Bolt

* See Separate Page For Complete Spindle & Hub Assembly

Rev D

Pickup Installation

Page 1 of 2

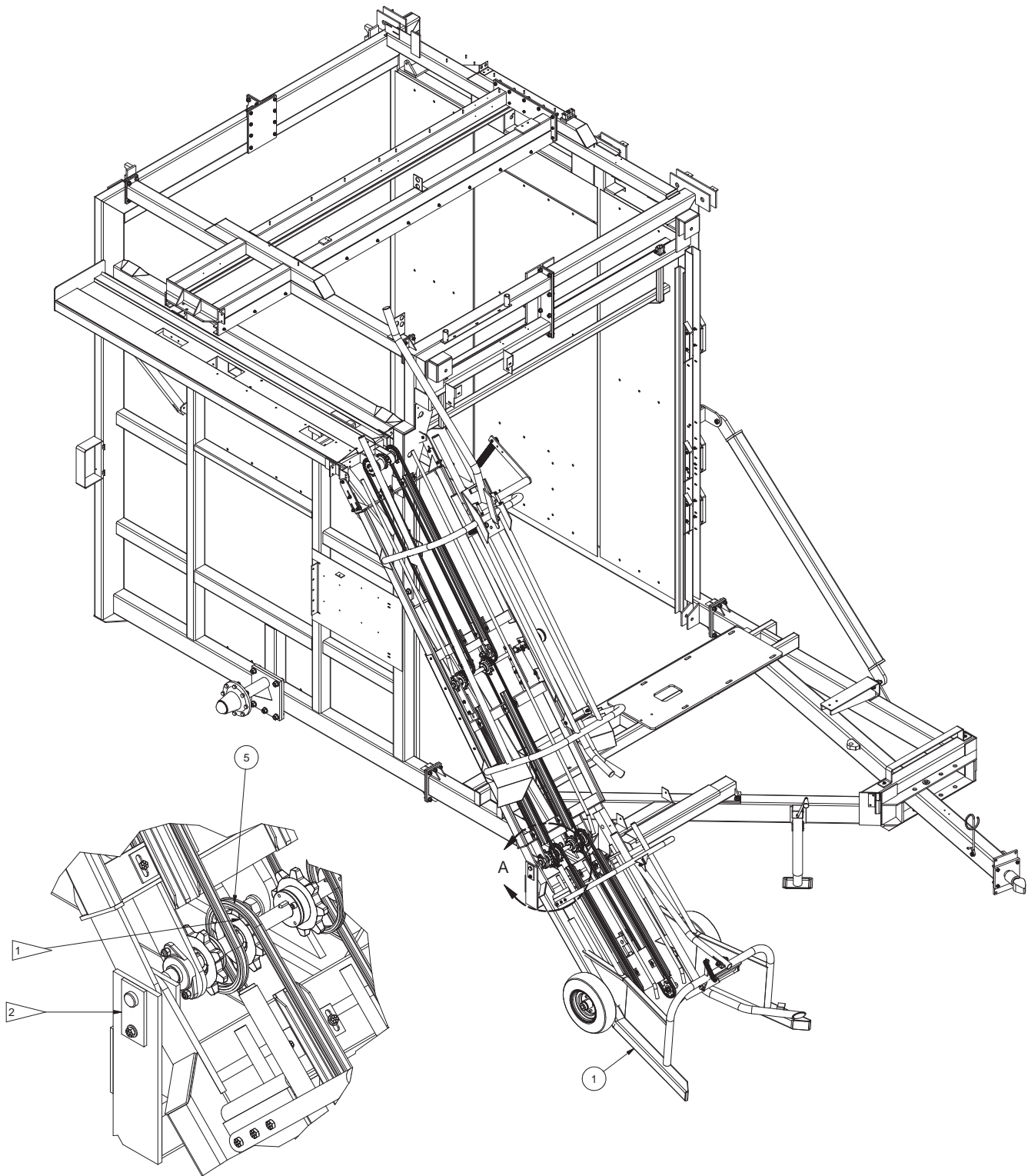

DETAIL A 2 PLACES

NOTES:

- 1 - REFERENCE SPROCKET P/N SPK0025111 (SEE ELEVATOR INSTALLATION 904902).
- 2 - REFERENCE PIN P/N PIN0026531 (SEE ELEVATOR INSTALLATION 904902).
CONNECTION BETWEEN PICKUP & ELEVATOR ASSEMBLY

Pickup Installation

Page 2 of 2

Item	Part No.	Qty	Description	Item	Part No.	Qty	Description
	904901		Pickup Installation				
1	* 902442	1	. Pickup Assembly (Page 19)				
5	CHN0032748	2	. Pickup Chain				

* See Separate Page

Rev B

Pickup Assembly

Page 1 of 4

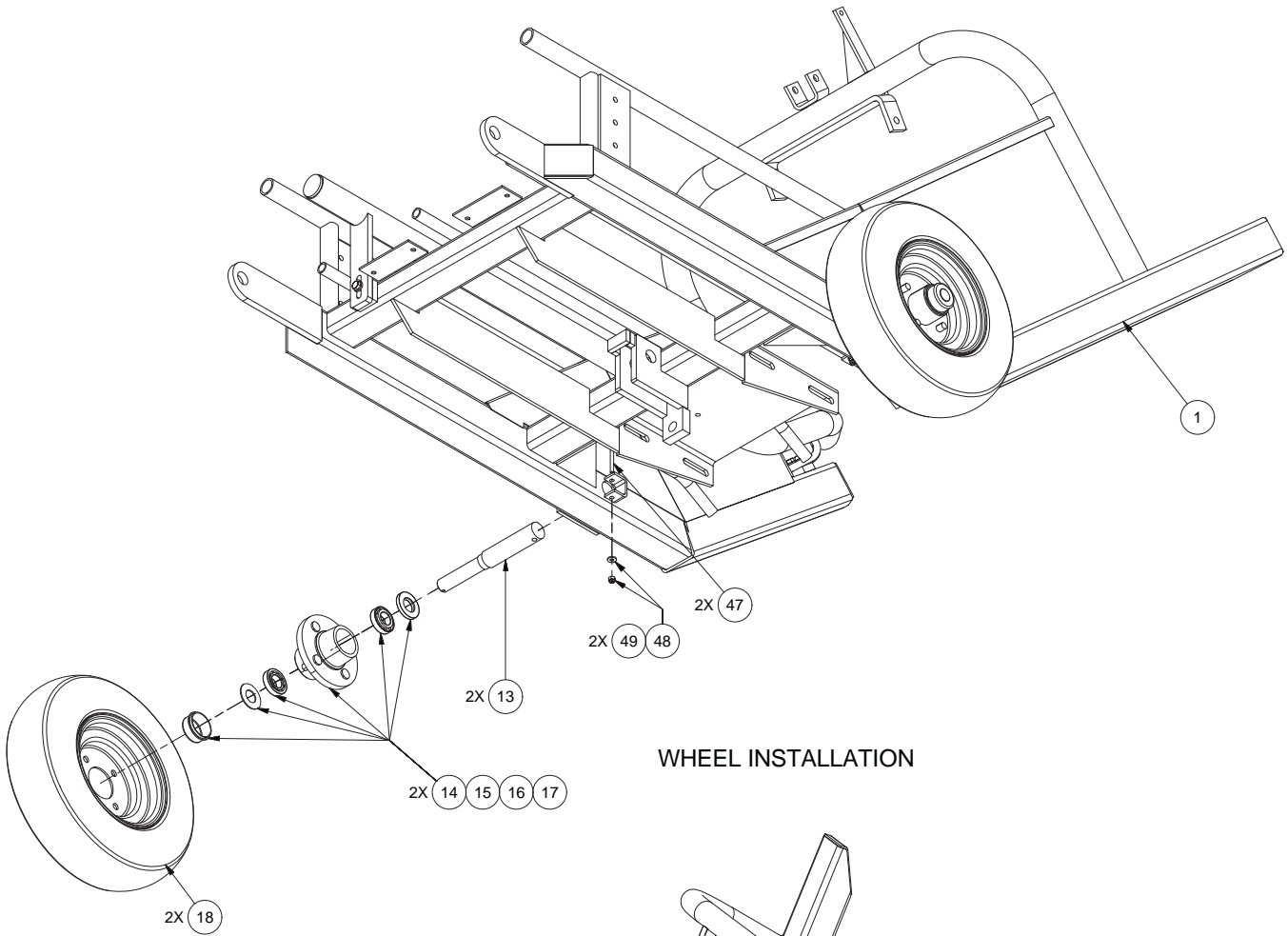

WHEEL INSTALLATION

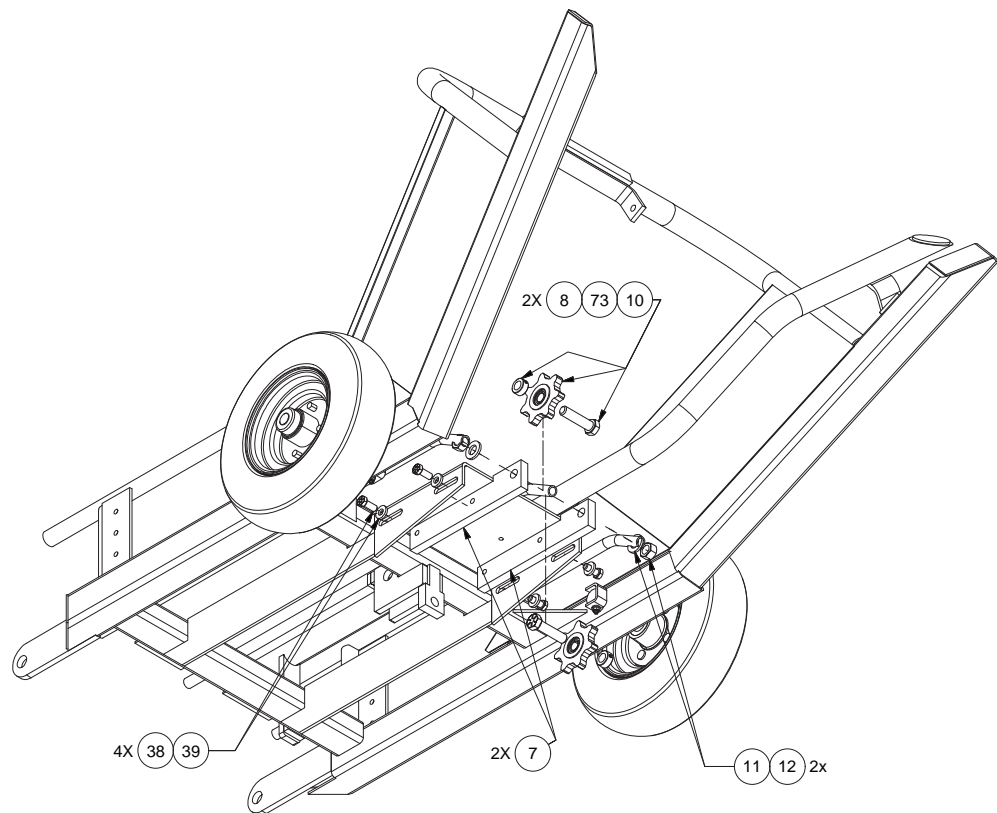

SPROCKET INSTALLATION

Pickup Assembly

Page 2 of 4

Item	Part No.	Qty	Description	Item	Part No.	Qty	Description
902442 Pickup Assembly							
1	PCY0032354	1	. Frame, Pickup	36	R13811014	6	. Capscrew
2	SUP0032395	1	. Pickup Bale Guide Support	37	232939	6	. Nut, Esna
3	DRW0073259	1	. Holddown Bar	38	221771W	6	. Washer
4	10-145	1	. Pin	39	221563W	4	. Capscrew
5	F000000747	1	. Square Tip Rod Return Spring	40	221767W	8	. Washer
6	10-144	1	. Bale Check	41	R13811083	1	. Capscrew
7	MNT0032340	2	. Plate, Sprocket	42	00103409	1	. Cotter Pin
8	F000000172	2	. Set Collar	43	R13811191	7	. Locknut
9	SPK0008039	2	. Sprocket	44	R13801813	1	. Capscrew
10	177192W	2	. Capscrew	45	R13811193	1	. Locknut
11	R13802633	2	. Flat Washer	46	R13811040	6	. Capscrew
12	221716W	2	. Hex Nut	47	R13810998	2	. Capscrew
13	SPN0025350	2	. Pickup Wheel Spindle	48	221763W	2	. Washer
14	HUB0000348	2	. Hub Assembly	49	R13811189	2	. Locknut
18	WHL0401530	2	. Wheel & Tire Assembly	50	R13802621	4	. Flat Washer
32	TRK0032325	1	. R.H. Pick-Up Chain Track	51	R13811512	4	. Hex Nut
33	TRK0032322	1	. L.H. Pick-Up Chain Track	52	18498W	2	. Capscrew
34	BAR0031491	1	. Crowder Bar, Lower	53	174413W	3	. Screw
35	R13802914	12	. Hard Washer				

Rev B

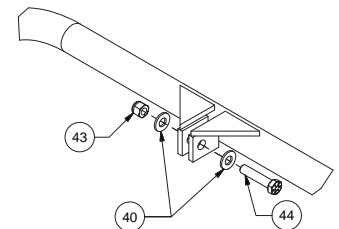
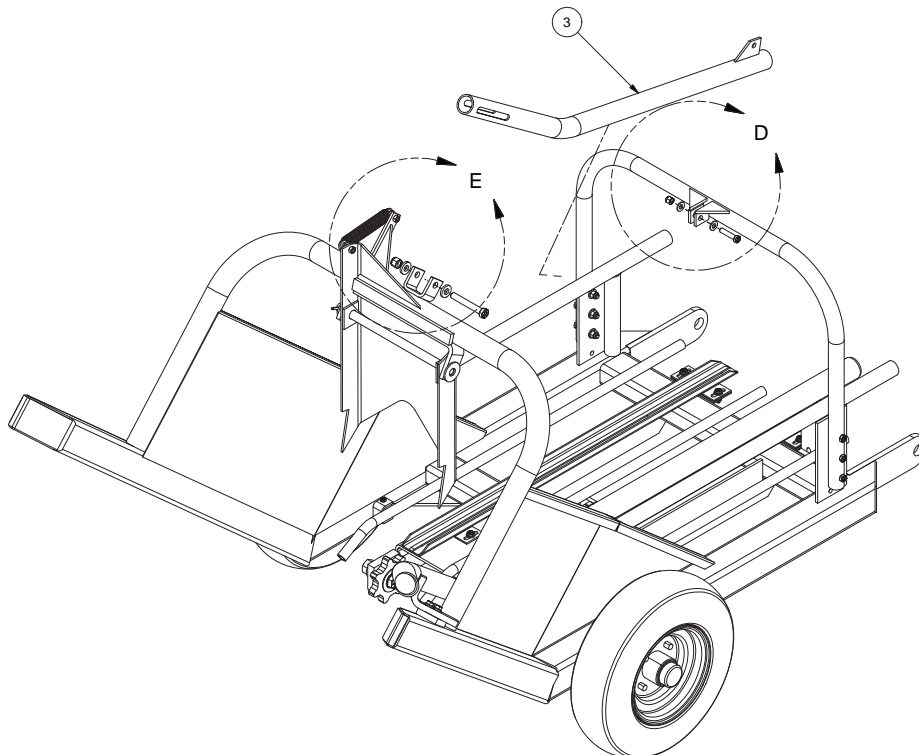

DETAIL D

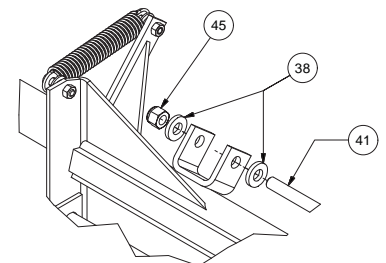

DETAIL E

BALE HOLDDOWN BAR INSTALLATION

Pickup Assembly

Page 3 of 4

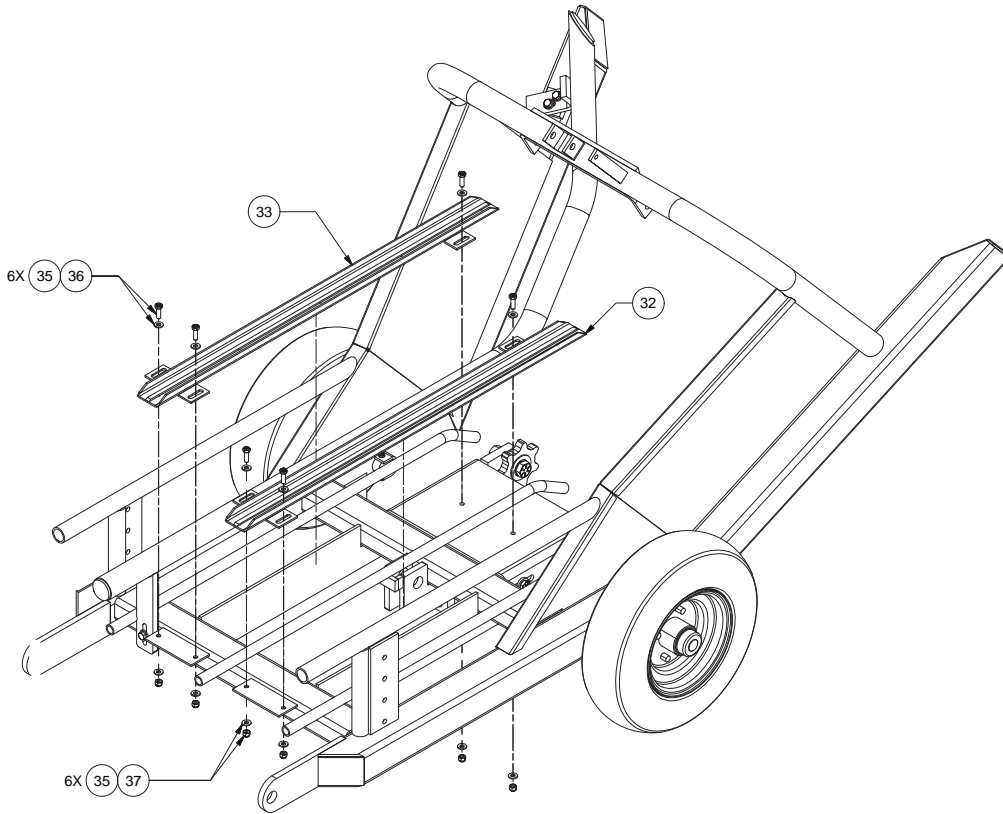

CHAIN TRACK INSTALLATION

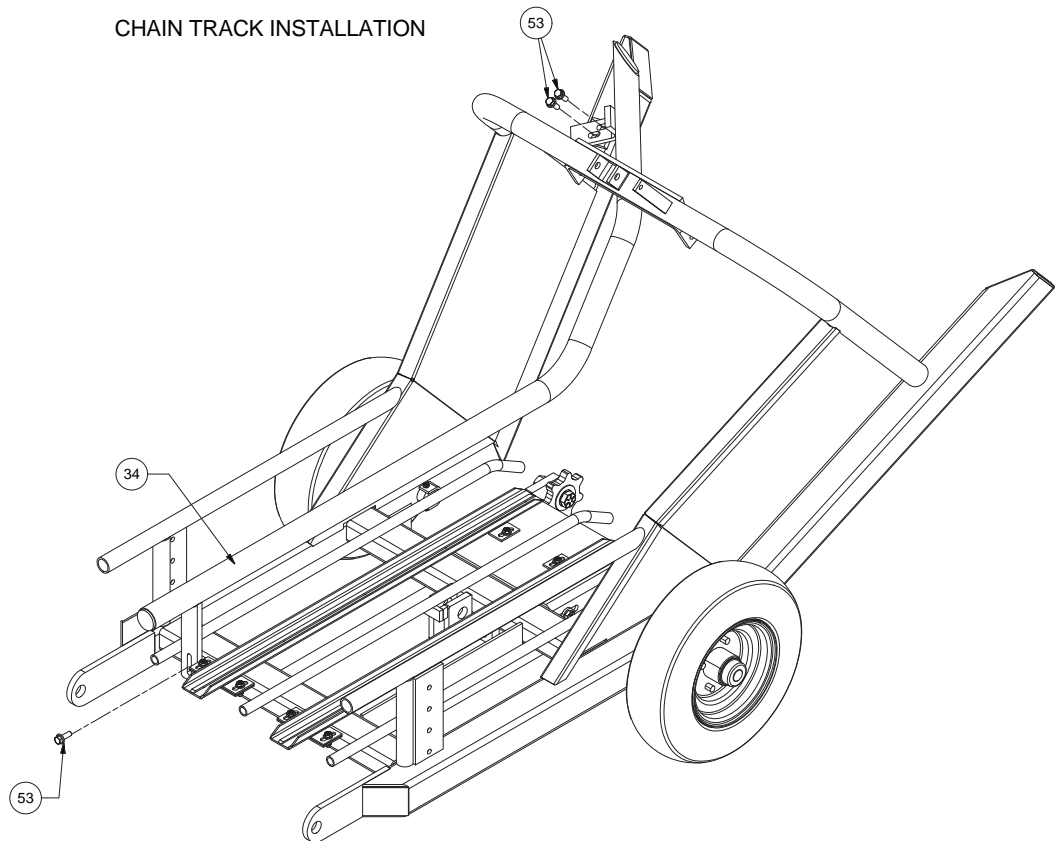

CROWDER BAR INSTALLATION

Pickup Assembly

Page 4 of 4

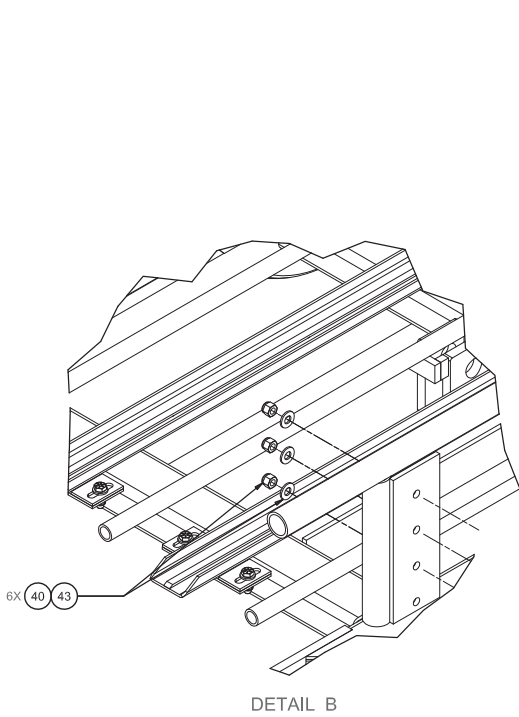

DETAIL B

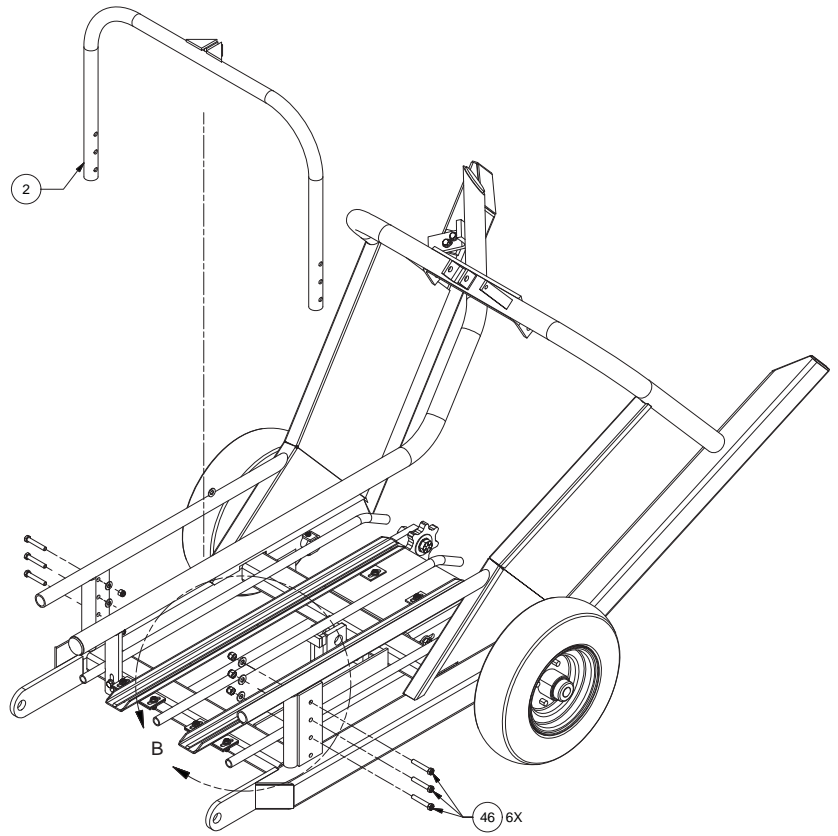

BALE GUIDE INSTALLATION

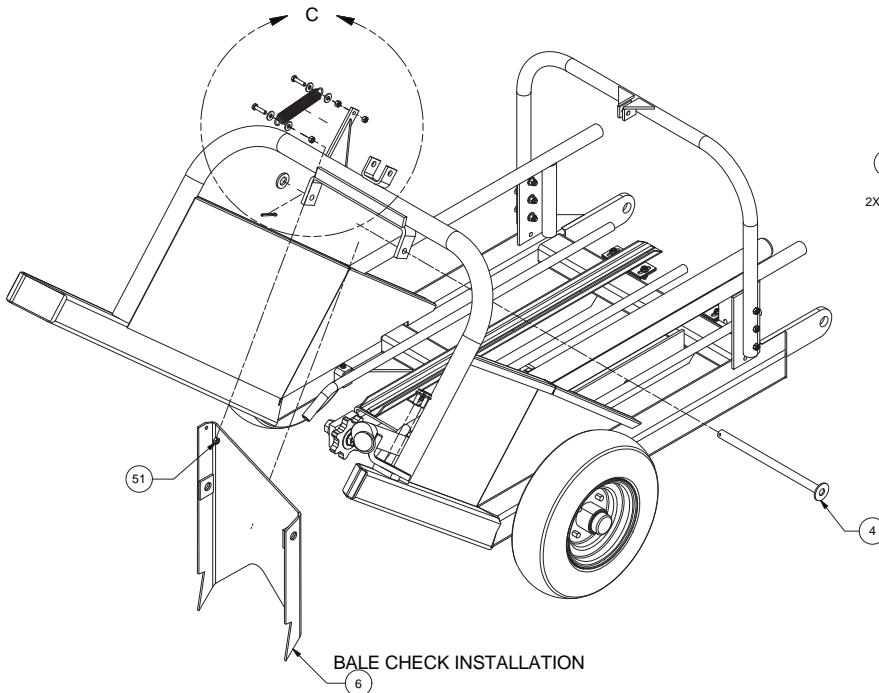

BALE CHECK INSTALLATION

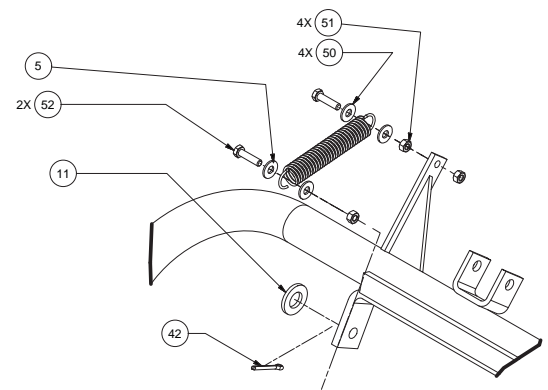

DETAIL C

Elevator Installation

Page 1 of 4

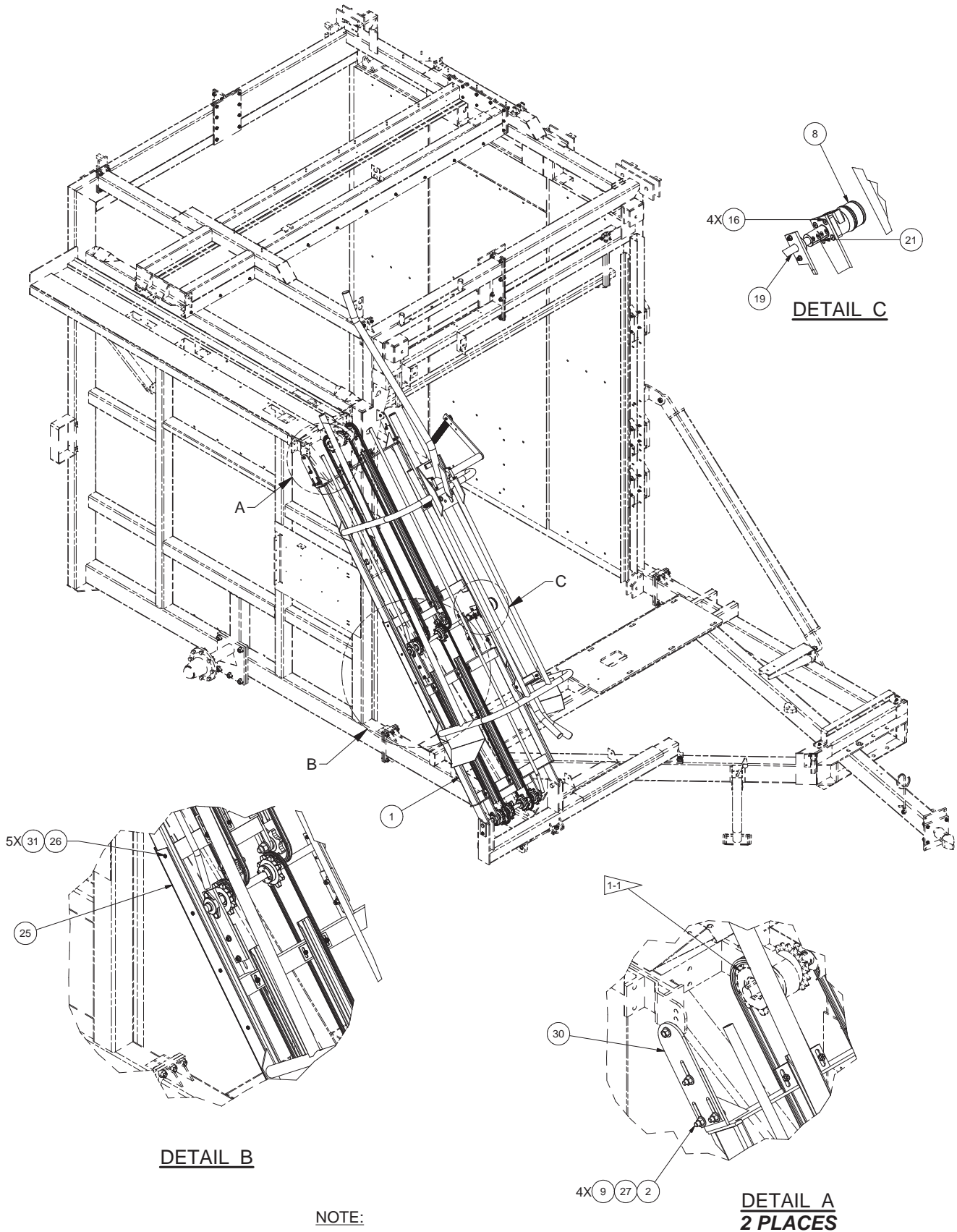

Elevator Installation

Page 2 of 4

Item	Part No.	Qty	Description	Item	Part No.	Qty	Description
	904902		Elevator Installation				
1	* 902443	1	. Elevator Assembly (Page 27)	16	Y09G-0616	4	. Capscrew
2	221499W	8	. Capscrew	17	Y17C-0624	8	. Capscrew
3	R13802914	8	. Hard Washer	18	R13811190	8	. Locknut
4	CHN0035051	2	. Chain	19	SHF0032650	1	. Shaft
6	CHN0035052	2	. Chain	20	SHF0032651	1	. Shaft
7	221716W	2	. Hex Nut	21	CPL0010011	1	. Coupling
8	MTR00RSAK1	1	. Motor, Hydraulic	22	SPK0008039	2	. Sprocket
9	221707W	8	. Hex Nut	23	48688	6	. Key
10	SPK0025111	6	. Sprocket	24	BSH0000H10	6	. Split Taper Bsh
11	02-104	4	. Flange Bearing	25	SHD0032903	1	. Plate, Shield
12	PIN0026531	2	. Pickup Pivot Pin	26	R13810996	5	. Capscrew
13	R13811034	2	. Capscrew	27	221767W	10	. Washer
14	177192W	2	. Capscrew	30	MNT0073145	2	. Elevator Upper Mount - Slotted
15	221777W	8	. Washer	31	235620	5	. Nut, Esna

* See Separate Page

Rev C

Elevator Installation

Page 3 of 4

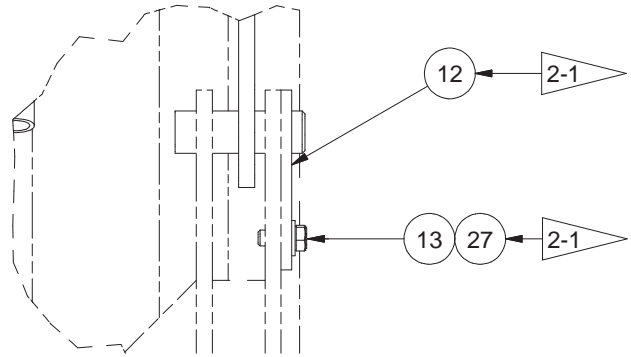
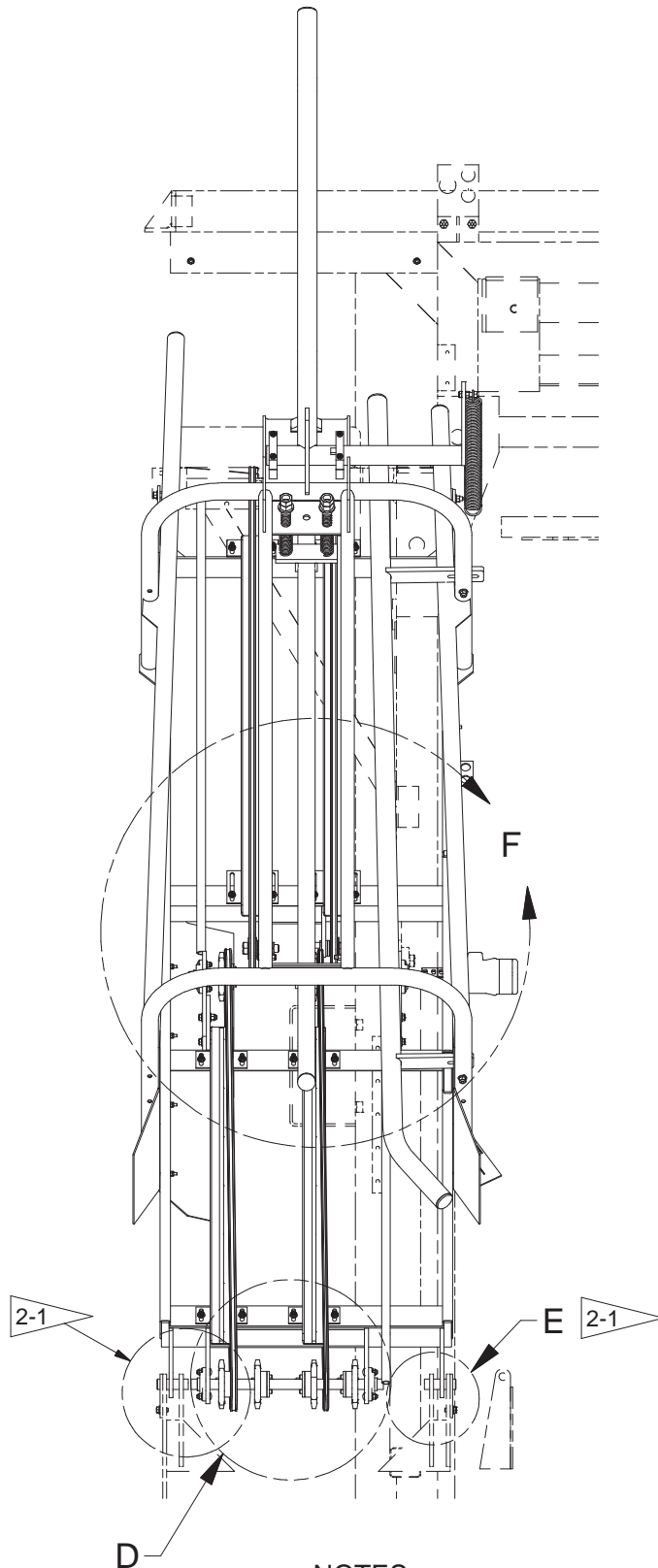

DETAIL E
2 PLACES

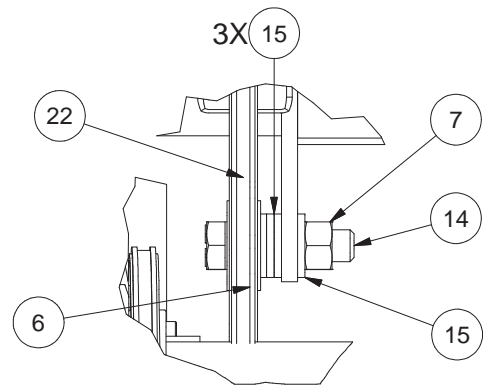

DETAIL G
2 PLACES

NOTES:

 - CONNECTION TO PICKUP ASSEMBLY (REFERENCE PICKUP INSTALLATION 904901).

Elevator Installation

Page 4 of 4

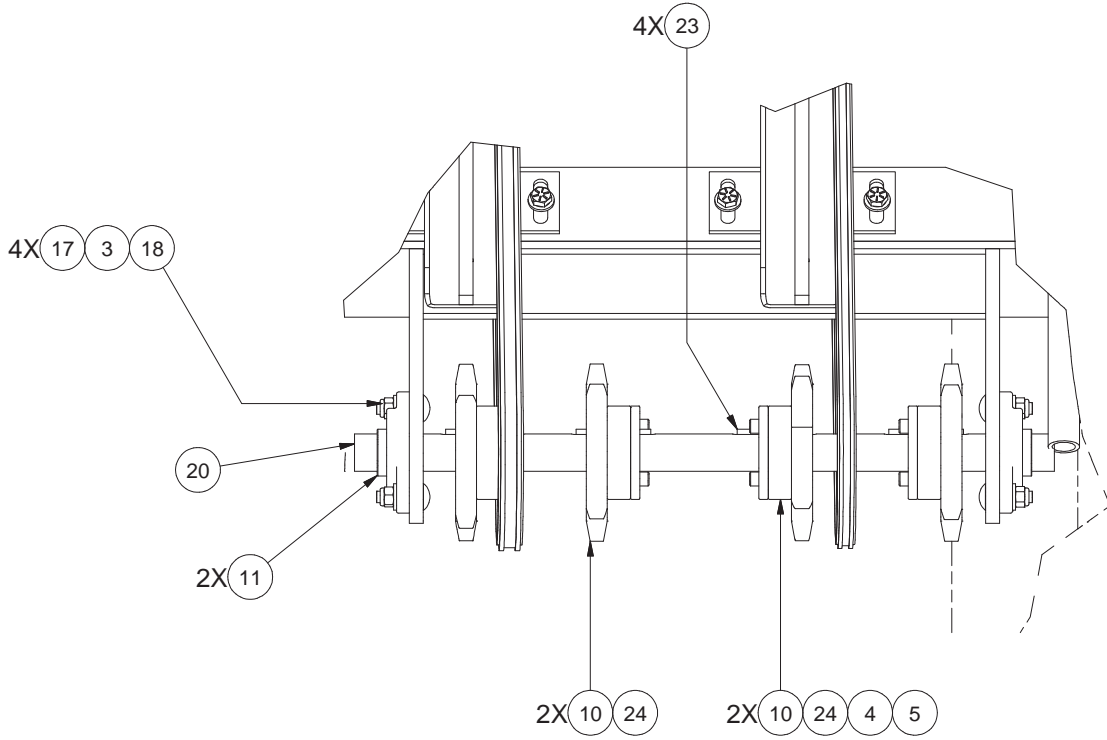

DETAIL D

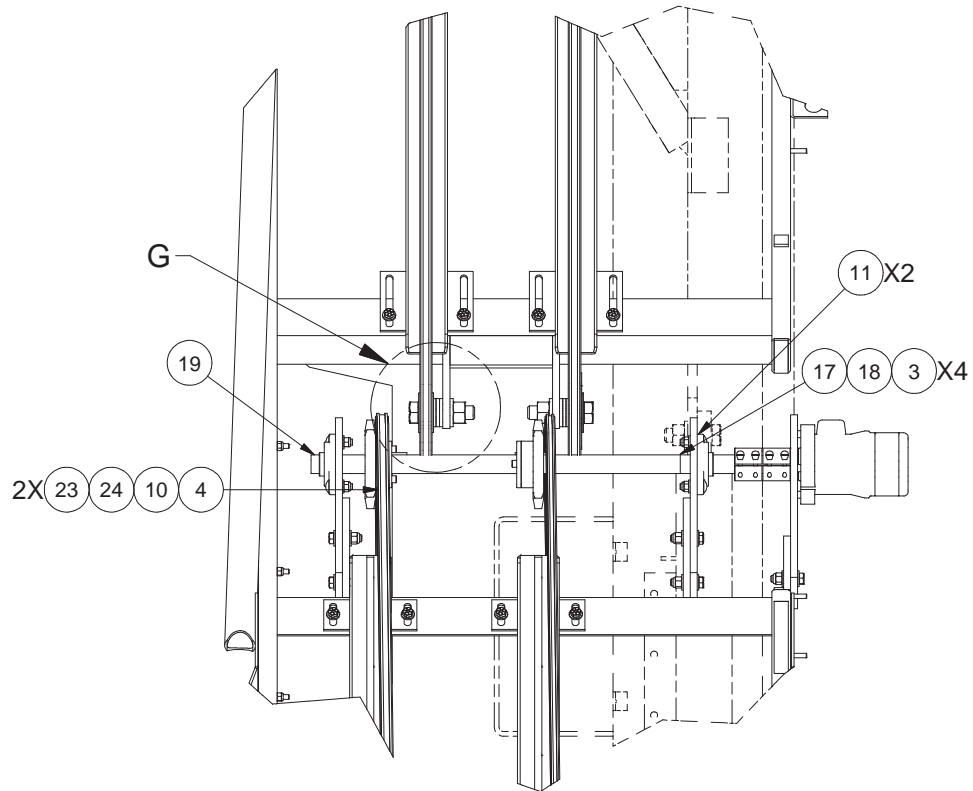

DETAIL F

Elevator Assembly

Page 1 of 4

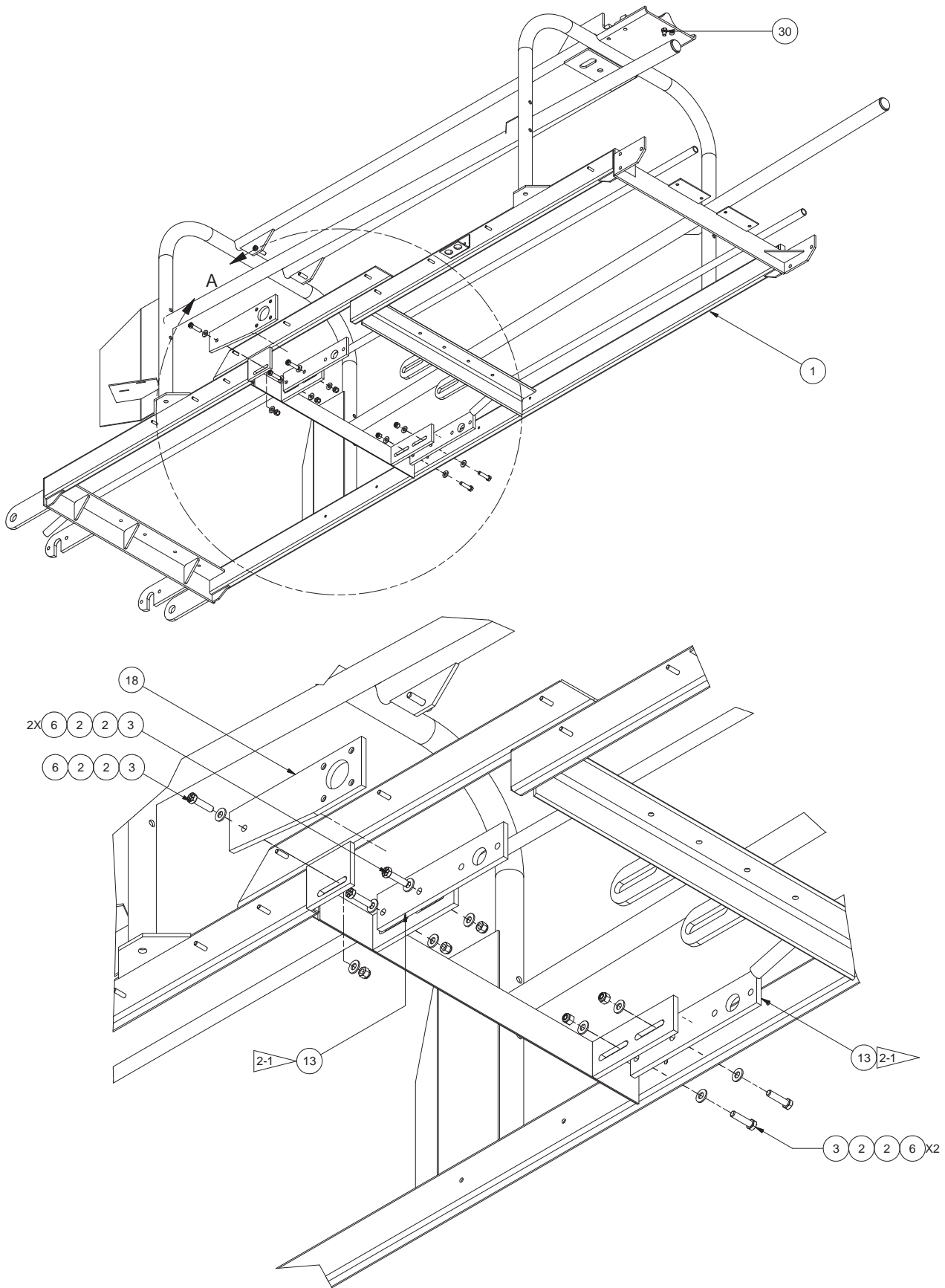

DETAIL A

Elevator Assembly

Page 2 of 4

Item	Part No.	Qty	Description	Item	Part No.	Qty	Description
902443 Elevator Assembly							
1	ELV0032327	1	. Frame, Elev	16	232939	20	. Nut, Esna
2	221767W	18	. Washer	17	221777W	4	. Washer
3	Y17C-0624	8	. Capscrew	18	MNT0032745	1	. Mount, Elevator Motor
4	TRK0032652	2	. Track, Lower Elevator Chain	22	BAR0073142	1	. Lower Hold Down Bar
5	TRK0032653	2	. Track	23	SPG0073238	2	. Spring
6	R13811191	9	. Locknut	24	BAR0031490	1	. Crowder Bar, Upper
8	221716W	4	. Hex Nut	25	ELV0073299	1	. Hold Down Arm, Elevator
9	R13811043	2	. Capscrew	26	R13806527	4	. Capscrew
11	221707W	2	. Hex Nut	27	MNT0073135	2	. Pipe Bushing Mounts
13	MNT0032737	2	. Bar, Mounting	28	SPG0017227	1	. Spring, Knockdown
14	R13811014	16	. Capscrew	29	F000008264	1	. Bumper, Rubber
15	R13802914	36	. Washer	30	224118	1	. Nut, Esna

Rev D

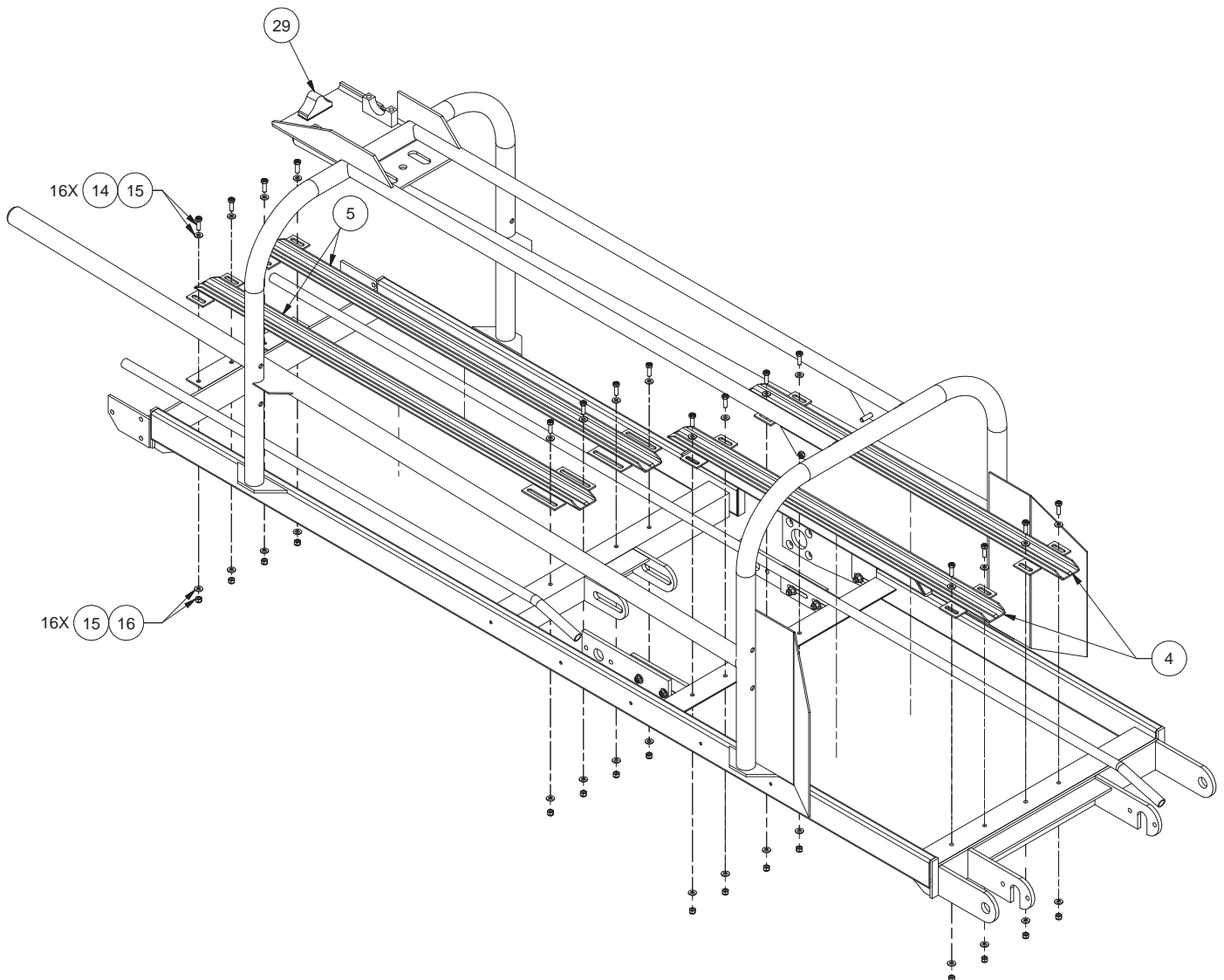

Elevator Assembly

Page 3 of 4

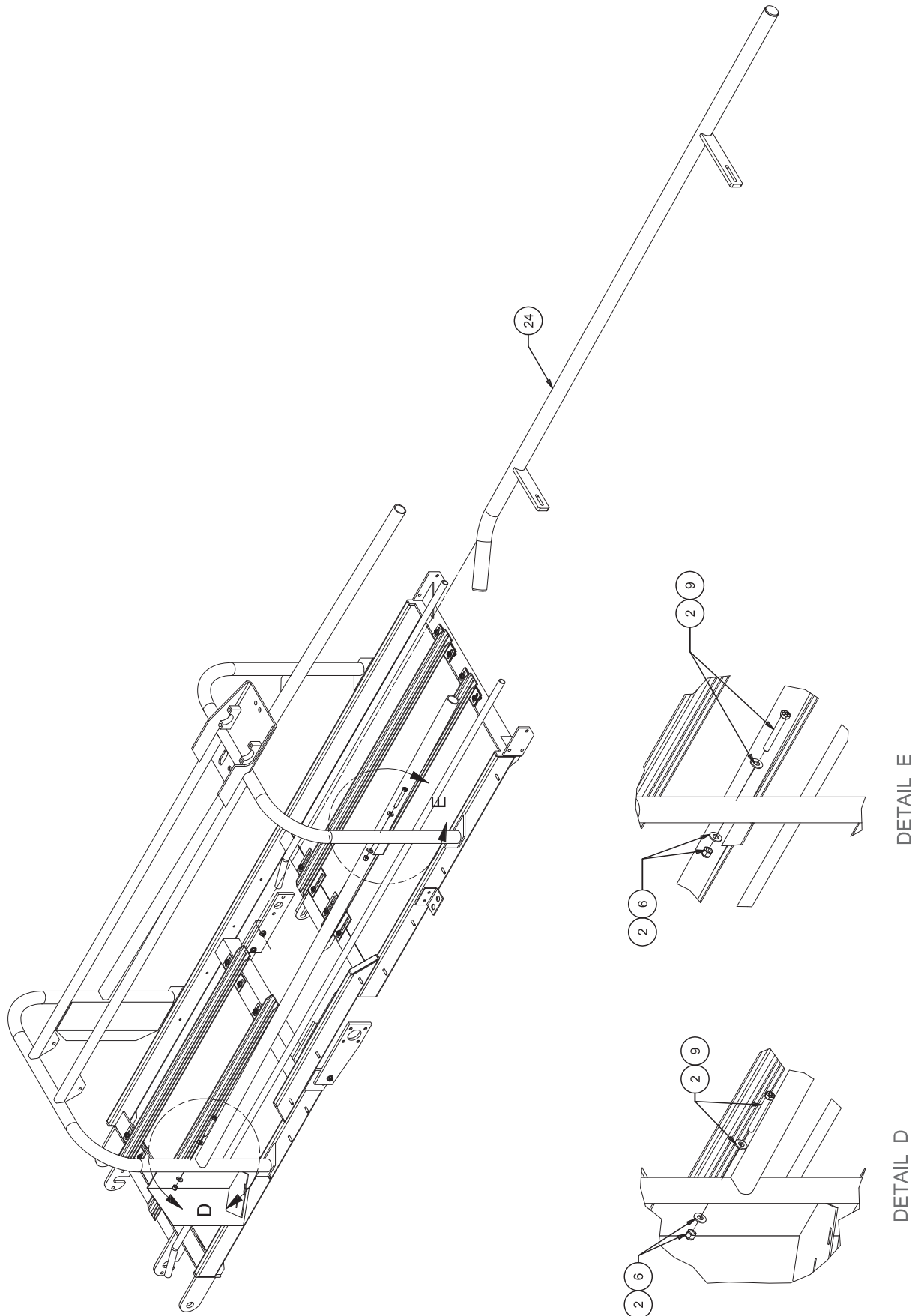

Elevator Assembly

Page 4 of 4

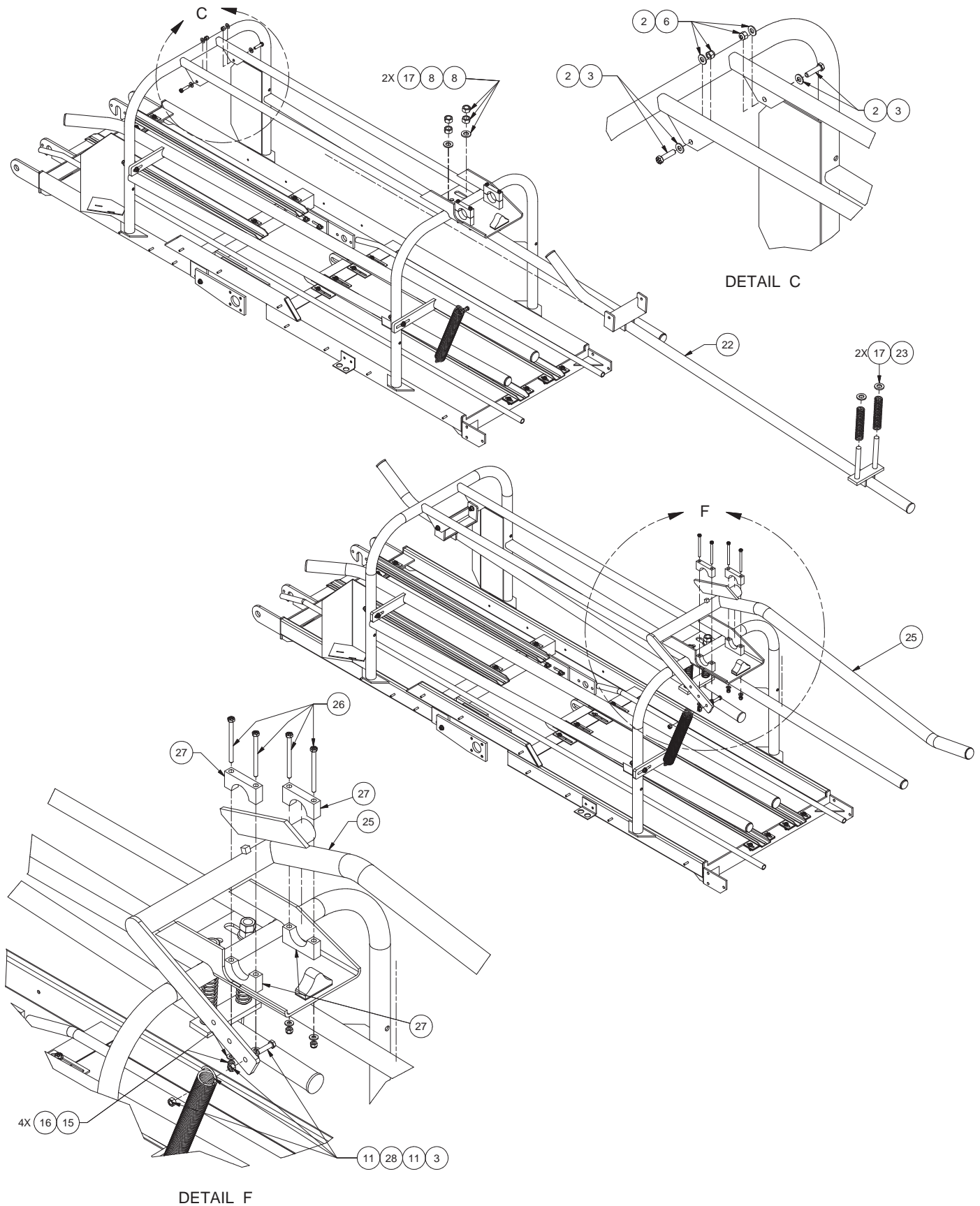

Load Bed Installation

Page 1 of 11

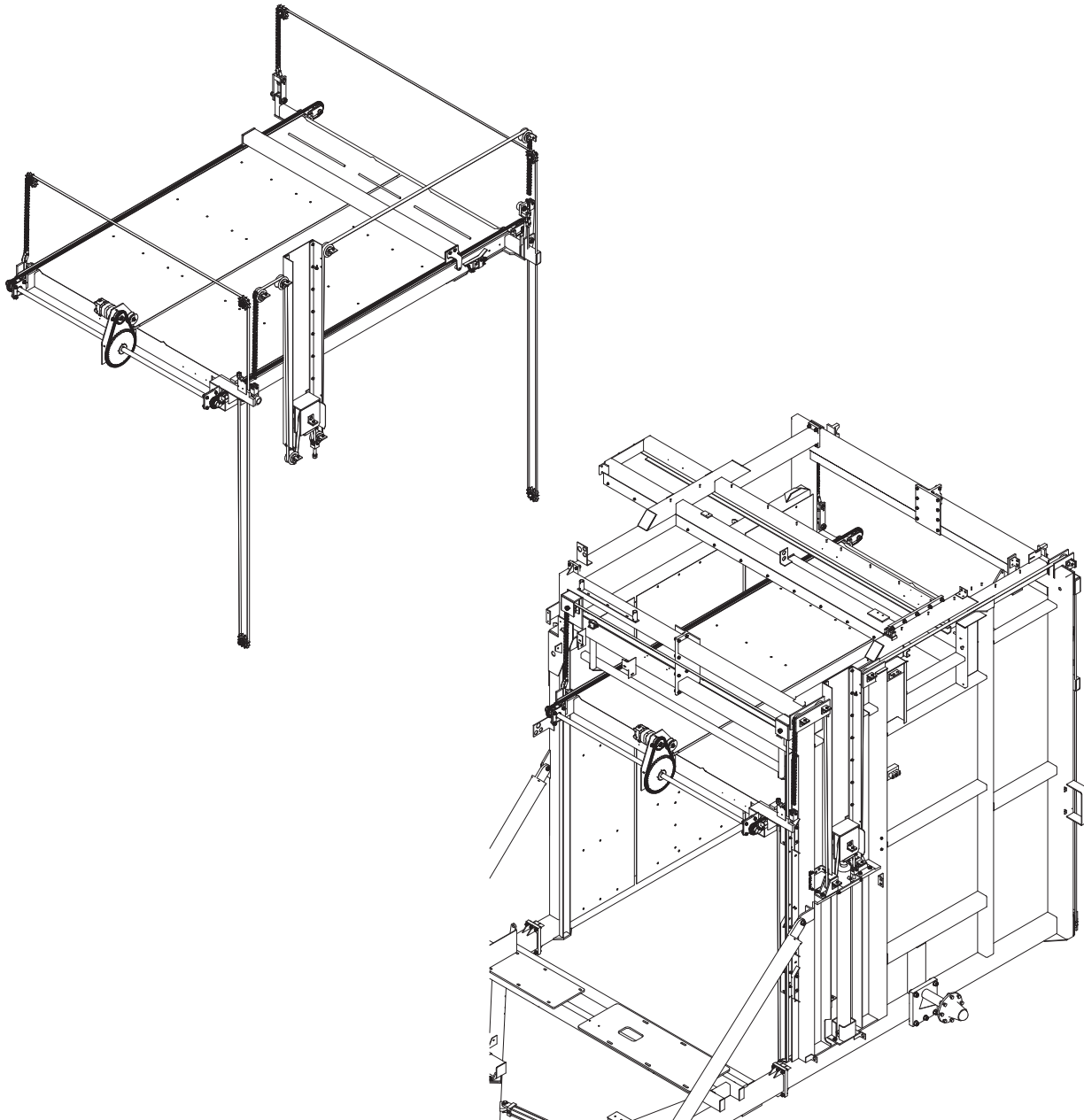

NOTES:

- 1-1) ORIENT ALL CHAIN CONNECTING LINK PIN LINKS SO THEY ARE FACING TO THE OUTSIDE OF THE MACHINE
- 1-2) INSTALL FRONT LOAD BED ROLLERS WITH (3) SHIMS (SHM0013233) EACH SIDE, LEAVING MOUNTS FINGER TIGHT FOR ADJUSTMENT.
- 1-3) CHECK THAT FRONT AND REAR CROSSOVER CHAIN DISTANCE TO FRAME IS CONSISTENT WITHIN 0.13". ALIGN LIFT CHAIN ROLLERS WITH CYLINDER HEAD ASSY (ITEM 55).
- 1-4) RAISE AND LOWER BED THROUGH ENTIRE DISTANCE OF TRAVEL, WATCHING THAT CHAINS DO NOT CLIMB OR BIND ON SPROCKETS.
- 1-5) NOTE ROLLER TO TRACK SIDE CLEARANCE FOR RANGE OF TRAVEL. ADD SHIMS (SHM0073233) TO ROLLER MOUNTS TO MAINTAIN MINIMUM 0.125" CLEARANCE BETWEEN ROLLER FACE AND TRACK AT TIGHTEST SPOT OF TRAVEL.
- 1-6) ADJUST ROLLER MOUNTS SO ROLLERS MATE WITH REAR OF TRACK, AND TORQUE TIGHT.

Load Bed Installation

Page 2 of 11

Item	Part No.	Qty	Description	Item	Part No.	Qty	Description
	904922		Load Bed Installation				
1	* 904863	1	. Limit Switch Instl, Push Off (Page 43)	46	BKT0073296	1	. Bracket, LH
3	177192W	7	. Capscrew	48	PIN0016952	1	. Capscrew
4	CHN0035045	2	. Chain	49	CHN0073055	2	. Tightener, Bed Chain
5	200608	8	. Washer	50	CHN0035048	1	. Chain
6	CHN0073024	4	. Pivot Mount F/Lift Chain	51	CHN0073228	1	. Swivel, Chain
7	SHM0073233	5	. Shim	54	PLT0073227	2	. Bar, LH Rear
8	MNT0035151	2	. Bed Roller Mount	55	* 904948	1	. Cylinder Head Assembly
9	BRG0001636	3	. Top Roller Bearing	56	BAR0073288	2	. Bar, Guide
10	PIN0016958	1	. Capscrew	57	CNK0002008	2	. Link, Connecting (Page 41)
11	05-214	2	. Sprocket	58	221707W	2	. Hex Nut
12	BRGRCJ1375	3	. Flange Bearing	59	221499W	4	. Capscrew
14	SHF0073285	1	. Shaft	60	221767W	16	. Washer
15	07-123	2	. Anchor Bolt Assembly, Chain	61	180959W	4	. Capscrew
16	CHN0035046	1	. Chain	62	221569W	2	. Capscrew
17	SPK0060048	1	. Sprocket	63	R13811015	16	. Capscrew
18	SPK0073349	8	. Sprocket	64	R13811080	1	. Capscrew
19	221717W	6	. Hex Nut	65	221777W	5	. Washer
20	R13809570	5	. Jam Nut	66	237567	8	. Nut, Esna
21	F00000883	1	. Idler Pulley	67	232939	16	. Nut, Esna
22	MTR1041026	1	. Motor, Hydraulic	68	00103387	4	. Cotter Pin
23	SHD0016867	1	. Shield Weldment	69	BED0073275	1	. BedWasher
24	SPK0060154	1	. Sprocket	70	SQS5004000	4	. Set Screw
26	CHN0035047	1	. Chain	71	15011W	4	. Jam Nut
27	CHN0035050	1	. Chain	72	F000007904	3	. Key
30	02-115	12	. Roller Bearing F/Main Mast	73	GUD0073016	1	. Plate, Guide
31	14-107	6	. Roller, Chain	74	BAR0073287	2	. Bar, Guide
32	PIN0033525	6	. Bed Lift Roller Pins	75	CNK0002080	4	. Connecting Link
33	14-104	2	. Anchor Bolt, Mast Lift Chain	76	R13811039	2	. Capscrew
35	CHN0035049	1	. Chain	77	BAR0073345	1	. Push Off Bar
36	221716W	3	. Hex Nut	78	ZZ00000428	1	. Key
37	R13811014	6	. Capscrew	79	SMS0000305	3	. Bolt, Whiz
38	221705W	6	. Hex Nut	80	Y17C-0616	4	. Capscrew
39	R13802914	22	. Washer	81	CNK0000802	2	. Link, Connecting
40	221771W	22	. Washer	82	221664W	1	. Capscrew
41	221711W	15	. Hex Nut	83	F000000760	2	. Link, Connecting
42	200454W	16	. Capscrew	84	ZZ00000208	A/R	. Bushing
45	NCC0001000	2	. Castle Nut				

* See Separate Page

Rev F

Load Bed Installation

Page 3 of 11

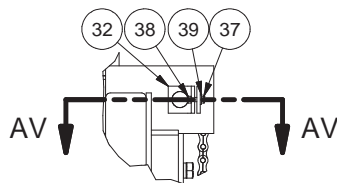
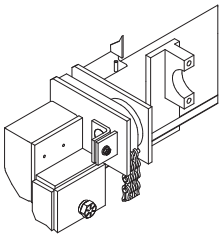
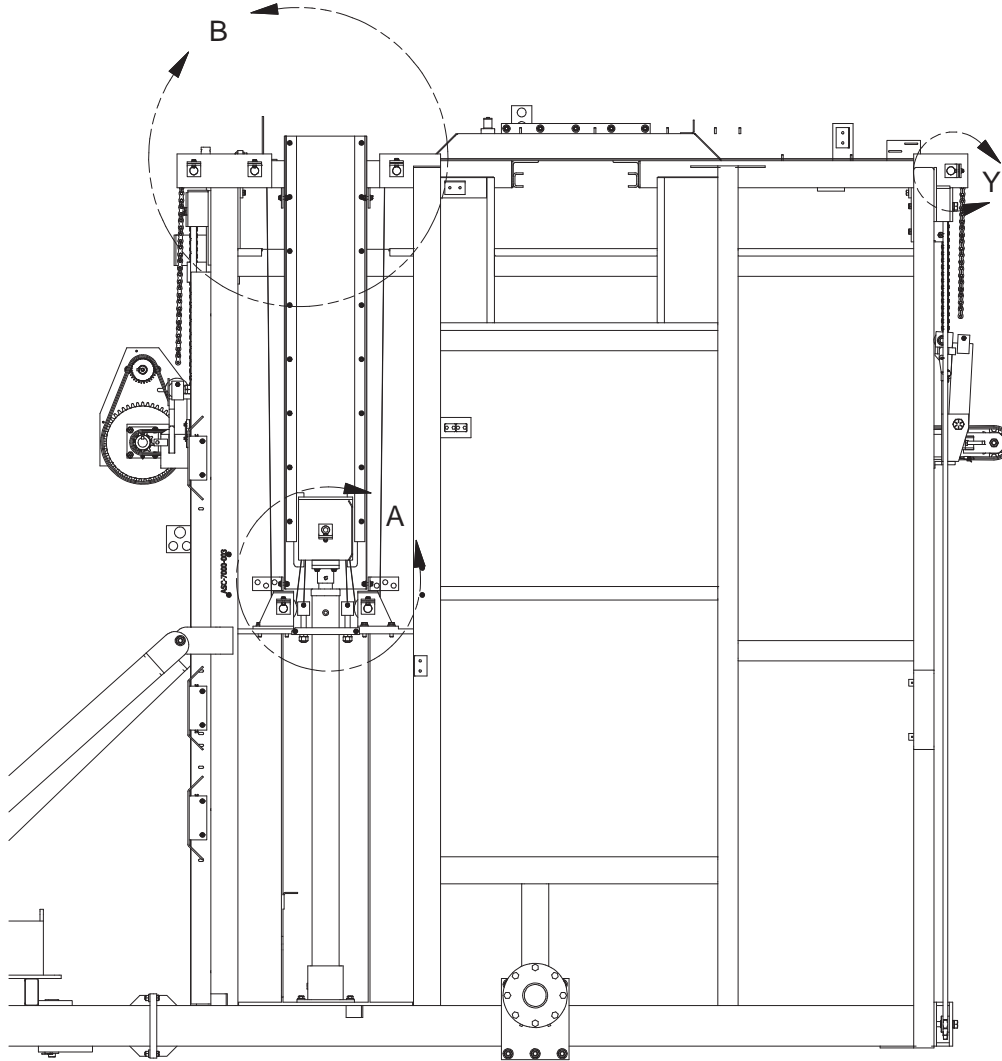

DETAIL Y

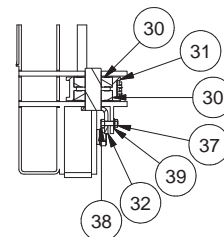

SECTION AV-AV

- NOTES:
- 2-1 LEAVE AT LEAST THREE THREADS PAST NUT/JAM NUT. TORQUE NUT TO 270 FT-LBS ONTO JAM NUT.
 - 2-2 LEVEL THE LOAD BED TO WITHIN A DIFFERENCE OF NO MORE THAN 0.8" ACROSS THE LENGTH OF THE LOAD BED FROM THE FRONT OF THE LOAD BED TO THE BACK OF THE LOAD BED AND FROM THE LH SIDE OF THE LOAD BED TO THE RH SIDE OF THE LOAD BED. USE THE ADJUSTING BOLTS TO ACHIEVE THIS. THERE MUST BE AT LEAST THREE (3) THREADS PROTRUDING PAST THE NUT WHEN THE FINAL ADJUSTMENT IS ACHIEVED.

Load Bed Installation

Page 4 of 11

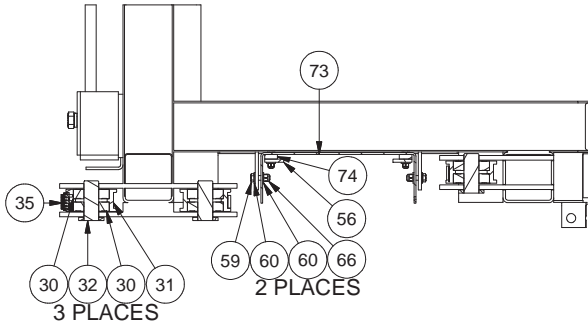

SECTION J-J

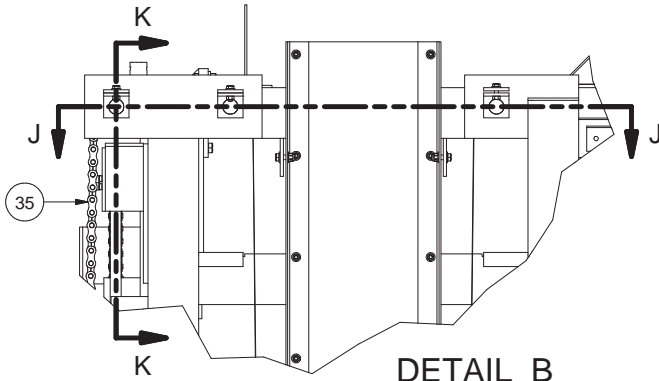
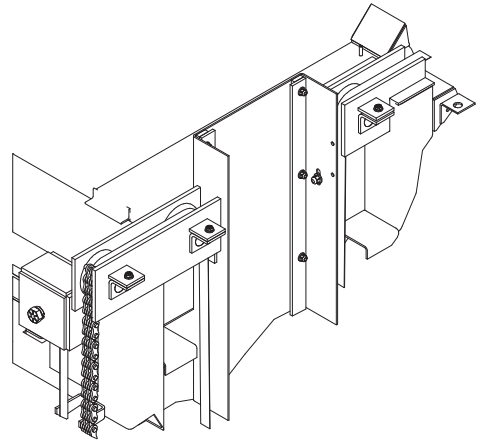

DETAIL B

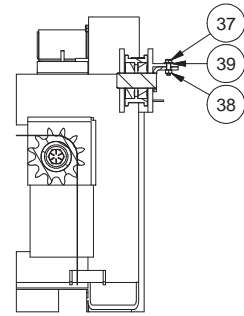

**SECTION K-K
3 PLACES**

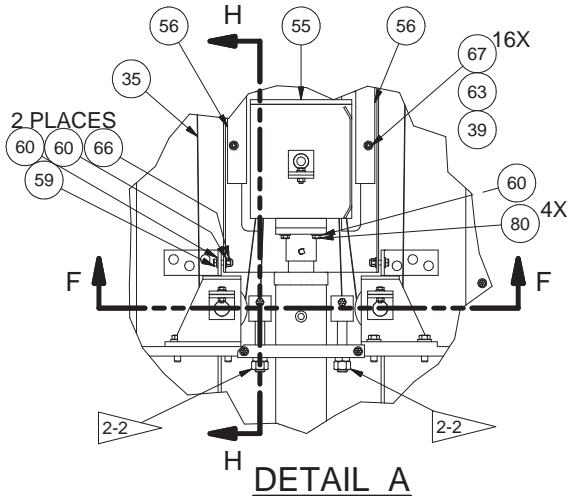

DETAIL A

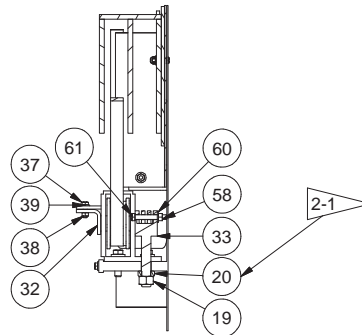

**SECTION H-H
2 PLACES**

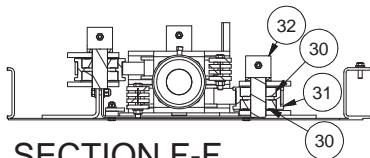

**SECTION F-F
3 PLACES**

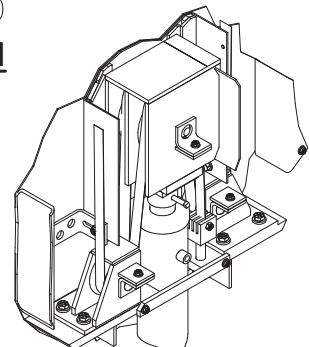

Load Bed Installation

Page 5 of 11

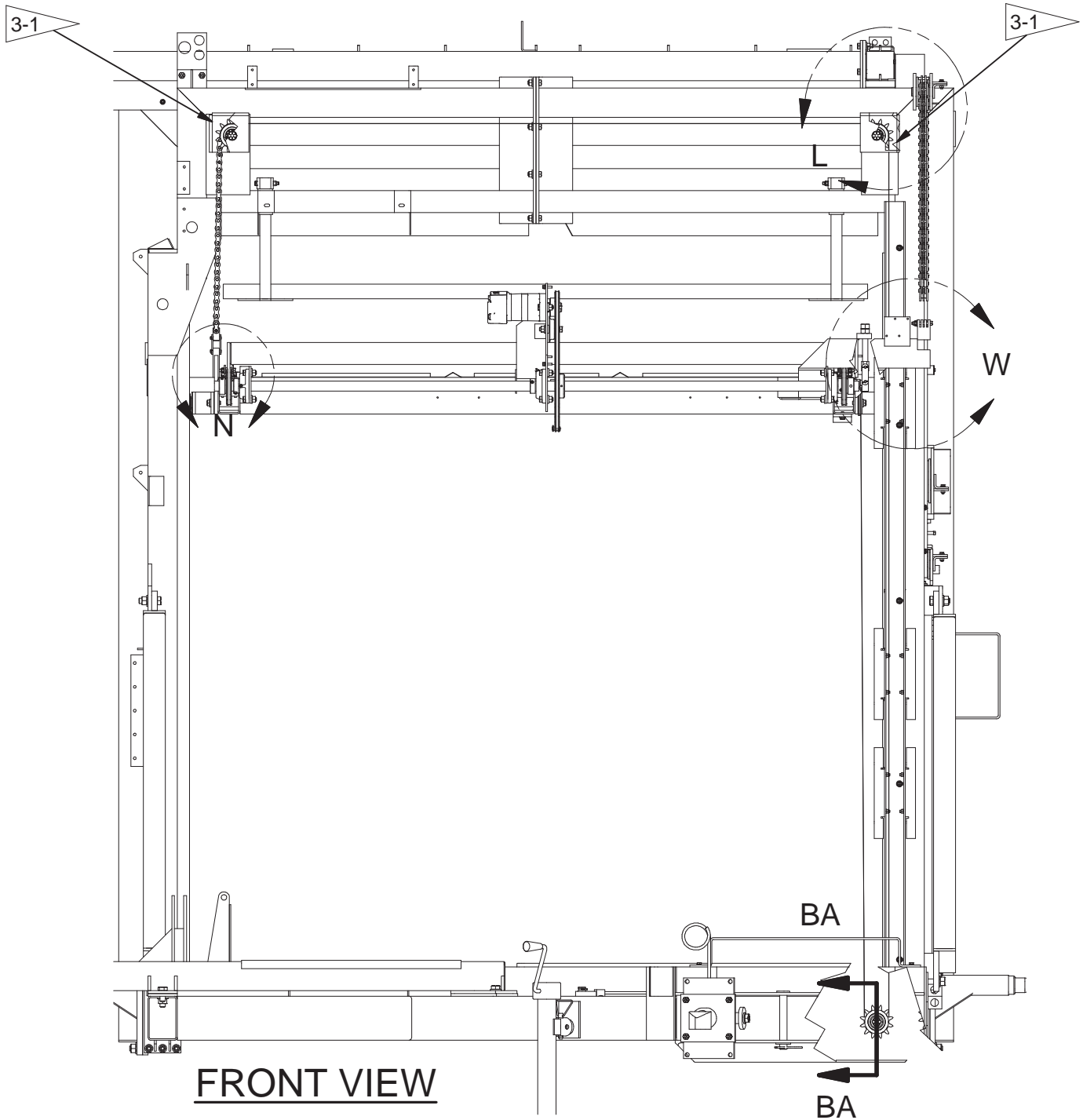

Load Bed Installation

Page 6 of 11

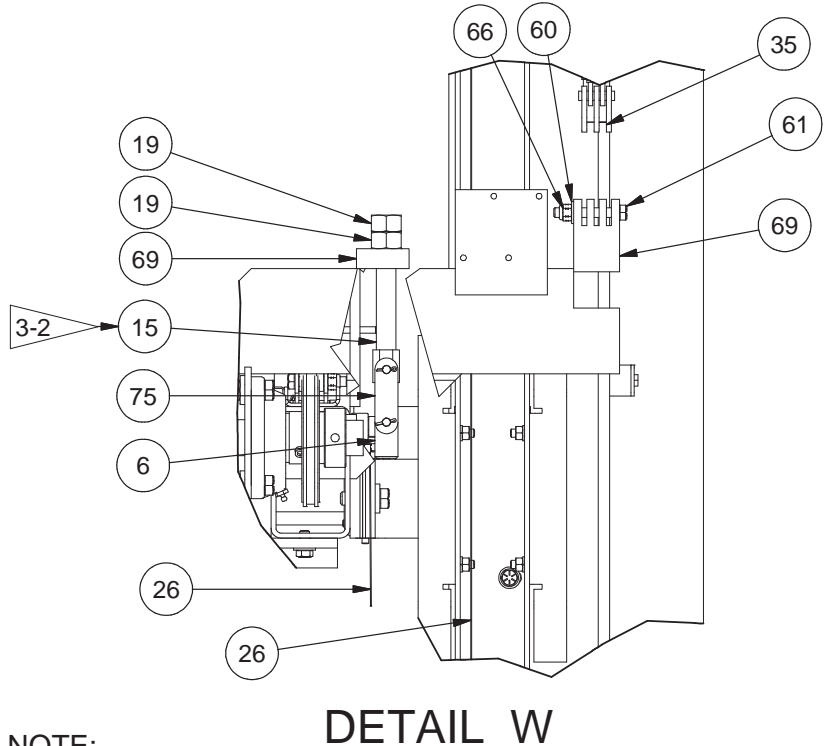
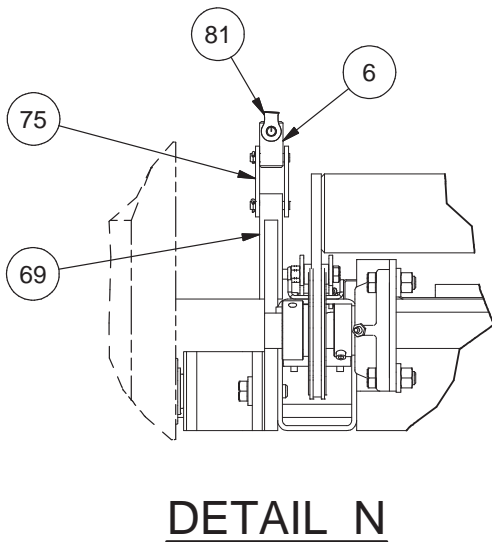
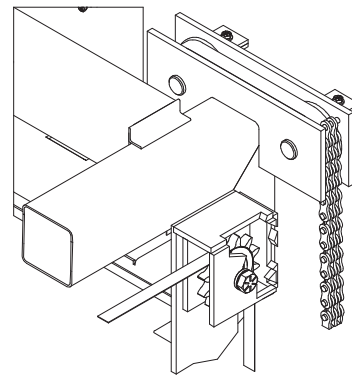
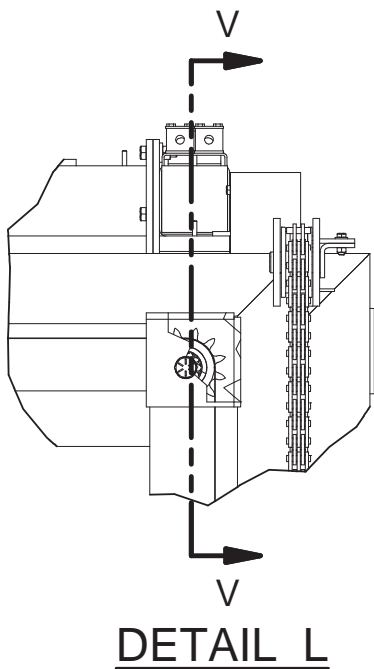
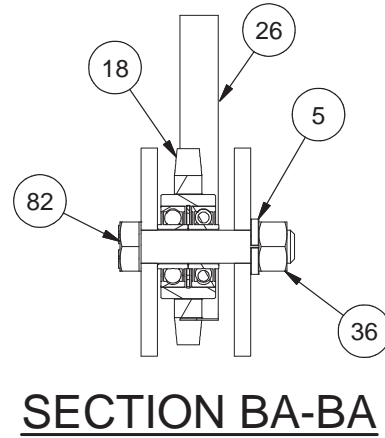
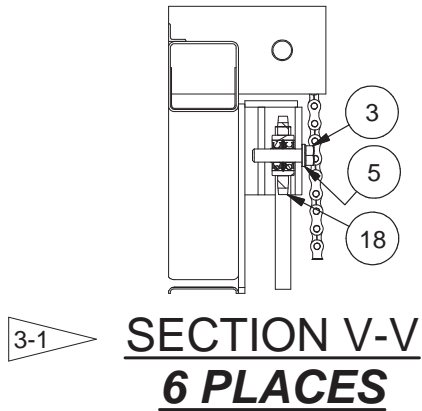

NOTE:

3-1 ALL CORNER SPROCKETS INSTALLED THE SAME

Load Bed Installation

Page 7 of 11

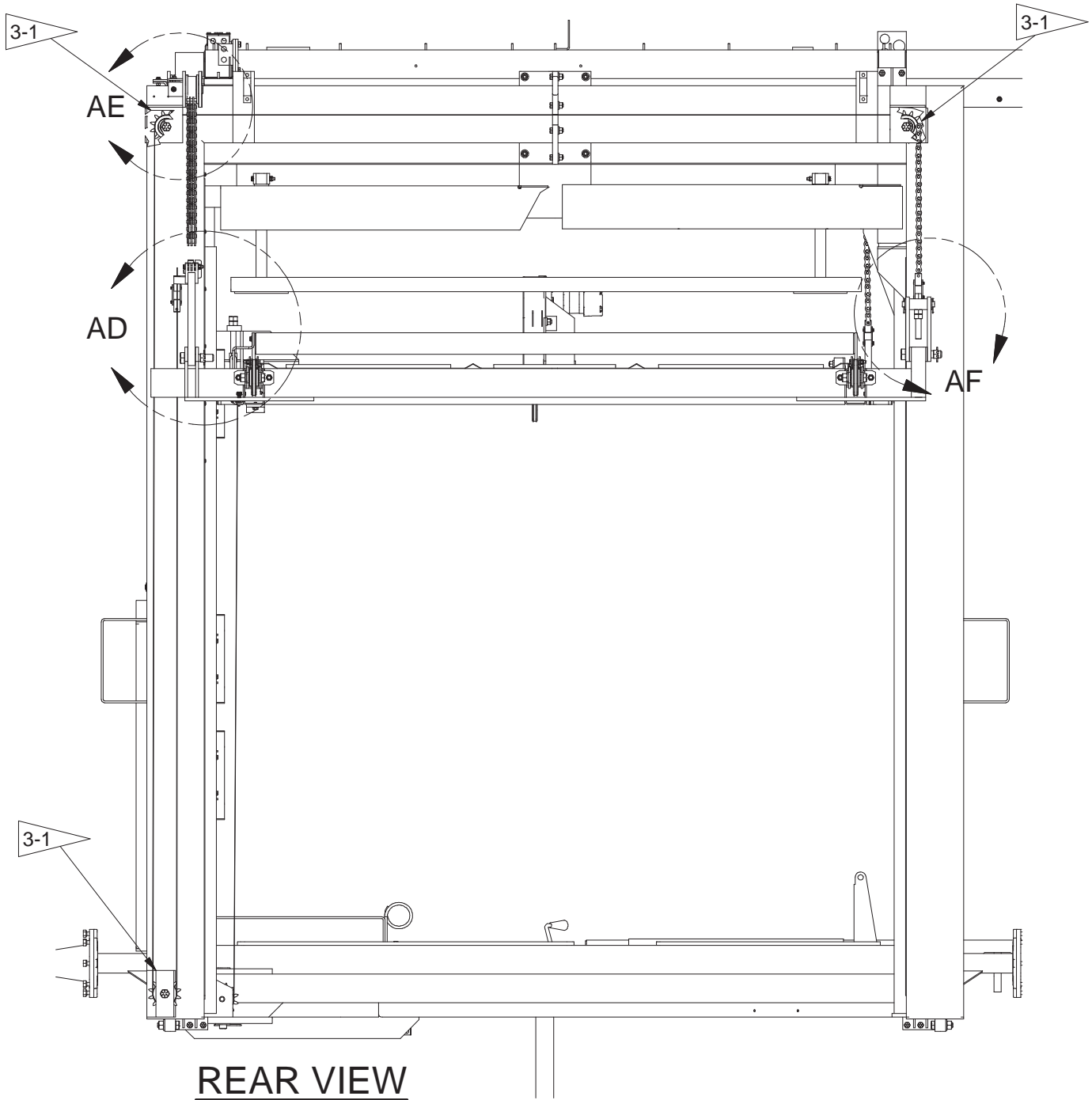

Load Bed Installation

Page 8 of 11

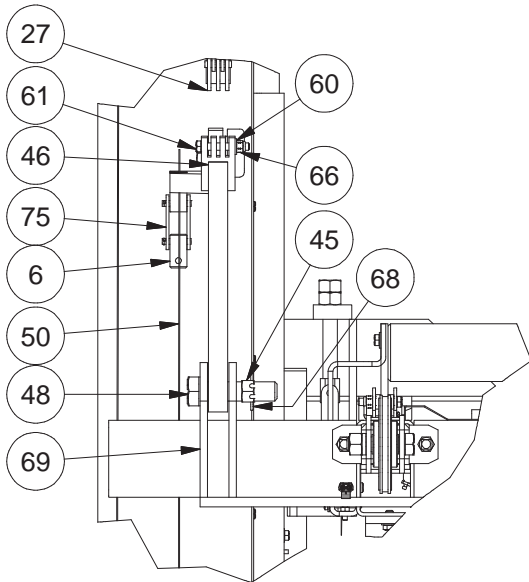

DETAIL AD

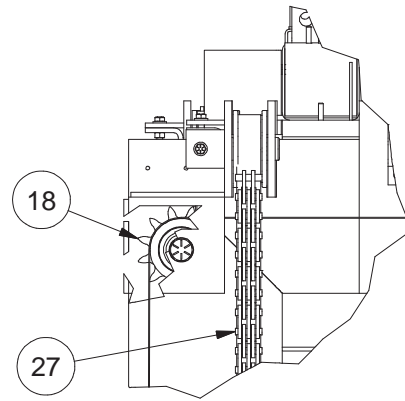

DETAIL AE

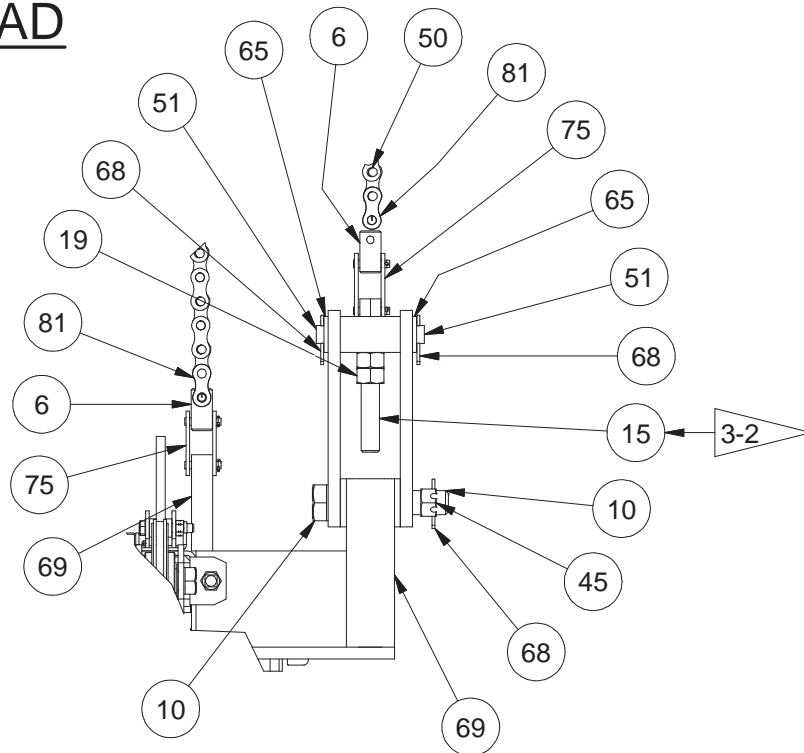

DETAIL AF

NOTE:
 3-2 LEVEL THE LOAD BED TO WITHIN A DIFFERENCE OF NO MORE THAN 0.8" ACROSS THE LENGTH OF THE LOAD BED FROM THE FRONT OF THE LOAD BED TO THE BACK OF THE LOAD BED AND FROM THE LH SIDE OF THE LOAD BED TO THE RH SIDE OF THE LOAD BED. USE THE ADJUSTING BOLTS TO ACHIEVE THIS. THERE MUST BE AT LEAST THREE (3) THREADS PROTRUDING PAST THE NUT WHEN THE FINAL ADJUSTMENT IS ACHIEVED.

Load Bed Installation

Page 9 of 11

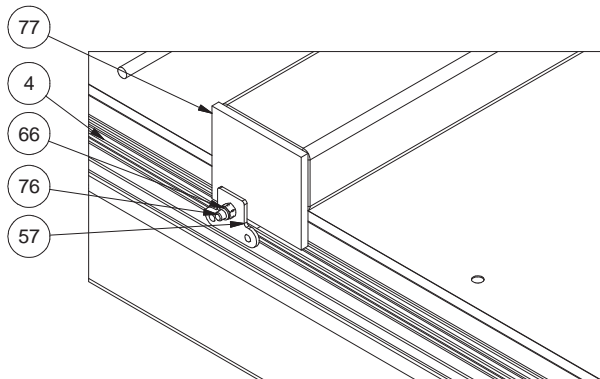
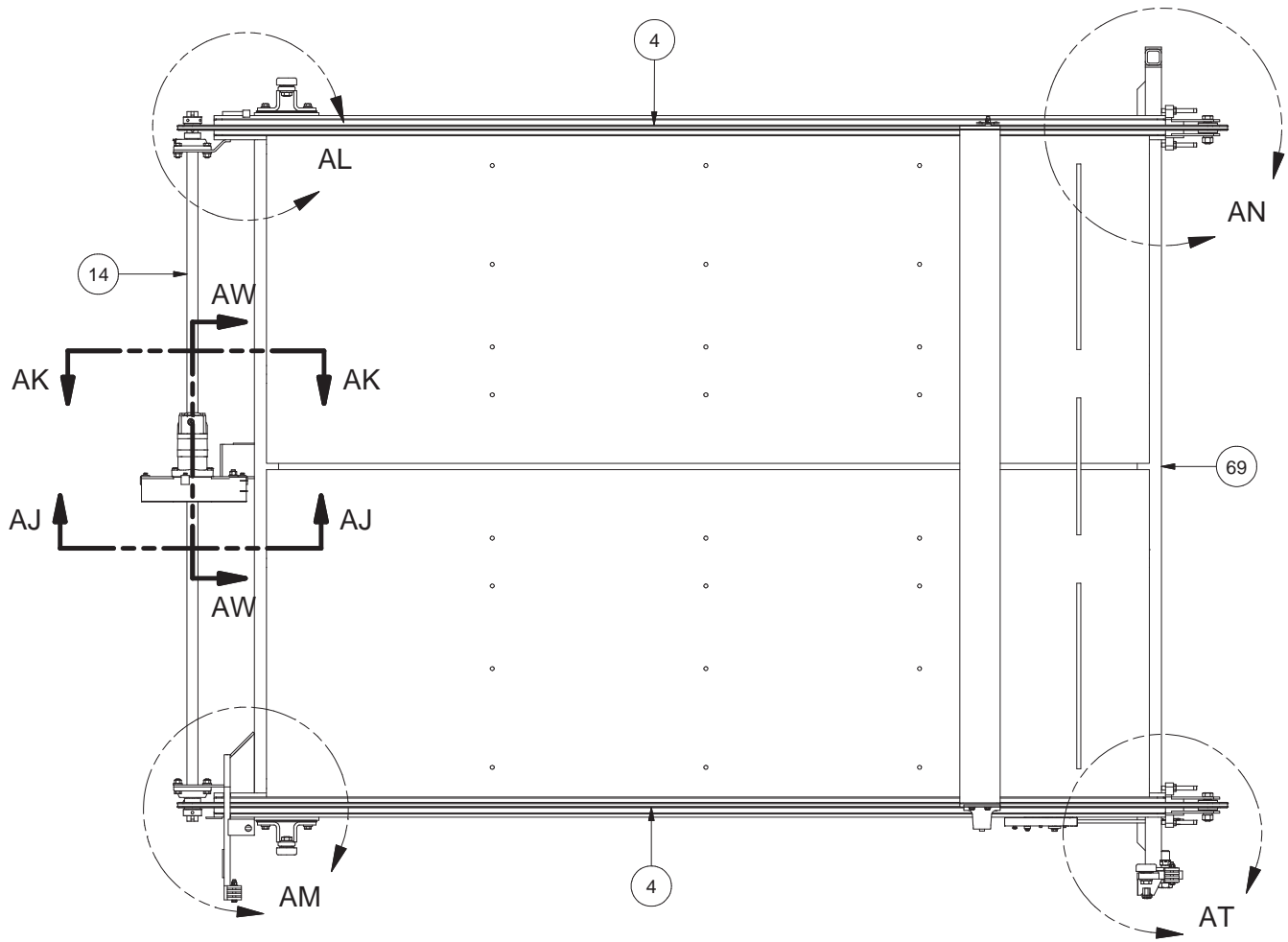

PUSH OFF BAR CHAIN INSTALL
2 PLACES

Load Bed Installation

Page 10 of 11

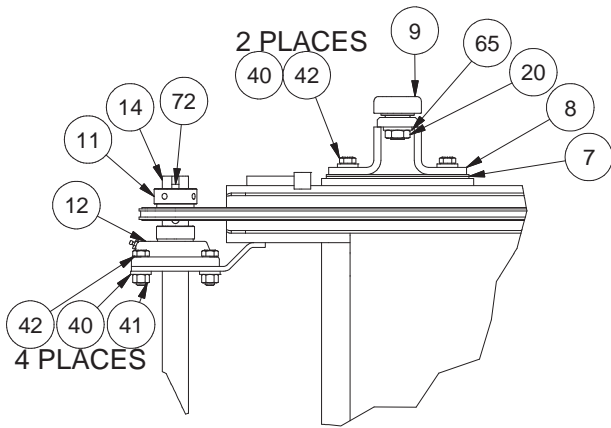

DETAIL AL

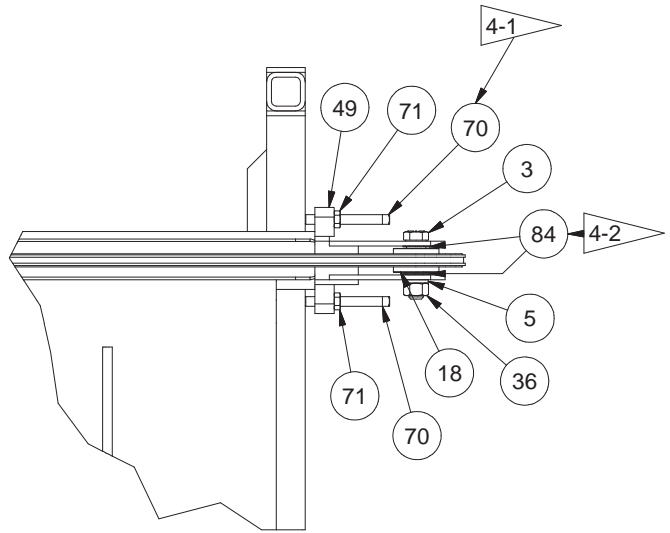

DETAIL AN

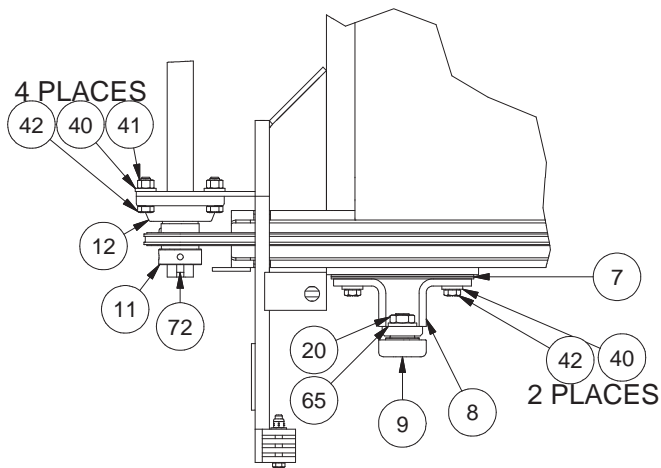

DETAIL AM

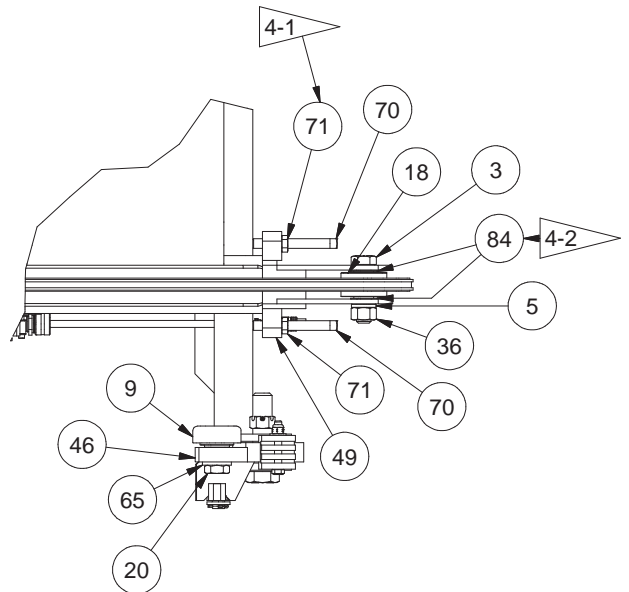

DETAIL AT

NOTES:

4-1 TENSION THE PUSH-OFF CHAINS TO PROVIDE CLEARANCE TO INSIDE WALL OF BED TUBE.

4-2 SHIMS TO TAKE UP SPACE

Load Bed Installation

Page 11 of 11

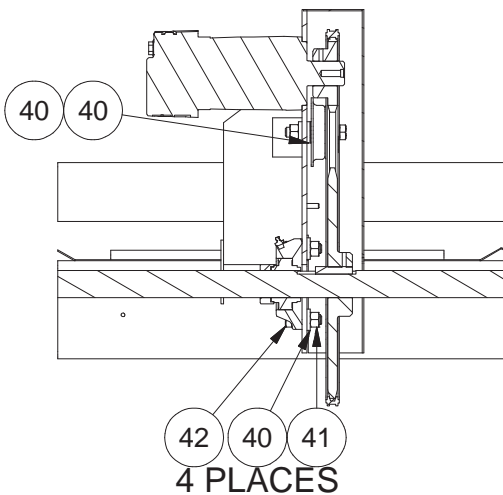
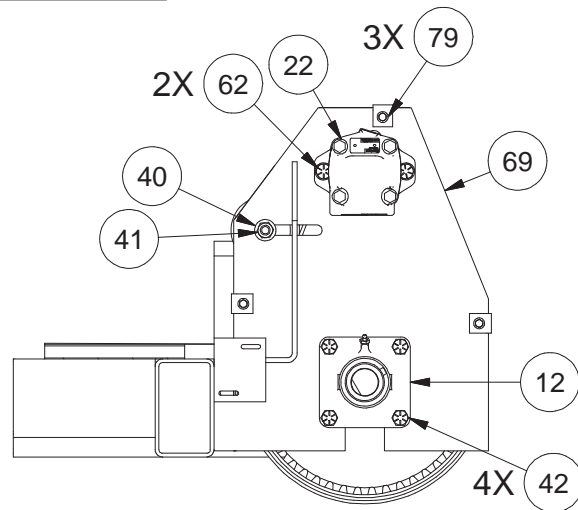
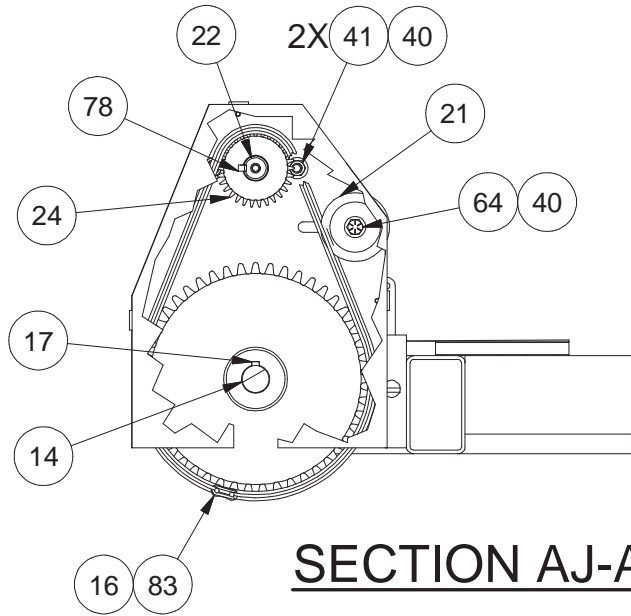

Cylinder Head Assembly

Page 1 of 1

Item	Part No.	Qty	Description	Item	Part No.	Qty	Description
	904948		Cylinder Head Assembly				
1	DRW0073291	1	. Cylinder Head	4	R13811014	1	. Capscrew
2	902871	2	. Roller, Cylinder Head	5	R13802914	1	. Hard Washer
3	PIN0033547	1	. Pin, Cylinder Head	6	221705W	1	. Hex Nut

Rev -

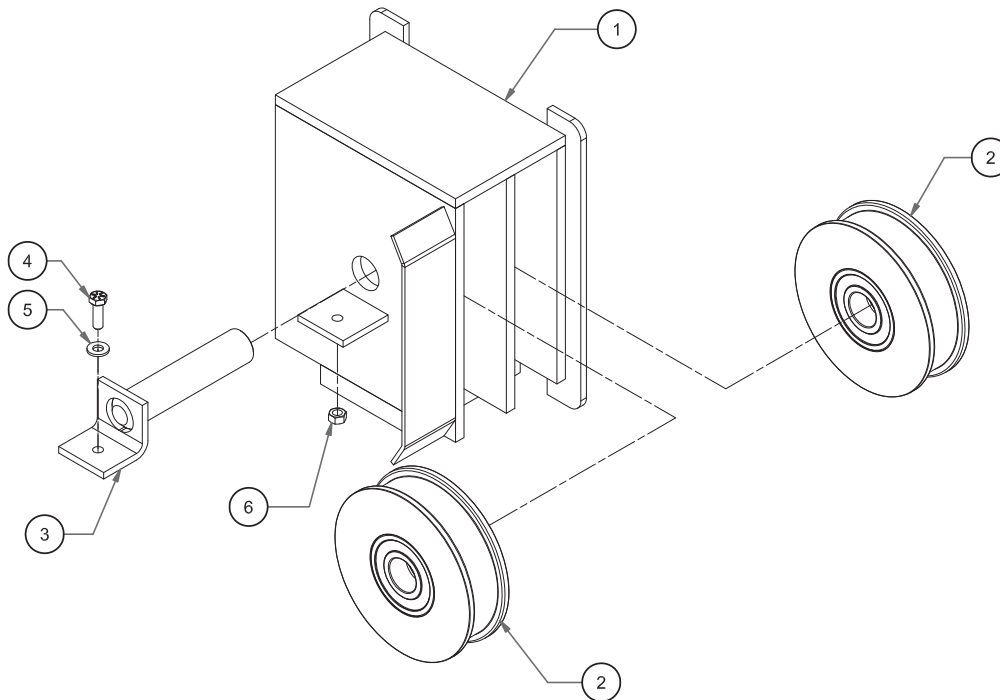

Limit Switch Installation, LS-15, Push Off

Page 1 of 2

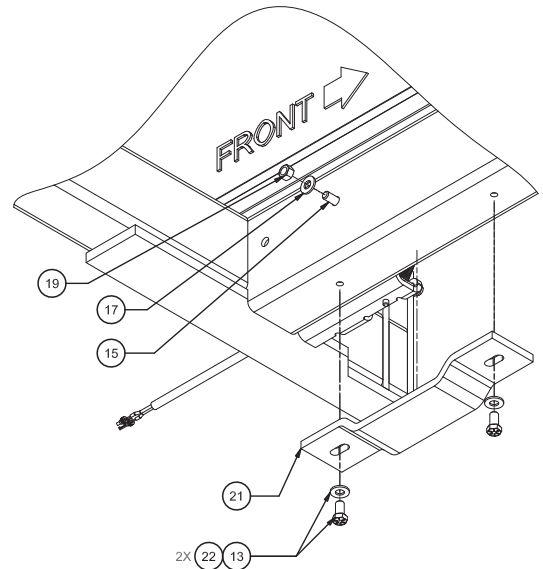
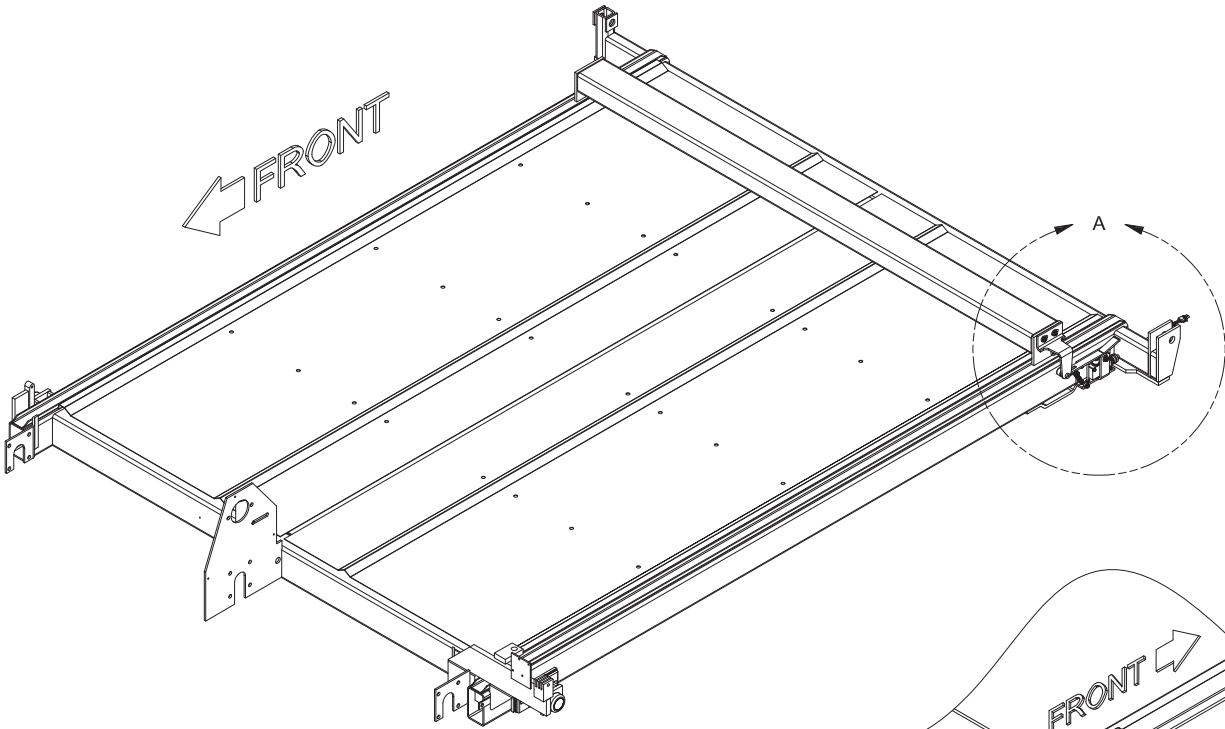

LIMIT SWITCH MOUNTING DETAIL

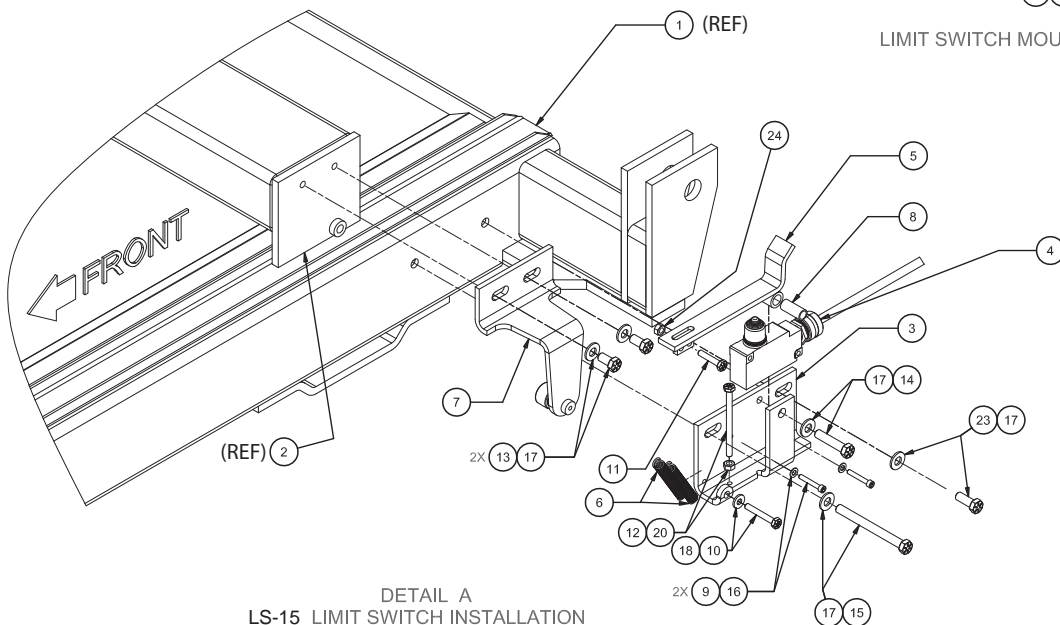

DETAIL A
LS-15 LIMIT SWITCH INSTALLATION

Limit Switch Installation, LS-15, Push Off

Page 2 of 2

Item	Part No.	Qty	Description	Item	Part No.	Qty	Description
904863				Limit Switch Install, Push Off			
1	BED0073275	Ref	. Bed	15	R13811047	1	. Capscrew
2	BAR0073345	Ref	. Push Off Bar	16	258762	2	. Flat Washer
3	904857	1	. Plate, Mounting	17	Y27E-06	6	. Washer
4	* 908336	1	. Limit Switch Assembly (Page 105)	18	221763W	1	. Washer
5	907943	1	. Actuator	19	221707W	1	. Hex Nut
6	F000004115	2	. Spring, Ext	20	221703W	1	. Hex Nut
7	* 904855	1	. Roller Mount Assembly (Page 45)	21	905071	1	. Shield, Harness
8	904862	1	. Bushing, Actuator	22	221767W	2	. Washer
9	18093W	2	. Capscrew	23	Y17C-0616	1	. Capscrew
10	R13810996	1	. Capscrew	24	235620	1	. Nut, ESNA
11	R13801782	1	. Capscrew				
12	234867	1	. Capscrew		* See Separate Page		
13	162572W	4	. Capscrew				Rev E
14	R13801813	1	. Capscrew				

This page is intentionally left blank.

Roller Mount Assembly

Page 1 of 1

Item	Part No.	Qty	Description	Item	Part No.	Qty	Description
	904855		Roller Mount Assembly				
1	904856	1	. Plate, Mounting				
2	257265	1	. Follower, Cam				
3	904018	1	. Tube				

Rev -

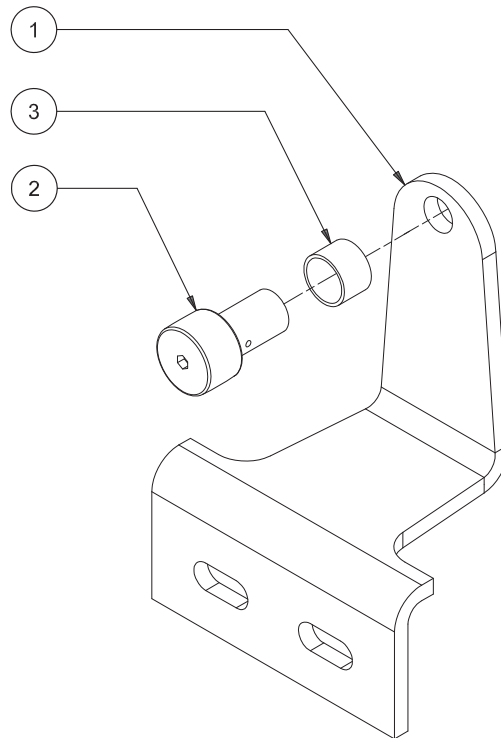

Bale Table Installation

Page 1 of 6

NOTE:

SELECT MOUNTING HOLE IN TABLE SUPPORT ARMS SUCH THAT THE BALE TABLE FRAME IS 90° TO THE BALE WAGON RIGHT HAND FRAME.

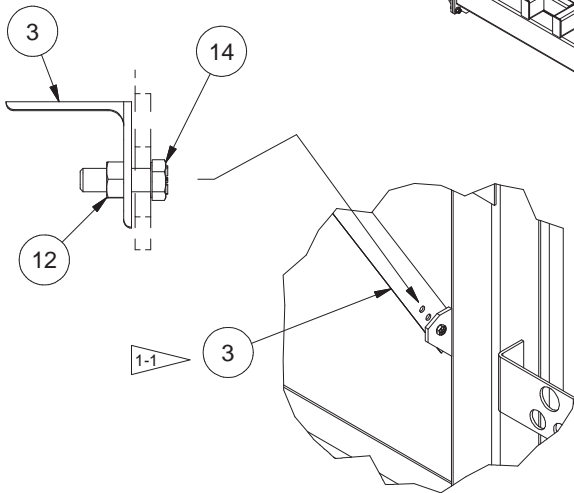
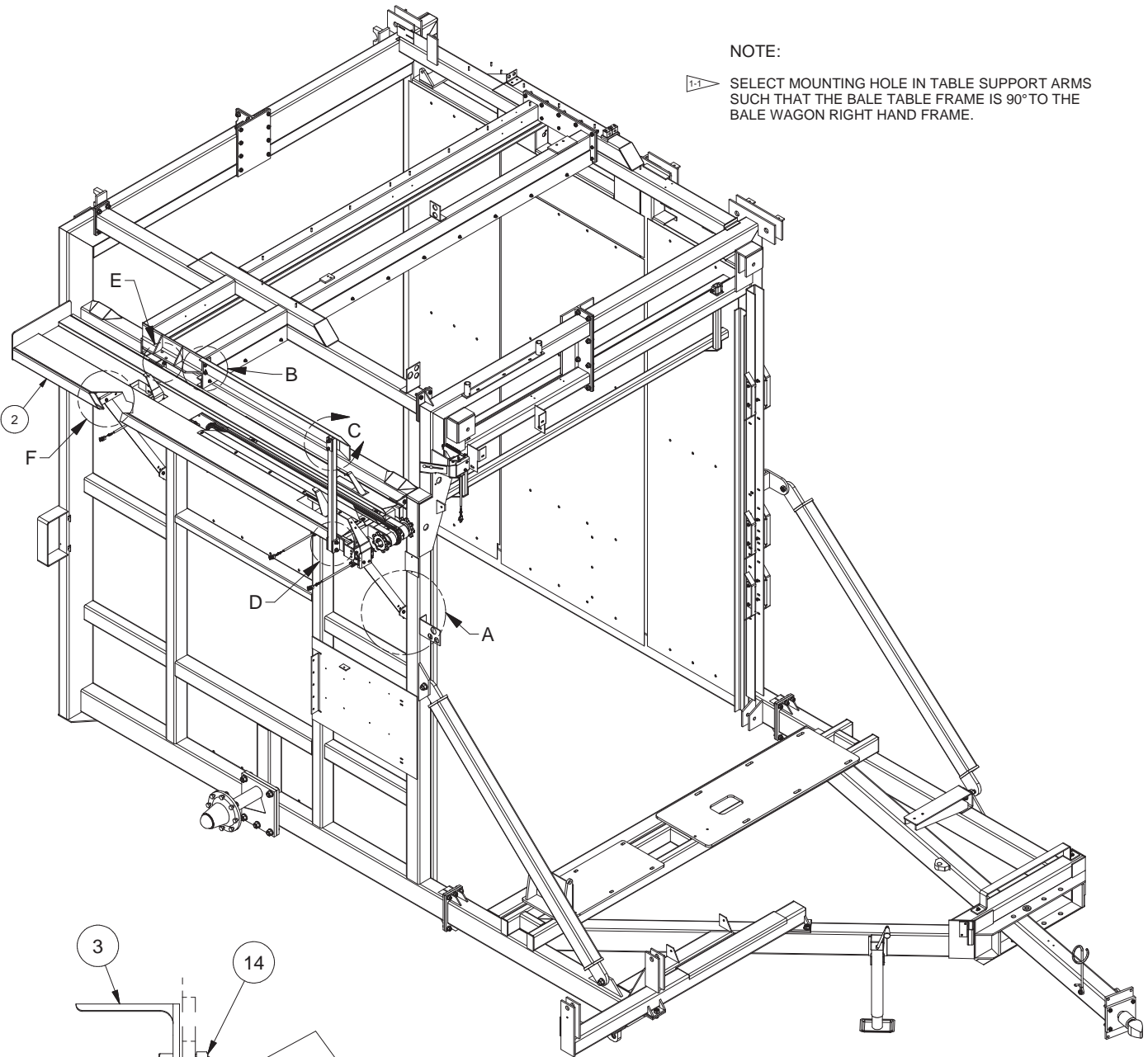

DETAIL A
2 PLACES

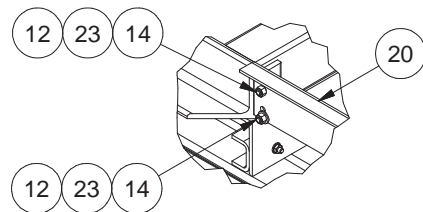

DETAIL B

Bale Table Installation

Page 2 of 6

Item	Part No.	Qty	Description	Item	Part No.	Qty	Description
904834 Bale Table Installation							
2	904873	1	. Frame, Bale Table	30	R13810992	2	. Capscrew
3	SUP0073075	2	. Angle, Support	31	904833	1	. Actuator Assembly
4	11-258	4	. Bracket		MNT032804	1	.. Mounting Plate
5	BKT0073077	1	. Bracket		904832	1	.. Actuator Extension
6	MNT0032804	1	. Plate, Mounting	32	11-260	4	. Pin
7	ACT0073458	1	. Plate, Trip Mount	33	ZZ00002016	10	. Set Collar
8	MNT0032794	1	. Bracket, Mounting	34	904885	1	. Pin
9	TRK0016931	1	. Track, Bale Table Chain	35	R13802914	8	. Hard Washer
10	MTR00RSAK1	1	. Motor, Hydraulic	36	221705W	16	. Hex Nut
11	SPK0060172	2	. Sprocket	37	00103385	10	. Cotter Pin
12	221707W	32	. Hex Nut	38	* 904997	4	. Limit Switch Assembly (Page 105)
13	Y17C-0616	10	. Capscrew	39	R132007	8	. Machine Screw
14	221497W	10	. Capscrew	40	SPK0025111	2	. Sprocket
15	904876	1	. Plate, Mounting	41	02-104	2	. Flange Bearing
16	904875	1	. Plate, Trip	42	SHF0073076	1	. Shaft
17	904874	1	. Plate, Actuator	43	48688	3	. Key
18	233972	4	. Bolt, Carr	44	R13811013	4	. Capscrew
19	SUP0073512	1	. Support, Front	45	GUD0016919	1	. Plate, Guide
20	GUD0073511	1	. Plate, Guide	46	Y25G-0410	6	. Capscrew
21	Y09G-0616	4	. Capscrew	47	R13810993	9	. Capscrew
22	221499W	8	. Capscrew	48	F000000278	5	. Spring, Tension
23	221767W	32	. Washer	49	R13811014	4	. Capscrew
24	R13811042	2	. Capscrew	50	R13810996	1	. Capscrew
25	180959W	2	. Capscrew	51	905096	1	. Bar, Mounting
26	R13811083	1	. Capscrew	52	CHN0032522	1	. Table Chain Complete
27	221711W	2	. Hex Nut	53	MNT0032787	1	. Mounting Weldment
28	221763W	8	. Washer	54	904239	1	. Plate, Mounting
29	221703W	28	. Hex Nut	55	CNK0002060	1	. Connecting Link

* See Separate Page

Rev G

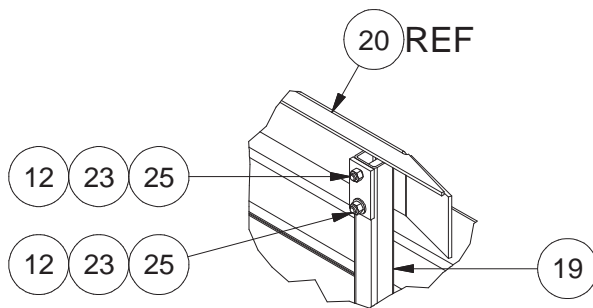

DETAIL C

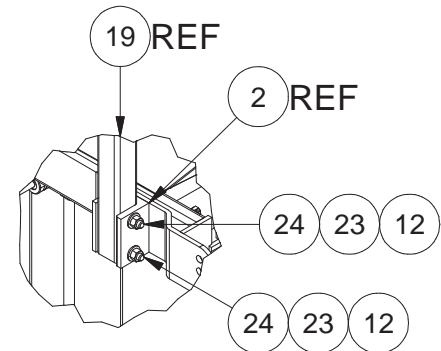

DETAIL D

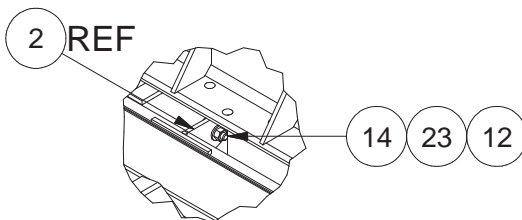

DETAIL E
2 PLACES

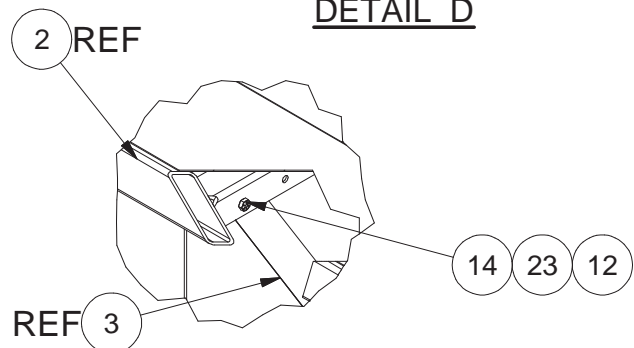

DETAIL F
2 PLACES

Bale Table Installation

Page 3 of 6

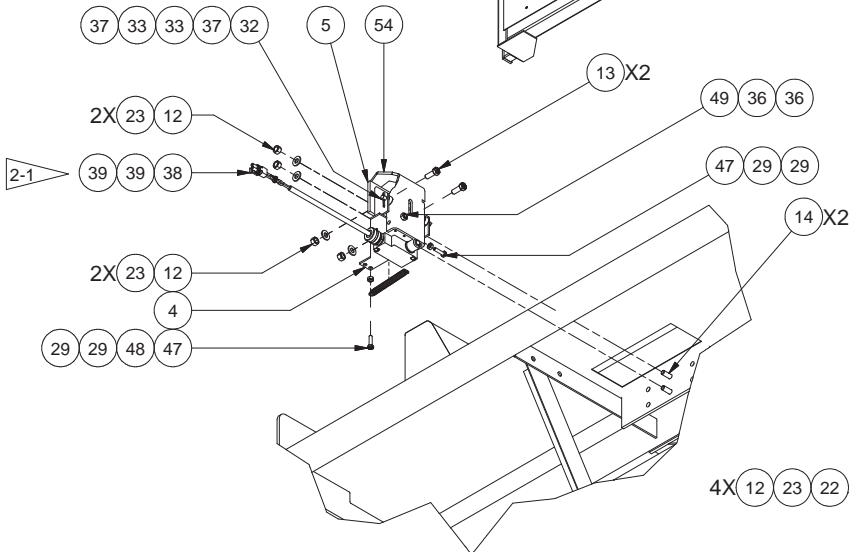
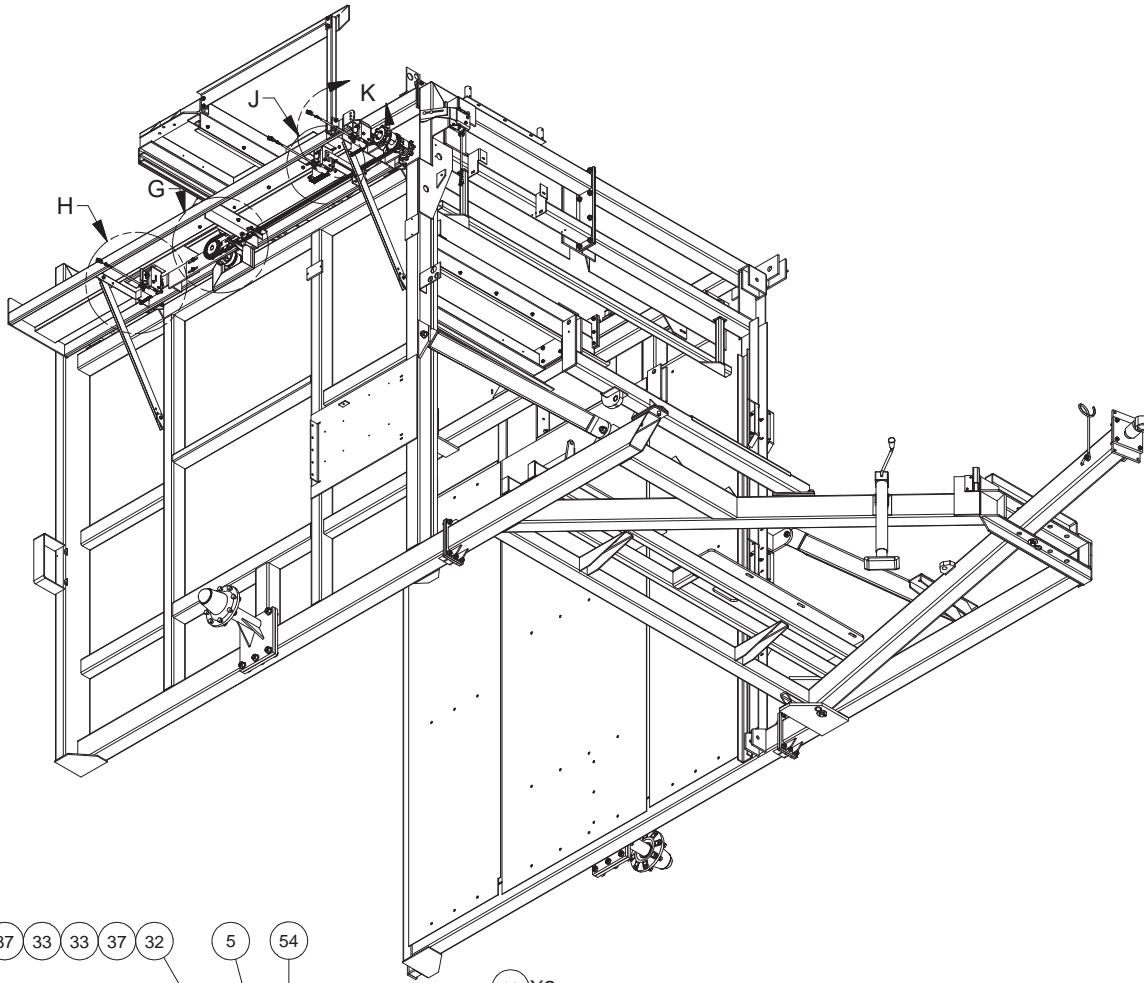

DETAIL H
LS-1

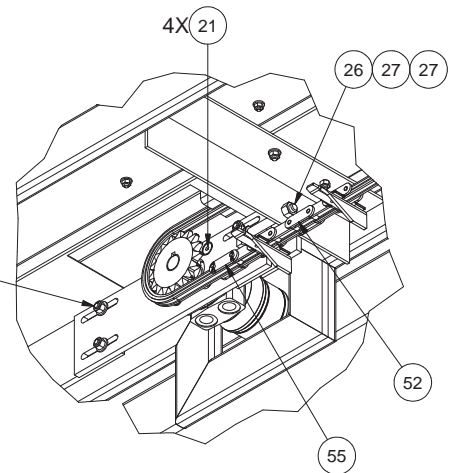

DETAIL G

NOTES:

2-1 SETUP ACTUATOR STOP TO ACTIVATE SWITCH, BUT NOT BOTTOM OUT SWITCH BUTTON.

2-2 WASHERS USED AT TOP OF ELEVATOR TABLE SUPPORT (ITEM 3)

Bale Table Installation

Page 4 of 6

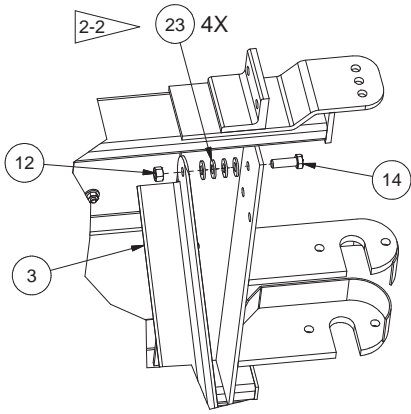
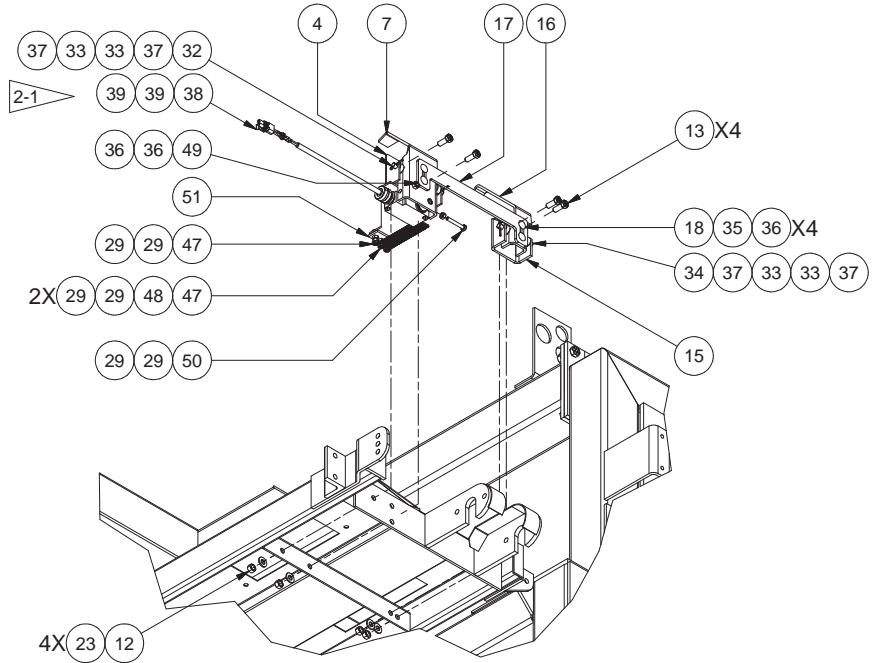
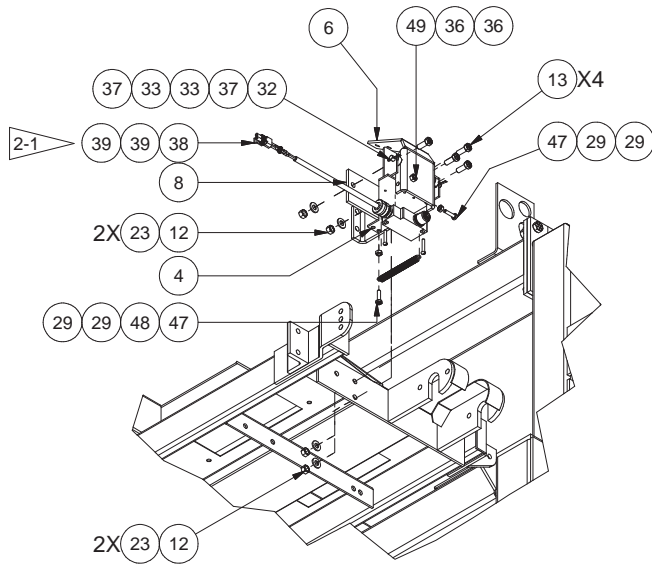

TABLE SUPPORT ANGLE



DETAIL J
LS-8



DETAIL K
LS-9

Bale Table Installation

Page 5 of 6

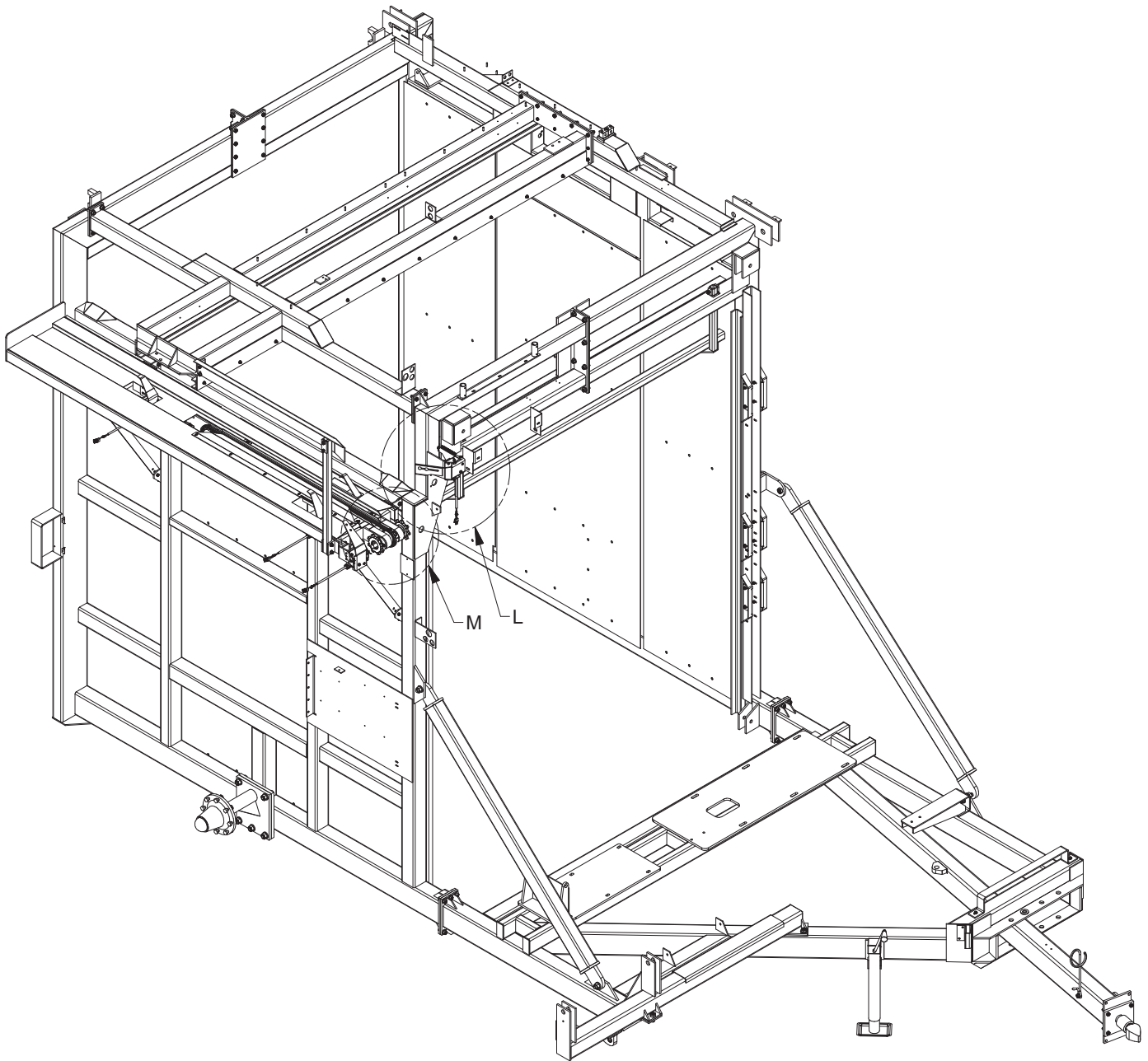

NOTE:

3-1 SETUP ACTUATOR STOP TO ACTIVATE SWITCH, BUT NOT BOTTOM OUT SWITCH BUTTON.

Bale Table Installation

Page 6 of 6

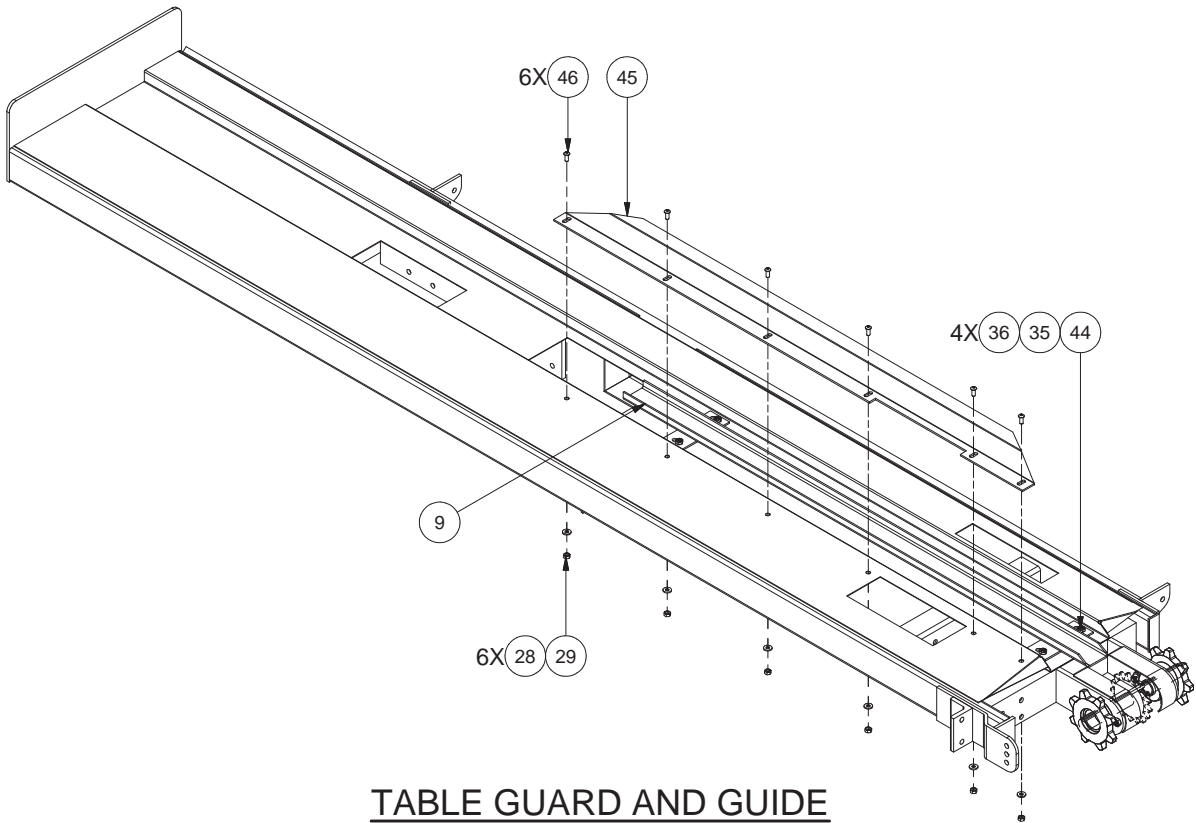
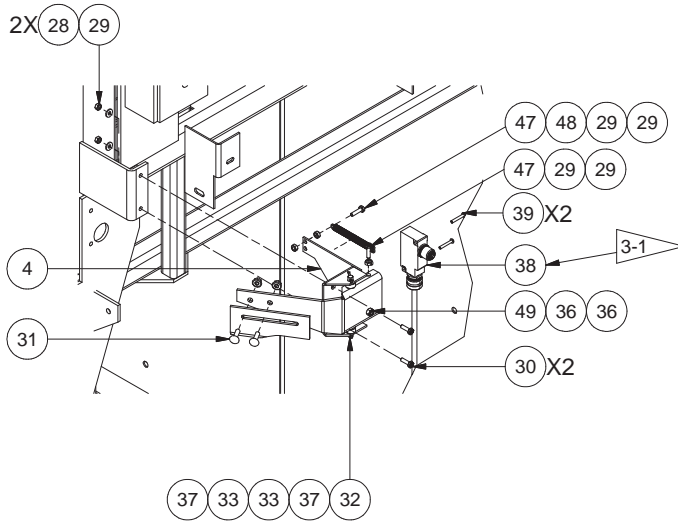
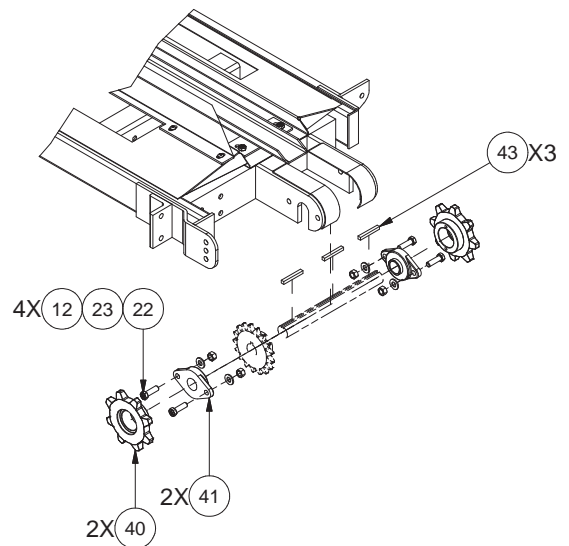

TABLE GUARD AND GUIDE



**DETAIL L
LS-14**



**DETAIL M
SPROCKET**

Safety Gate Installation

Page 1 of 2

NOTES:

- 1 - LOCATE MOUNTING HOLES AT ASSEMBLY.
- 2 - WELD IN PLACE AT ASSEMBLY. ITEM 4 MUST LATCH WITH ITEM 7 AFTER WELDING. VERIFY BEFORE WELDING ITEM 4 TO THE FRAME.
- 3 - WELD IN PLACE AT ASSEMBLY.

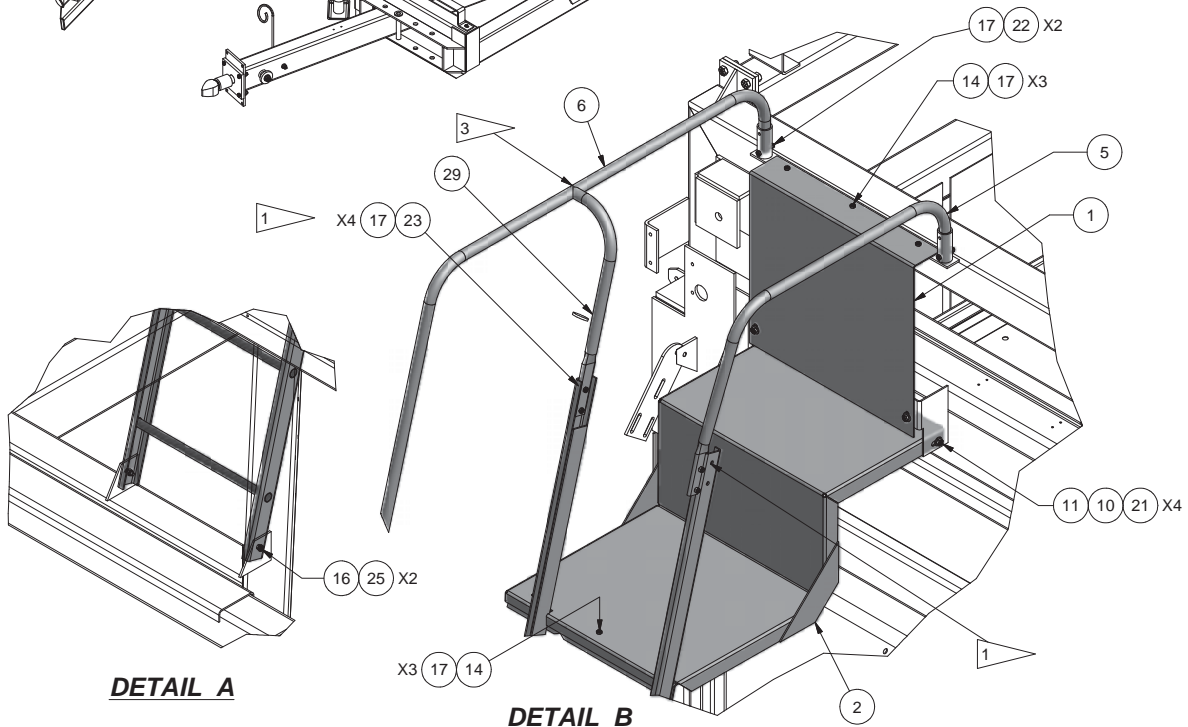
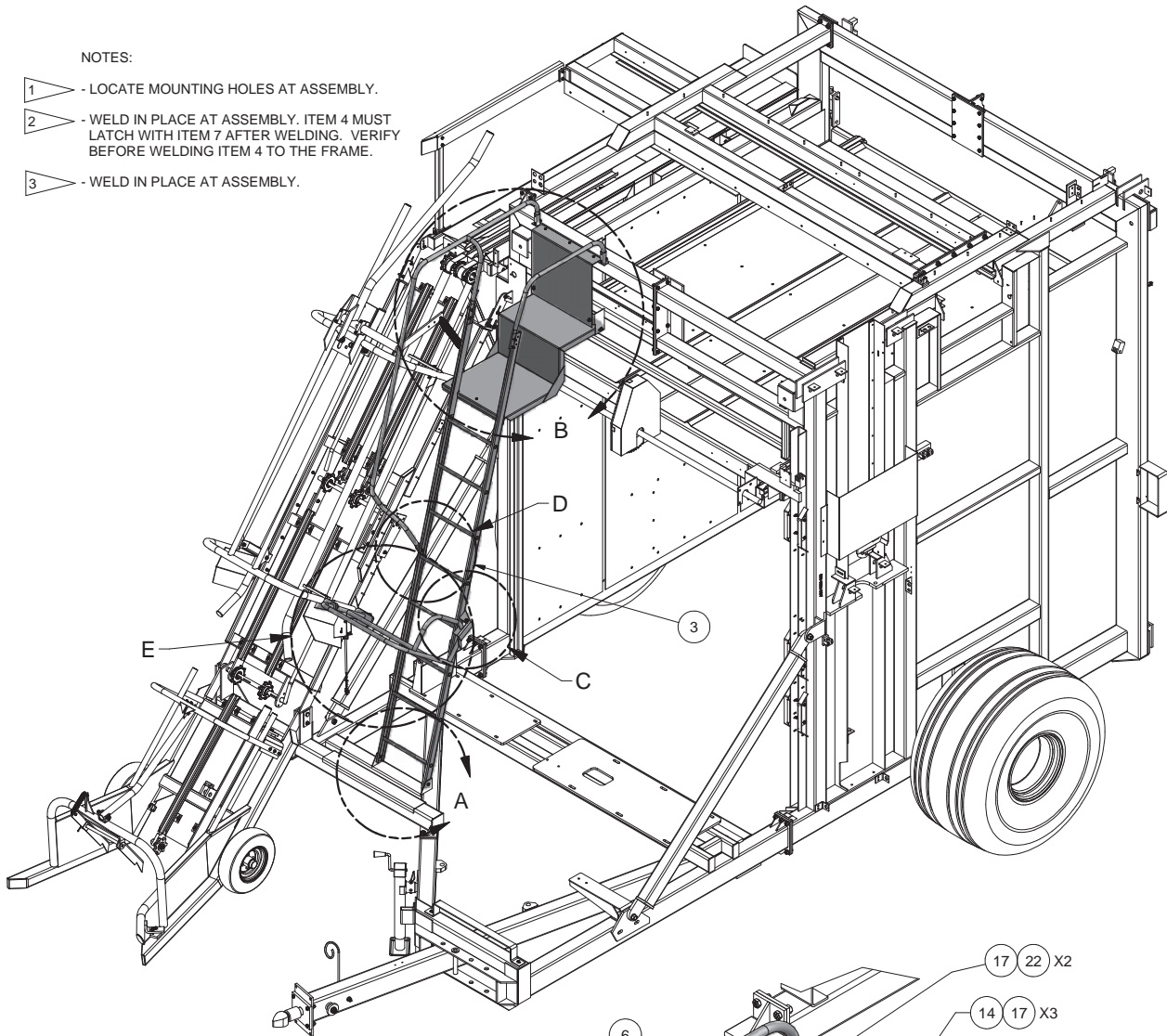

Safety Gate Installation

Page 2 of 2

Item	Part No.	Qty	Description	Item	Part No.	Qty	Description
904924 Safety Gate Installation							
01	MNT0016779	1	. Plate, Top	17	R13811189	12	. Locknut
02	FLP0016778	1	. Platform, Safety	19	R13811015	2	. Capscrew
03	LDR0016768	1	. Ladder	21	R13811191	4	. Locknut
04	906439	1	. Safety Gate	22	R13810996	2	. Capscrew
05	RAL0016777	1	. Handrail, LH	23	224120W	4	. Capscrew
06	DRW0016773	1	. Handrail, RH	24	R13801782	4	. Capscrew
07	LAT0016809	1	. Plate, Latch	25	232939	5	. Nut, Esna
10	221767W	4	. Washer	26	F000008147	1	. Bushing, Drive Rod
11	Y17C-0616	4	. Capscrew	27	R13811016	1	. Capscrew
14	R13810993	6	. Capscrew	28	R13802914	2	. Hard Washer
16	R13811014	2	. Capscrew	29	DRW0016774	1	. Handrail, RH

Rev E

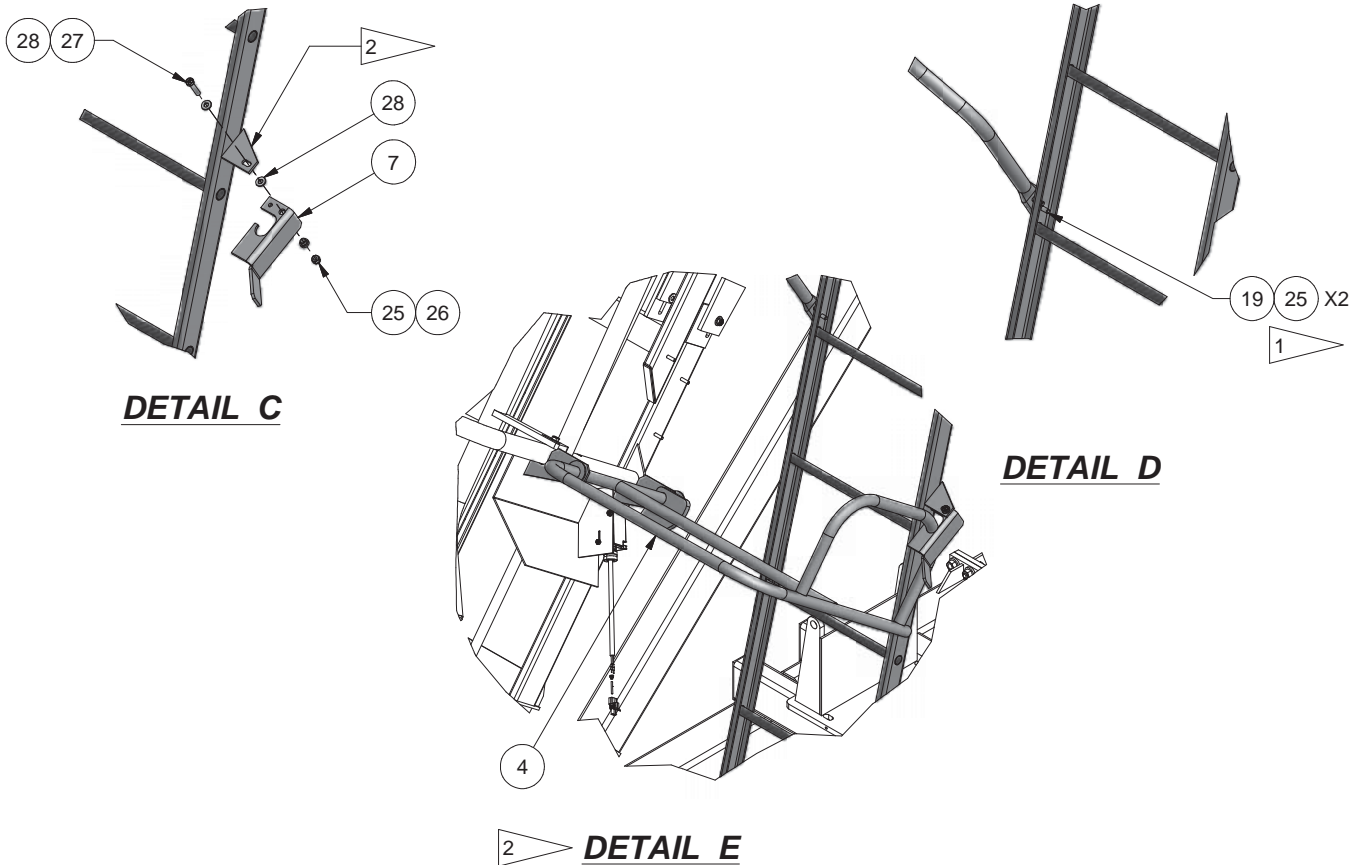

Pusher Assembly Installation

Page 1 of 2

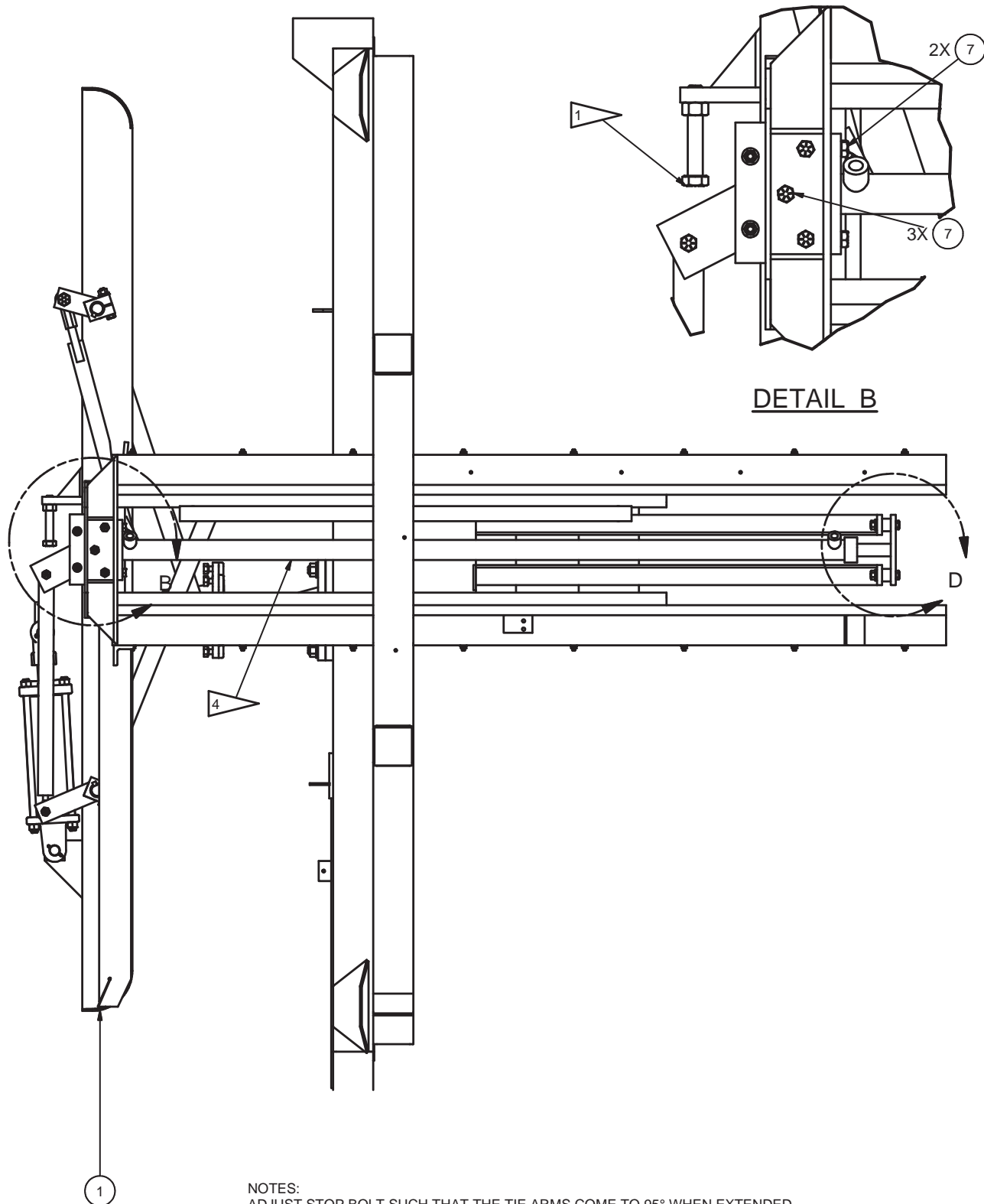

NOTES:
ADJUST STOP BOLT SUCH THAT THE TIE ARMS COME TO 95° WHEN EXTENDED.



ADJUST THE ROD ENDS SUCH THAT THE TIE ARMS ARE PARALLEL TO THE PUSHER FRAME WHEN THE TIE ARMS ARE RETRACTED.



SHIM AS NECESSARY SUCH THAT THE PUSHER CYLINDER EXTENDS AND RETRACTS WITHOUT THE PUSHER CYLINDER ROD BENDING OR BINDING.



REFERENCE CYLINDER INSTALLATION 904905

Pusher Assembly Installation

Page 2 of 2

Item	Part No.	Qty	Description	Item	Part No.	Qty	Description
	905070		Pusher Assembly Installation				
1	* 904822	1	. Tie Arm Installation (Page 57)	11	MNT0017140	1	. Pusher Cylinder Rod Mount
7	200454W	5	. Capscrew	12	SHM0034535	2	. Shim
8	221711W	7	. Hex Nut	13	SPC0017669	2	. Spacer
9	221771W	7	. Washer	14	221576W	2	. Capscrew

* See Separate Page

Rev C

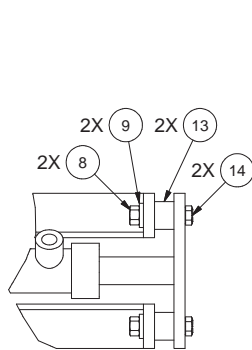

DETAIL D

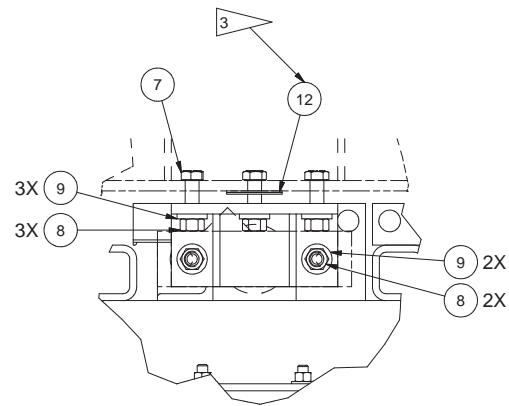

DETAIL C

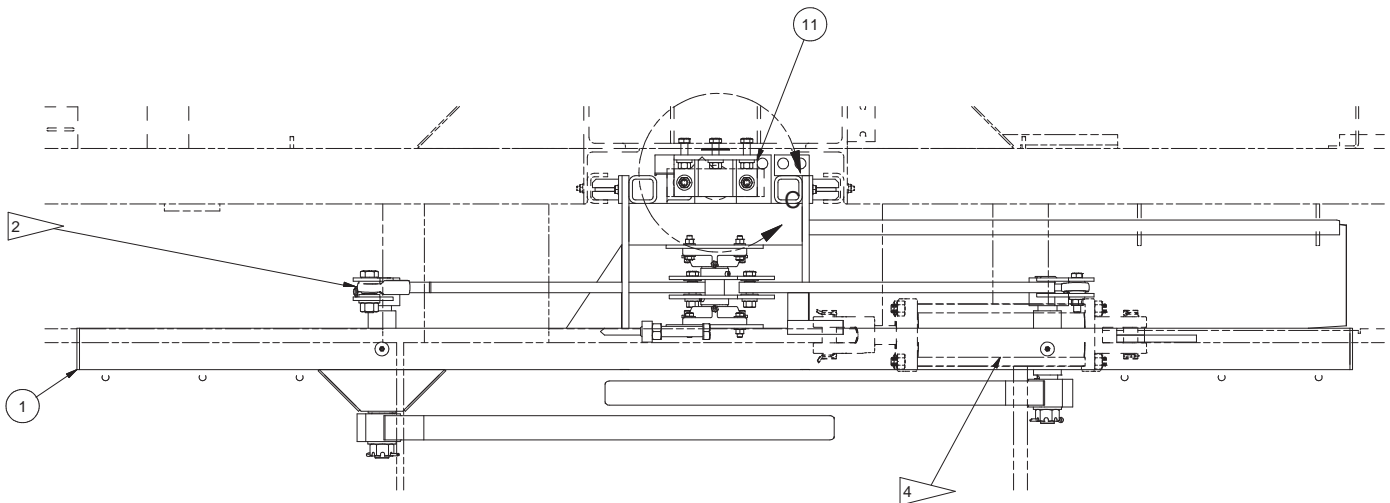

Tie Arm Installation

Page 1 of 4

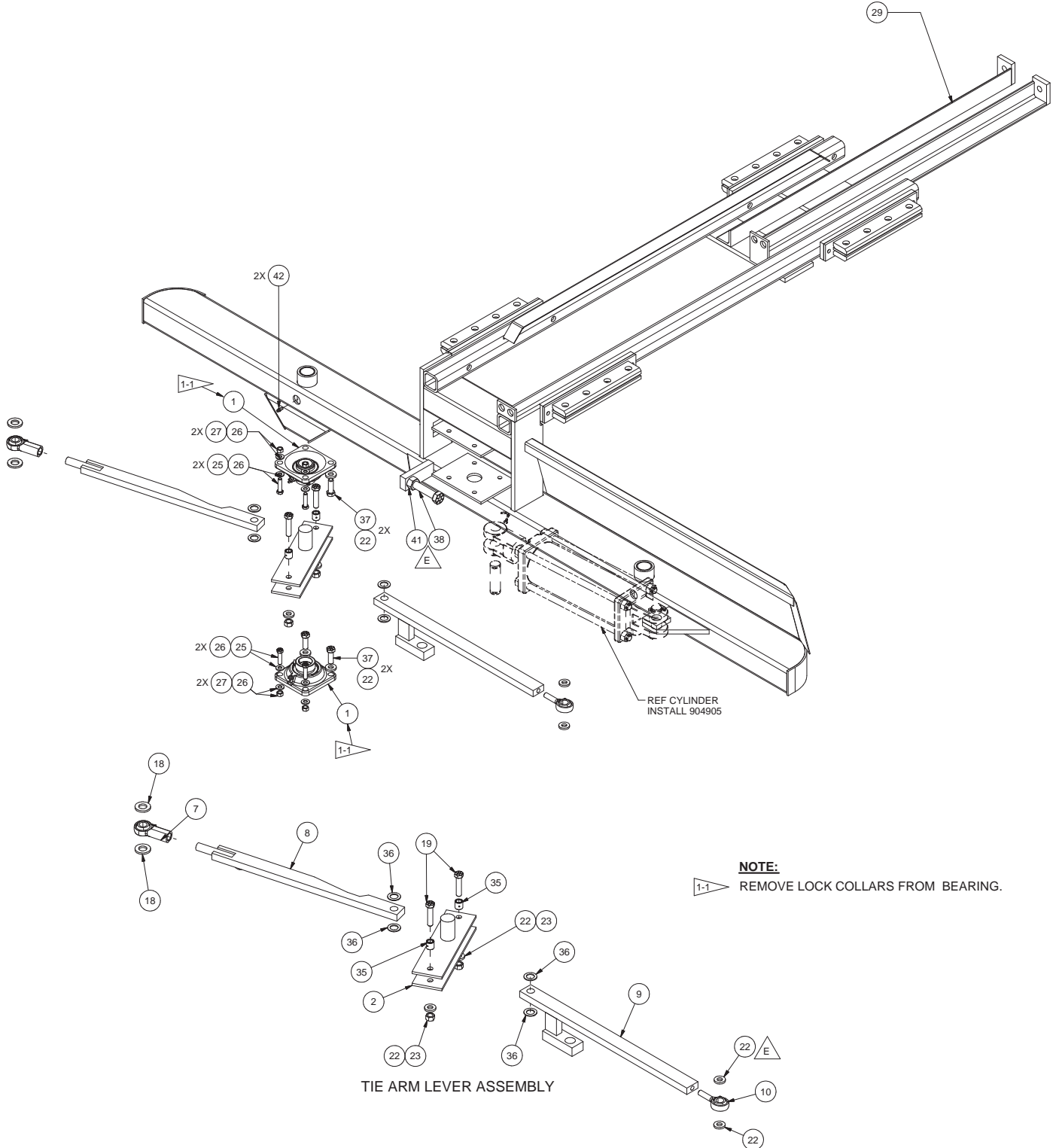

Tie Arm Installation

Page 2 of 4

Item	Part No.	Qty	Description	Item	Part No.	Qty	Description
904822			Tie Arm Installation				
1	BRGRCJ1375	2	. Flange Bearing	24	221576W	1	. Capscrew
2	BLT0073319	1	. Tie Pivot Arm	25	Y17C-0624	4	. Capscrew
3	LEV0073322	1	. Front Pusher Tie Arm Lever	26	221767W	8	. Washer
4	LEV0073323	1	. Rear Pusher Tie Arm Lever	27	221707W	4	. Hex Nut
5	F000007904	2	. Key	28	R13811080	2	. Capscrew
6	904820	1	. Tie Arm, LH	29	DRW0073472	1	. Pusher
7	F000001549	1	. Rod End, RH	30	MNT0016827	4	. Pusher Guide Pad Mount
8	LEV0073189	1	. Tie Arm Lever	31	SRP0016794	8	. Pad, Wear
9	LEV0073196	1	. Lever	32	R13810993	16	. Capscrew
10	F000005992	1	. Male Rod End	33	Y17C-0616	8	. Capscrew
12	904818	1	. Shaft, LH Tie Arm	34	00274551	16	. Nut, Serrated
13	904821	1	. Tie Arm, RH	35	F000007607	2	. Bearing, Inner Race
14	212255	2	. Cotter Pin	36	ZZ00000206	4	. Mach Bushing
15	NSL0001000	2	. Nut, Castle	37	200454W	4	. Capscrew
16	221780W	2	. Washer	38	Y17C-1272	1	. Capscrew
17	904819	1	. Shaft, RH Tie Arm	39	F000004104	2	. Key
18	221777W	3	. Washer	40	221763W	16	. Washer
19	221574W	2	. Capscrew	41	221716W	2	. Hex Nut
20	221657W	1	. Capscrew	42	F000006170	2	. Zerk
22	221771W	11	. Washer				
23	221711W	5	. Hex Nut				

Rev E

Tie Arm Installation

Page 3 of 4

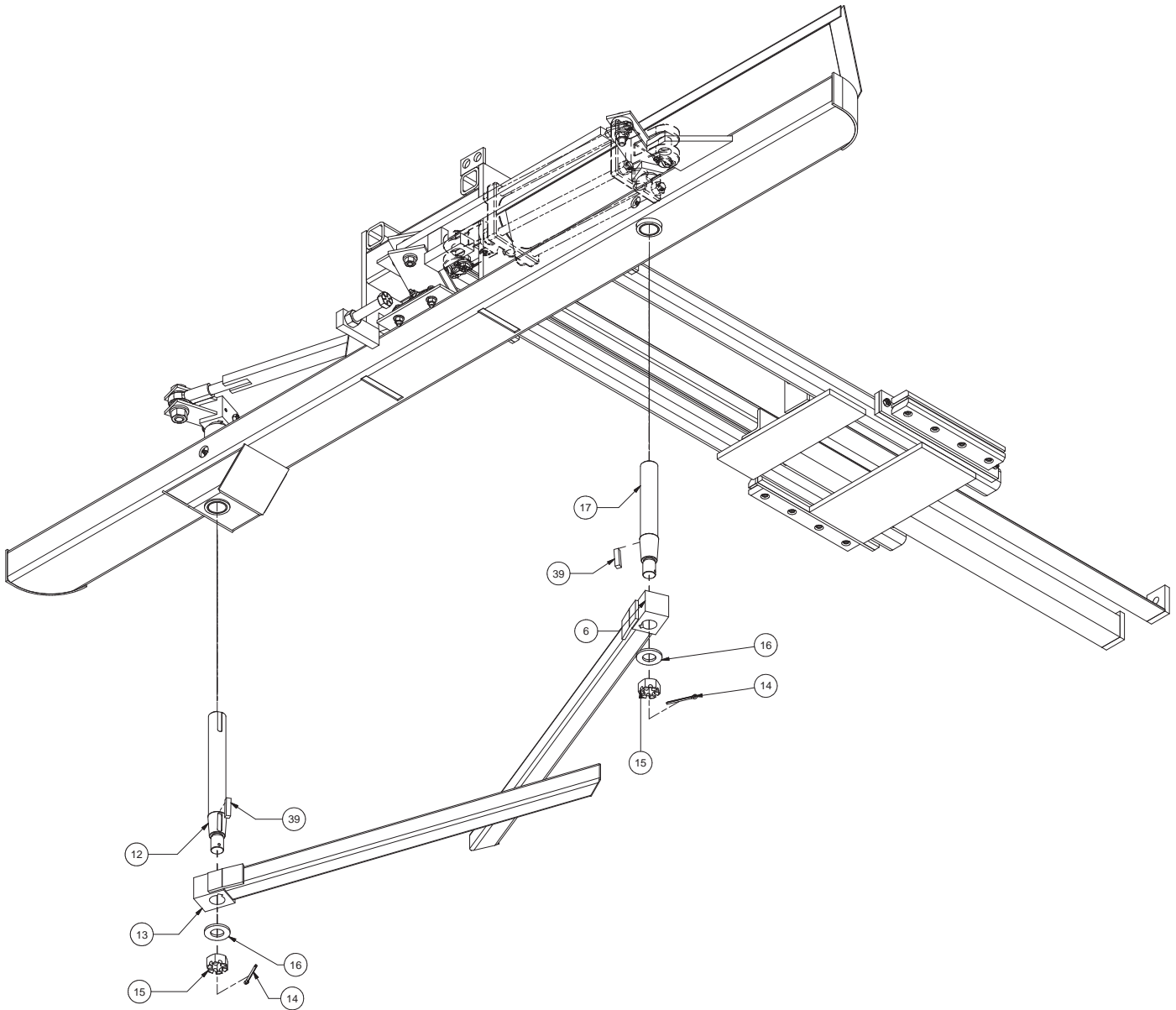

Tie Arm Installation

Page 4 of 4

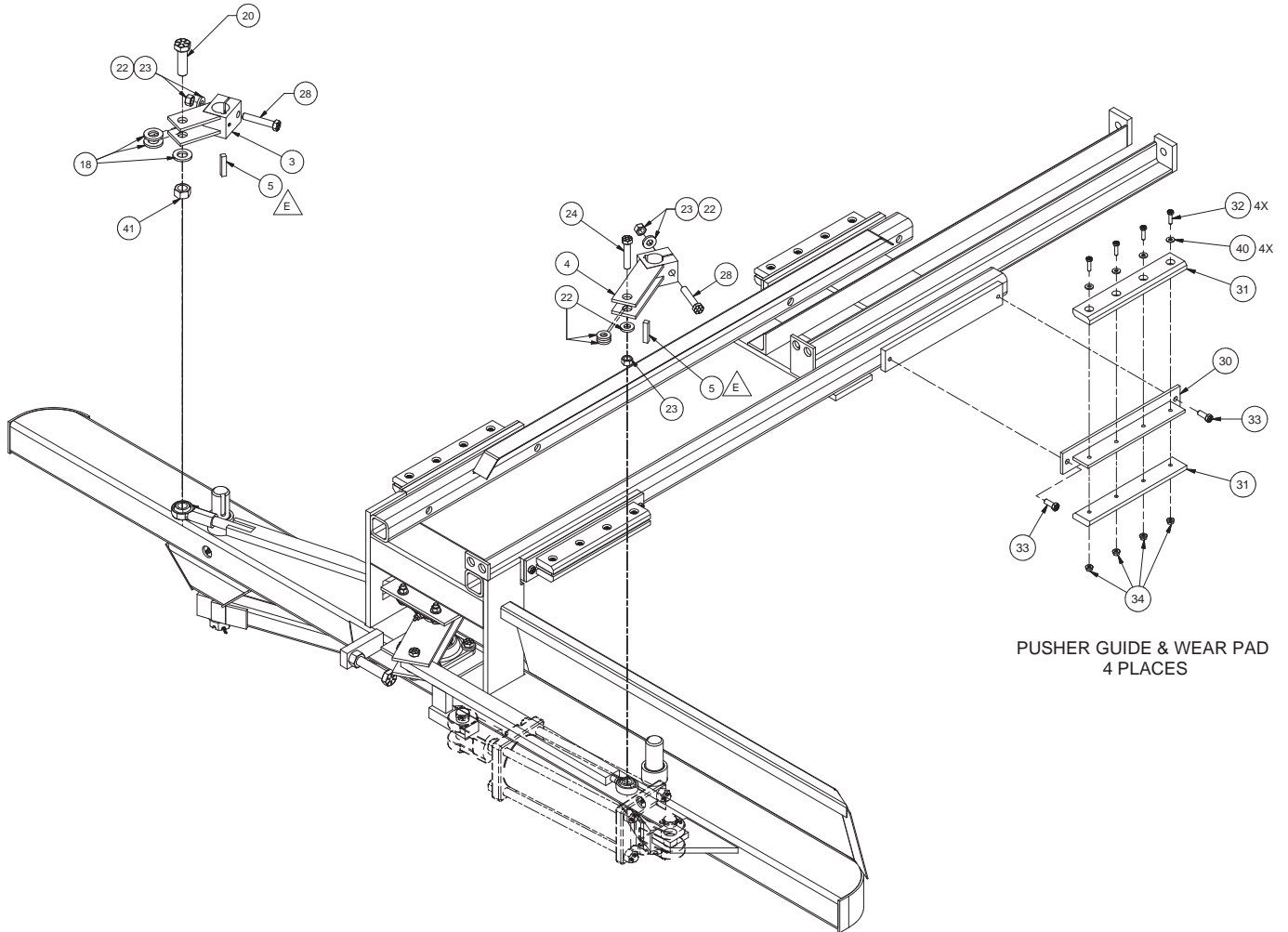

Bale Retainer Installation

Page 1 of 2

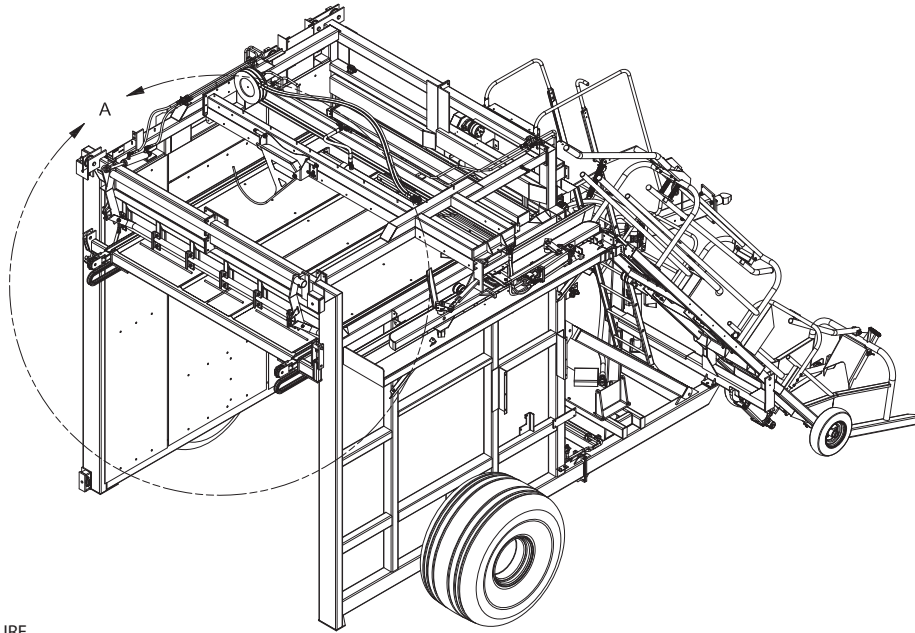

USE AS REQUIRED TO ENSURE
BALE RETAINER BAR (ITEM 1)
SWINGS FREELY.

4 PLC'S

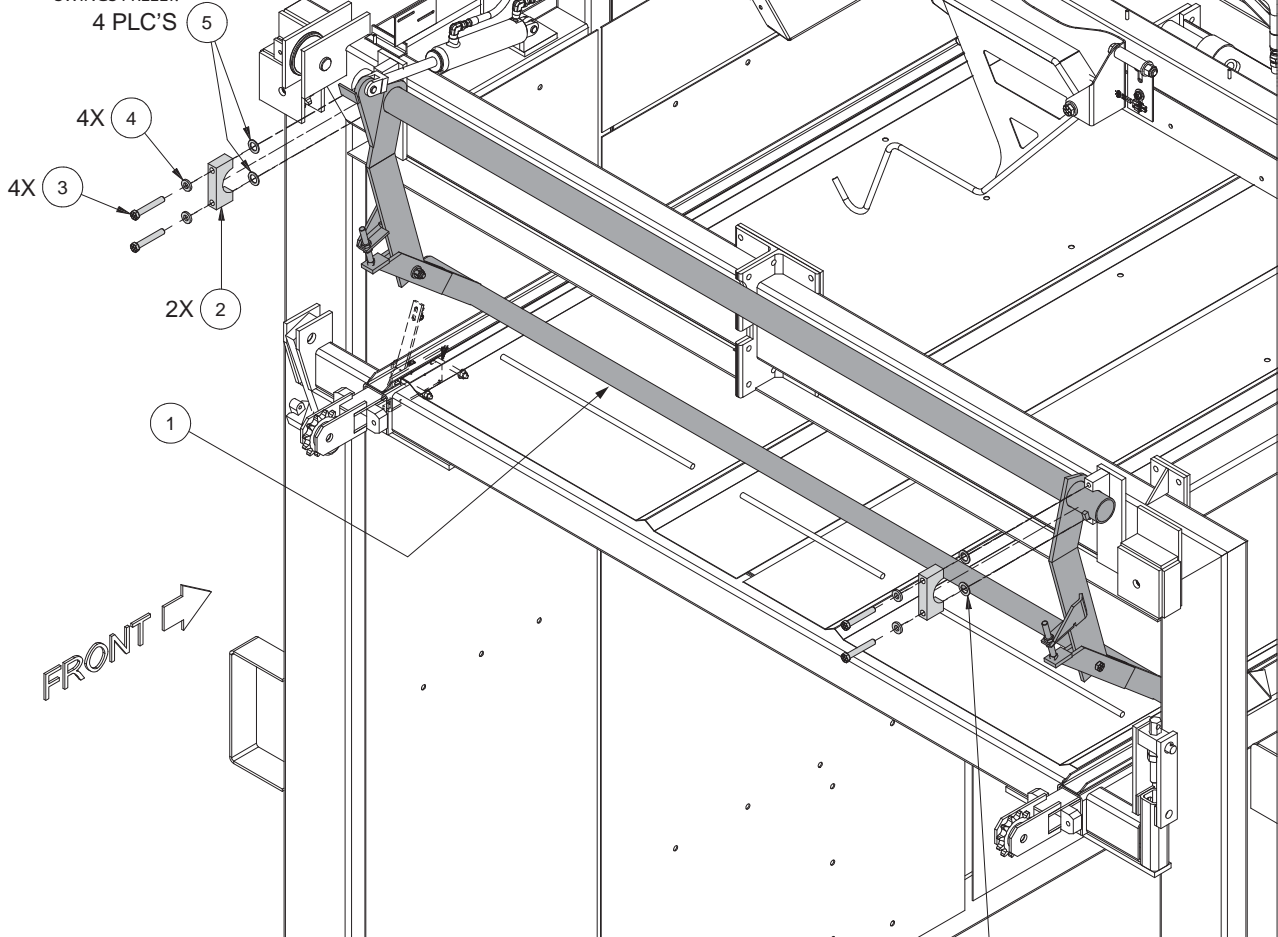

DETAIL A

5

Bale Retainer Installation

Page 2 of 2

Item	Part No.	Qty	Description	Item	Part No.	Qty	Description
	906665		Bale Retainer Installation				
1	* 902424	1	. Bale Retainer Assembly (Page 63)	4	221771W	4	. Washer
2	MNT0025269	2	. Bar, Retain	5	ZZ00000206	4	. Mach Bushing
3	R13811082	4	. Capscrew				

* See Separate Coverage

Rev -

Bale Retainer Assembly

Page 1 of 2

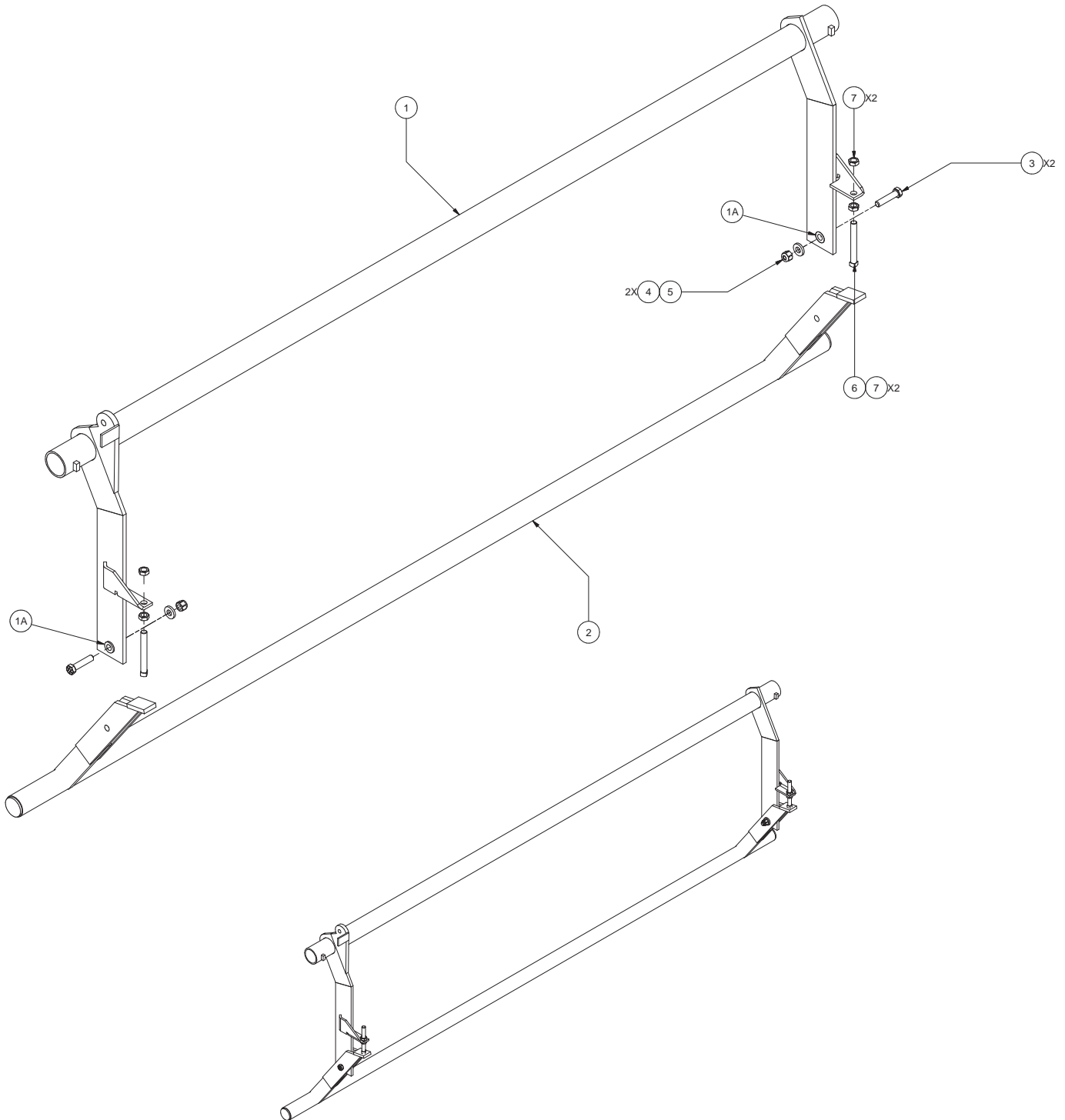

Bale Retainer Assembly

Page 2 of 2

Item	Part No.	Qty	Description	Item	Part No.	Qty	Description
	902424		Bale Retainer Assembly				
1	RET0016912	1	. Upper Bale Retainer	5	223587	2	. Nut, Esna
1A	DRW0032639	2	. . Bushing	6	SQS5004500	2	. Set Screw
2	RET0016913	1	. Retainer, Lower	7	234218	6	. Jam Nut
3	221574W	2	. Capscrew				
4	221771W	2	. Washer				

Rev B

Panel Assembly

Page 1 of 2

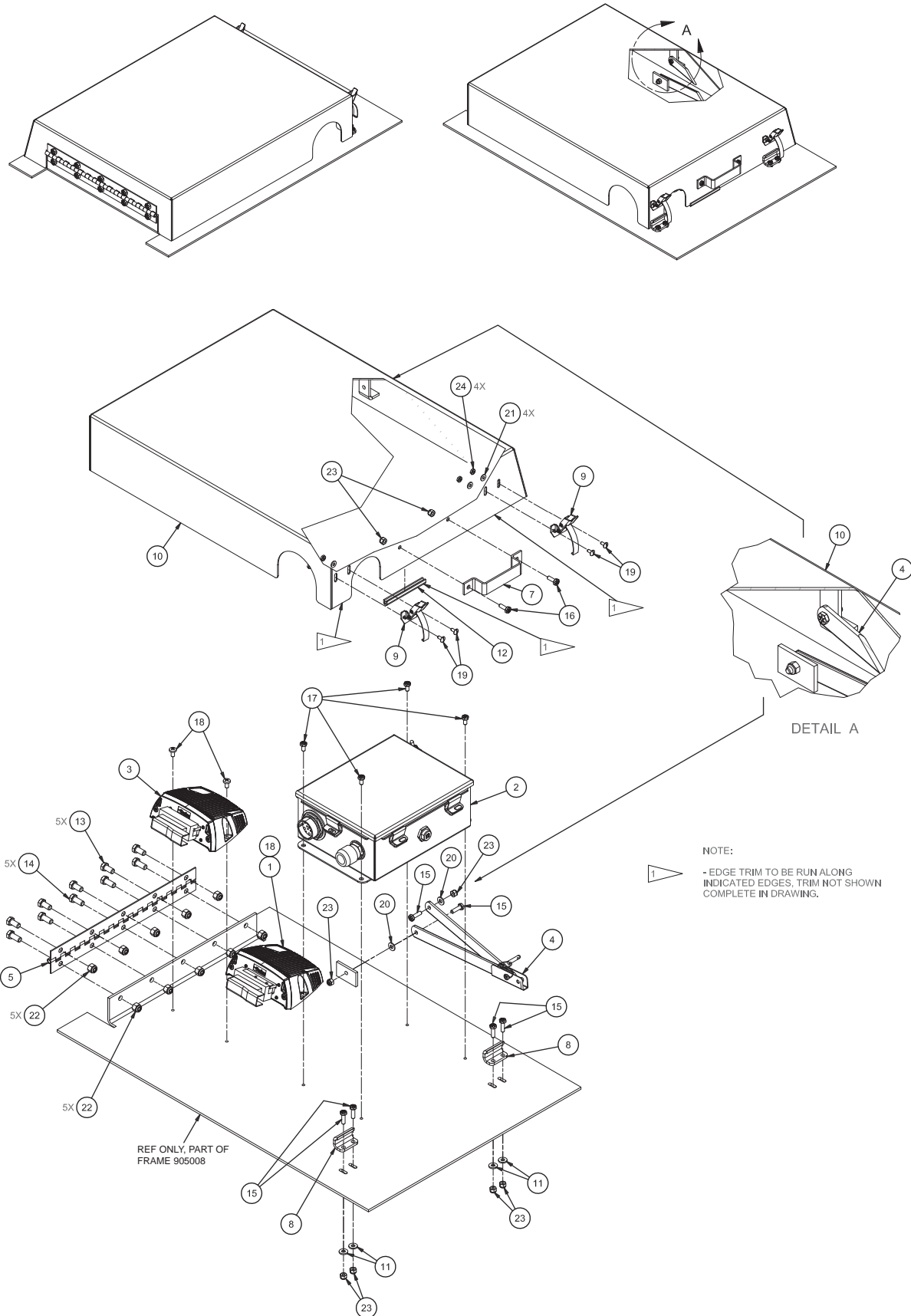

Panel Assembly

Page 2 of 2

Item	Part No.	Qty	Description	Item	Part No.	Qty	Description
	904996		Panel Assembly				
1	254837	1	. Module, Expansion	13	162572W	5	. Capscrew
2	* 904962	1	. Junction Box Assembly (Page 67)	14	R13811034	5	. Capscrew
3	905020	1	. Controller Assembly	15	R13810992	6	. Capscrew
4	257830	1	. Lid Support	16	224120W	2	. Capscrew
5	904999	1	. Hinge	17	R13810989	4	. Capscrew
7	HAN0017239	1	. Bar, Handle	18	00113955	4	. Machine Screw
8	905050	2	. Bracket, Mounting	19	SMR1000500	4	. Machine Screw
9	CLP0000130	2	. Fastener, Hook Type	20	R13811443	2	. Flat Washer
10	905049	1	. Mount	21	00103338	4	. Flat Washer
11	221763W	4	. Washer	22	237567	10	. Nut, Esna
12	MLD7500317	2'	. Trim, Edge	23	235620	8	. Nut, Esna
				24	R13812544	4	. Hex Nut

* See Separate Page

Rev A

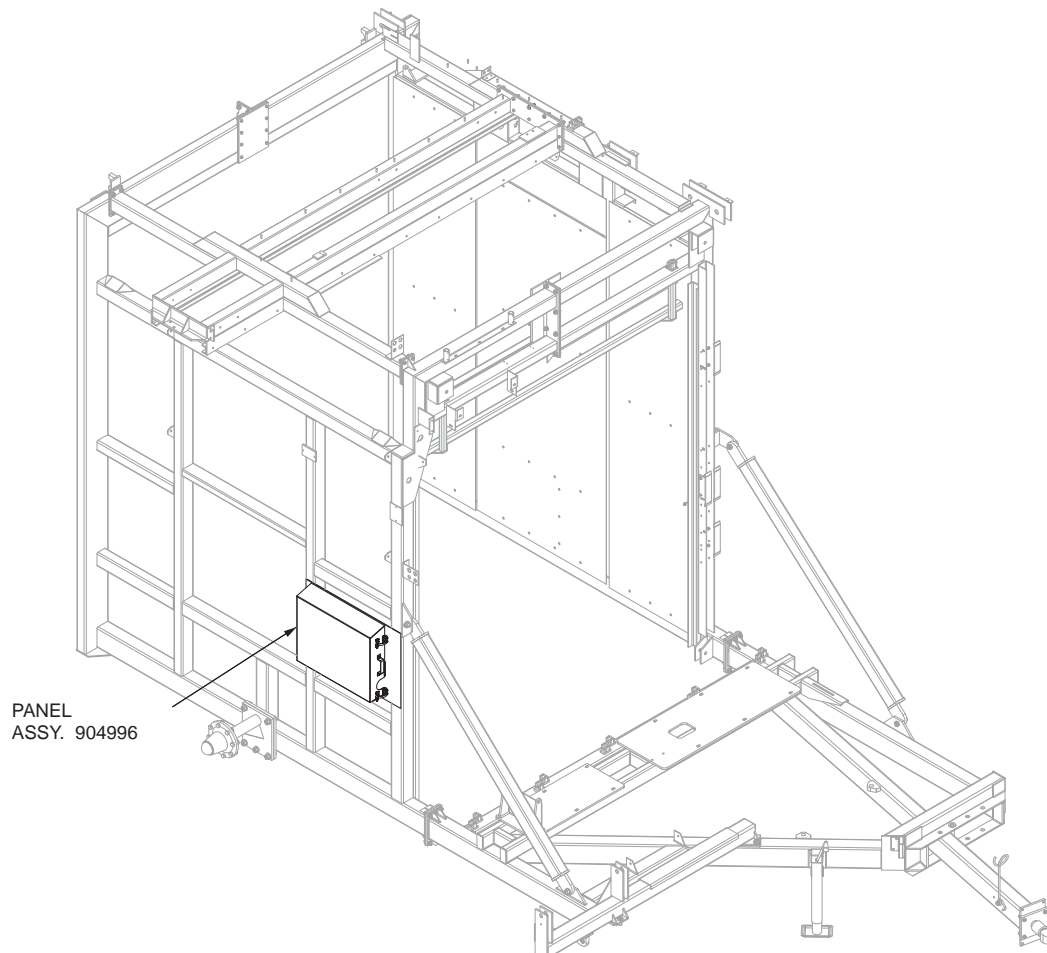

Electrical Junction Box Assembly

Page 1 of 2

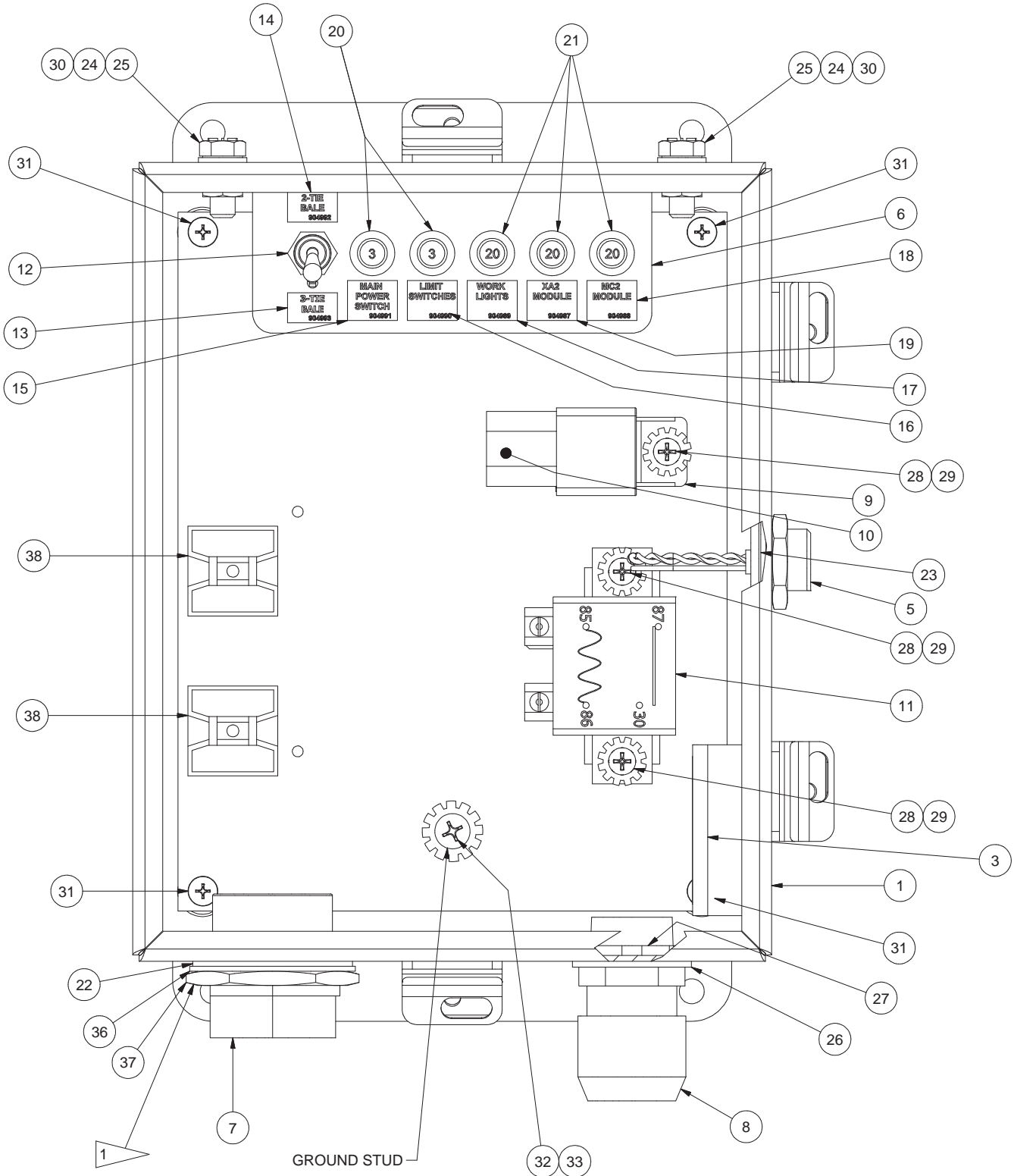

1 - TORQUE NUT TO 350 - 375 IN-LBS. (29 - 31 FT-LBS.)

JUNCTION BOX ASSEMBLY
(SHOWN WITHOUT DOOR)

Electrical Junction Box Assembly

Page 2 of 2

Item	Part No.	Qty	Description	Item	Part No.	Qty	Description
	904962		Junction Box Assembly				
1	904964	1	. Box	19	904987	1	. Decal
2	904965	1	. Panel	20	223063	2	. Circuit Breaker
3	20294	1PK	. Oxidation Inhibitor	21	223377	3	. Circuit Breaker
4	* 904981	1	. Wire Harness, Junction Box	22	906205	1	. Seal
5	255240	1	. Adapter, USB	23	230471	1	. Seal
6	904968	1	. Plate, Mounting	24	214479	2	. Seal
7	258858	1	. Receptacle	25	R13801791	2	. Capscrew
8	230839	1	. Connector, Cord	26	231044	1	. Ring, Seal
9	R4510197	1	. Relay, Work Lights	27	NMS0000109	1	. Conduit Locknut
10	246143	1	. Relay Socket	28	102X050PFM	3	. Machine Screw
11	252619	1	. Relay, Main Power	29	R13809575	3	. Lockwasher
12	229289	1	. Toggle Switch	30	00273802	2	. Nut, Serrated
13	904993	1	. Decal	31	103X037PPM	4	. Machine Screw
14	904992	1	. Decal	32	00113957	1	. Machine Screw
15	904991	1	. Decal	33	223860	1	. Lockwasher
16	904990	1	. Decal	36	R740837	1	. Lockwasher
17	904989	1	. Decal	37	R740836	1	. Nut
18	904988	1	. Decal	38	220949	2	. Mount, Adhesive Back

* See Schematic Pack For Wire Harness Diagram

Rev B

Control Box Assembly

Page 1 of 2

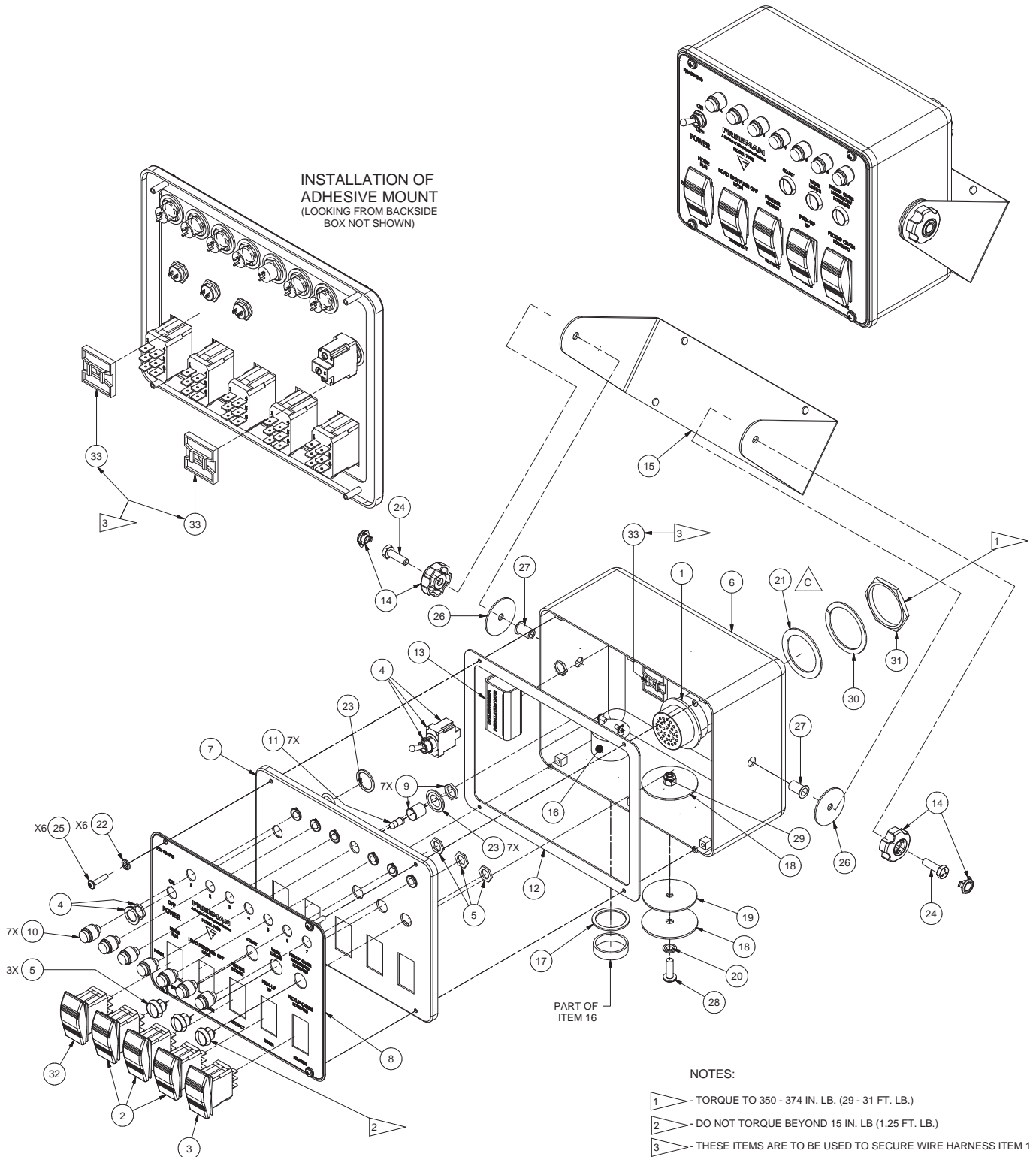

Control Box Assembly

Page 1 of 2

Item	Part No.	Qty	Description	Item	Part No.	Qty	Description
904940 Control Box Assembly							
1	* 904951	1	. Wire Harness, Control Box	19	904954	1	. Gasket
2	SWI0000007	3	. Switch, Rocker	20	12723	1	. Seal
3	SWI0000008	1	. Switch, Rocker	21	220353	1	. Seal
4	229289	1	. Toggle Switch	22	258821	4	. Seal
5	SWI0000004	3	. Switch, Push Button	23	207563	8	. Seal
6	904937	1	. Box, Control	24	18462W	2	. Capscrew
7	904938	1	. Cover	25	234494	4	. Capscrew
8	904939	1	. Decal	26	WAS5613062	2	. Washer
9	03-188	7	. Indicator Lamp Base	27	222470	2	. Nut, Insert
10	03-189	7	. Indicator Lamp Lens	28	00113957	1	. Machine Screw
11	03-190	7	. Indicator Lamp Bulb	29	R13811189	1	. Locknut
12	904936	1	. Gasket	30	R740837	1	. Lockwasher
13	** 20294	1PK	. Oxidation Inhibitor	31	R740836	1	. Nut
14	KOB0000102	2	. Knob	32	253095	1	. Switch, Rocker
15	901276	1	. Bracket, Mounting	33	220949	3	. Mount, Adhesive Back
16	258826	1	. Buzzer				
17	258827	1	. Gasket	* See Schematic Pack For Wire Harness Diagram			
18	904953	2	. Plate, Cover	** Should Be Replaced Every Two (2) Years			

Rev D

Manifold & Tank Installation

Page 1 of 4

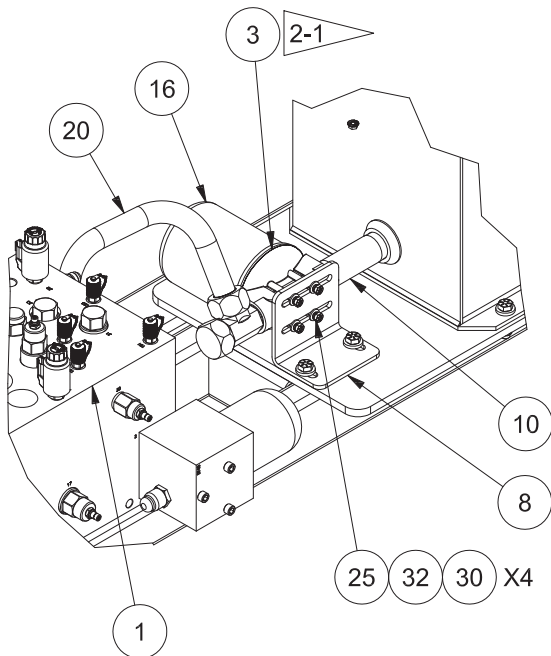
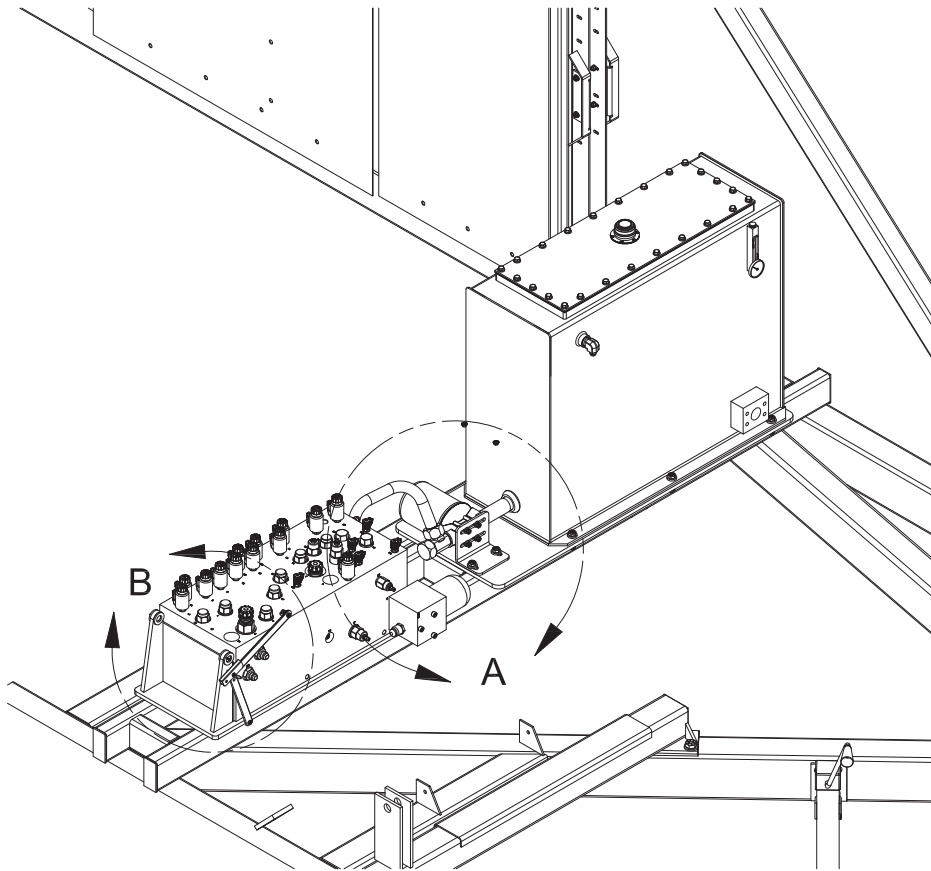

DETAIL A

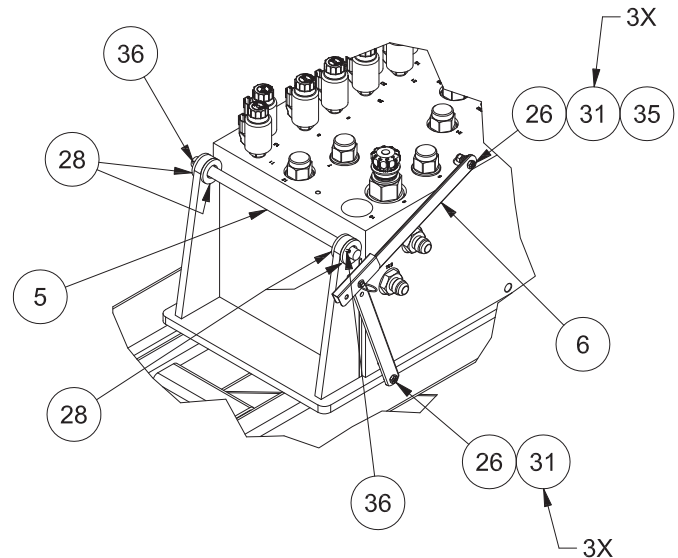

DETAIL B

NOTE:

2-1 - FILTER HEAD FLOW ARROW SHOULD POINT TOWARD RESERVOIR.

Manifold & Tank Installation

Page 2 of 4

Item	Part No.	Qty	Description	Item	Part No.	Qty	Description
906561 Manifold & Tank Installation							
1	* 906565	1	. Manifold Assembly (Page 75)	20	905103	1	. Tube Assembly
2	* 906559	1	. Tank Assembly, Hydraulic (Page 79)	21	R13811077	6	. Capscrew
3	257810	1	. Head, Filter	22	221569W	6	. Capscrew
4	904980	1	. Cover, Manifold	23	R13811072	2	. Capscrew
5	905007	1	. Bar	25	R13811015	4	. Capscrew
6	257830	1	. Lid Support	26	R13810993	2	. Capscrew
7	HAN0017239	1	. Bar, Handle	27	R13810990	2	. Capscrew
8	904974	1	. Bracket, Mounting	28	221777W	4	. Washer
9	VLV0002005	1	. Ball Valve	29	221771W	20	. Washer
10	PPE1250401	1	. Nipple	30	R13802914	4	. Hard Washer
11	01-720	1	. Nipple, Pipe	31	221763W	6	. Washer
12	222852	1	. Fitting	32	Y22E-05	4	. Washer, Lock
13	210732	1	. Fitting	33	R13811193	6	. Locknut
14	211563	1	. Fitting	35	R13811189	1	. Locknut
15	217647	1	. Fitting	36	00103385	2	. Cotter Pin
16	FIL0023018	1	. Element, Filter	37	264150W	2	. Nut
19	905100	1	. Sensor, Temp				

* See Separate Page

Rev C

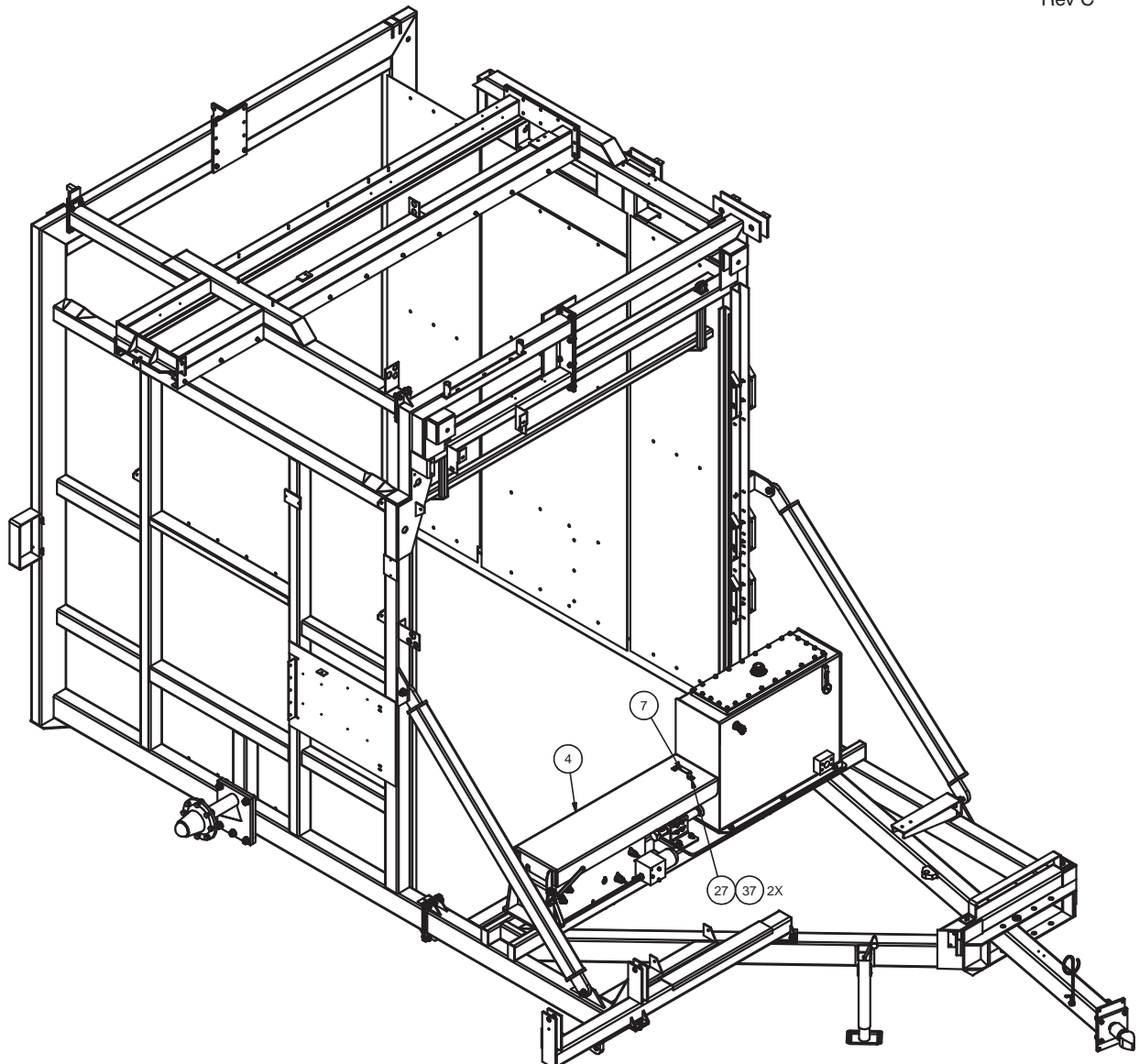

Manifold & Tank Installation

Page 3 of 4

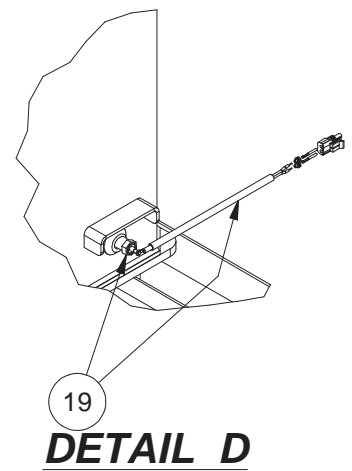
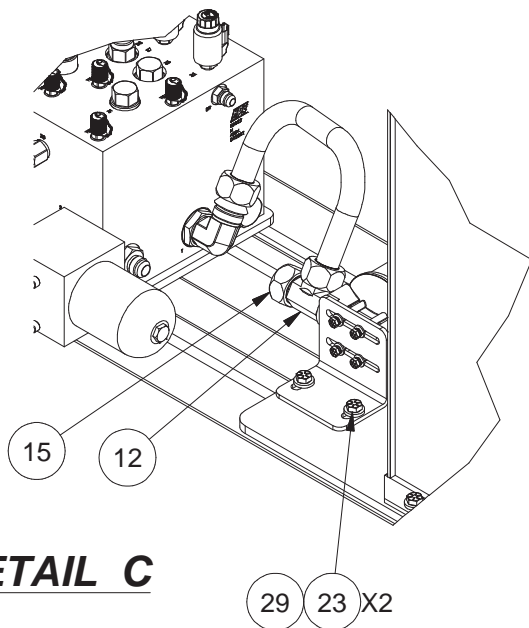
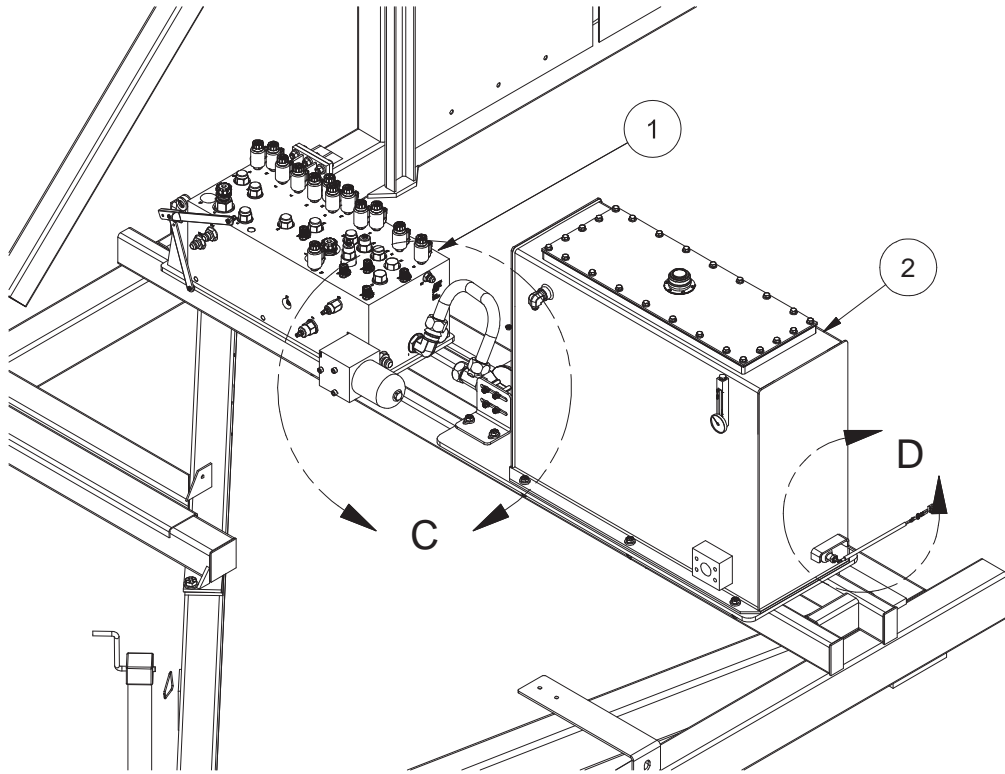

Manifold & Tank Installation

Page 4 of 4

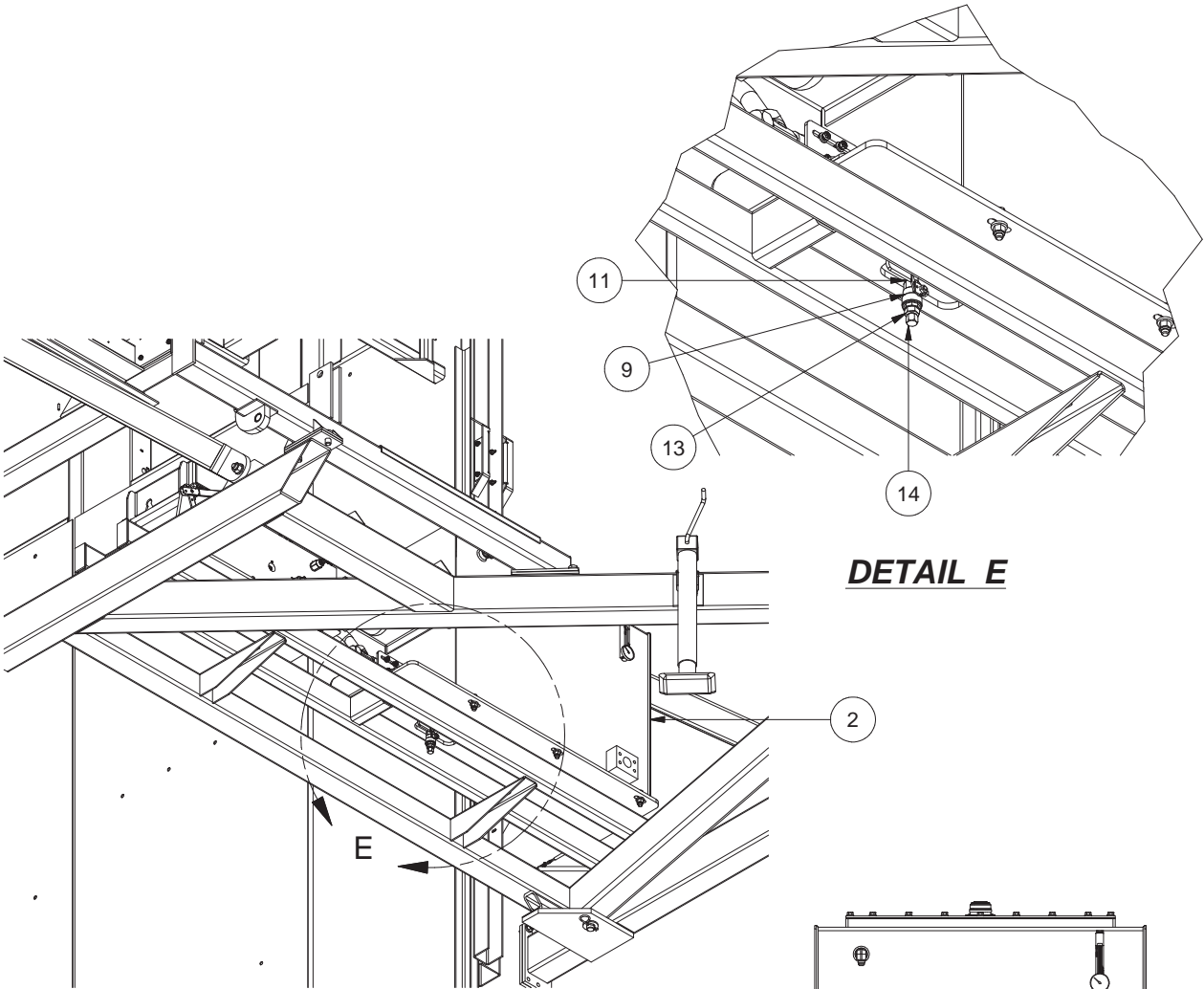

DETAIL E

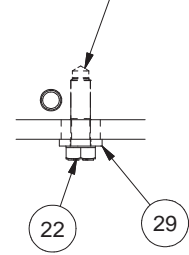
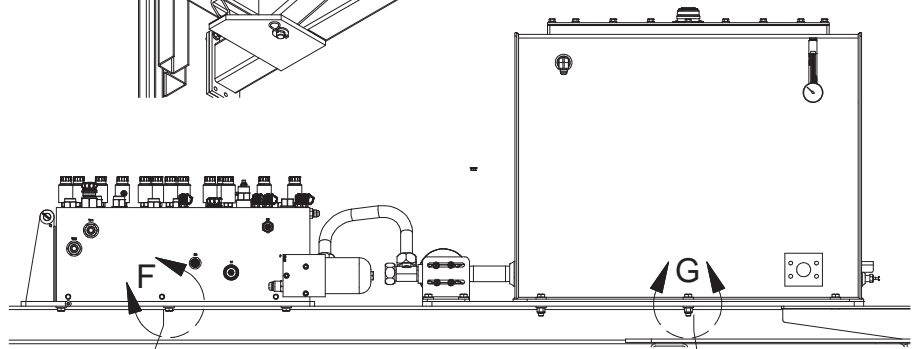

DETAIL F
6 PLACES

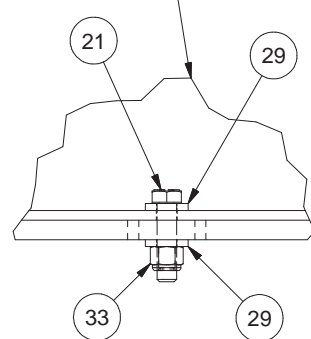

DETAIL G
6 PLACES

Hydraulic Manifold Assembly

Page 1 of 2

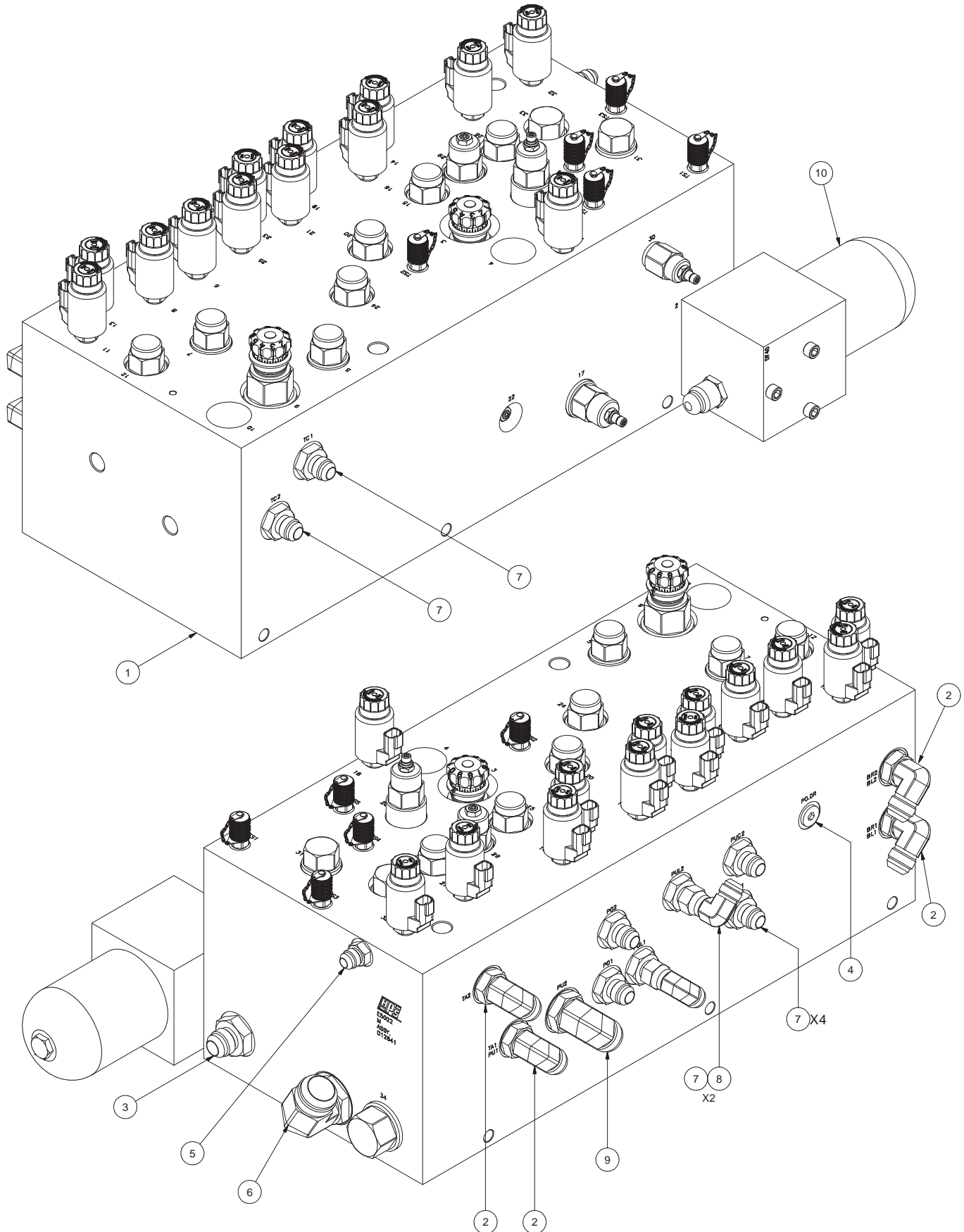

Hydraulic Manifold Assembly

Page 2 of 2

Item	Part No.	Qty	Description	Item	Part No.	Qty	Description
	906565		Manifold Assembly				
1	* 906564	1	. Manifold (Page 77)	7	209208	8	. Fitting
2	209490	4	. Fitting	8	209155	2	. Fitting
3	209164	1	. Fitting	9	209715	1	. Fitting
4	229345	1	. Fitting	10	259244	1	. Filter Assy
5	209805	1	. Fitting	10A	905168	1	.. Indicator
6	209714	1	. Fitting	10B	905169	1	.. Filter Element

* See Separate Page

Rev B

Hydraulic Manifold

Page 1 of 2

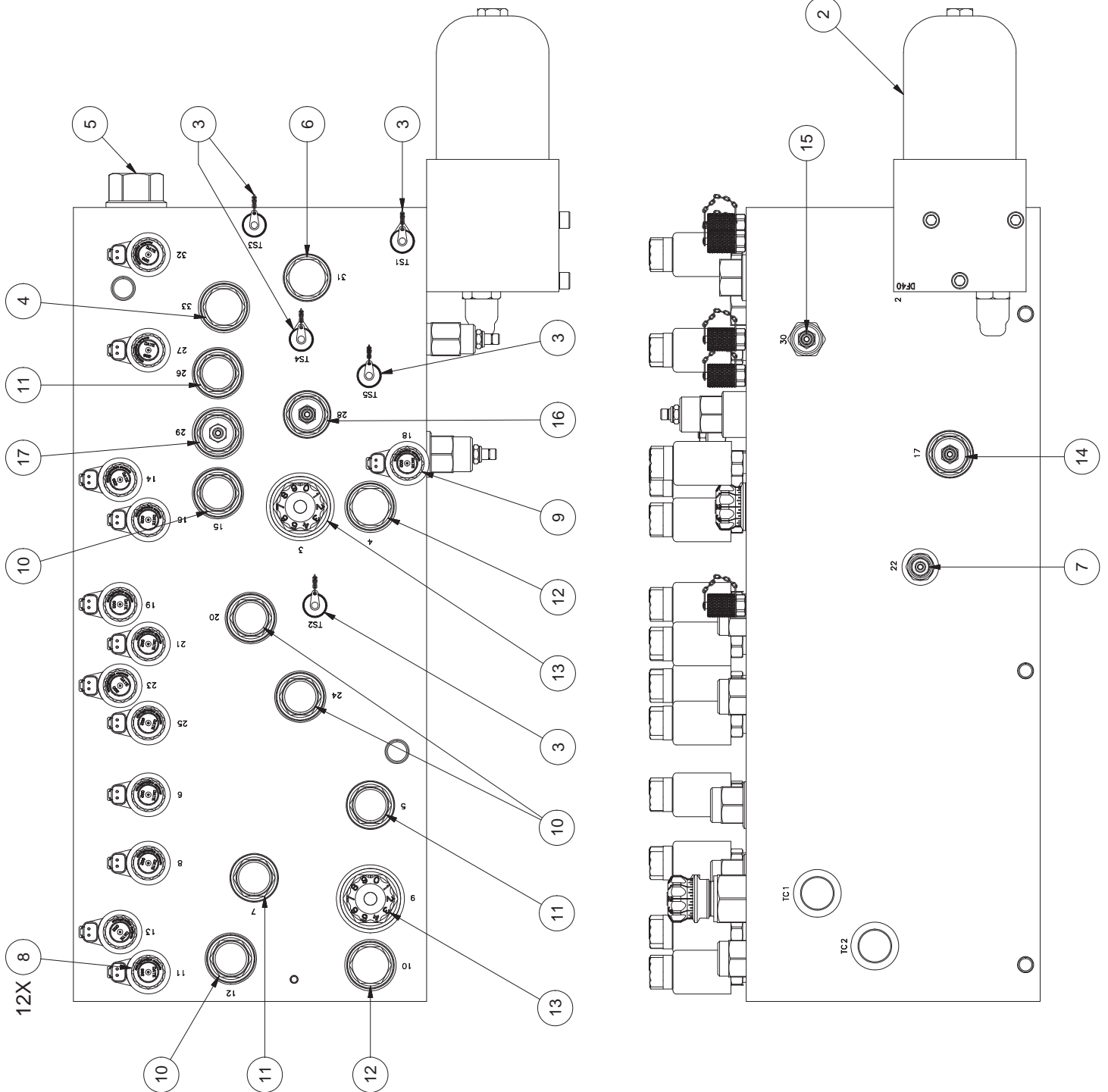

Hydraulic Manifold

Page 2 of 2

Item	Part No.	Qty	Description	Item	Part No.	Qty	Description
	906564		Hydraulic Manifold				
1	906587	1	. Manifold Block	10	*a 253243	4	. Valve, Dir Ctrl; 4-Way/3-Position
2	259244	1	. Filter Assy		254706	1	.. Seal Kit, Buna N.
2A	905168	1	.. Indicator		259259	1	.. Seal Kit, Viton
2B	905169	1	.. Filter Element	11	*a 259248	3	. Valve, Dir Ctrl; 4-Way, 2-Position
3	259274	5	. Test Point		254706	1	.. Cartridge Seal Kit, Viton
4	*a 259256	1	. Valve, Check; 3-Port, Non-Vented		259259	1	.. Coil Seal Kit, Viton
	243815	1	.. Seal Kit, Buna N.	12	*a 259247	2	. Cartridge; Normally Closed
	R12973037	1	.. Seal Kit, Viton		251394	1	.. Cartridge Seal Kit, Viton
5	*b 259257	1	. Valve, Check; 2-Port, Free Flow		236134	1	.. Coil Seal Kit, Viton
	251394	1	.. Seal Kit, Buna N.	13	*c 259246	2	. Valve, Needle; 2-Port, Direct Acting
	236133	1	.. Seal Kit, Viton		251394	1	.. Cartridge Seal Kit, Viton
6	*a 259255	1	. Valve, Check; 3-Port, 1.8:1 Ratio		236133	1	.. Coil Seal Kit, Viton
	243815	1	.. Seal Kit, Buna N.	14	*a,g 259250	1	. Valve, Relief; 3-Port, W/Pilot Assist
	R12973037	1	.. Seal Kit, Viton		259260	1	.. Cartridge Seal Kit, Viton
7	*c 259252	1	. Valve, C/B; 3-Port, W/Pilot Assist		259261	1	.. Coil Seal Kit, Viton
	242101	1	.. Seal Kit, Buna N.	15	*e,g 244055	1	. Valve, C/B; 3-Port, W/Pilot Assist
	234655	1	.. Seal Kit, Viton		259258	1	.. Cartridge Seal Kit, Viton
8	259266	12	. Valve, Dir; 3-Way, 2-Position		255601	1	.. Coil Seal Kit, Viton
	*d 259267	1	.. Cartridge Seal Kit, Buna N.	16	*a,g 244001	1	. Valve, Sequence; Direct Acting
	*d 259269	1	.. Cartridge Seal Kit, Viton		243815	1	.. Cartridge Seal Kit, Viton
	*e 236133	1	.. Coil Seal Kit, Viton		R12973037	1	.. Coil Seal Kit, Viton
9	259275	1	. Valve, Dir; 2-Way, 2-Position	17	*a,g 906586	1	. Valve, C/Balance; 3:1 Pilot Ratio
	*d 259267	1	.. Cartridge Seal Kit, Buna N.		243815	1	.. Cartridge Seal Kit, Viton
	*d 259269	1	.. Cartridge Seal Kit, Viton		R12973037	1	.. Coil Seal Kit, Viton
	*f 236133	1	.. Coil Seal Kit, Viton				

*a Installation Torque = 150-160 lb*ft

*b Installation Torque = 350-375 lb*ft

*c Installation Torque = 80-90 lb*ft

*d Installation Torque = 20-25 lb*ft

*e Installation Torque = 40-50 lb*ft

*f Adjustment Torque = 4.5 in*lb

*g Adjustment Torque = 80-90 in*lb

Rev B

Hydraulic Tank Assembly

Page 1 of 2

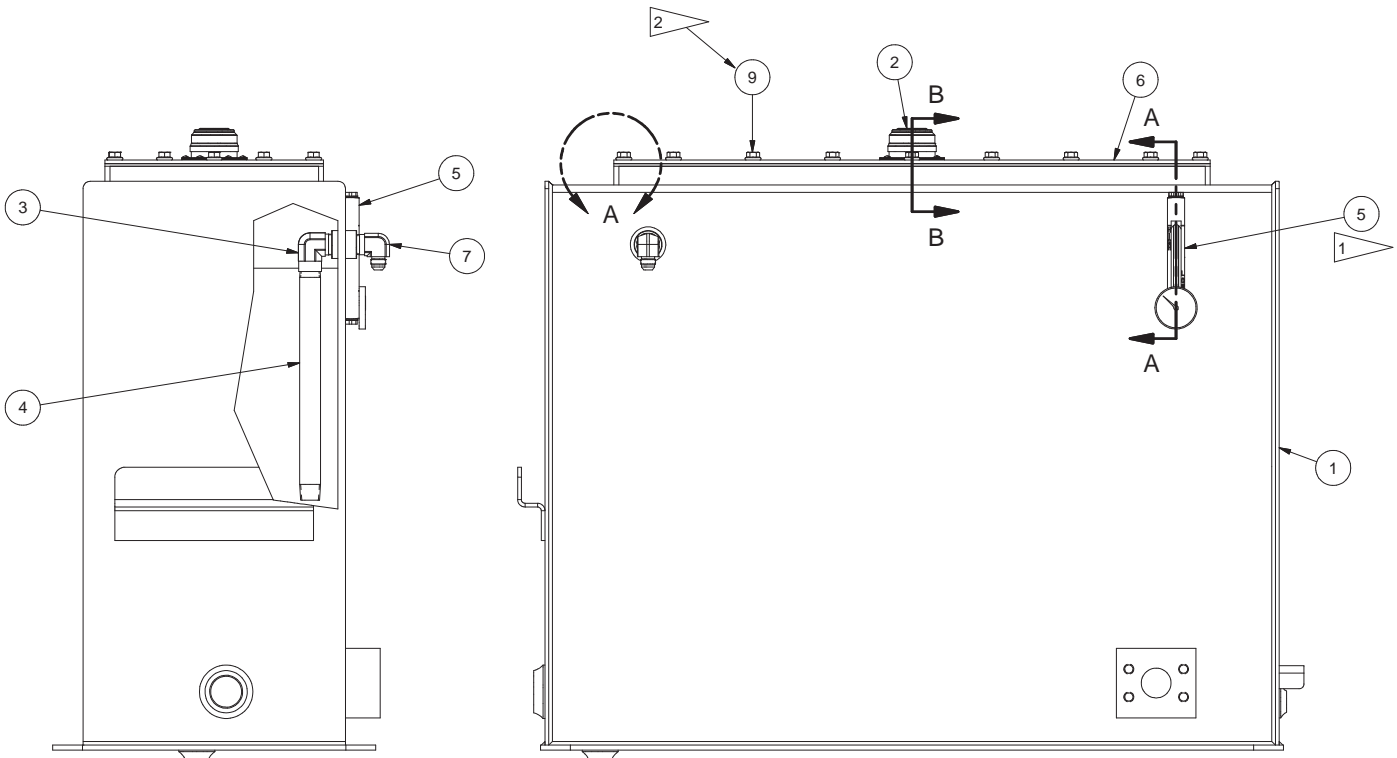
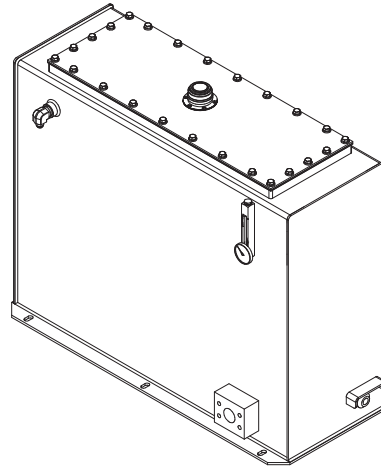

NOTES:

1. TORQUE NUTS QTY (2)
TO 60 IN-LBS.
2. TORQUE BOLTS QTY (24)
TO 28 FT-LBS.
3. SEAL ALL PIPE THREADS
WITH LOCTITE 567.
4. GASKET SUPPLIED WITH ITEM 2.
MOUNT GASKETS AS SHOWN.
6. TANK DESIGN CAPACITY AT FILL
LEVEL WHICH IS AT THE CENTER
OF THE SIGHT GAUGE IS 48 GALLONS U.S.
(181 LITRES).

Hydraulic Tank Assembly

Page 2 of 2

Item	Part No.	Qty	Description	Item	Part No.	Qty	Description
	906559		Tank Assembly, Hydraulic				
1	906555	1	. Tank, Hydraulic	6	906557	1	. Cover Plate
2	FIL0010003	1	. Cap, Filter	7	225660	1	. Fitting
3	209181	1	. Fitting	8	906560	1	. Gasket, Cover
4	905132	1	. Nipple, Pipe	9	134803W	24	. Screw
5	GAG0064051	1	. Gauge, Sight Level				

Rev -

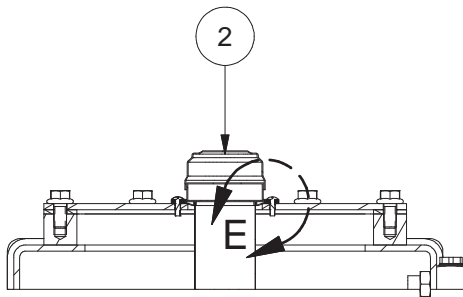

SECTION B-B

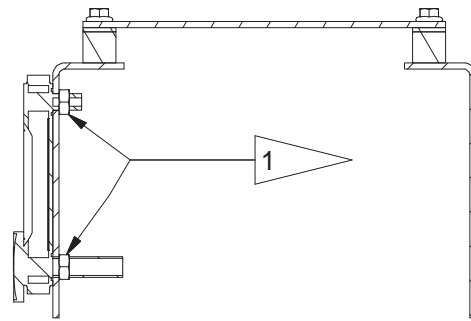

SECTION A-A

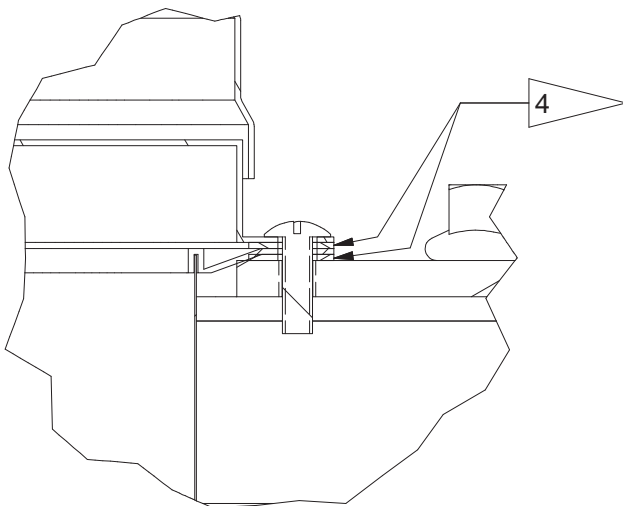

DETAIL E

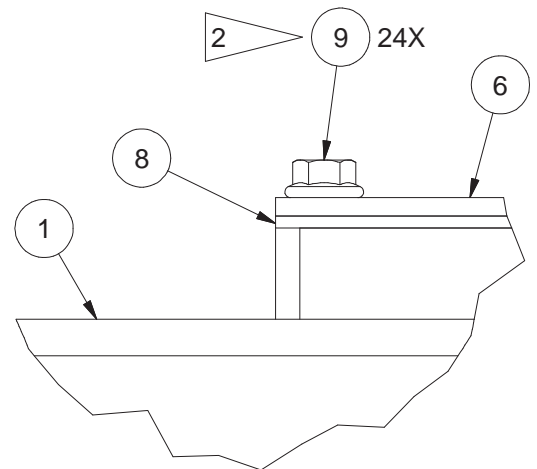

DETAIL A

Cylinder Installation

Page 1 of 4

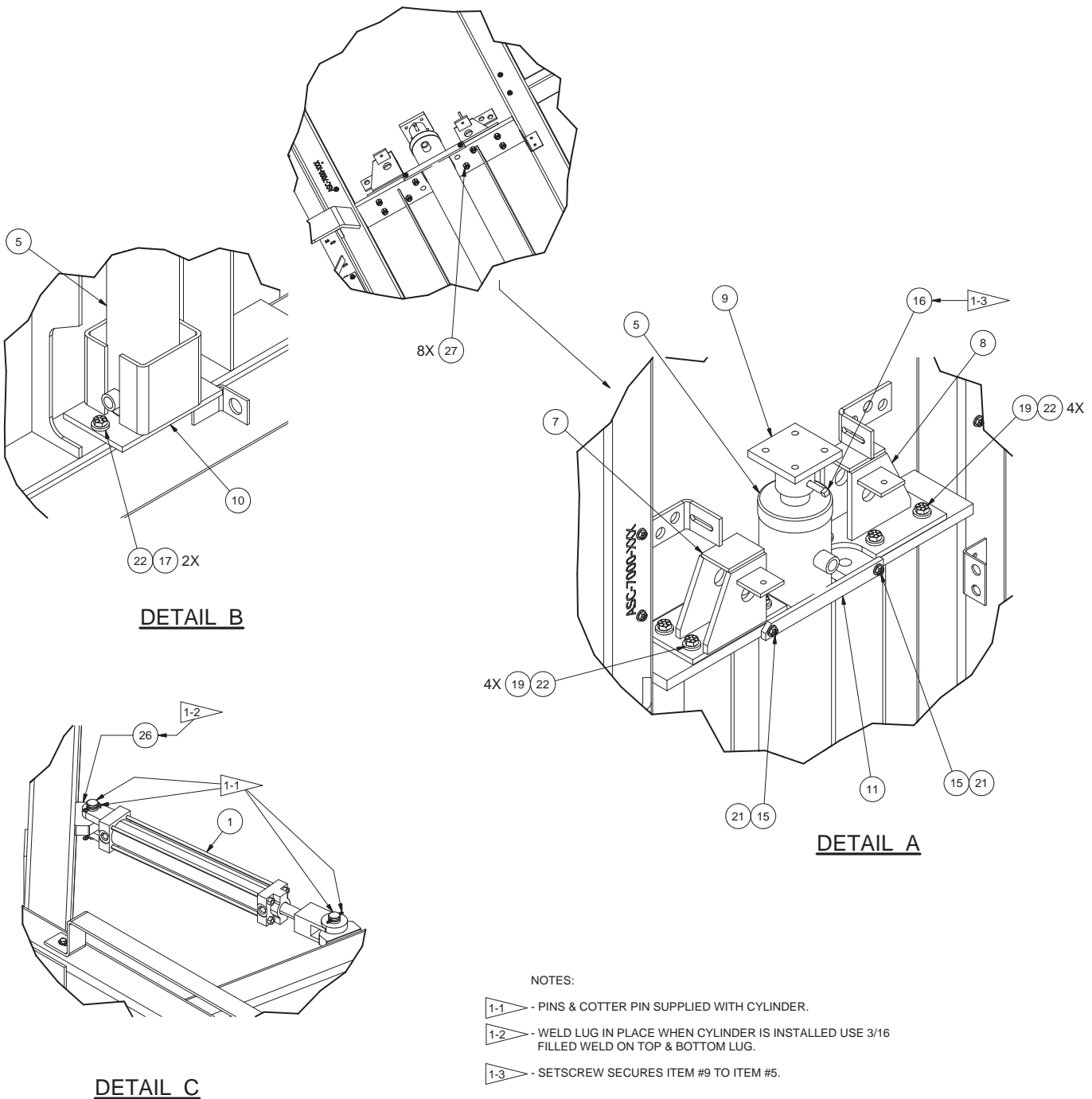

Cylinder Installation

Page 2 of 4

Item	Part No.	Qty	Description	Item	Part No.	Qty	Description
906677 Cylinder Installation							
1	CYL0009014	1	. Cylinder Assembly	12	LNK0073249	1	. Plate, Link
	258627	1	. . Seal Kit	13	PIN0011337	1	. Clevis Pin
2	CYL0017568	1	. Cylinder Assembly, Hydraulic	14	00103409	1	. Cotter Pin
	SELTC17568	1	. . Seal Kit	15	R13811014	2	. Capscrew
3	906538	1	. Cylinder Assembly, Hydraulic	16	SQS3751500	1	. Setscrew
	906943	1	. . Seal Kit	17	221563W	2	. Capscrew
4	F000006724	1	. Cylinder, Hydraulic	18	200454W	4	. Capscrew
	F000006727	1	. . Seal Kit	19	R13811077	8	. Capscrew
5	CYL0000454	1	. Cylinder Assembly, Hydraulic	20	221666W	1	. Capscrew
	SEL0000454	1	. . Seal Kit	21	R13802914	2	. Hard Washer
6	CYL0004966	1	. Cylinder Assembly, Hydraulic	22	221771W	14	. Washer
	SEL0310534	1	. . Seal Kit	23	R13806990	2	. Flat Washer
7	906674	1	. Chain Roller, LH Mnt	24	221711W	4	. Hex Nut
8	906675	1	. Chain Roller, RH Mnt	25	221716W	2	. Hex Nut
9	MNT0016865	1	. Cylinder Shaft Mount	26	DRW0032308	1	. Plate, Drawbar
10	MNT0016868	1	. Cylinder Base Mount	27	223587	8	. Nut, Esna
11	STR0073341	1	. Bar, Support				

Rev - A

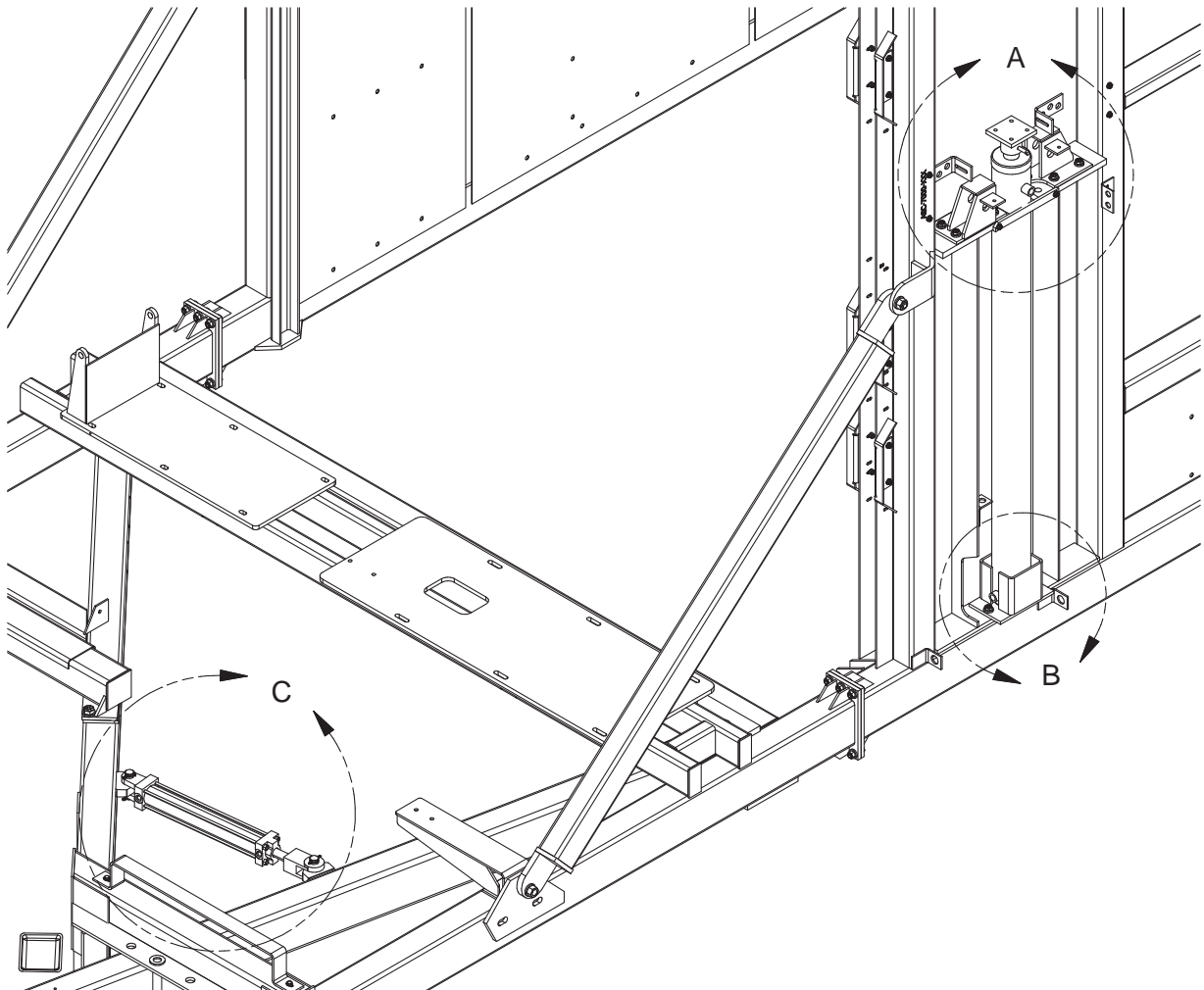

Cylinder Installation

Page 3 of 4

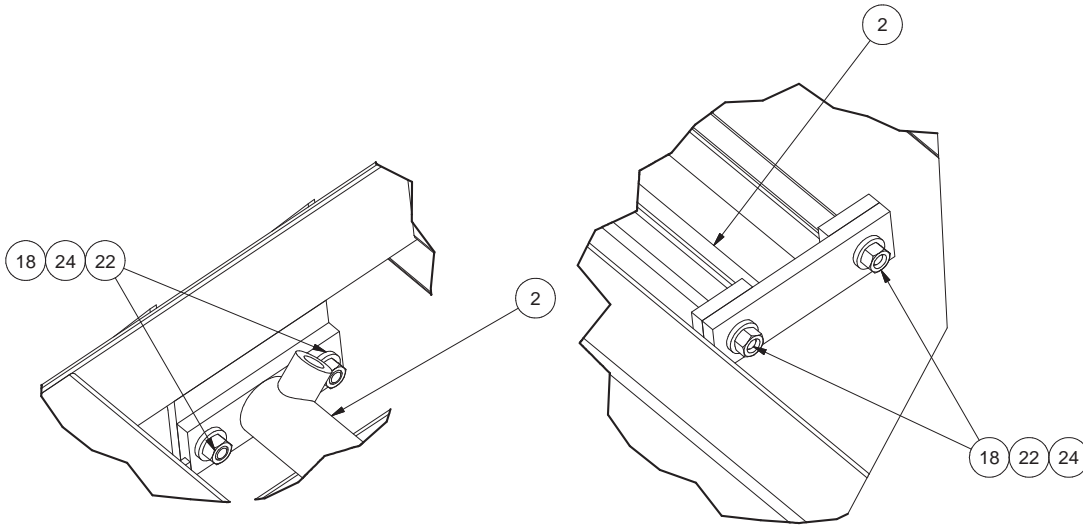

DETAIL F

DETAIL G

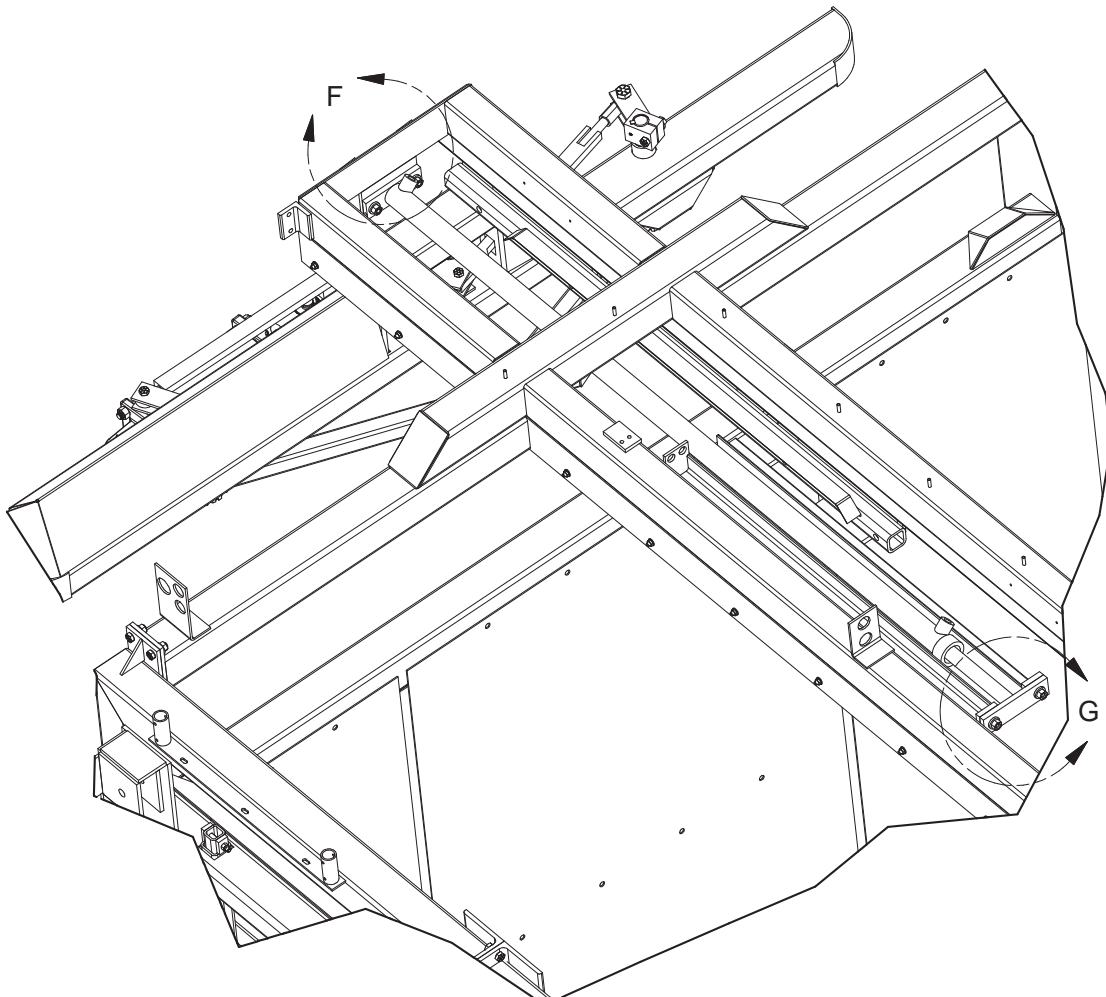

DETAIL E

Cylinder Installation

Page 4 of 4

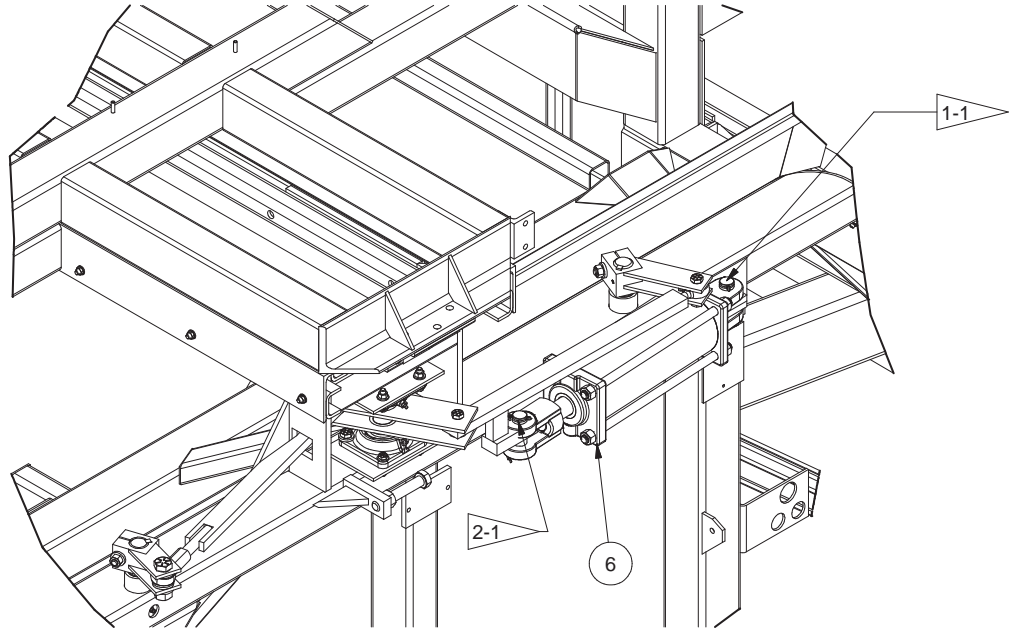

DETAIL D

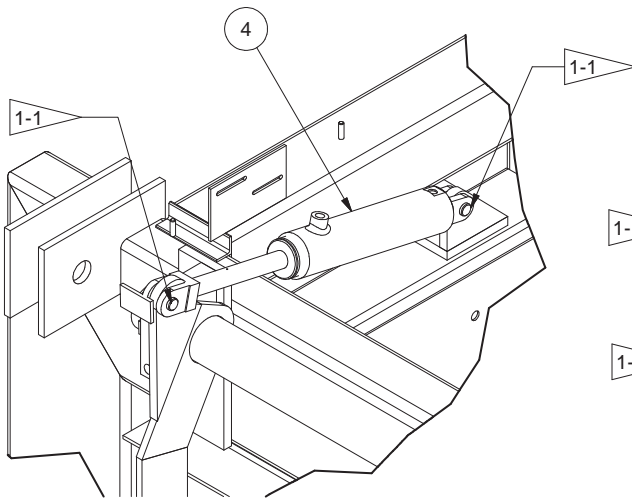

DETAIL H

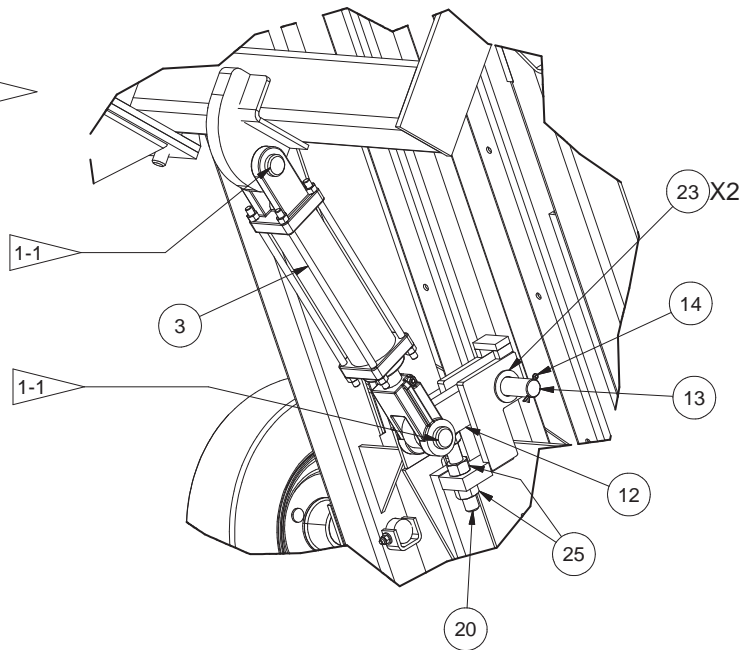

DETAIL J

Hydraulic Hose & Tube Installation

Page 1 of 8

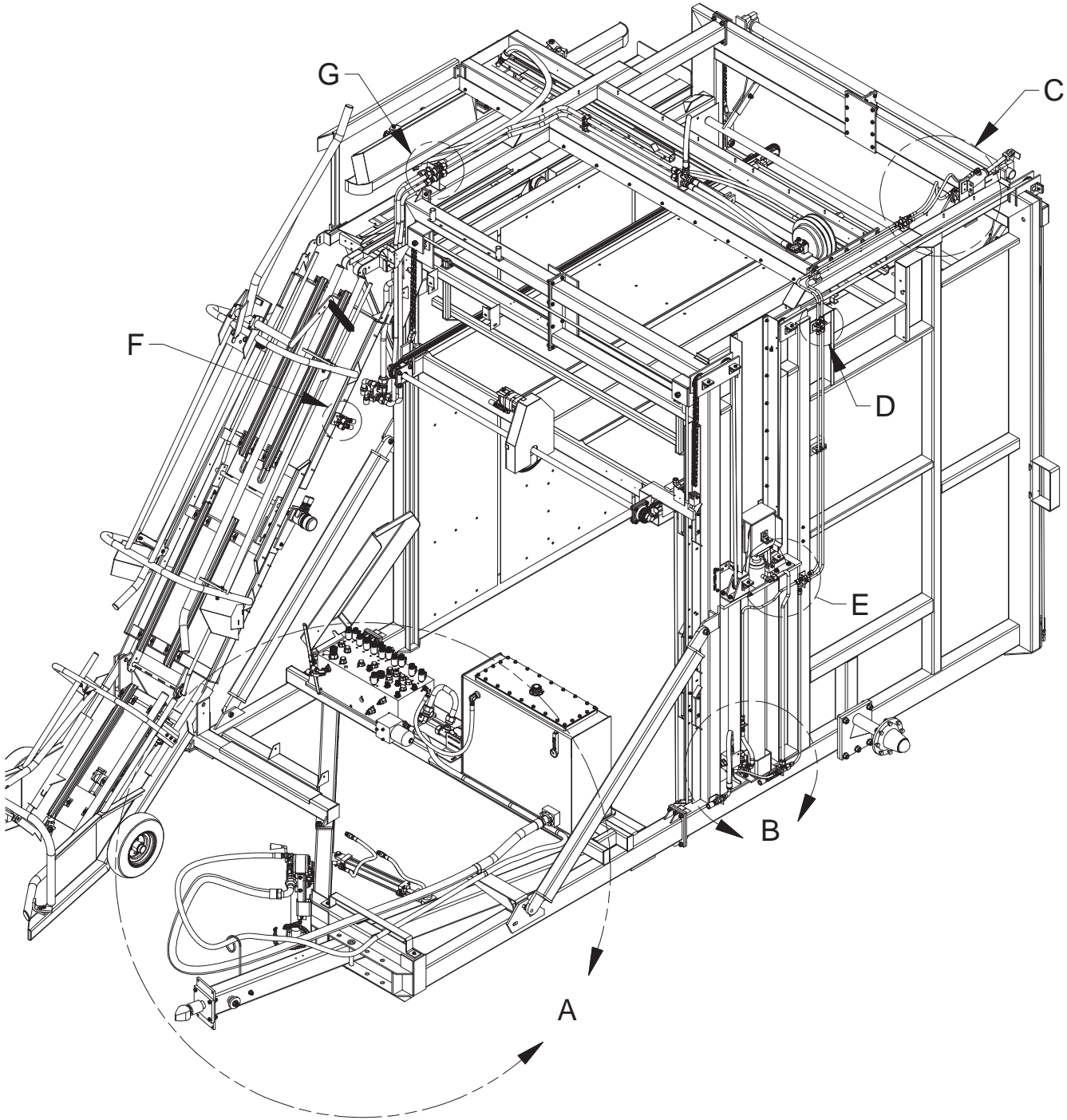

Hydraulic Hose & Tube Installation

Page 2 of 8

Item	Part No.	Qty	Description	Item	Part No.	Qty	Description
	906562		Hydraulic Instl, Hose & Tube				
1	209490	1	. Fitting	60	906596	2	. Hose Assembly
2	209414	1	. Fitting	61	259228	2	. Fitting, Cable Gland
3	209413	2	. Fitting	62	259222	1	. Hose Assembly
4	209411	1	. Fitting	63	259223	1	. Hose Assembly
5	209202	1	. Fitting	64	209325	1	. Hose Assembly
6	209758	2	. Fitting	65	215036	1	. Hose Assembly
7	HYD5435050	1	. Long Elbow	66	234230	1	. Hose Assembly
8	209155	1	. Fitting	67	906524	1	. Hose Assembly
9	14821	1	. Fitting	68	243356	1	. Hose Assembly
10	209416	1	. Fitting	69	906540	1	. Hose Assembly
11	209063	1	. Fitting	70	906539	1	. Hose Assembly
12	232934	2	. Fitting	71	906602	1	. Hose Assembly
13	HYD5924080	6	. Nut, Bulkhead	72	229641	1	. Hose Assembly
14	CPL0080104	2	. Coupler, Male	73	237822	1	. Hose Assembly
15	209409	1	. Fitting	74	244421	1	. Hose Assembly
16	11767	1	. Kit, Split Flange	75	906598	1	. Hose Assembly
17	220095	2	. Fitting	76	905158	1	. Fitting Assembly
18	14761W	11	. Nut, Bulkhead	77	905159	1	. Fitting Assembly
19	16980W	2	. Nut, O-Ring Fitting	78	905160	1	. Fitting Assembly
20	HYD5924050	2	. Nut, Bulkhead	80	TUB0035036	1	. Tube Assembly
21	217484	1	. Fitting	81	TUB0035037	1	. Tube Assembly
22	238011	2	. Fitting	82	TUB0035035	1	. Tube Assembly
23	209087	2	. Fitting	83	TUB0035010	1	. Tube Assembly
24	232862	1	. Fitting	84	TUB0035023	1	. Tube Assembly
25	R13807508	1	. Fitting	86	906593	1	. Tube Assembly
26	209488	1	. Fitting	87	TUB0035014	2	. Tube Assembly
28	215203	8	. Fitting	88	906609	1	. Hose Assembly
29	226904	2	. Fitting	89	906607	2	. Tube Assembly
30	210091	5	. Fitting	90	906604	1	. Tube Assembly
31	221231	1	. Fitting	92	906603	1	. Tube Assembly
32	HYD5525040	3	. Blkhd Union Elbow	94	906605	1	. Tube Assembly
33	23945	1	. Fitting	96	905149	1	. Tube Assembly
35	R12578057	1	. Fitting	112	* 906588	1	. Manifold Assembly (Page 93)
36	209805	2	. Fitting	113	HSP0000004	2	. Hose Protector
37	17949	1	. Fitting	114	209699	4	. Clamp
38	225830	2	. Fitting	115	209703	1	. Clamp
39	R13803393	1	. Fitting	116	221499W	3	. Capscrew
41	14763W	2	. Nut, Bulkhead	117	R13801850	2	. Capscrew
44	209166	1	. Fitting	118	221771W	2	. Washer
45	PMP0000001	1	. Pump, Hydraulic	119	237567	1	. Nut, Esna
	906167	1	. . Kit, Seal	120	047-0229	1	. Fitting
46	REE0646040	1	. Hose Reel	121	906687	1	. Hose Assembly
48	226552	1	. Fitting	122	BAR0073224	1	. Anchor Bar
50	241487	2	. Hose Assembly	123	223427	2	. Flat Washer
52	HOS0032754	1	. Hose Assembly	124	201567	2	. Lockwasher
53	HOS0032755	1	. Hose Assembly	125	257765	2	. Cushion, Clamp
54	HOS0032751	1	. Hose Assembly	126	247151	1	. Plate
55	HOS0029730	1	. Hose Assembly	127	257833	5	. Cover Plate
56	HOS0032756	2	. Hose Assembly	128	234867	2	. Capscrew
57	251960	1	. Hose Assembly	129	209151	1	. Fitting
58	259226	2	. Hose Assembly	130	906701	1	. Chain Assembly
59	259227	2	. Hose Assembly				

* See Separate Page

Rev D

Hydraulic Hose & Tube Installation

Page 3 of 8

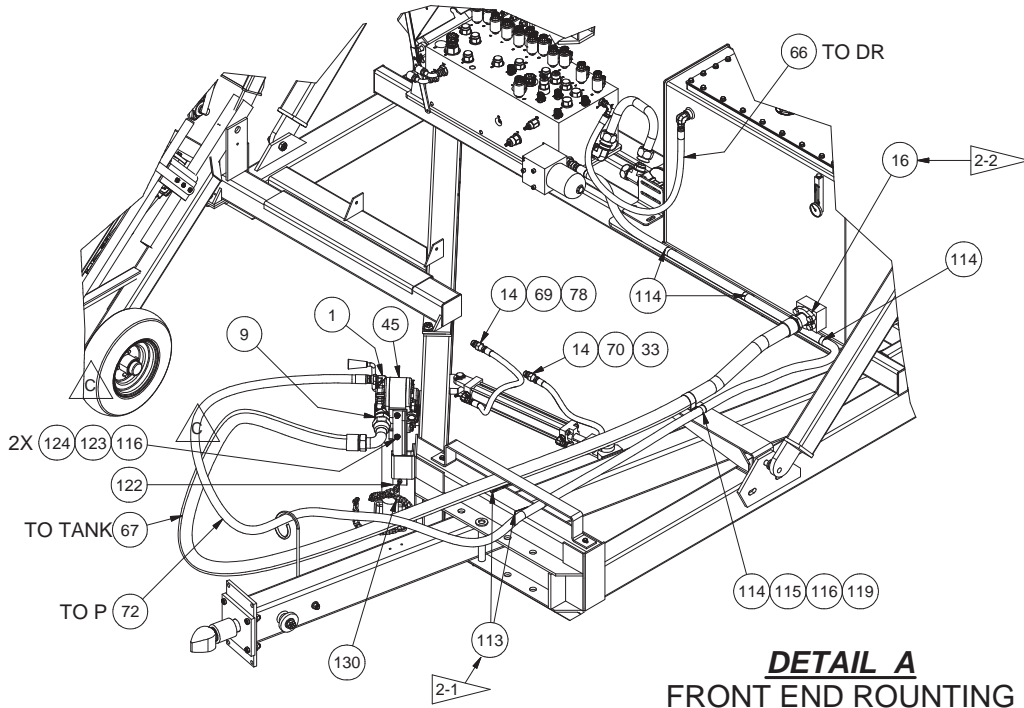

DETAIL A
FRONT END ROUTING

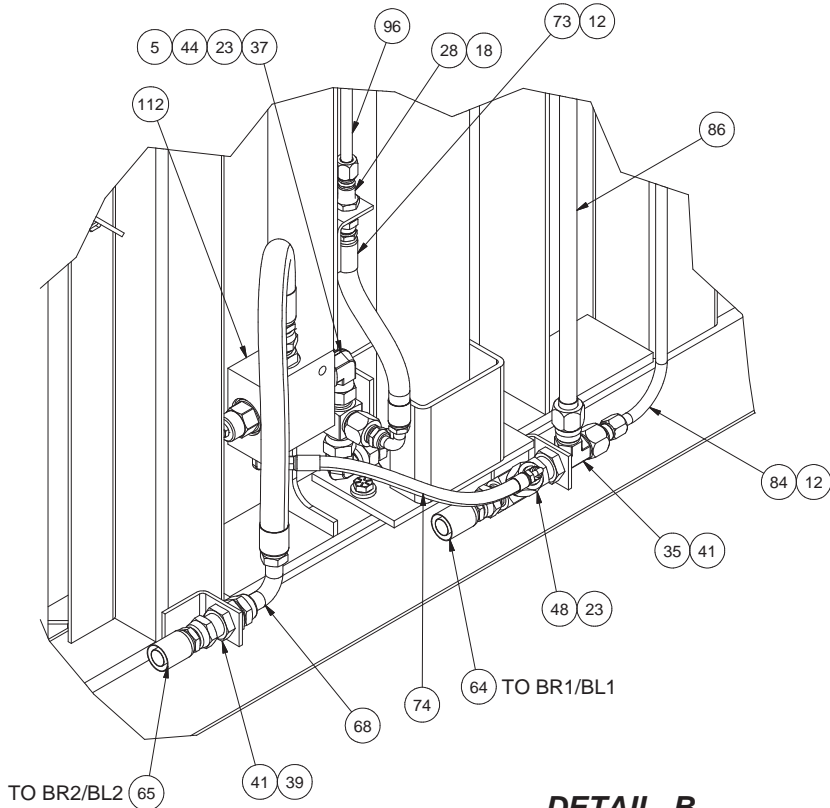

DETAIL B
COUNTERBALANCE ROUTING

NOTES:

2-1 - PLACE HOSE PROTECTORS BETWEEN HOSE AND HITCH.
FASTEN WITH BLACK ZIP TIES.

2-2 - TORQUE FLANGE FASTENERS IN A DIAGONAL PATTERN IN
SMALL INCREMENTS TO 111 FT-LBS.

Hydraulic Hose & Tube Installation

Page 4 of 8

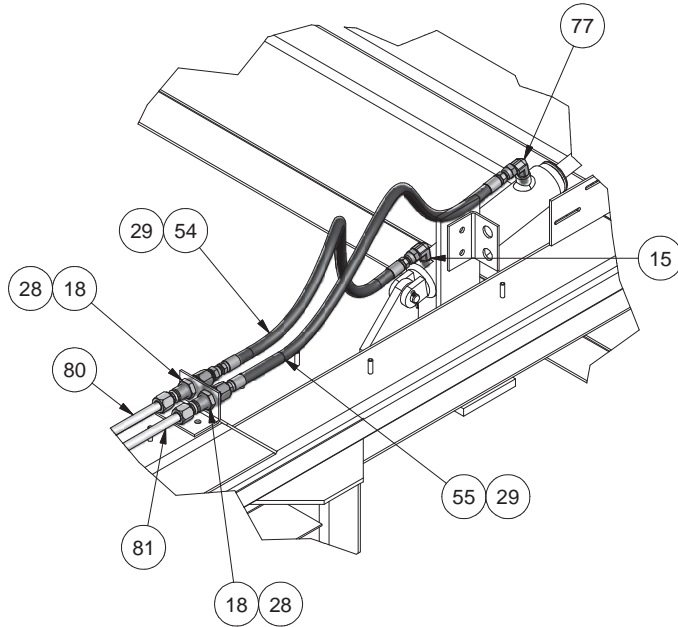

DETAIL C

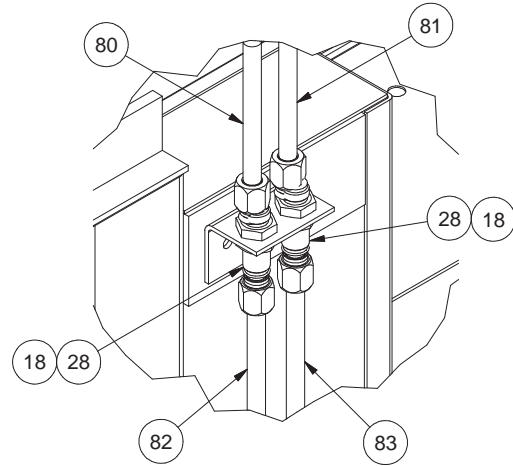

DETAIL D

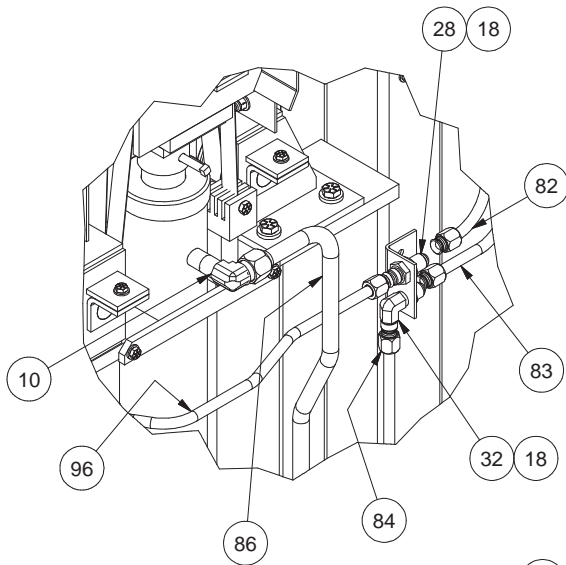

DETAIL E

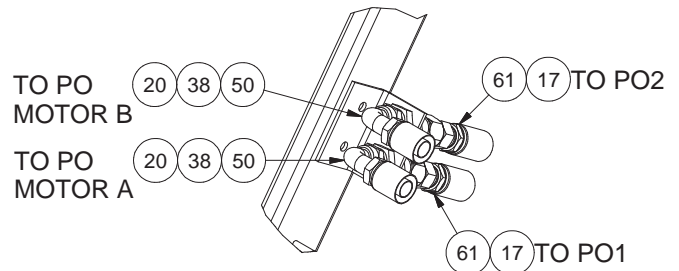

DETAIL F
PO BULKHEAD

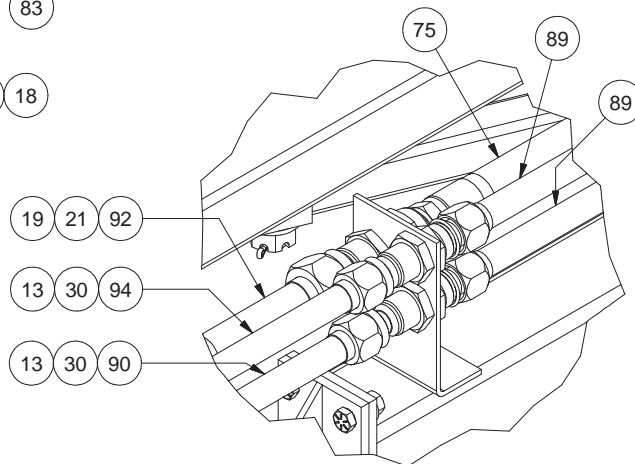

DETAIL G
PUSHER & TIE ARMS BULKHEAD 1

Hydraulic Hose & Tube Installation

Page 5 of 8

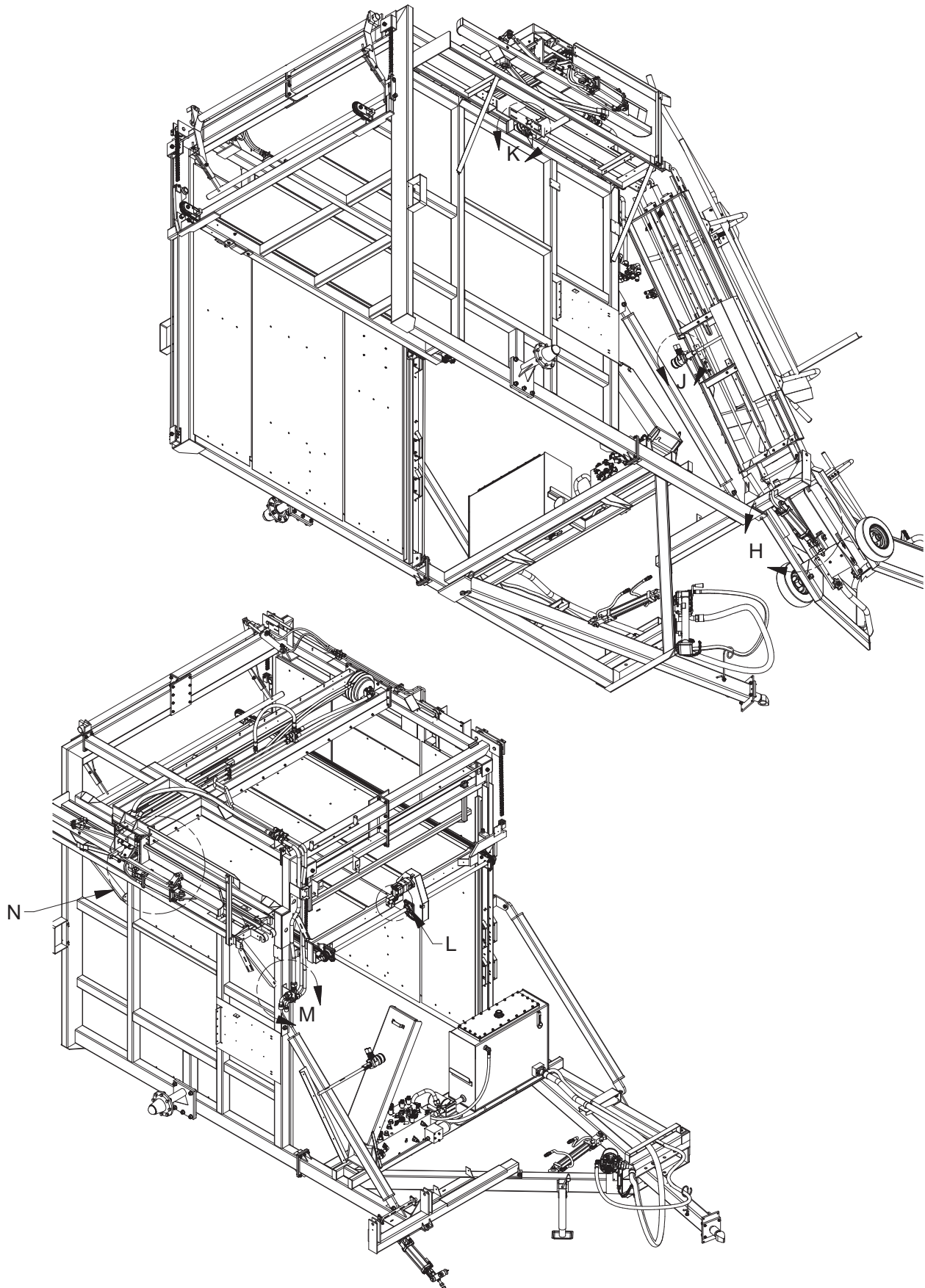

Hydraulic Hose & Tube Installation

Page 6 of 8

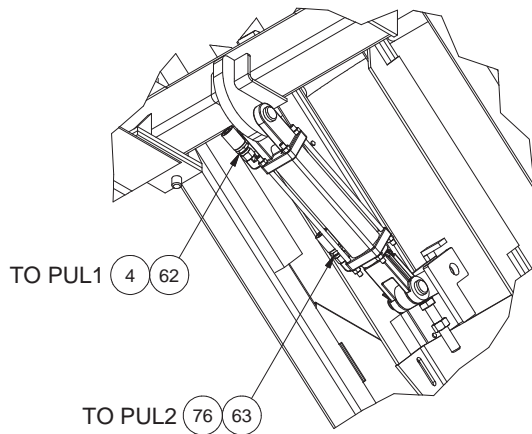

DETAIL H
PICKUP CYLINDER

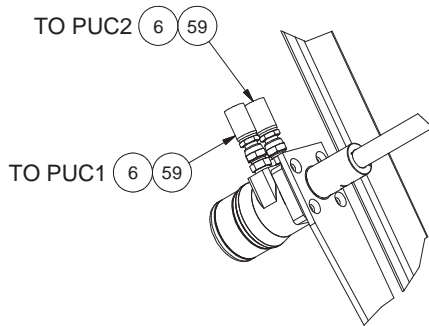

DETAIL J
PICKUP CHAIN MOTOR

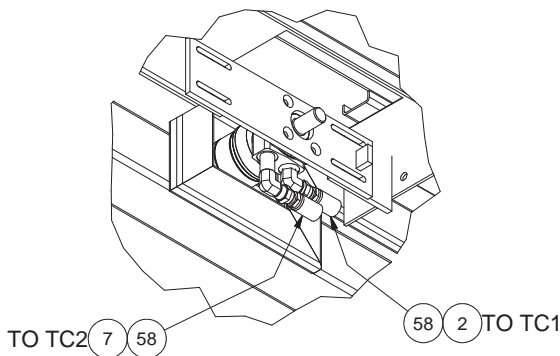

DETAIL K
TABLE CHAIN MOTOR

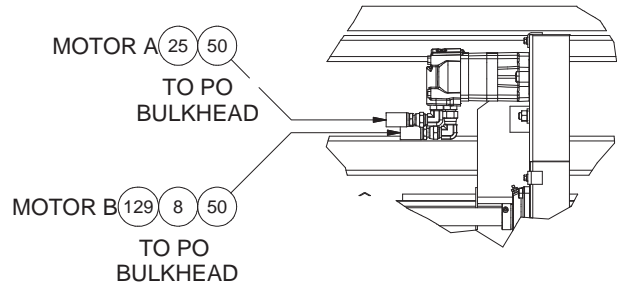

DETAIL L
PUSHOFF MOTOR

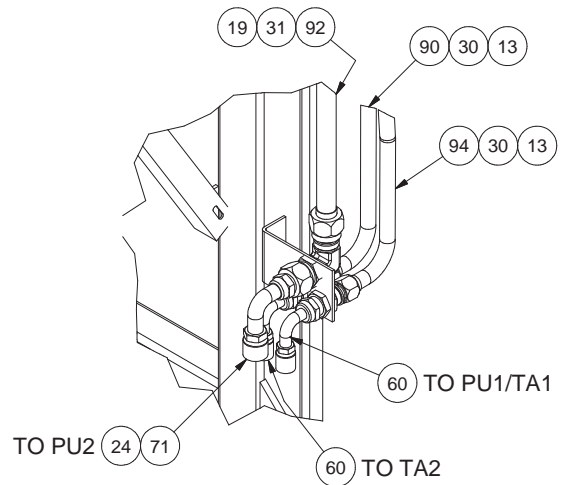

DETAIL M
PUSHER & TIE ARMS BULKHEAD 2

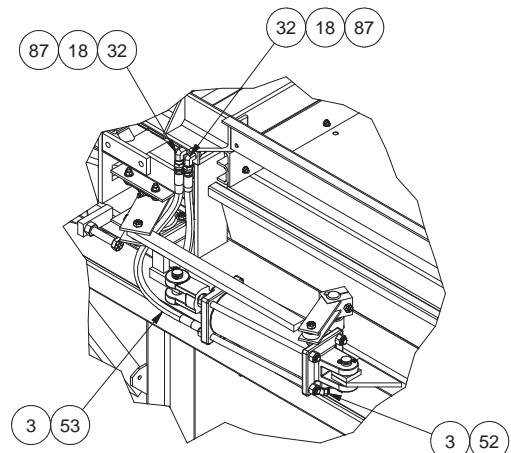

DETAIL N
TIE ARMS

Hydraulic Hose & Tube Installation

Page 7 of 8

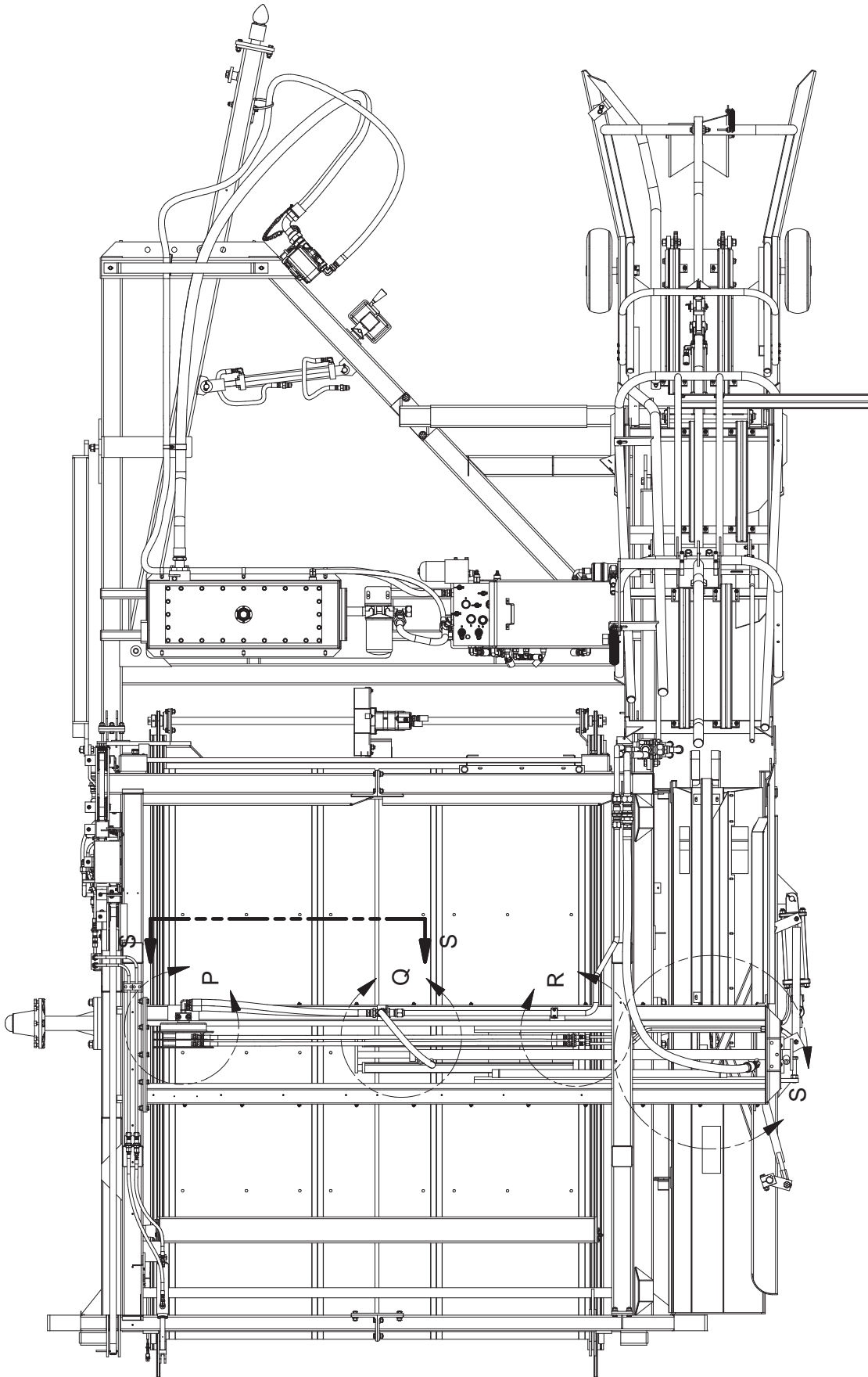

Hydraulic Hose & Tube Installation

Page 8 of 8

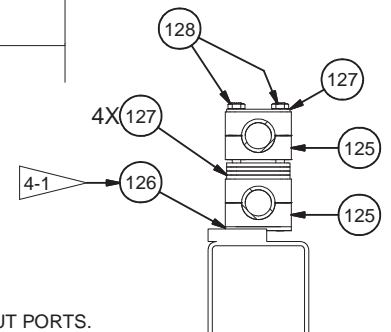
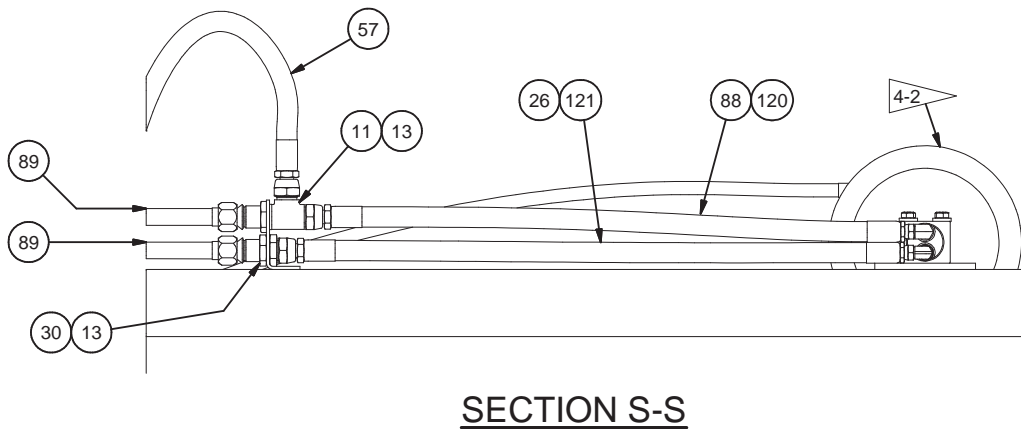
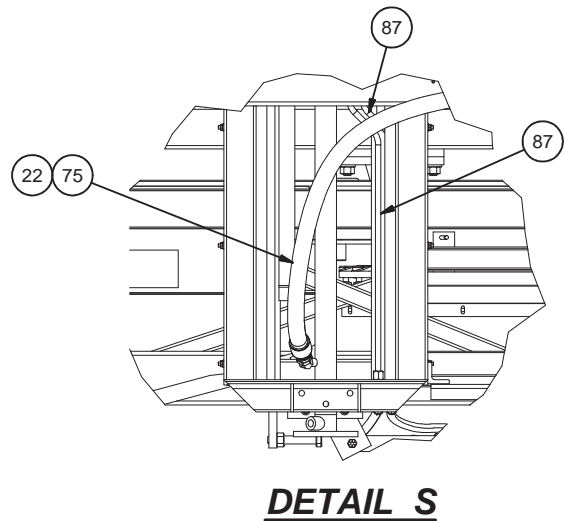
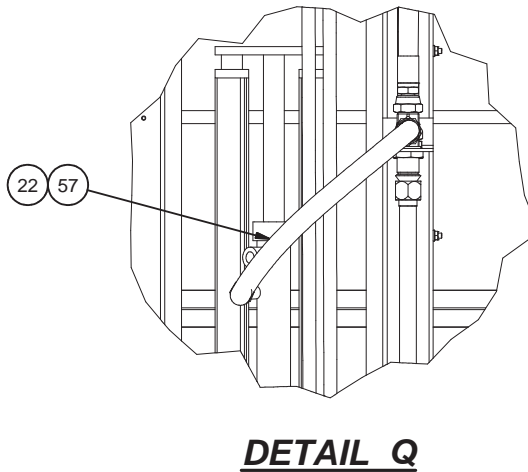
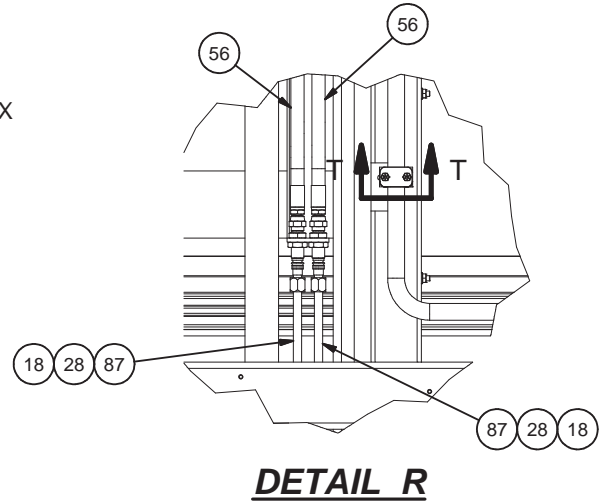
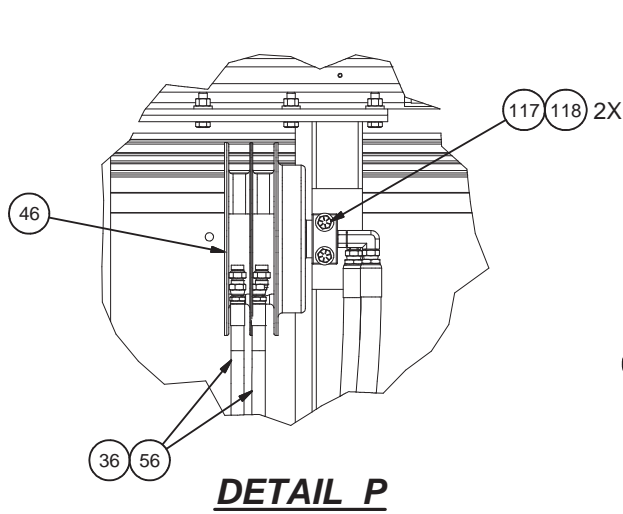

NOTES:

4-1 - TACK WELD ITEM 126 ON EXISTING BOSS AT ASSEMBLY.

4-2 - ORIENT REEL SO THAT TOP PORT CORRESPONDS TO HOSE LINE FURTHEST FROM THE INPUT PORTS.

This page is intentionally left blank.

Manifold Assembly

Page 1 of 1

Item	Part No.	Qty	Description	Item	Part No.	Qty	Description
	906588		Manifold Assembly				
1	906589	1	. Valve, Counterbalance	3	209215	1	. Fitting
	243815	1	. . Seal Kit	4	223784	1	. Fitting
2	906590	1	. Valve Body				

Rev -

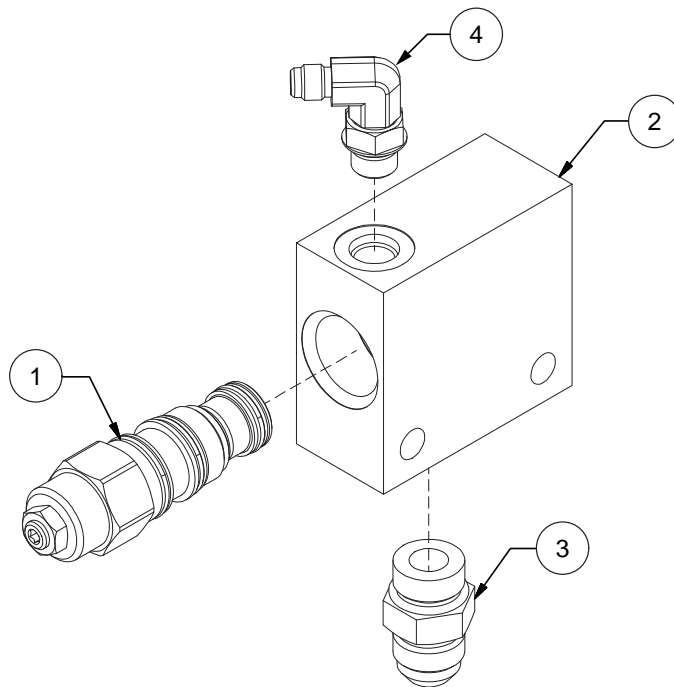

Limit Switch Locations

Page 1 of 2

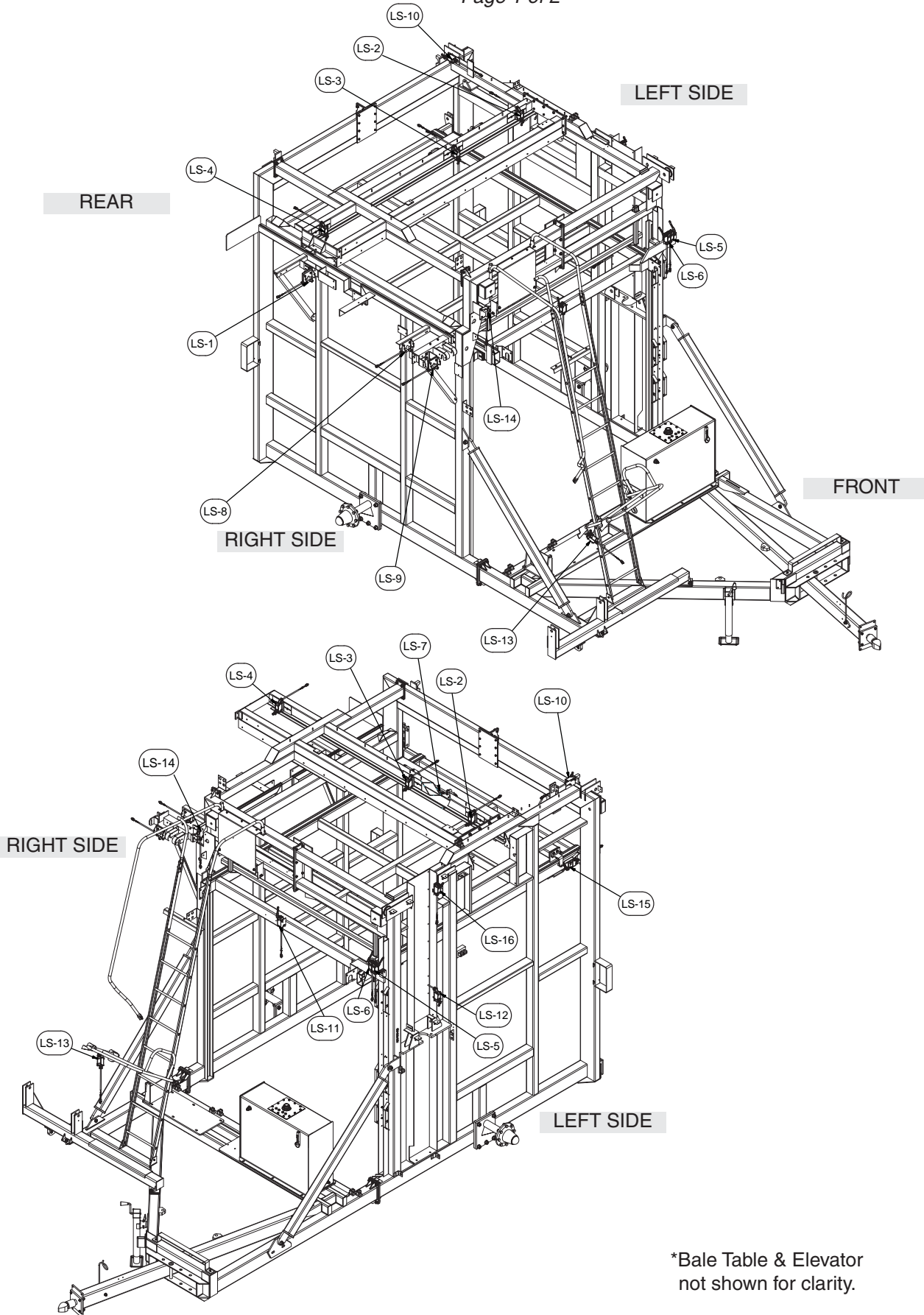

*Bale Table & Elevator
not shown for clarity.

Limit Switch Locations

Page 2 of 2

Sensor No.	Description	Installation Page #
LS1	Bale Table, Bale Position Sensor	47
LS2	Pusher Position, Long Stroke	97
LS3	Pusher Position, Short Stroke	97
LS4	Pusher Position, Home	97
LS5	Load Bed Cam Sensor	97
LS6	Load Bed Cam Sensor	97
LS7	Table Height Index Sensor	103
LS8	Bale Table, Bale Sensor	47
LS9	Bale Table, Bale Sensor	47
LS10	Bale Retainer Sensor	97
LS11	Push Off Bar, Home	97
LS12	Load Bed Bottom Sensor	97
LS13	Safety Gate Sensor	97
LS14	Bale Table Bale Sensor	47
LS15	Bush Off Bar Limit Sensor	43
LS16	Load Bed Bottom Sensor	97

Limit Switch Installation, LS: 2-6, 10-13, 16

Page 1 of 6

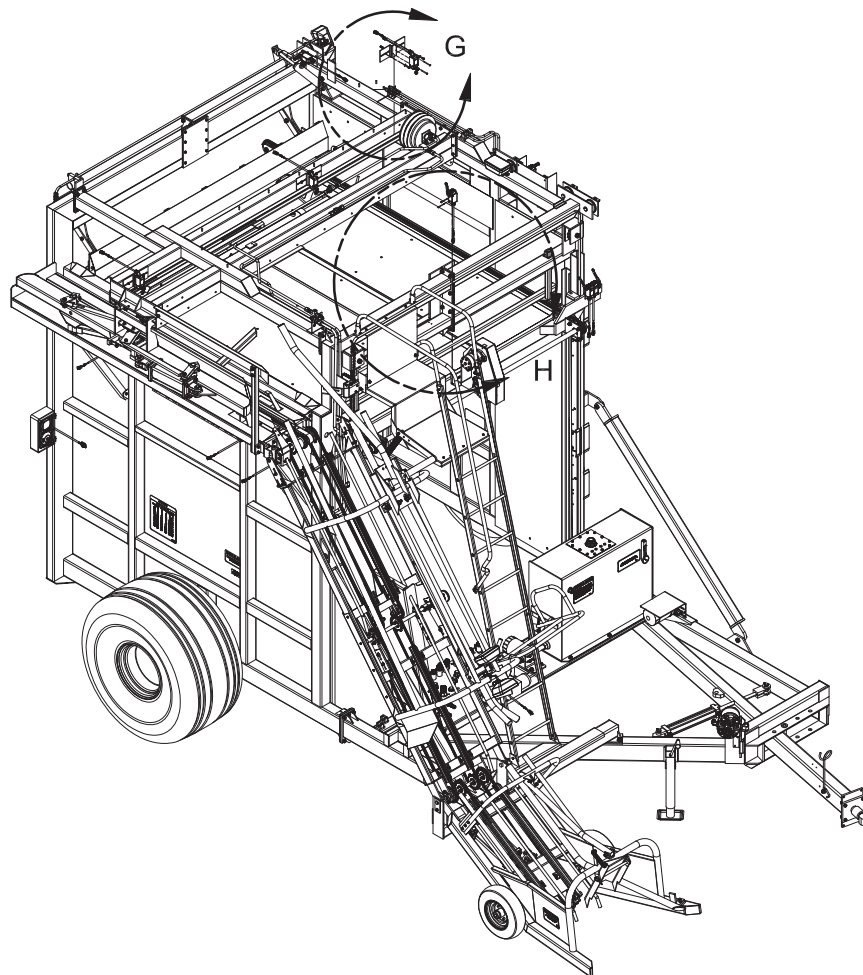
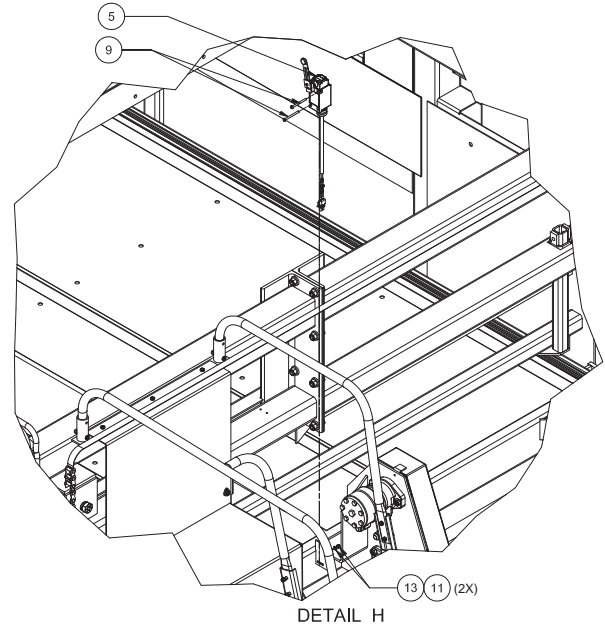
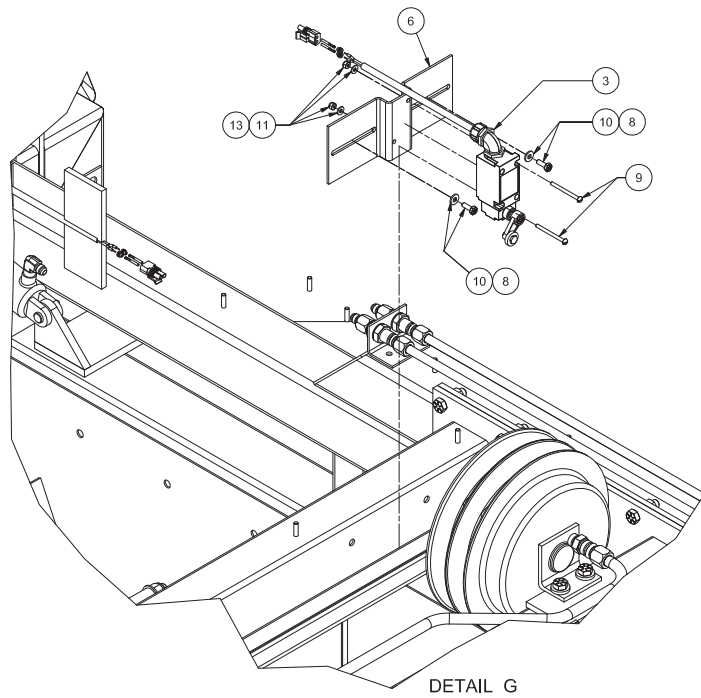

Limit Switch Installation, LS: 2-6, 10-13, 16

Page 2 of 6

Item	Part No.	Qty	Description
	904910		Limit Switch Installation
1	* 904943	1	. Switch Assembly, Limit (LS-5) (Page 109)
2	* 904944	1	. Switch Assembly, Limit (LS-6) (Page 109)
3	* 904945	4	. Switch Assembly, Limit (LS-2, 3, 4, 12) (Page 109)
4	* 904946	2	. Switch Assembly, Limit (LS-10, 16) (Page 109)
5	* 904947	1	. Switch Assembly, Limit (LS-11) (Page 109)
6	MNT0073294	3	. Plate, Mounting
7	904950	2	. Bracket, Limit Switch
8	224120W	10	. Capscrew
9	SMR1032175	20	. Machine Screw
10	221763W	10	. Washer
11	223799	20	. Nut, Esna
12	R13811189	4	. Locknut
13	00103338	20	. Flat Washer
14	* 902435	1	. Index Paddle Assembly (Page 103)
15	* 906168	1	. Switch Assembly, Limit (LS-13) (Page 107)

* See Separate Page

Rev E

Limit Switch Installation, LS: 2-6, 10-13, 16

Page 3 of 6

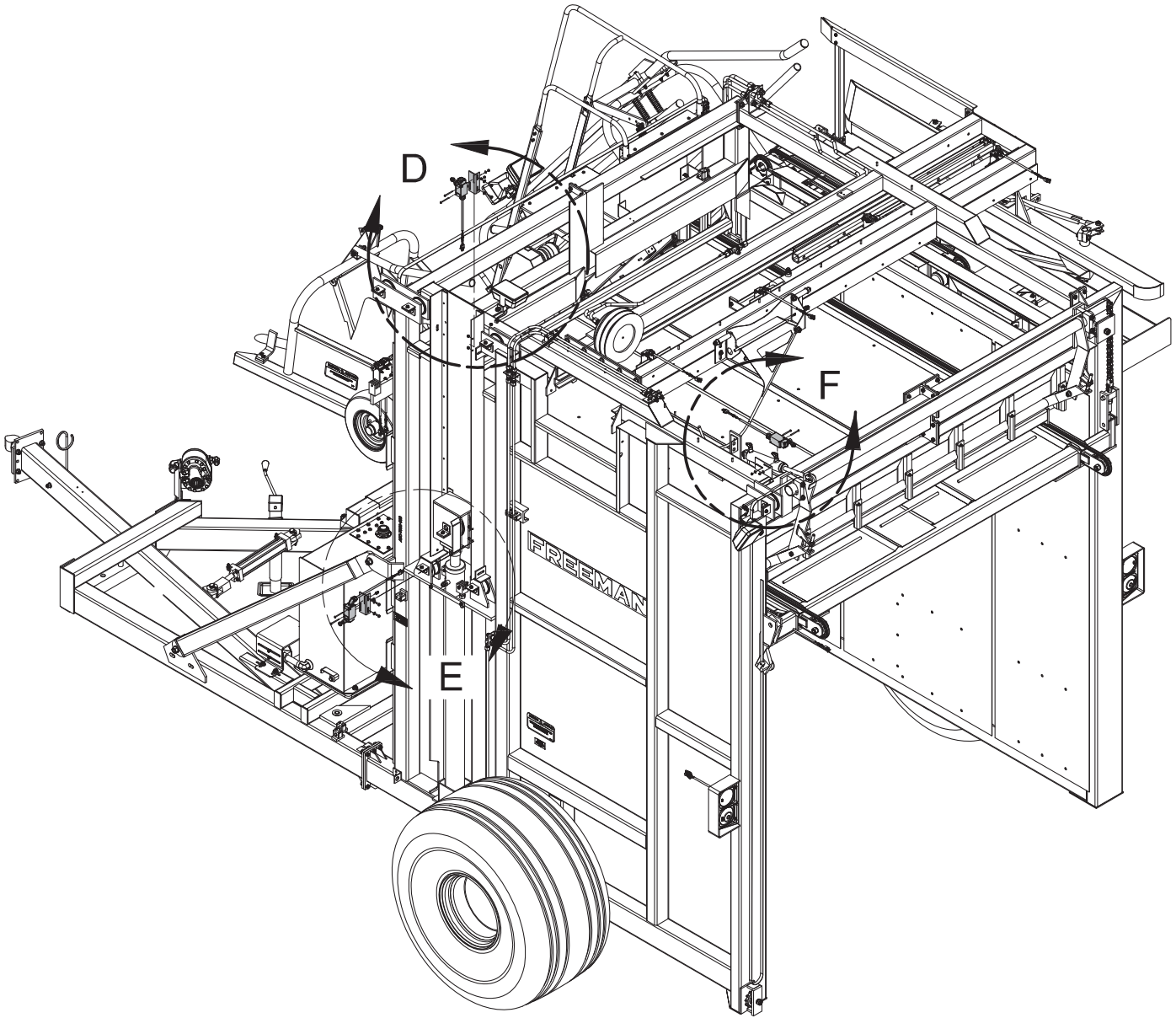

Limit Switch Installation, LS: 2-6, 10-13, 16

Page 4 of 6

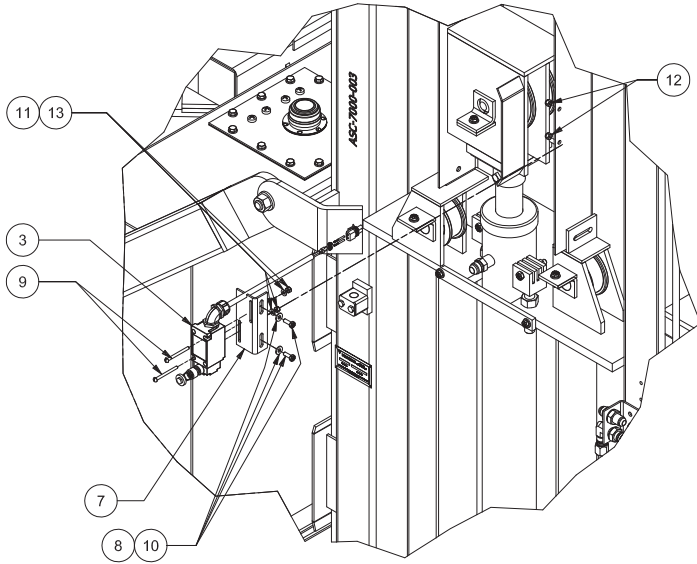

DETAIL E

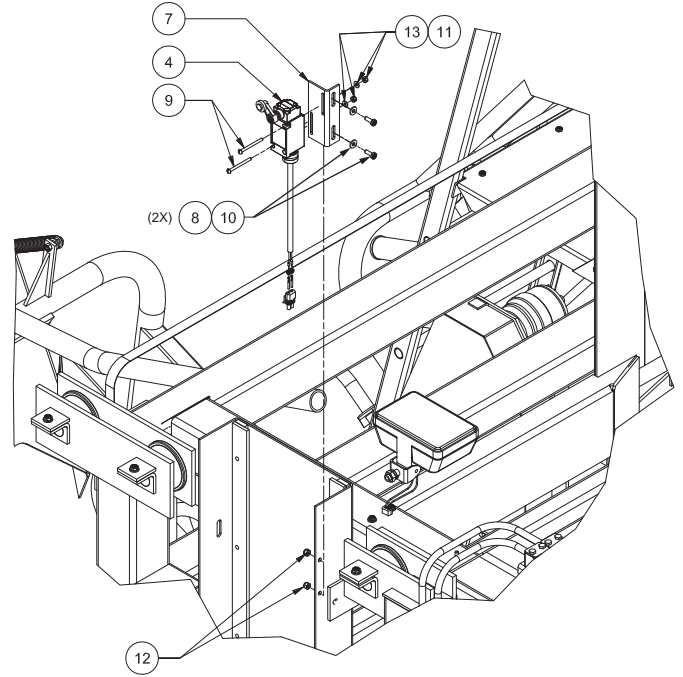

DETAIL D

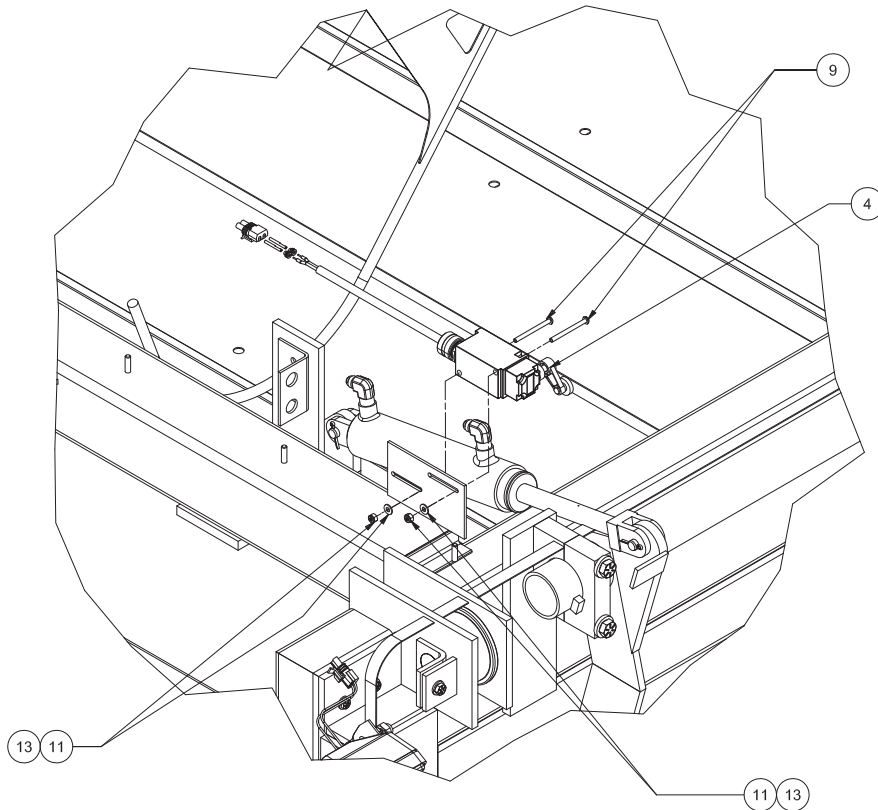

DETAIL F

Limit Switch Installation, LS: 2-6, 10-13, 16

Page 5 of 6

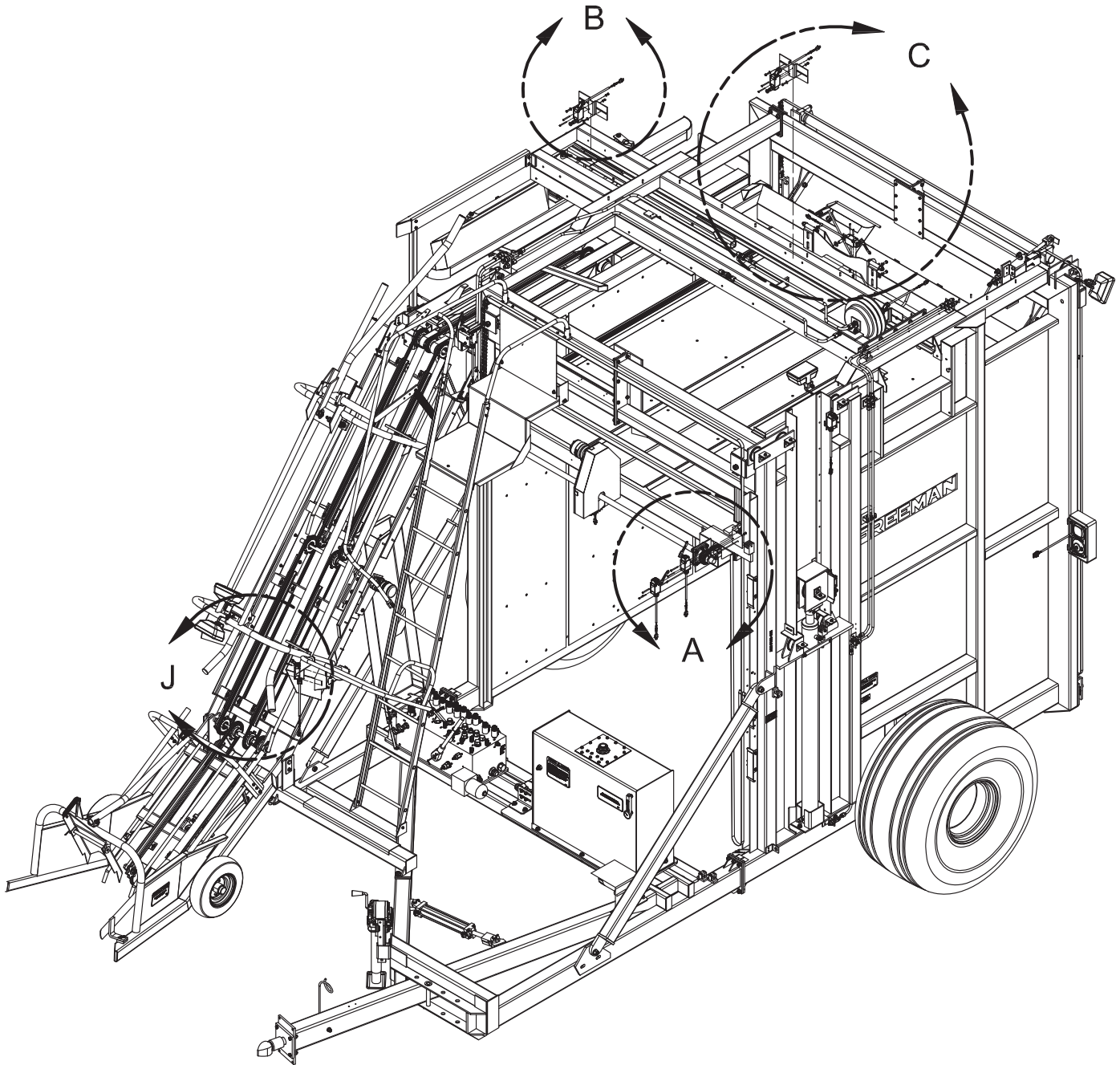

Limit Switch Installation, LS: 2-6, 10-13, 16

Page 6 of 6

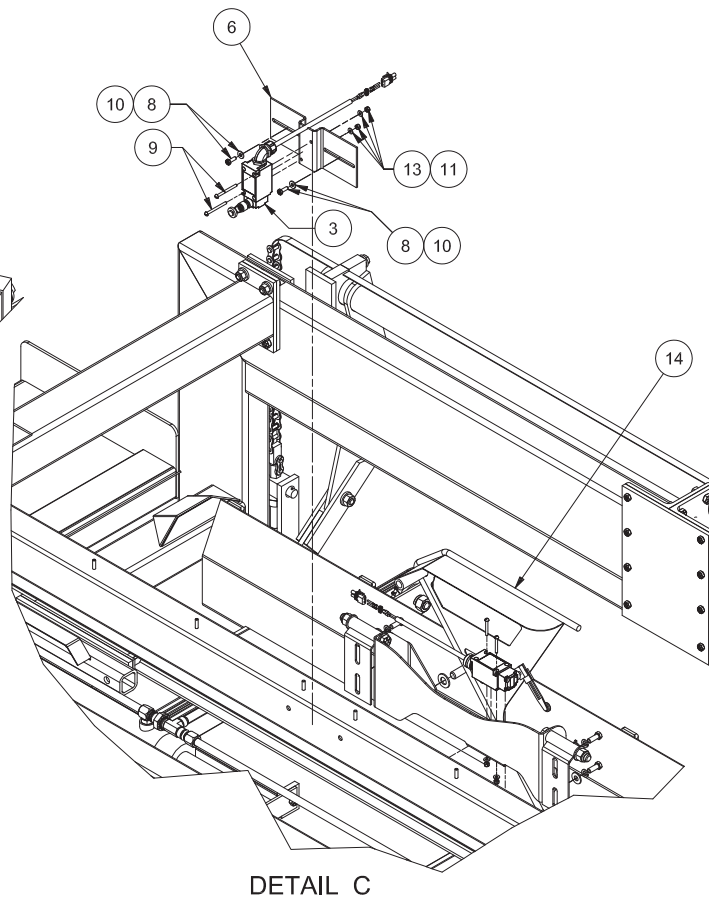
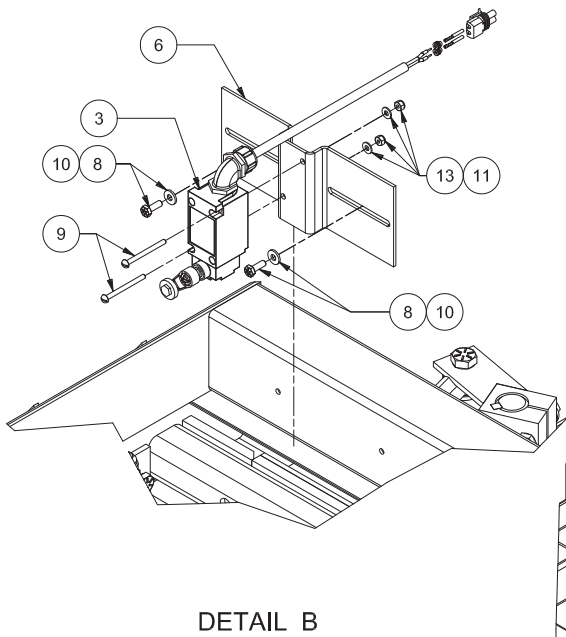
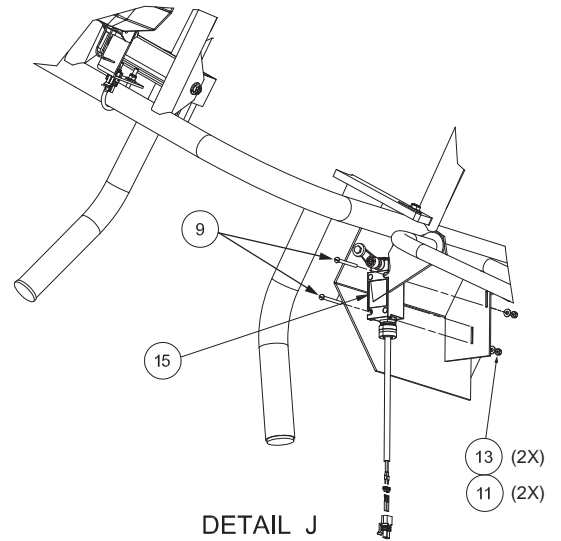
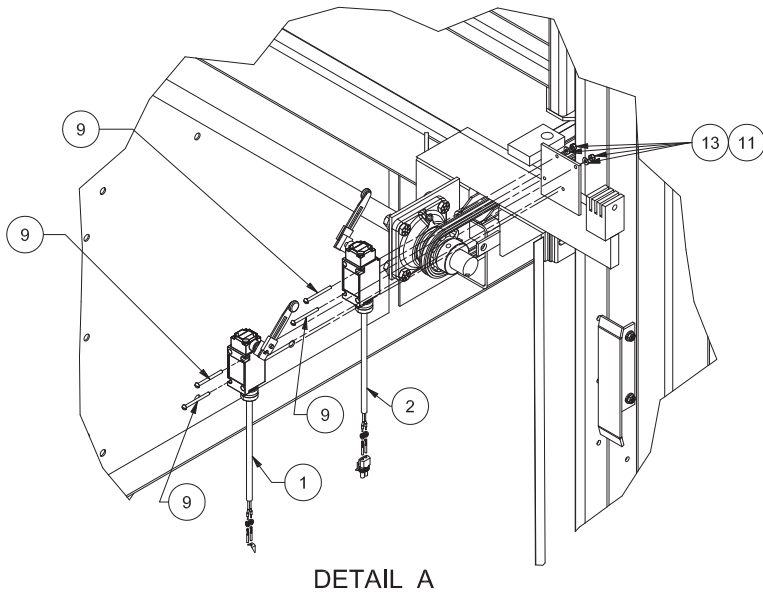

Index Paddle Assembly

Page 1 of 2

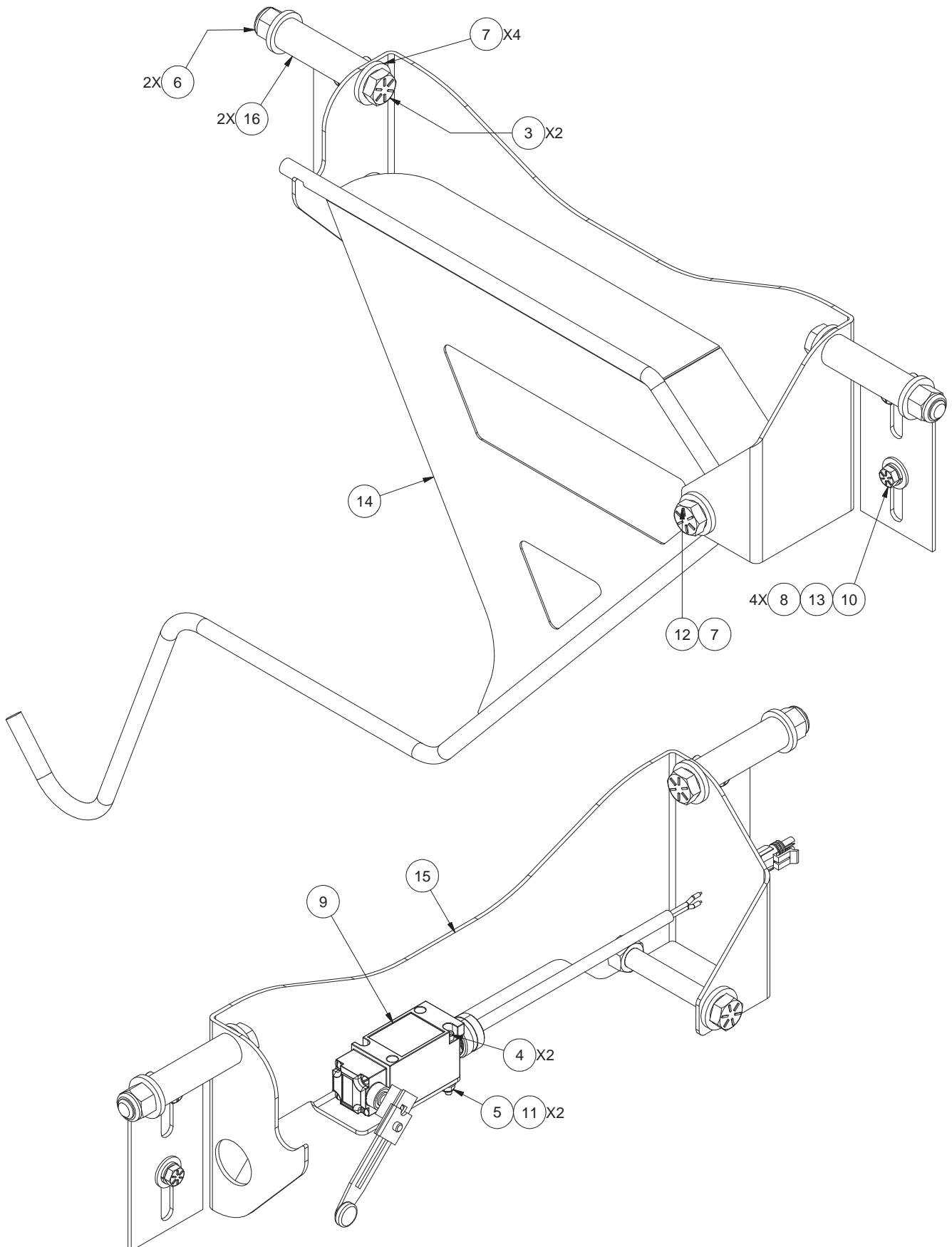

Index Paddle Assembly

Page 2 of 2

Item	Part No.	Qty	Description	Item	Part No.	Qty	Description
	902435		Index Paddle Assembly				
3	R13809383	2	. Capscrew	10	Y17C-0616	4	. Capscrew
4	236480	2	. Capscrew	11	00103338	2	. Flat Washer
5	R13809543	2	. Locknut	12	R13809382	1	. Capscrew
6	R13811195	2	. Locknut	13	R13812514	4	. Lockwasher
7	R13811435	5	. Hard Washer	14	902333	1	. Paddle
8	R13811447	4	. Flat Washer	15	902335	1	. Mount
9	* 904944	1	. Switch Assy, Limit (LS-7) (Page 109)	16	902488	2	. Pivot

* See Separate Page

Rev A

Limit Switch Assembly, LS: 1, 8, 9, 14, 15 (N.C.)

Page 1 of 2

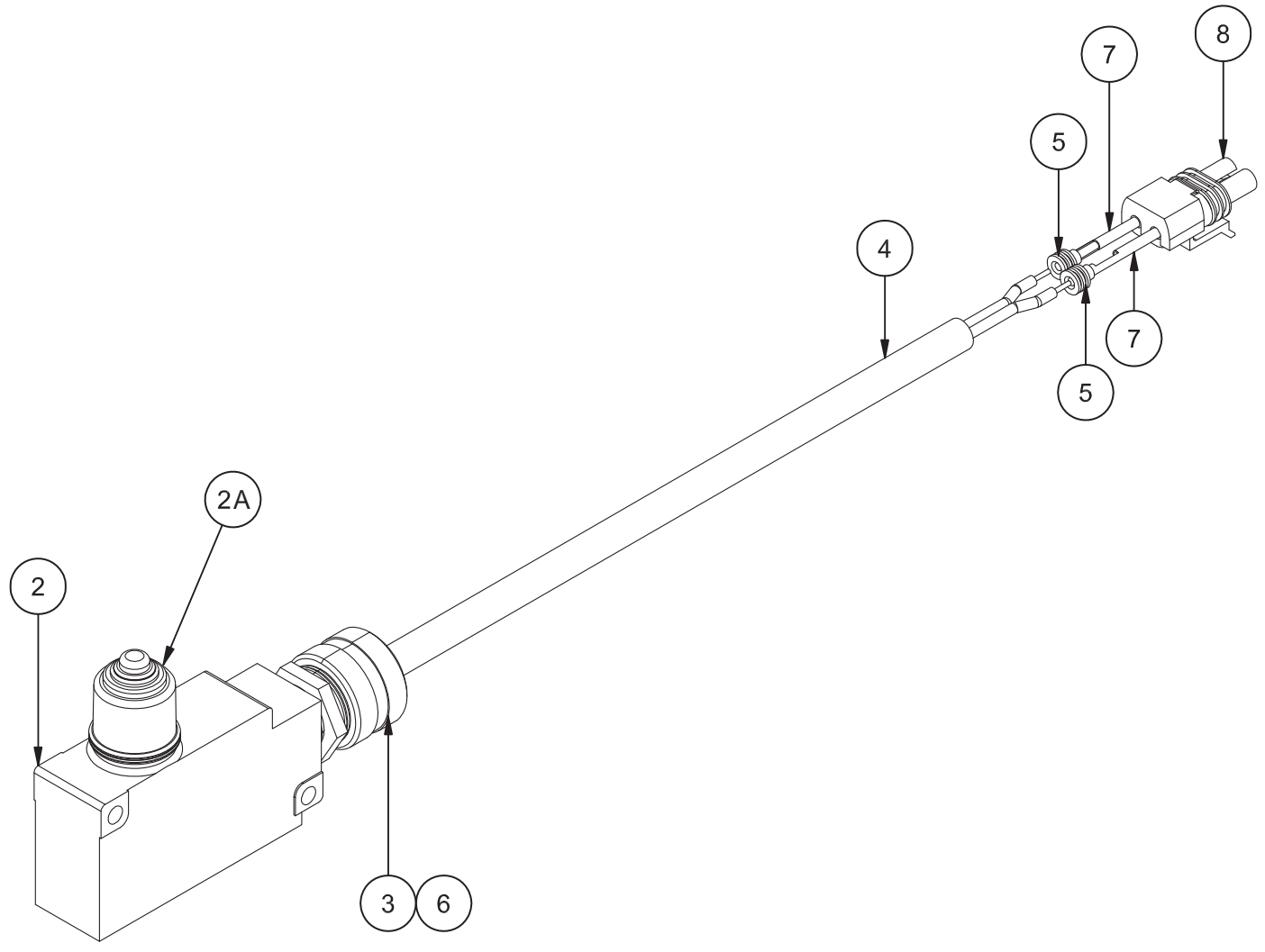

Limit Switch Assembly, LS: 1, 8, 9, 14, 15 (N.C.)

Page 2 of 2

Item	Part No.	Qty	Description	Item	Part No.	Qty	Description
	904997		Switch Assembly, Limit				
	904982	Ref	. Switch Wiring Diagram	4	CBL0000114	1'	. Cable
2	03-158	1	. Switch, Limit, With Seal Boot	5	R740867	2	. Seal, Wire
	03-178	1	.. Repair Kit	6	200247	2	. Terminal Ring
2A	258704	1	.. Seal Boot	7	R740874	2	. Pin, Female
3	CNR0000193	1	. Connector, Cord	8	R740886	1	. Connector, Wire

Rev A

Limit Switch Assembly, LS-13 (N.C.)

Page 1 of 2

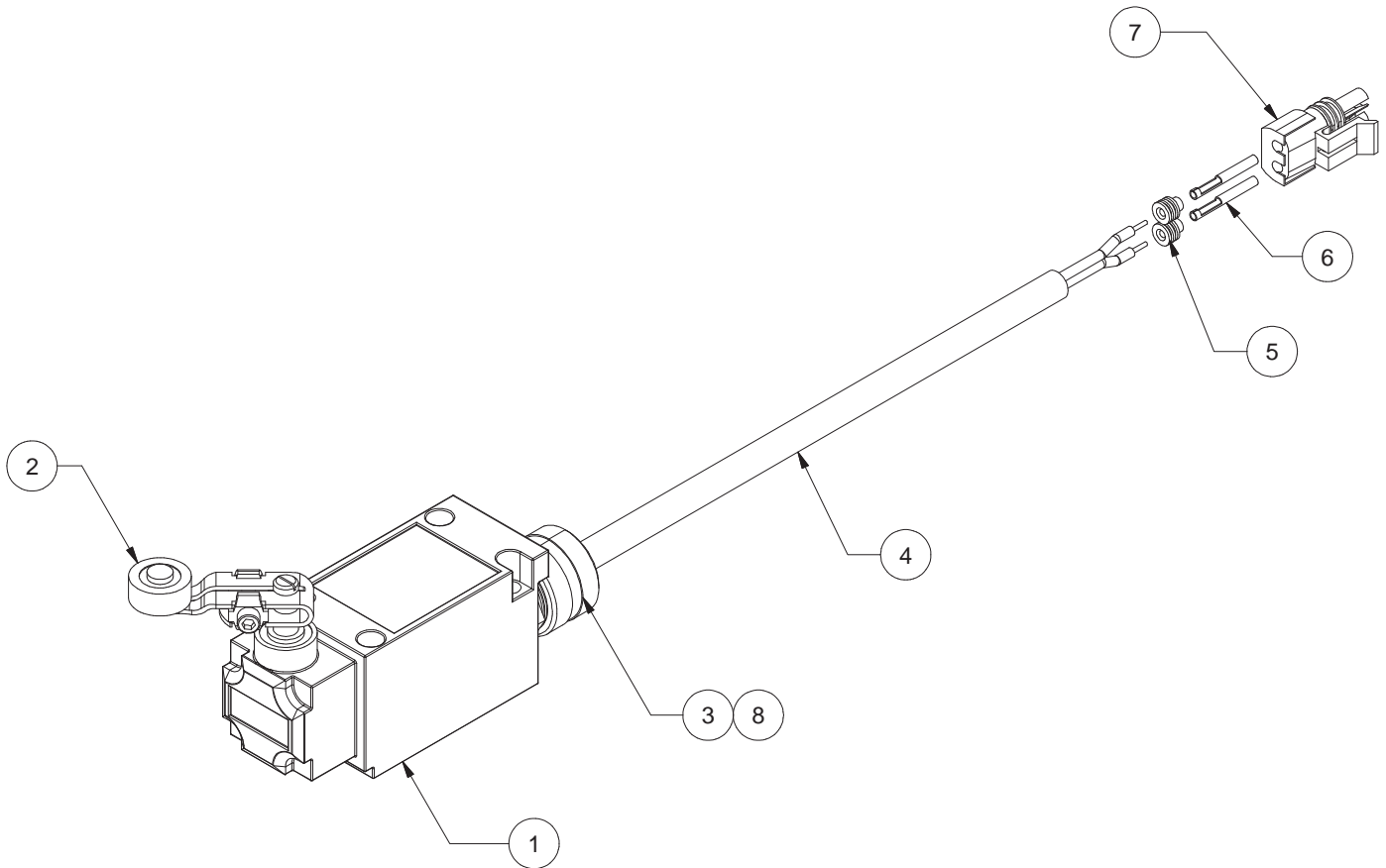

Limit Switch Assembly, LS-13 (N.C.)

Page 2 of 2

Item	Part No.	Qty	Description	Item	Part No.	Qty	Description
	906168		Switch Assembly, Limit				
	904982	Ref	. Switch Wiring Diagram	5	R740867	2	. Seal, Wire
1	SWI0CH5079	1	. Switch, Limit	6	R740874	2	. Pin, Female
2	ARMOCH5001	1	. Limt Switch Roller Arm	7	R740886	1	. Connector, Wire
3	CNR0000193	1	. Connector, Cord	8	200247	2	. Terminal Ring
4	CBL0000114	1'	. Cable				

Rev -

Limit Switch Assembly, LS: 2-7, 10-12, 16 (N.O.)

Page 1 of 2

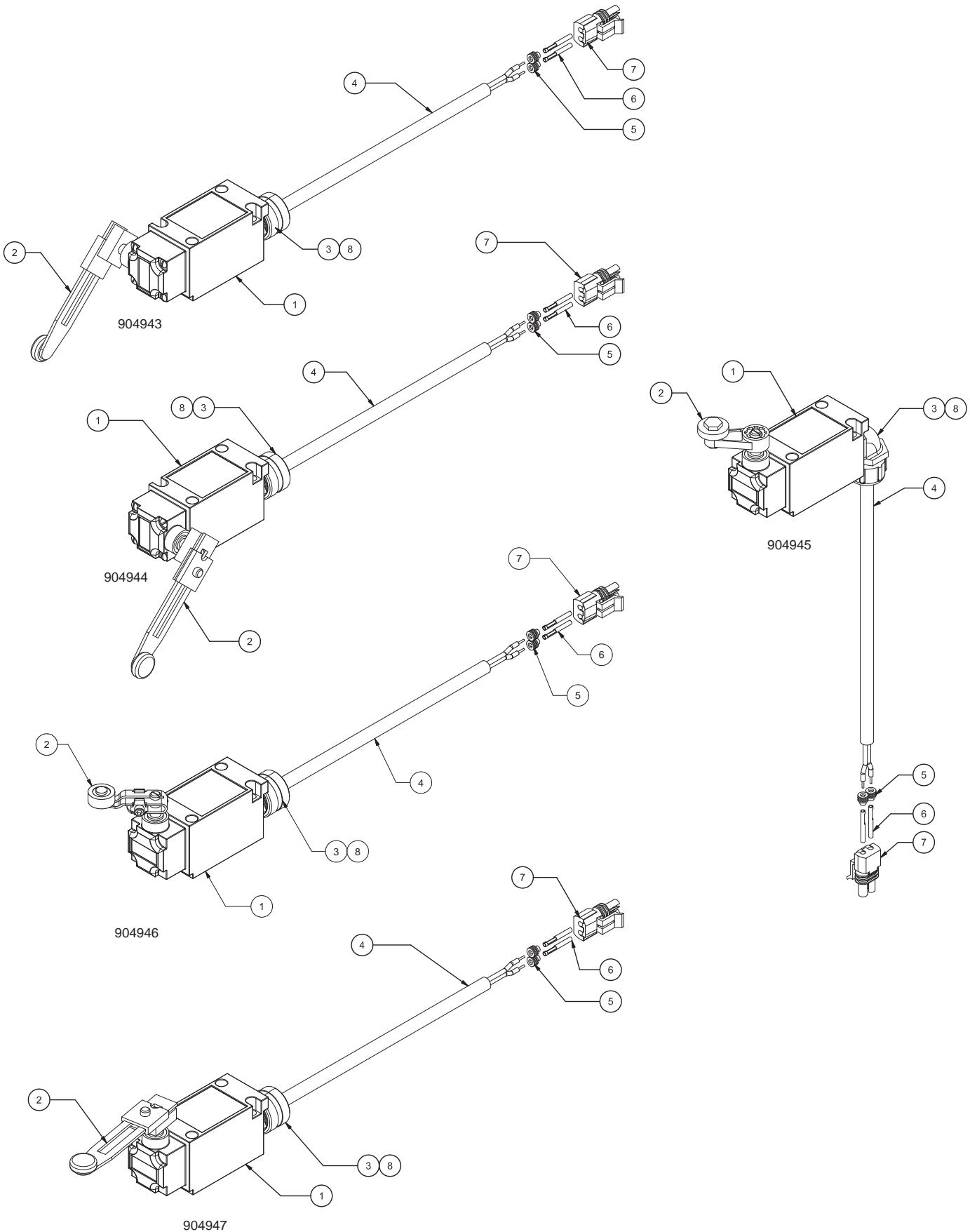

Limit Switch Assembly, LS: 2-7, 10-12, 16 (N.O.)

Page 2 of 2

Item	Part No.	Qty	Description	Item	Part No.	Qty	Description
	904943		Switch Assy, Limit (LS-5)				
	904944		Switch Assy, Limit (LS-6, 7)	4	CBL0000114	1'	. 2 Conductor Black Cable
	904945		Switch Assy, Limit (LS-2, 3, 4, 12)	5	R740867	2	. Seal, Wire
	904946		Switch Assy, Limit (LS-10, 16)	6	R740874	2	. Pin, Female
	904947		Switch Assy, Limit (LS-11)	7	R740886	1	. Connector, Wire
1	* -----	1	. Switch, Limit	8	200247	2	. Terminal Ring
2	* -----	1	. Operator, Roller Type		904982	Ref	. Switch Wiring Diagram
3	* -----	1	. Connector, Cord				

* See Chart

PART NUMBER	REF NO. 1	REF NO. 2	REF NO. 3	REV	WIRED
904943	904942	ARM0CH5084	CRN0000193	A	NO
904944	904941	ARM0CH5084	CRN0000193	A	NO
904945	SWI0CH5079	ARM0CH5001	231997	C	NO
904946	SWI0CH5079	ARM0CH5001	CRN0000193	C	NO
904947	SWI0CH5079	ARM0CH5084	CRN0000193	A	NO

Lights Installation

Page 1 of 4

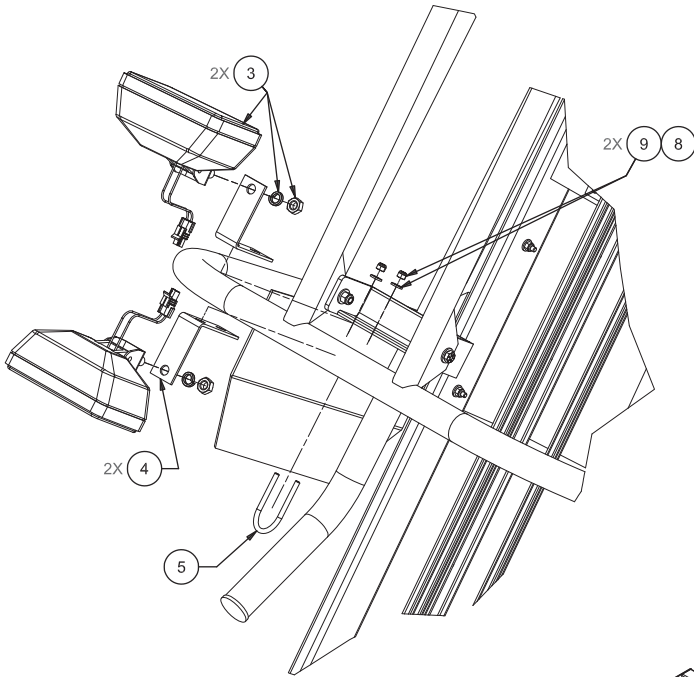

DETAIL A

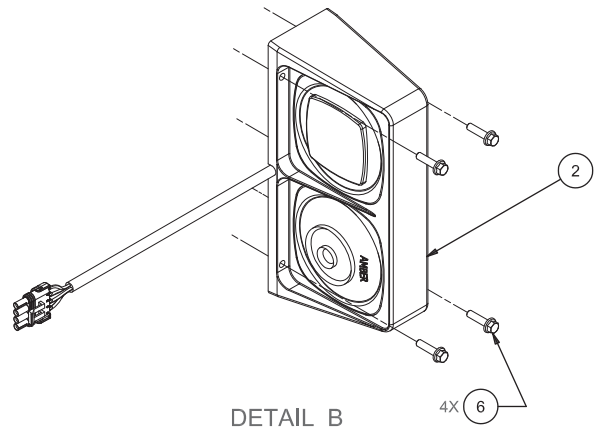

DETAIL B

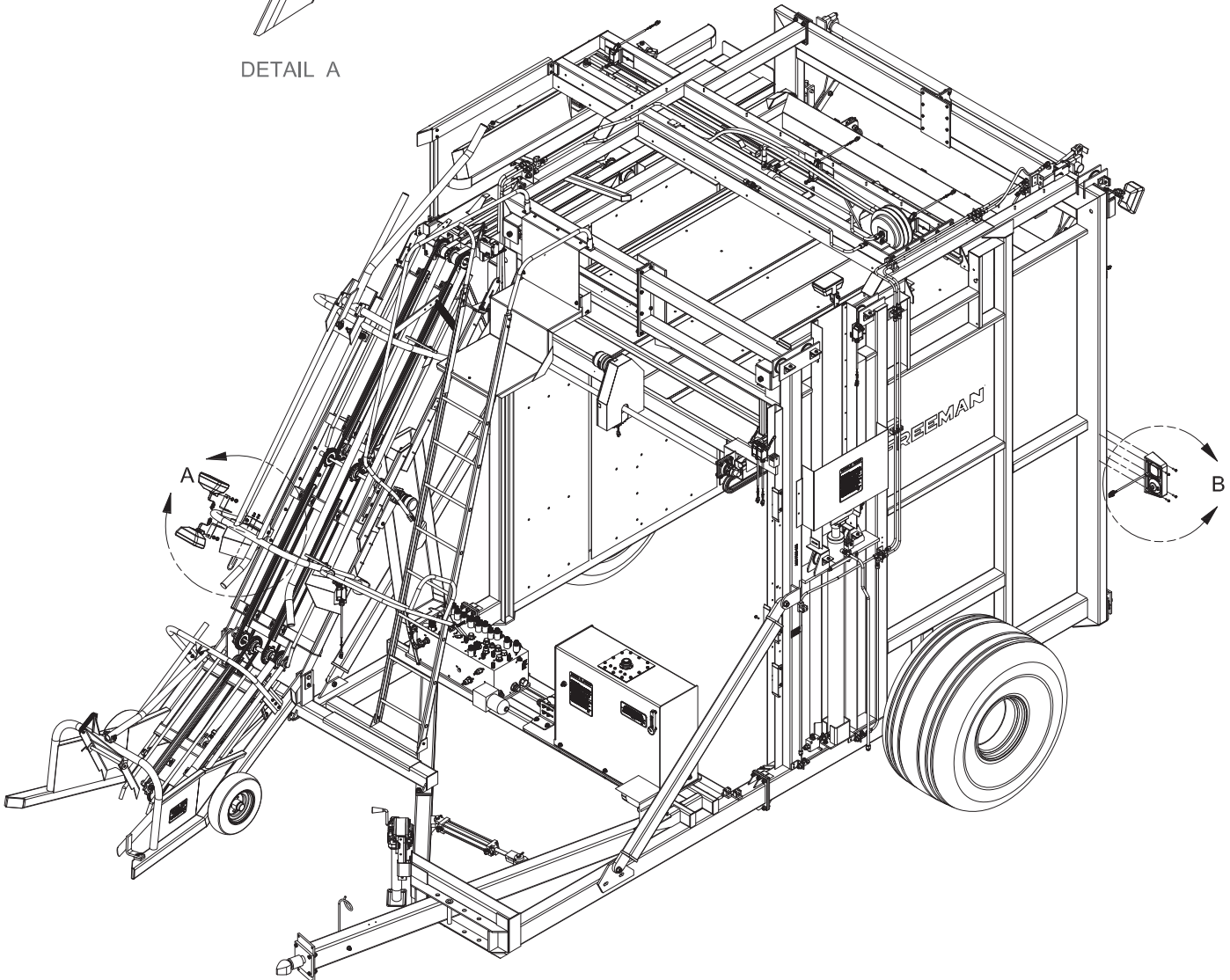

Lights Installation

Page 2 of 4

Item	Part No.	Qty	Description	Item	Part No.	Qty	Description
	904915		Lights Installation				
1	LIT037164B	1	. Light Assembly, RH	6	399741W	8	. Screw
2	LIT037163B	1	. Light Assembly, LH	7	R13810993	4	. Capscrew
3	901521	4	. Light Assembly, Work	8	221763W	6	. Washer
4	BKT0034995	4	. Bracket	9	R13811189	6	. Locknut
5	256890	1	. U-Bolt	10	904952	1	. Highway Light Harness

Rev A

Lights Installation

Page 3 of 4

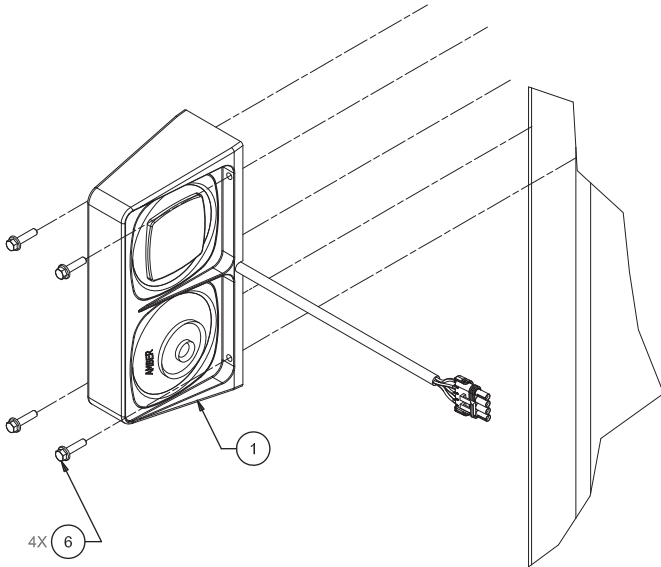

DETAIL D

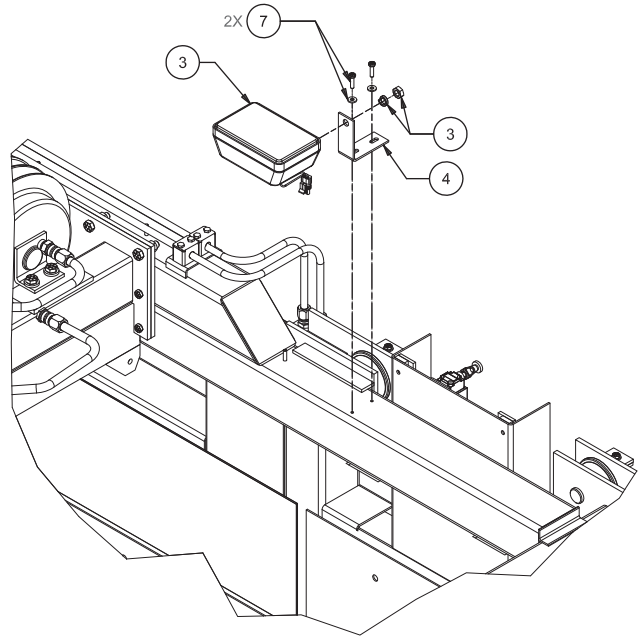

DETAIL C

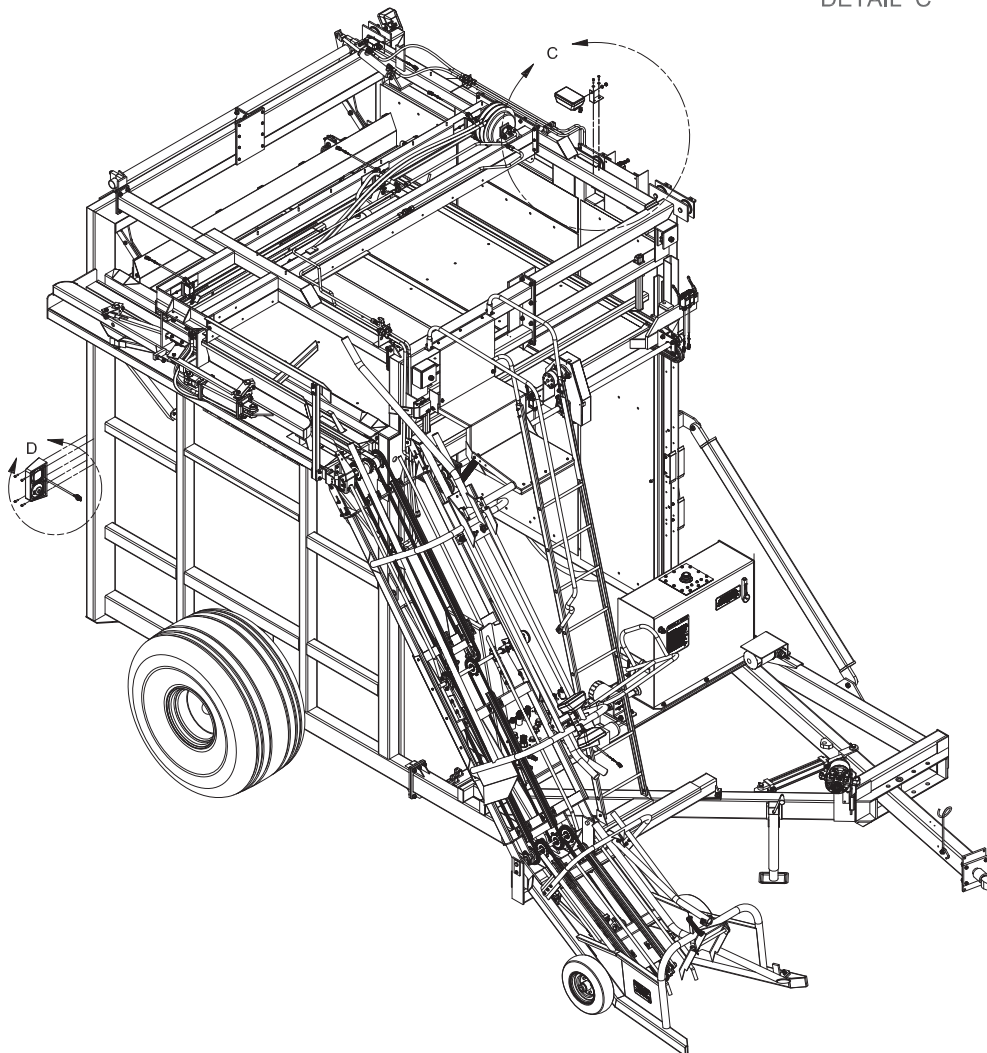

Lights Installation

Page 4 of 4

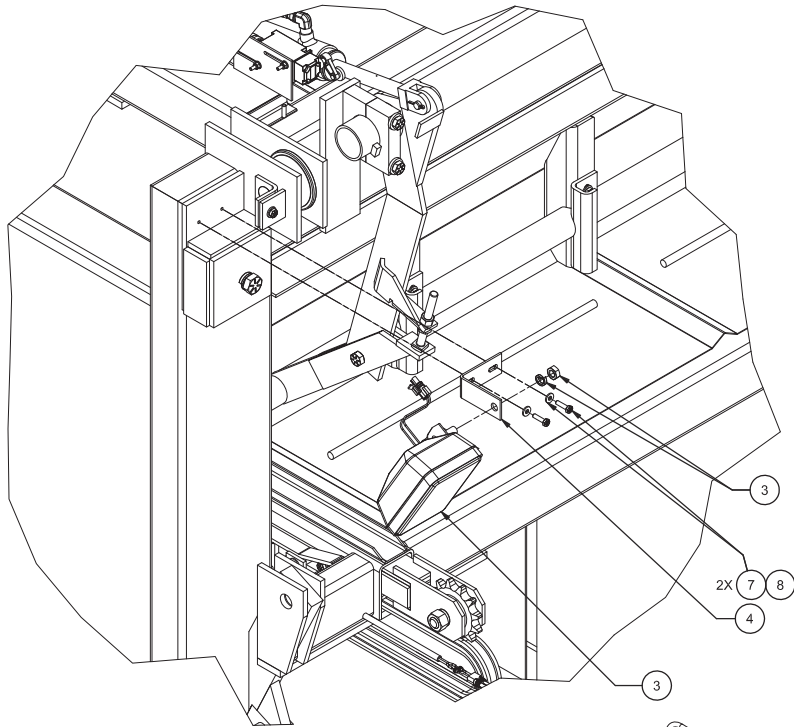

DETAIL E

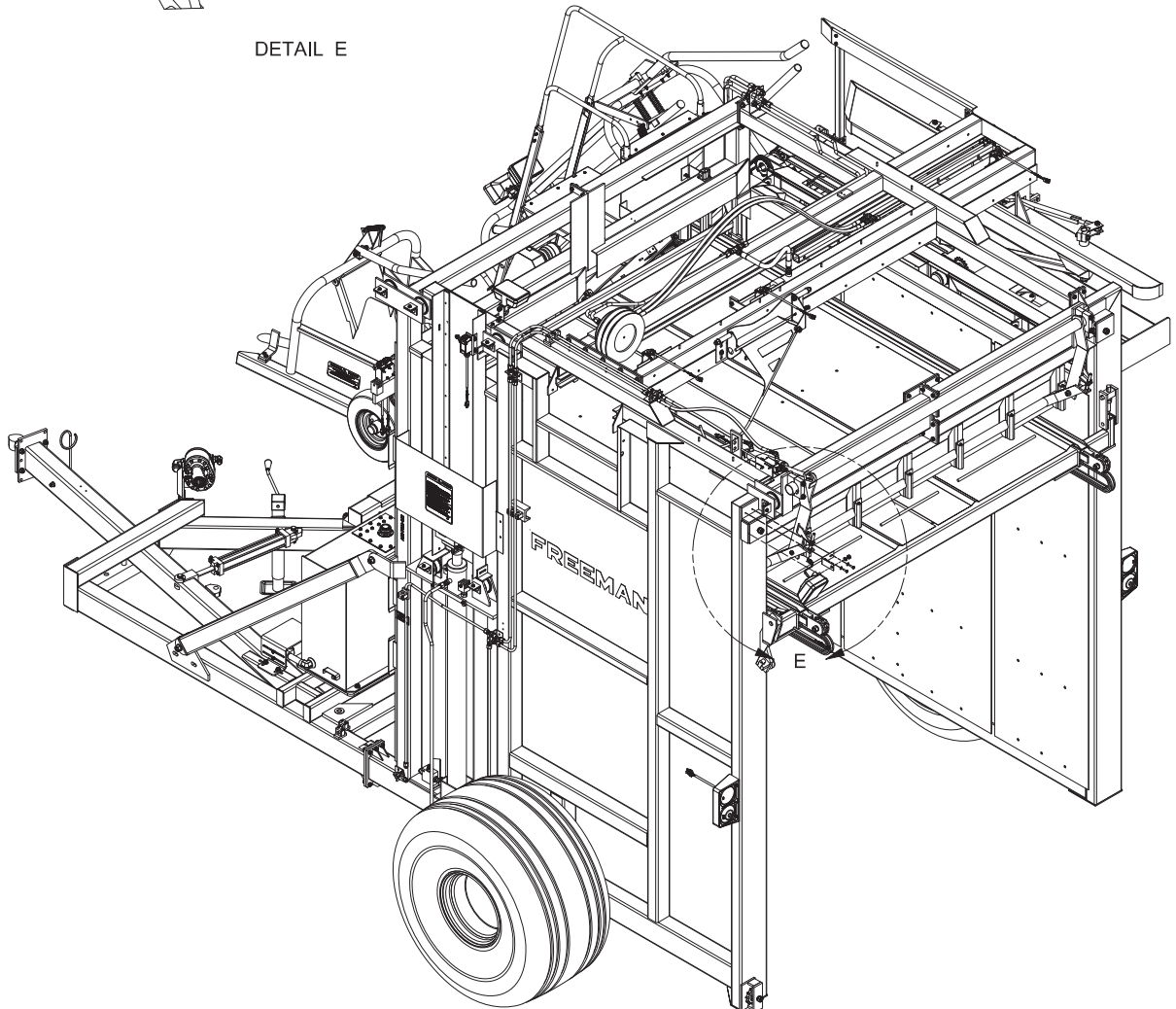

Decal Installation

Page 1 of 4

NOTES:

- 1 ▶ SAME LOCATION BOTH SIDES OF BALE WAGON
- 2 ▶ INSTALL ON WHEEL NEXT TO VALVE STEM (BOTH SIDES OF BALE WAGON)
- 3 ▶ INSTALL BOTH SIDES OF PICKUP ASSEMBLY

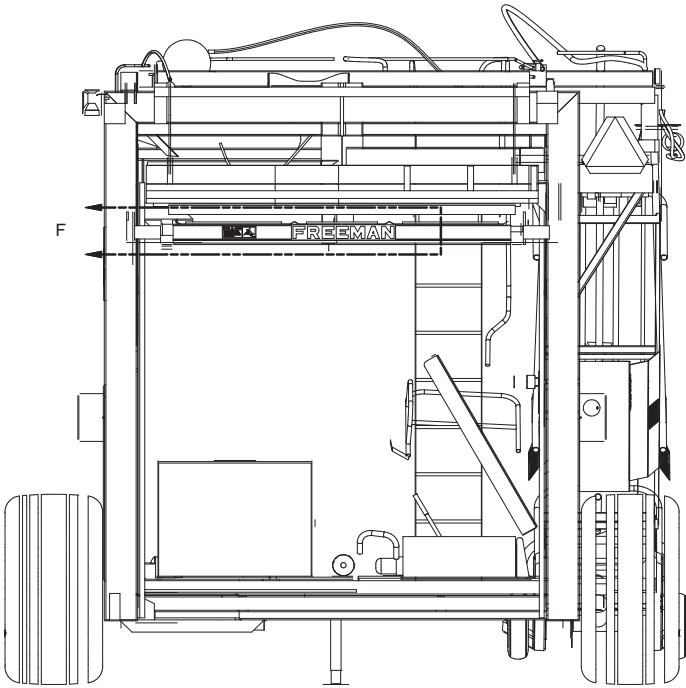

VIEW E-E

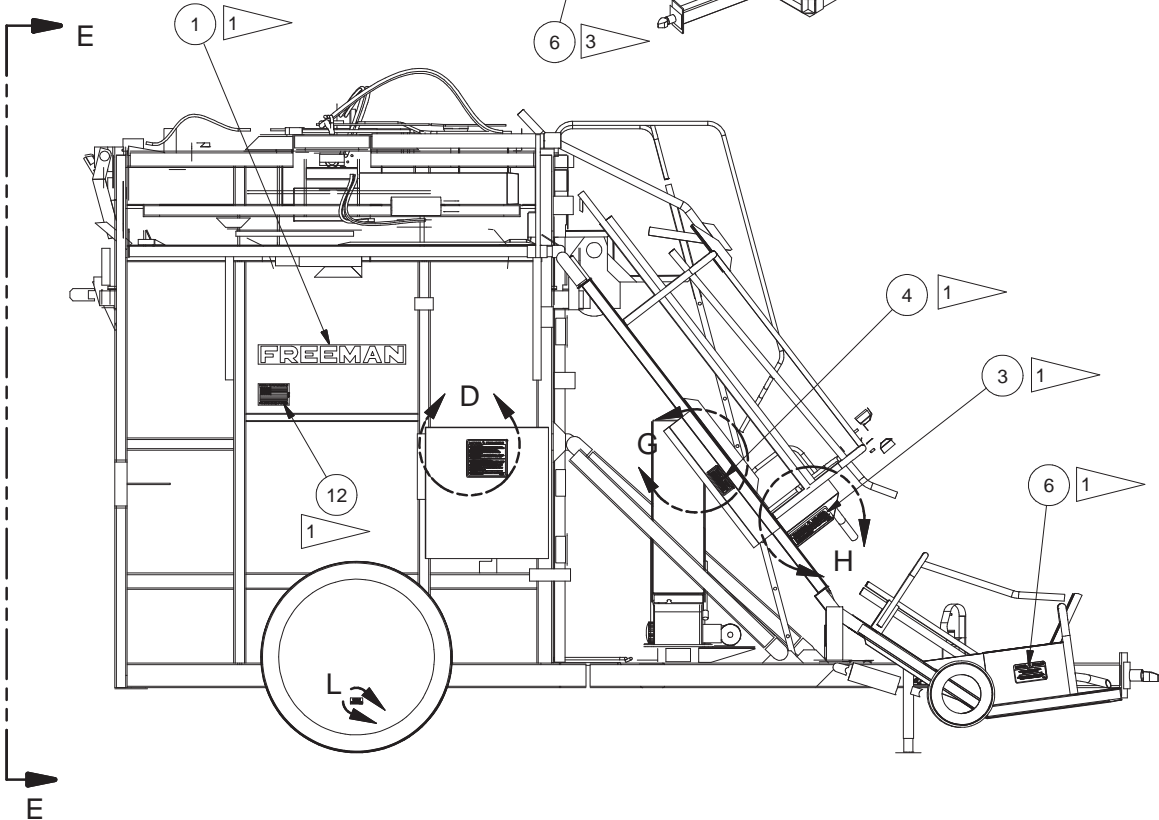
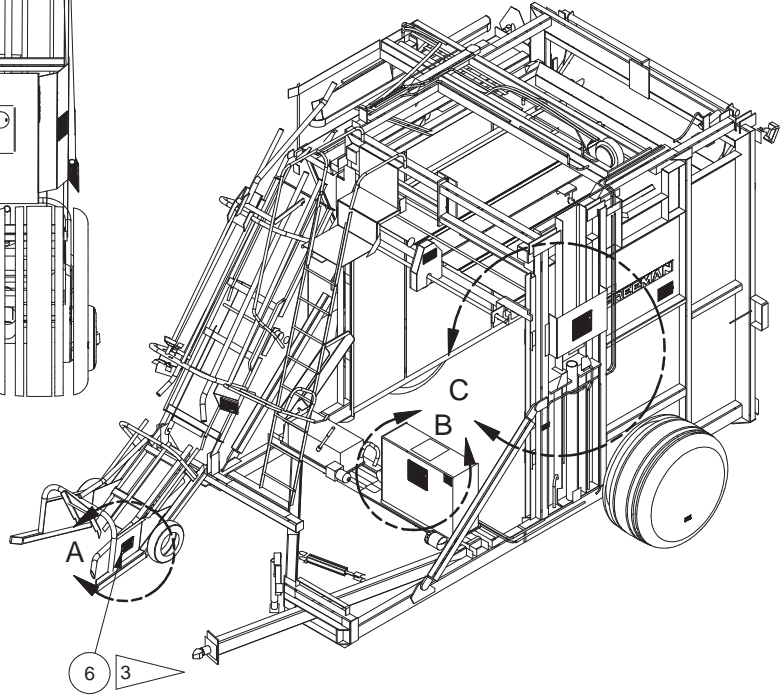

Decal Installation

Page 2 of 4

Item	Part No.	Qty	Description	Item	Part No.	Qty	Description
			904917	Decal Installation			
1	FD00007113	2	. Decal, Freeman, White	7	FD00034273	1	. Decal, Caution, Drawbar Jack...
2	FD00023473	3	. Decal, Caution	8	FD00000045	1	. Decal, Hydro Tank Oil Level
3	FD00023582	2	. Decal, Warning! Do Not Ride...	9	NP00000100	1	. Plate, Modle/Serial #
4	FD00023576	2	. Decal, Danger Look & Listen	10	FD00023894	1	. Decal, Keep Out From Under Bed
5	FD00023951	2	. Decal, Lug Nut	11	FD00007111	1	. Decal, Freeman, White
6	FD00023574	2	. Decal, Caution, Danger	12	FD70000434	2	. Decal, Manufactured In USA

Rev C

Decal Installation

Page 3 of 4

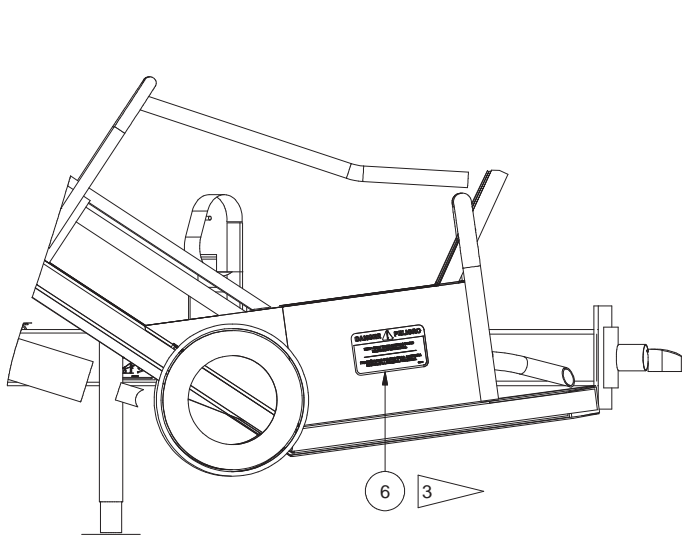

DETAIL A

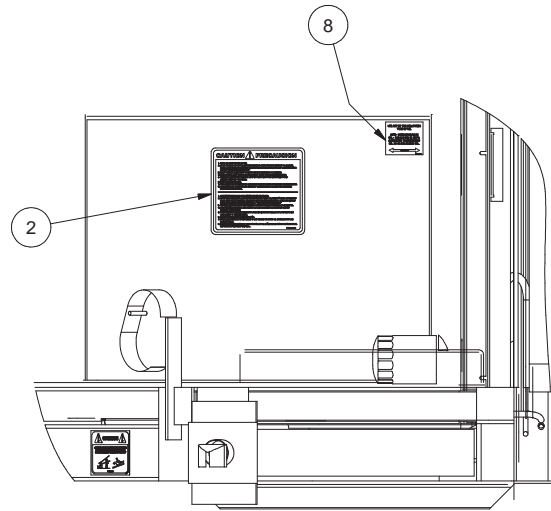

DETAIL B

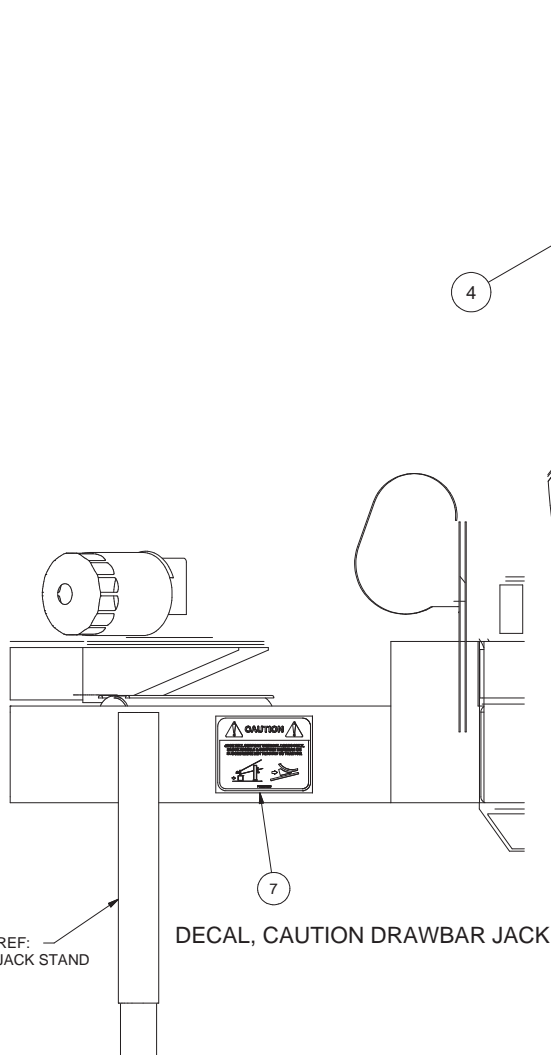

DECAL, CAUTION DRAWBAR JACK

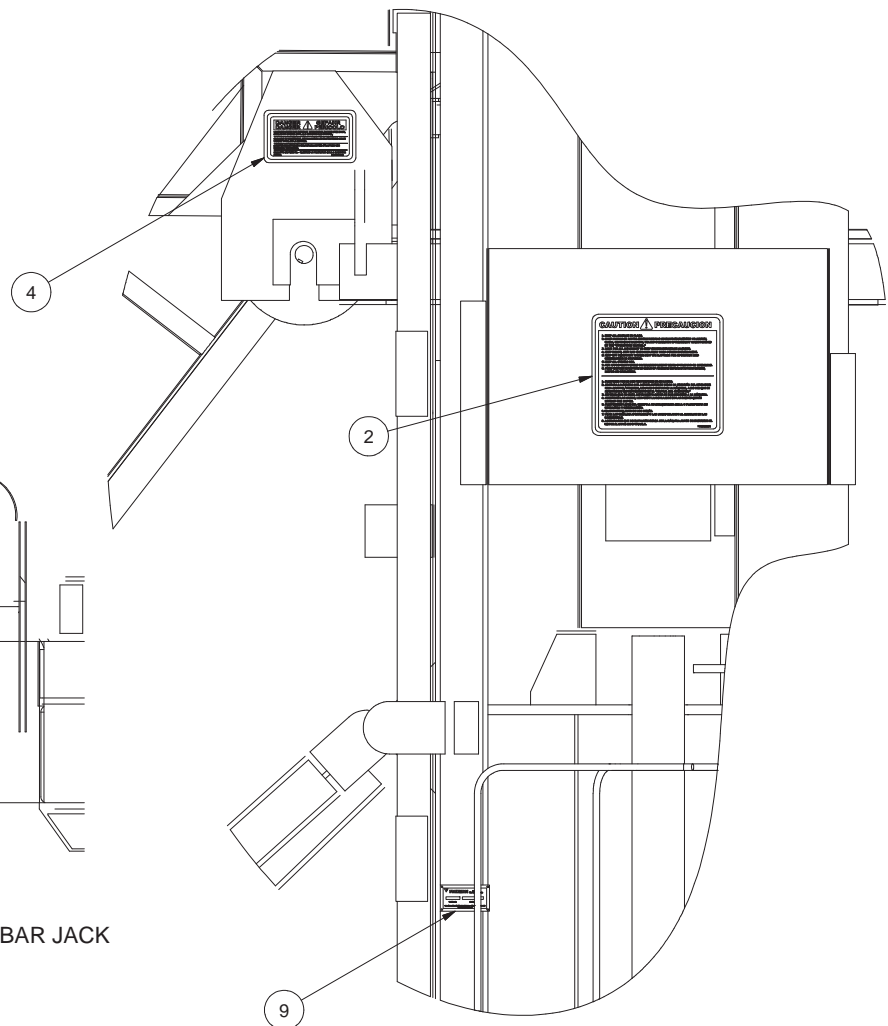

DETAIL C

Decal Installation

Page 4 of 4

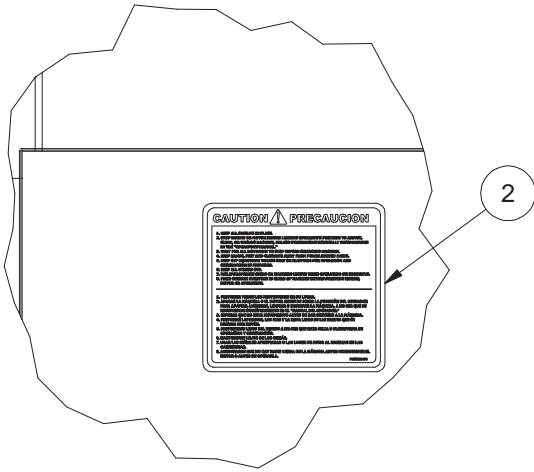

DETAIL D

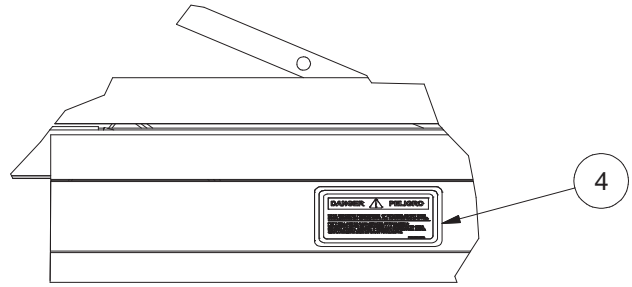

DETAIL G

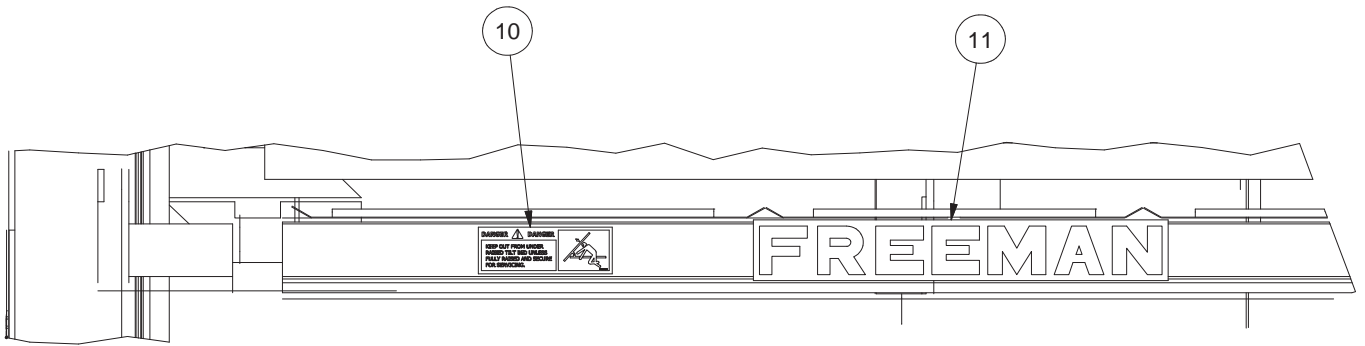

DETAIL F

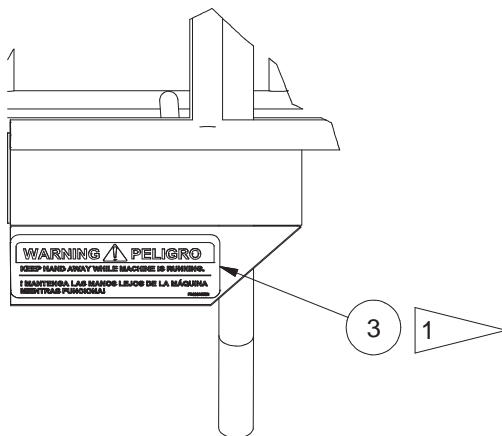

DETAIL H

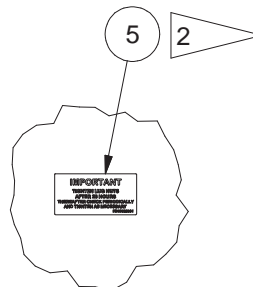

DETAIL L

Loose Ship Parts

Page 1 of 2

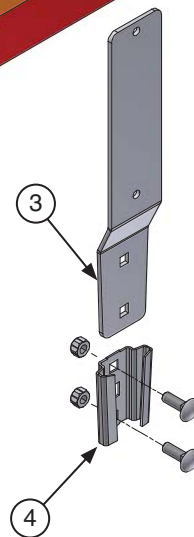
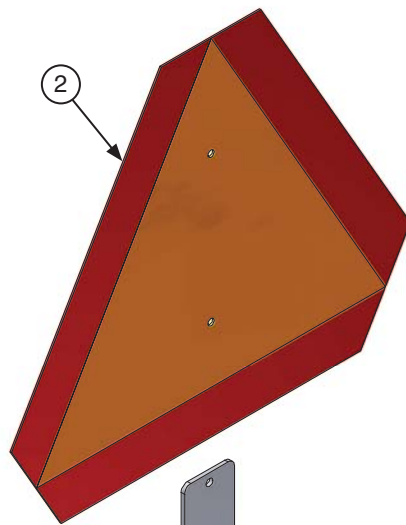
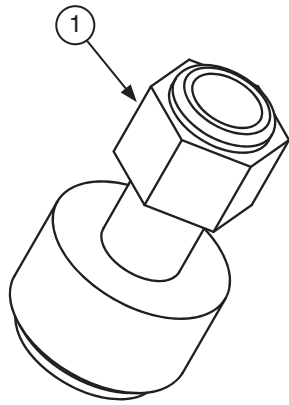

Loose Ship Parts

Page 2 of 2

Item	Part No.	Qty	Description	Item	Part No.	Qty	Description
	905101		Loose Ship Parts				
1	259170	1	. Hyd Test Port Gauge Adapter	3	BKT0000001	1	. Bracket, Slow Moving Vehicle Sign
2	SGN0024006	1	. Slow Moving Vehicle Sign	4	MNT0000001	1	. Sign Mounting Kit, W/ Hardware

Rev -

Parts Index

Part No.	Description	Page No.	Part No.	Description	Page No.
11767	Kit, Split Flange	85	236134	Seal Kit, Viton	77
12723	Seal	69	237822	Hose Assembly	85
14821	Fitting	85	238011	Fitting	85
17949	Fitting	85	241487	Hose Assembly	85
20294	Oxidation Inhibitor	67, 69	242101	Seal Kit, Buna	77
23945	Fitting	85	243356	Hose Assembly	85
48688	Key	23, 47	243815	Seal Kit, Buna	77, 93
207563	Seal	69	244001	Sequence Valve	77
209063	Fitting	85	244055	Relief Valve	77
209087	Fitting	85	244421	Hose Assembly	85
209151	Fitting	85	246037	Threadlock, Removable	9
209155	Fitting	75, 85	246143	Relay Socket	67
209164	Fitting	75	247151	Plate	85
209166	Fitting	85	250591	Cap, Dust	13
209181	Fitting	79	251394	Seal Kit, Buna	77
209202	Fitting	85	251960	Hose Assembly	85
209208	Fitting	75	252619	Relay, Main Power	67
209215	Fitting	93	253095	Switch, Rocker	69
209325	Hose Assembly	85	253243	Directional Control Valve	77
209409	Fitting	85	254706	Seal Kit, Buna	77
209411	Fitting	85	254837	Module, Expansion	65
209413	Fitting	85	255240	Adapter, Usb	67
209414	Fitting	85	255601	Seal Kit, Viton	77
209416	Fitting	85	256890	U-Bolt	111
209488	Fitting	85	257265	Follower, Cam	45
209490	Fitting	75, 85	257765	Cushion, Clamp	85
209699	Clamp	85	257810	Head, Filter	71
209703	Clamp	85	257830	Lid Support	65, 71
209714	Fitting	75	257833	Cover Plate	85
209715	Fitting	75	258627	Seal Kit	81
209758	Fitting	85	258704	Seal Boot	105
209805	Fitting	75, 85	258762	Flat Washer	43
210091	Fitting	85	258821	Seal	69
210732	Fitting	71	258826	Buzzer	69
211563	Fitting	71	258827	Gasket	69
212255	Cotter Pin	57	258858	Receptacle	67
214479	Seal	67	259170	Hyd Test Port Gauge Adapter	119
215036	Hose Assembly	85	259222	Hose Assembly	85
215203	Fitting	85	259223	Hose Assembly	85
217484	Fitting	85	259226	Hose Assembly	85
217647	Fitting	71	259227	Hose Assembly	85
220095	Fitting	85	259228	Fitting, Cable Gland	85
220353	Seal	69	259244	Filter Assy	75
220949	Mount, Adhesive Back	67, 69	259246	Needle Valve	77
221231	Fitting	85	259247	Logic Element	77
222470	Nut, Insert	69	259248	Directional Control Valve	77
222852	Fitting	71	259250	Relief Valve	77
223063	Circuit Breaker	67	259252	Counter Balance Valve	77
223377	Circuit Breaker	67	259255	Check Valve	77
223427	Flat Washer	85	259256	Check Valve	77
223784	Fitting	93	259257	Check Valve	77
225660	Fitting	79	259258	Seal Kit, Buna	77
225830	Fitting	85	259259	Seal Kit, Viton	77
226552	Fitting	85	259260	Seal Kit, Buna	77
226904	Fitting	85	259261	Seal Kit, Viton	77
229289	Toggle Switch	67, 69	259266	Solenoid Valve Assy	77
229345	Fitting	75	259267	Seal Kit, Buna	77
229641	Hose Assembly	85	259269	Seal Kit, Viton	77
230471	Seal	67	259274	Test Point	77
230839	Connector, Cord	67	259275	Solenoid Valve Assy	77
231044	Ring, Seal	67	901276	Bracket, Mounting	69
232862	Fitting	85	901521	Light Assembly, Work	111
232934	Fitting	85	902333	Paddle	103
234218	Jam Nut	63	902335	Mount	103
234230	Hose Assembly	85	902424	Bale Retainer Assembly	61, 63
236133	Seal Kit, Viton	77	902435	Index Paddle Assembly	97, 103

Parts Index Cont.

Part No.	Description	Page No.	Part No.	Description	Page No.
902442	Pickup Assembly	17, 19	904990	Decal	67
902443	Elevator Assembly	23, 27	904991	Decal	67
902488	Pivot	103	904992	Decal	67
902871	Roller, Cylinder Head	41	904993	Decal	67
904018	Tube	45	904996	Panel Assembly	65
904239	Plate, Mounting	47	904997	Limit Switch Assembly	43, 47, 105
904818	Shaft, LH Tie Arm	57	904999	Hinge	65
904819	Shaft, RH Tie Arm	57	905007	Bar	71
904820	Tie Arm, LH	57	905008	Frame, RH	9
904821	Tie Arm, RH	57	905020	Controller Assembly	65
904822	Tie Arm Installation	55, 57	905049	Mount	65
904832	Actuator Extention	47	905050	Bracket, Mounting	65
904833	Actuator Assembly	47	905065	Drawbar Receptical Box	11, 13
904834	Bale Table Installation	47	905068	Box Weldment	13
904837	Frame, LH	9	905069	Bracket	13
904855	Roller Mount Assembly	43, 45	905070	Pusher Assembly Installation	55
904856	Plate, Mounting	45	905071	Shield, Harness	43
904857	Plate, Mounting	43	905096	Bar, Mounting	47
904858	Actuator	43	905100	Sensor, Temp	71
904862	Bushing, Actuator	43	905101	Loose Ship Parts	119
904863	Limit Switch Instal, Push Off	31, 43	905103	Tube Assembly	71
904873	Frame, Bale Table	47	905107	Bar, Mounting	9
904874	Plate, Actuator	47	905132	Nipple, Pipe	79
904875	Plate, Trip	47	905149	Tube Assembly	85
904876	Plate, Mounting	47	905158	Fitting Assembly	85
904885	Pin	47	905159	Fitting Assembly	85
904891	Frame Assembly	9	905160	Fitting Assembly	85
904900	Wheel Installation	15	905168	Indicator	75
904901	Pickup Installation	17	905169	Filter Element	75
904902	Elevator Installation	23	905240	Spacer	11
904910	Limit Switch Installation	97	906167	Kit, Seal	85
904915	Lights Installation	111	906168	Switch Assembly, Limit (LS-13)	97, 107
904917	Decal Installation	115	906205	Seal	67
904922	Load Bed Installation	31	906439	Safety Gate	53
904924	Safety Gate Installation	53	906524	Hose Assembly	85
904936	Gasket	69	906538	Cylinder Assembly, Hydraulic	81
904937	Box, Control	69	906539	Hose Assembly	85
904938	Cover	69	906540	Hose Assembly	85
904939	Decal	69	906543	Support	9
904940	Control Box Assembly	69	906555	Tank, Hydraulic	79
904941	Switch, Limit	109	906557	Cover Plate	79
904942	Switch, Limit	109	906559	Tank Assembly, Hydraulic	71, 79
904943	Switch Assy, Limit (LS-5)	97, 109	906560	Gasket, Cover	79
904944	Switch Assy, Limit (LS-6, 7)	97, 103, 109	906561	Manifold & Tank Installation	71
904945	Switch Assy, Limit (LS-2, 3, 4, 12)	97, 109	906562	Hydraulic Instl, Hose & Tube	85
904946	Switch Assy, Limit (LS-10, 16)	97, 109	906564	Manifold	75
904947	Switch Assy, Limit (LS-11)	97, 109	906565	Manifold Assembly	71, 75
904948	Cylinder Head Assembly	31, 41	906586	Counter Balance Valve	77
904950	Bracket, Limit Switch	97	906588	Manifold Assembly	85, 93
904951	Wire Harness, Control Box	69	906589	Valve, Counterbalance	93
904952	Highway Light Harness	111	906590	Valve Body	93
904953	Plate, Cover	69	906593	Tube Assembly	85
904954	Gasket	69	906596	Hose Assembly	85
904962	Junction Box Assembly	65, 67	906598	Hose Assembly	85
904964	Box	67	906602	Hose Assembly	85
904965	Panel	67	906603	Tube Assembly	85
904968	Plate, Mounting	67	906604	Tube Assembly	85
904974	Bracket, Mounting	71	906605	Tube Assembly	85
904980	Cover, Manifold	71	906607	Tube Assembly	85
904981	Wire Harness, Junction Box	67	906609	Hose Assembly	85
904982	Switch Wiring Diagram	105, 107, 109	906665	Bale Retainer Installation	61
904985	Hitch	11	906674	Chain Roller, LH Mount	81
904986	Hitch Assembly	9, 11	906675	Chain Roller, RH Mount	81
904987	Decal	67	906677	Cylinder Installation	81
904988	Decal	67	906687	Hose Assembly	85
904989	Decal	67	906701	Chain Assembly	85

Parts Index

Part No.	Description	Page No.	Part No.	Description	Page No.
906943	Seal Kit	81	CLP0000130	Fastener, Hook Type	65
231997	Connector, Cord	109	CNK0002008	Link, Connecting	31
01-720	Nipple, Pipe	71	CNK0002060	Connecting Link	47
02-104	Flange Bearing	23, 47	CNK0002080	Connecting Link	31
02-115	Roller Bearing F/Main Mast	31	CNR0000193	Connector, Cord	105, 107
02-122	Grease Seal	15	COT0000503	Cotter Pin	15
02-125	Bearing Cup, Outer	15	CPL0010011	Coupling	23
02-126	Outer Bearing Cone	15	CPL0080104	Coupler, Male	85
03-158	Switch, Limit, With Seal Boot	105	CRN0000193	Connector, Cord	109
03-178	Repair Kit	105	CYL0000454	Hydraulic Cylinder	81
03-188	Indicator Lamp Base	69	CYL0004966	Cylinder Assembly, Hydraulic	81
03-189	Indicator Lamp Lens	69	CYL0009014	Cylinder Assembly	81
03-190	Indicator Lamp Bulb	69	CYL0017568	Hydraulic Cylinder	81
047-0229	Fitting	85	DRB0025843	Drawbar	11
05-214	Sprocket	31	DRW0016741	Plate, Mounting	9
07-123	Anchor Bolt Assembly, Chain	31	DRW0016773	Handrail, RH	53
10-144	Bale Check	19	DRW0016774	Handrail, RH	53
10-145	Pin	19	DRW0032308	Plate, Drawbar	81
11-258	Bracket	47	DRW0032639	Bushing	63
11-260	Pin	47	DRW0073259	Holddown Bar	19
14-104	Anchor Bolt, Mast Lift Chain	31	DRW0073291	Cylinder Head	41
14-107	Roller, Chain	31	DRW0073472	Pusher	57
15011W	Jam Nut	31	ELV0032327	Frame, Elev	27
16980W	Nut, O-Ring Fitting	85	ELV0073199	Tube	9
19-109	Valve Stem	15	ELV0073299	Hold Down Arm, Elevator	27
21-108	Lug Bolt	15	F000000172	Set Collar	19
21-179	Spindle Washer	15	F000000278	Spring, Tension	47
21-901	Hub Group, Complete	9	F000000323	Inner Bearing Cone	15
230351W	Bearing Cup, Inner	15	F000000747	Square Tip Rod Return Spring	19
ACT0073458	Plate, Trip Mount	47	F000000883	Idler Pulley	31
ARM0CH5001	Operator, Roller Type	107, 109	F000001549	Rod End, RH	57
ARM0CH5084	Operator, Roller Type	109	F000004104	Key	57
BAR0031490	Crowder Bar, Upper	27	F000004115	Spring, Ext	43
BAR0031491	Crowder Bar, Lower	19	F000005992	Male Rod End	57
BAR0073142	Lower Hold Down Bar	27	F000006170	Zerk	57
BAR0073224	Anchor Bar	85	F000006511	Cotter Pin	11
BAR0073287	Bar, Guide	31	F000006724	Cylinder, Hydraulic	81
BAR0073288	Bar, Guide	31	F000006727	Seal Kit	81
BAR0073345	Push Off Bar	31, 43	F000007607	Bearing, Inner Race	57
BED0073275	Bed	43	F000007904	Key	31, 57
BKT0000001	Bracket, Slow Moving Vehicle Sign	119	F000008000	Cap, Hub	15
BKT0034995	Bracket	111	F000008147	Bushing, Drive Rod	53
BKT0073077	Bracket	47	F000008264	Bumper, Rubber	27
BKT0073296	Bracket, LH	31	FD00000045	Decal, Hydro Tank Oil Level	115
BLT0073319	Tie Pivot Arm	57	FD00007111	Decal, Freeman, White	115
BRC7311600	Brace, LH	9	FD00007113	Decal, Freeman, White	115
BRC7311601	Brace, RH	9	FD00023473	Decal, Caution	115
BRG0001636	Top Roller Bearing	31	FD00023574	Decal, Caution, Danger	115
BRGRCJ1375	Flange Bearing	31, 57	FD00023576	Decal, Danger Look & Listen	115
BSH0000H10	Split Taper Bsh	23	FD00023582	Decal, Warning! Do Not Ride	115
CAM0016742	Plate, Cam	9	FD00023894	Decal, Keep Out From Under Bed	115
CBL0000114	2 Conductor Black Cable	105, 107, 109	FD00023951	Decal, Lug Nut	115
CHN0001390	Chain, Ag Safety	11	FD00034273	Decal, Caution, Drawbar Jack	115
CHN0032522	Table Chain Complete	47	FD70000434	Decal, Manufactured In USA	115
CHN0032748	Pickup Chain	17	FIL0010003	Cap, Filter	79
CHN0035045	Chain	31	FIL0023018	Element, Filter	71
CHN0035046	Chain	31	FLP0016778	Platform, Safety	53
CHN0035047	Chain	31	FRM0016910	Frame, Top Main	9
CHN0035048	Chain	31	GAG0064051	Gauge, Sight Level	79
CHN0035049	Chain	31	GRD0032406	Plate, Guard	9
CHN0035050	Chain	31	GUD0016919	Plate, Guide	47
CHN0035051	Chain	23	GUD0073016	Plate, Guide	31
CHN0035052	Chain	23	GUD0073511	Plate, Guide	47
CHN0073024	Pivot Mount F/Lift Chain	31	HAN0017239	Bar, Handle	65, 71
CHN0073055	Tightener, Bed Chain	31	HGR0016785	Hydraulic Hose Hanger	11
CHN0073228	Swivel, Chain	31	HOS0029730	Hose Assembly	85

Parts Index Cont.

Part No.	Description	Page No.	Part No.	Description	Page No.
HOS0032751	Hose Assembly	85	R740867	Seal, Wire	105, 107, 109
HOS0032754	Hose Assembly	85	R740874	Pin, Female	105, 107, 109
HOS0032755	Hose Assembly	85	R740886	Connector, Wire	105, 107, 109
HOS0032756	Hose Assembly	85	RAL0016777	Handrail, LH	53
HSP0000004	Hose Protector	85	REE0646040	Hose Reel	85
HTH0032715	Ball Hitch	11	RET0016912	Upper Bale Retainer	63
HUB0000348	Hub Assembly	19	RET0016913	Retainer, Lower	63
HYD5435050	Long Elbow	85	RET0073165	Tie-Tier Retainer, Front	9
HYD5525040	Blkhd Union Elbow	85	SEL0000454	Seal Kit	81
JCK0178203	Jack	11	SEL0310534	Seal Kit	81
KOB0000102	Knob	69	SELTC17568	Seal Kit	81
LAT0016809	Plate, Latch	53	SGN0024006	Slow Moving Vehicle Sign	119
LDR0016768	Ladder	53	SHD0016867	Shield Weldment	31
LEV0073189	Tie Arm Lever	57	SHD0032903	Plate, Shield	23
LEV0073196	Lever	57	SHF0032650	Shaft	23
LEV0073322	Front Pusher Tie Arm Lever	57	SHF0032651	Shaft	23
LEV0073323	Rear Pusher Tie Arm Lever	57	SHF0073076	Shaft	47
LIT037163B	Light Assembly, LH	111	SHF0073285	Shaft	31
LIT037164B	Light Assembly, RH	111	SHM0034535	Shim	55
LNK0073249	Plate, Link	81	SHM0073233	Shim	31
MLD7500317	Trim, Edge	65	SOK0000007	Boot	13
MNT0000001	Sign Mounting Kit, W/ Hardware	119	SOK0012310	Socket	13
MNT0016779	Plate, Top	53	SPC0017669	Spacer	55
MNT0016827	Pusher Guide Pad Mount	57	SPG0017227	Spring, Knockdown	27
MNT0016865	Cylinder Shaft Mount	81	SPG0073238	Spring	27
MNT0016868	Cylinder Base Mount Assembly	81	SPK0008039	Sprocket	19, 23
MNT0017140	Pusher Cylinder Rod Mount	55	SPK0025111	Sprocket	23, 47
MNT0025269	Bar, Retain	61	SPK0060048	Sprocket	31
MNT0032340	Plate, Sprocket	19	SPK0060154	Sprocket	31
MNT0032737	Bar, Mounting	27	SPK0060172	Sprocket	47
MNT0032745	Mount, Elevator Motor	27	SPK0073349	Sprocket	31
MNT0032787	Mount	47	SPN0025350	Pickup Wheel Spindle	19
MNT0032794	Bracket, Mounting	47	SPN0032649	Spindle	15
MNT0032804	Plate, Mounting	47	SQS3751500	Setscrew	81
MNT0035151	Bed Roller Mount	31	SQS5004000	Set Screw	31
MNT0073135	Pipe Bushing Mounts	27	SQS5004500	Set Screw	63
MNT0073145	Elevator Upper Mount - Slotted	23	SRP0016794	Pad, Wear	57
MNT0073294	Plate, Mounting	97	STR0073341	Bar, Support	81
MNT032804	Mounting Plate	47	SUP0032395	Pickup Bale Guide Support	19
MTR00RSAK1	Motor, Hydraulic	23, 47	SUP0073075	Angle, Support	47
MTR1041026	Motor, Hydraulic	31	SUP0073512	Support, Front	47
NCC0001000	Castle Nut	31	SWI0000004	Switch, Push Button	69
NFC0008750	Castle Nut	15	SWI0000007	Switch, Rocker	69
NMS0000109	Conduit Locknut	67	SWI0000008	Switch, Rocker	69
NP00000100	Plate, Modle/Serial #	115	SWI0CH5079	Switch, Limit	107, 109
NSL0001000	Nut, Castle	57	TIR2151614	Flotation Tire	15
PCY0032354	Frame, Pickup	19	TRK0016931	Track, Bale Table Chain	47
PIN0011337	Clevis Pin	81	TRK0032322	LH Pick-Up Chain Track	19
PIN0026531	Pickup Pivot Pin	23	TRK0032325	RH Pick-Up Chain Track	19
PIN0033525	Bed Lift Roller Pins	31	TRK0032652	Track, Lower Elevator Chain	27
PIN0033547	Pin, Cylinder Head	41	TRK0032653	Track	27
PIN0073342	Pin	11	TRK0073201	Plate, Roller Track	9
PIN0073343	Pin	11	TUB0035010	Tube Assembly	85
PLT0073227	Bar, LH Rear	31	TUB0035014	Tube Assembly	85
PLT0073376	Plate, Reinf	9	TUB0035023	Tube Assembly	85
PMP0000001	Pump, Hydraulic	85	TUB0035035	Tube Assembly	85
PPE1250401	Nipple	71	TUB0035036	Tube Assembly	85
R12578057	Fitting	85	TUB0035037	Tube Assembly	85
R12973037	Seal Kit, Viton	77	VLV0002005	Ball Valve	71
R13802633	Flat Washer	19	WHL 1 8493	Wheel	15
R13803393	Fitting	85	WHL0053579	Tire & Wheel Assy	15
R13806990	Flat Washer	81	WHL0401530	Wheel & Tire Assembly	19
R13807508	Fitting	85	ZZ00000206	Mach Bushing	57, 61
R13809570	Jam Nut	31	ZZ00000428	Key	31
R13811447	Flat Washer	103	ZZ00002016	Set Collar	47
R4510197	Relay, Work Lights	67			



To find a dealer in your area,
Call: 503-625-2560,
Fax: 503-625-7269, or
Visit our website: <http://www.alliedsystems.com>

Allied Systems
C O M P A N Y

PB00700014 1/26/2015
Printed in USA