

Hang-On Block Handlers

- Adapt ITA carriage to double and single block handling
- Full floating forks severely minimizes block damage
- Sideshifting option, allows precise positioning to pickup and deposit blocks

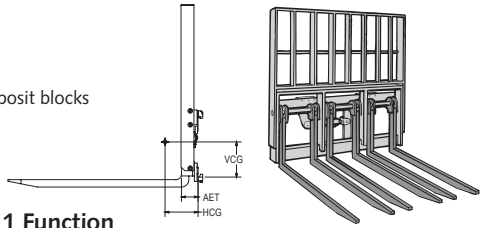

Single Block Handler Models with Load Backrest, 1 Function

Model Number	Capacity lb @ 24"	Mounting Class	Overall Width (in)	Min. Truck Carriage Width (in)	Cube Width (in)	Total Sideshift (in)	Lost Load AET (in)	HCG (in)	VCG (in)	Weight (lb)
JBSC090B500	9,000	III	50	40	48/54	8	2.9	10.9	11.3	885

Recommended Hydraulic Supply

Model Number	Flow (gpm)	Recommended psi
All block handlers	3-6	2,000-2,500

Hydraulic flow less than minimum may reduce operating speed and/or cause irregular arm movement. Higher flow may result in heat build-up, erratic operation and shortened hydraulic system life.

Important Notes

- Single block handlers include six block-saver forks (2" T x 1.5" W x 47" L)
- Double block handlers include 12 block-saver forks. Call for other sizes.
- Lock collars included to control spacing of forks.
- Solid bronze slide top hooks; no-lube heel rollers.
- Replacement forks are available; see pages K-2 through K-5 for standard and specialty forks.

Double Sideshifting Block Handlers

- Designed to handle a double cube of both 16" and 18" cement blocks
- Popular, durable top linear bearing and hardened steel heel rollers
- Includes 48" load backrest, 12 block forks and locking collars

Pin Type, 2 Functions

Model Number	Capacity @ 24" (lb)	Overall Width ¹ (in)	Single Width ² (in)	Shift Each ³ (in)
TBSA110P4815	11,000	100	50	15
TBSA150P4815	15,000	100	50	15

¹ Overall width is with sideshifters touching in the center of the base carriage and includes load backrests. Maximum overall width is 118".

Block fork dimensions are 2" thick x 1.5" wide x 47" long.

² Block handler includes load backrest and forks.

³ Each sideshifter shifts 6" over center.

⁴ Prices do not include carriage rollers.

Important Notes

- Sideshift cylinders are unholed. Installation will require hoses to cylinders for either simultaneous or independent sideshift. Other hoses options available. Consult factory.
- Horizontal and vertical center of gravity dimensions will be determined and provided at the time of order. These dimensions are dependent on the specific forklift and mast into which the integral unit will be installed.

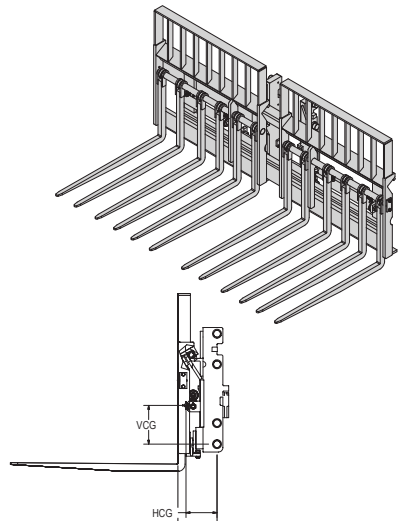

Recommended Hydraulic Supply

Model Number	Recommended Flow (gpm)	Recommended psi
All models	8-10	2,000-2,500

Hydraulic flow less than minimum may reduce operating speed. Higher flow may result in heat build-up, erratic operation and shortened hydraulic system life.