

FREEMAN



Best in the field.

The Freeman Model 1592 Big Baler, Big Bales - High Capacity

High Capacity with Less Time Spent in the Field

The Freeman 1592 Big Baler is a big performer, redesigned for 25% greater capacity. The versatile 1592 can bale up to 45 tons per hour, and take on your toughest jobs of baling, including biomass, alfalfa, straw, coastal Bermuda, Sudan, haylage, or cornstalks.

The time saving features of the exclusive hydraulic drive system include the use of hydraulic relief valves instead of shear bolts to protect the baler. The hydraulic drive feed system is reversible from the tractor seat, saving hours of hand work unplugging a baler

The state-of-the-art hydraulic drive system has fewer moving parts than gear driven big balers. This feature, in addition to the traditional rugged Freeman baler construction, means that your annual repair, maintenance, and equipment replacement costs are lower. Features of the Freeman 1592 Big Baler ensure that you can reliably get more hay baled in less time than any other big baler available.



The Big Baler takes on your toughest baling jobs.



Original hay quality is preserved.

Gentle on Hay

The hydraulic drive 1592 Big Baler preserves original hay quality better than gear-driven balers. The hydraulic drive system ensures that hay flows freely from the windrow through the feed chute directly into the bale chamber, without the use of a pre-compression chamber.

The only time the hydraulically driven bale plunger operates is when the bale chamber is fully charged. This design feature:

- Gives you 17-22 uniform bale flakes per 8 foot bale,
- Protects alfalfa and other fragile crops,
- Makes feeding easier - bales break apart readily and controllably.

The 1592 Keeps Baling Costs Down, Profit and Production Up



Uniformly square and solid big bales.

Ideal Bale Size

The 1592 Big Baler makes the ideal bale, in size and weight, for economic handling and hauling. The solid 38 by 46 inch six-tie bale provides a stable foundation, for dependable and sturdy winter storage stacks. It also permits loading one-third more big bales onto a standard flat bed truck than does 4 foot by 4 foot big bales.

These big uniform bales range in weight to over 1,100 pounds for straw and over 1,500 pounds for alfalfa hay. These bale weights can be easily handled with loader tractors with as little as 75 horsepower.



The ideal bale size for maximum pay loads.



Pick up and stack over 60 tons an hour.

Economical and Efficient Bale Handling

At stacking time, the Freeman Model 5300 Big Bale Roadsider will pick up big bales in the field and stack at the roadside at a rate of over 80 bales an hour. The Freeman 1592 Big Baler and the 5300 Big Bale Roadsider are the most cost effective and labor saving big bale system available.

Work Saving Features

Built-in work-saving features of the rugged 1592 Big Baler include the reversible feed system and the time saving use of hydraulic relief valves instead of shear bolts. These features ensure more baling time when the hay is ready, and more production over the whole season.

Long-lasting and reliable, the hydraulic plunger drive system eliminates troublesome high-wear plunger chains, sprockets, gears, and gear boxes.

For convenient maintenance and service the side shields swing out of the way. The operator can use a remote control system to operate the knotters, feed fork, and plunger independently for making adjustments to the baler. These features provide a safer working environment, and a quick and easy way to service the 1592 Big Baler

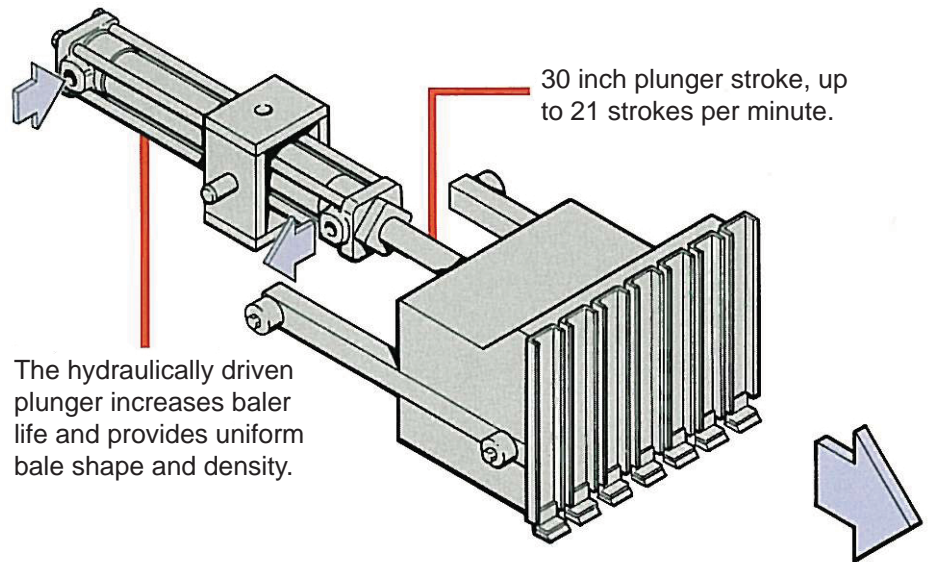

Plunger strokes only when bale chamber is fully charged.



Daily maintenance and service in just minutes.

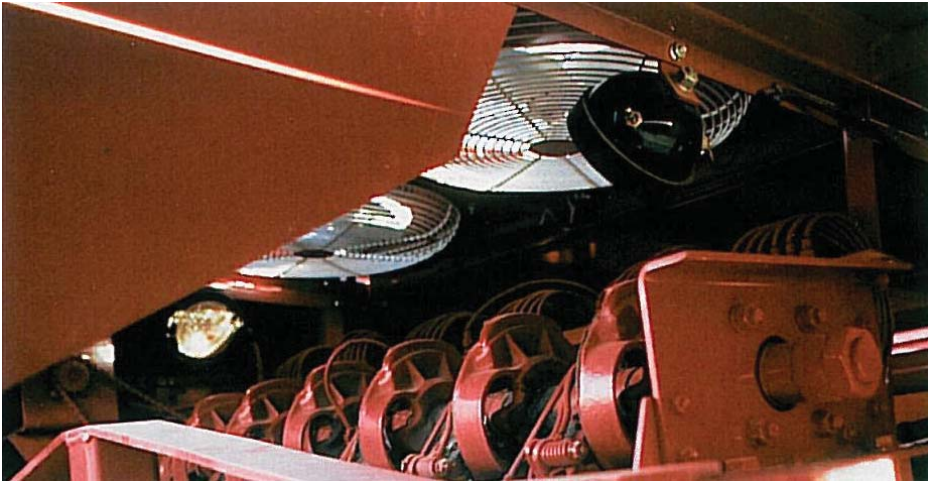

Fans over the knotters keep area clean for easier inspection and field service.

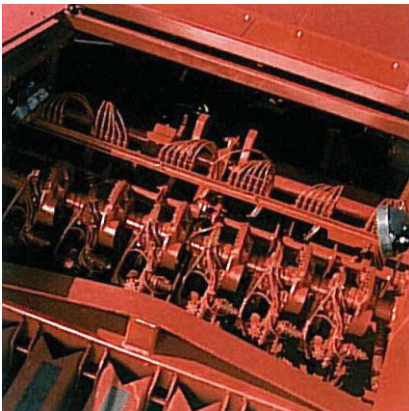

Automatic oil lubrication for the knotters.

The six heavy-duty knotters tie one knot per bale twine, not two knots. Fewer knots mean less knotter wear and less chance of missed ties. Knotter ties are monitored by an electrical knot sensor, using sensor lights visible from the tractor seat to signal a missed tie. These knotters are designed for dependable service in all baling conditions.



The tension control system uses four hydraulic rams to control bale density.

The automatic knotter lubrication system, standard on every Big Baler, oils each knotter wear point each time the knotter ties. This automatic lubrication system reduces knotter wear and daily maintenance time.

Dual knotter fans are optional for excessively dusty baling conditions. The knotter fans keep the knotter area clean, for easier inspection and service while also preventing missed ties due to chaff build-up around the hay dogs and knotters.

The 1592 Big Baler's hydraulic tension control system automatically controls bale density and shape by applying even pressure to the bale sides and top. Bale length is selected with an easy to operate spring-loaded adjuster. The bale length metering system and automatic tension control produces bales of uniform length and density in varying crop conditions from alfalfa to haylage.

Work lights and signal lights are standard for nighttime operation.

The Full Line of Hay Handlers ...



Pull Type Balers 2 or 3 Tie



Self Propelled Balers 2 or 3 Tie



Model 7000 Pull Type Bale Wagon



Model 8000 Bale Wagon



Model 1592 Big Baler



Model 5300 Big Bale Roadsider

SPECIFICATIONS

General

Working Length w/Bale Chute: 30 feet (9.144m)
Working Width: 10 feet (3.048m)
Working Height: 9 feet 8 inches (2.95m)
Shipping length, less Bale Chute: 23 feet 5 inches (7.137m)
Shipping width, without wheels and wheel spindles: 8 feet (2.44m)
Shipping height without wheels: 8 feet 10 inches (2.69m)
Tire size: 23.1 x 26 (12 ply)
Weight: 20,900 pounds (9480 kg)
Baler Capacity: Up to 45 Tons per Hour

Bale Chamber

Height: 38 inches (0.965m)
Width: 46 inches (1.17m)
Bale Length: Adjustable up to 9 feet (2.74m)
Bale Weight: Up to 1600 lbs (726kg)
Optional Chamber Sizes Available: 36 inch by 46 inch or 34 1/2 inch by 46 inch

Pickup

Working width: 80 inches (2.03m)
Including 6 inch flare on each side: 92 inches (2.34m)
Pickup drive system: Hydraulic drive
Protection: Slip and overrunning clutches
Pickup lift: Hydraulic cylinder

Feed System

First feeder crank: Three-throw crank
Feeder crank bearings: Six tapered roller bearings (relube)
Feeder crank drive system: Reversible hydraulic drive
Feed fork drive system: Reversible hydraulic drive

Plunger

Speed: Up to 21 strokes per minute
Length of stroke: 30 inches (0.762m)
Plunger drive system: 4 inches (10.16cm) bore hydraulic cylinder

Main Drive

PTO speed: 1000 rpm
Drive protection: Overrunning and slip clutches and hydraulic pressure relief valves
Hydraulic pump capacity: 80 gallons per minute
Oil cooler: Heavy duty radiator with automatic reversing electric fan

Tying Mechanism

Knotters: Six heavy-duty twine knot-ers (Standard, Double or Tail-less)
Knotter spacing: 7 inches (17.78cm)
Knotter lubrication: Automatic oil lubrication system
Twine storage capacity: 18 balls
Twine type: Plastic 300 to 450 pound knot strength

Bale Chamber Tension Control

Type: Automatic hydraulic tension control
Tension system: Top and sides squeeze, using four hydraulic cylinders

Tractor Requirements

Horsepower: 140 hp or greater to PTO recommended
Hydraulics: Single remote, pickup lift
Electrical: ASAE 7-pin connector outlet

To find a dealer in your area,
Call: 503-625-2560,
Fax: 503-625-7269, or

Visit our website: <http://www.alliedsystems.com>

FREEMAN
A Division of Allied Systems Company