

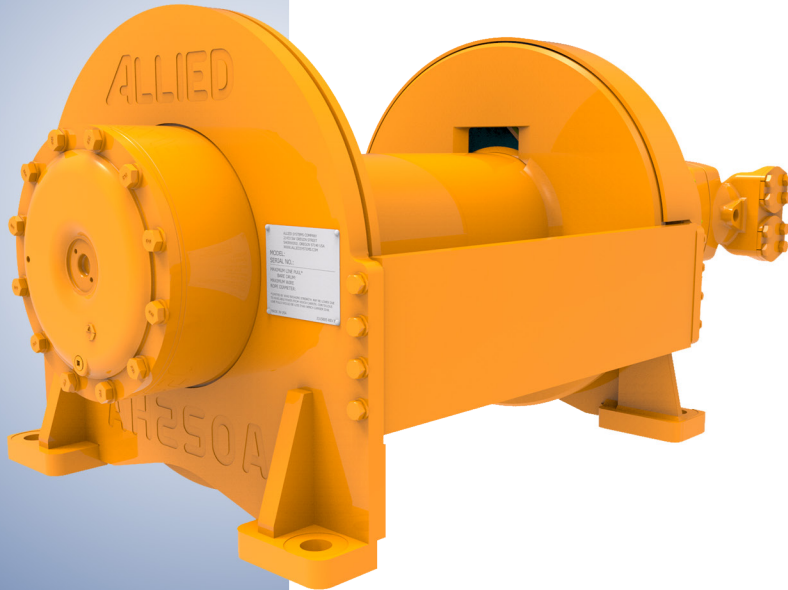

Parts Manual



Allied AH250A Hydraulic Winch

Please check the Allied Systems website regularly for updates to this manual.
www.alliedsystems.com

CUSTOMER EDITION

A PRODUCT OF

Allied Systems
COMPANY

SHERWOOD, OREGON USA

P/N 599065W

Printed in U.S.A.

04/17/2017

Safety Precautions

**Read, understand and observe the Safety Summary
on pages 0-3 through 0-5
to prevent injury to personnel and damage to equipment.**

Winch serial number _____

Date put into service _____

**NOTE: This publication may be translated to different languages for sole purpose
of easy reference in non-English speaking locations.
Should there be differences in interpretations to the text,
please refer to the English language edition published by Allied Systems Company
as the controlling document.**

Index

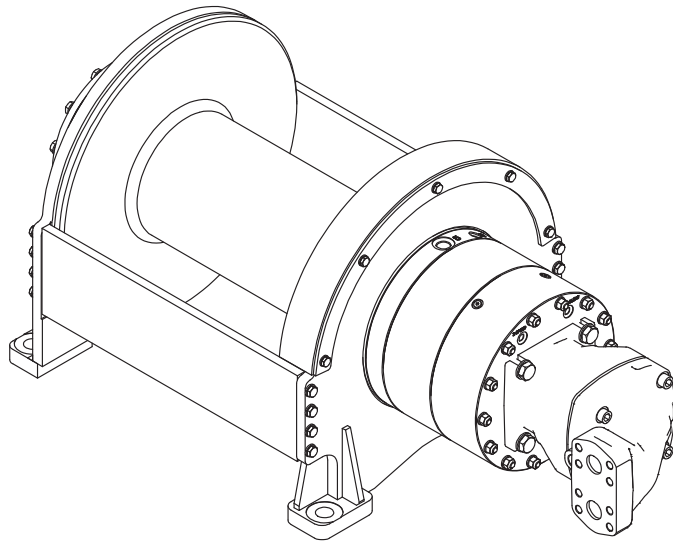

Ref	Item	Page
1	Winch Parts	1-1
2	Suggested Spares Guide	2-1

Safety Summary

General Safety Notices

The following pages contain general safety warnings which supplement specific warnings and cautions appearing elsewhere in this manual. All electrical and hydraulic equipment is dangerous. You must thoroughly review and understand this Safety Summary before attempting to operate, troubleshoot or service this winch.

The following symbols and terms are used to emphasize safety precautions and notices in this manual:



DANGER

The “DANGER” symbol indicates a hazardous situation which, if not avoided, will result in serious injury or death. Carefully read the message that follows to prevent serious injury or death.



WARNING

The “WARNING” symbol appears wherever incorrect operating procedures or practices could cause serious injury or death. Carefully read the message that follows to prevent serious injury or death.



CAUTION

The “CAUTION” symbol appears where a hazardous situation which, if not avoided, could result in minor to moderate injury and equipment damage.

NOTICE

This signal word alerts to a situation that is not related to personal injury but may cause equipment damage.

NOTE: ...

The term “NOTE” highlights operating procedures or practices that may improve equipment reliability and/or personnel performance.

NOTE: All possible safety hazards cannot be foreseen so as to be included in this manual. Therefore, you must always be alert to potential hazards that could endanger personnel and/or damage the equipment.

Safety Regulations

Each country has its own safety legislation. It is in the operator’s own interest to be conversant with these regulations and to comply with them in full. This also applies to local bylaws and regulations in force on a particular worksite.

Should the recommendations in this manual deviate from those in the user’s country, the national regulations should be followed.

Operation, Inspection, and Maintenance Warnings



WARNING

Obey the following cautions and warnings before using your winch to avoid equipment damage, personal injury or death.

- Do not operate the winch unless you are authorized and trained to do so.
- Do not operate the winch unless the machine is equipped with a screen to protect the operator if the wire rope breaks.
- Read, understand, and follow the operating, inspection, and maintenance instructions in this manual.
- Do not use the control levers for hand holds when entering or leaving the machine.
- Do not permit other people near the control area when you inspect or repair a machine.
- Never inspect, repair, or perform maintenance on a machine that is in motion.
- Inspect the winch before each use:
 - » Make sure that the controls and instruments operate correctly.
 - » Report the need for repairs immediately.
 - » Do not work with a damaged or worn wire rope.
 - » Do not use a winch that needs repairs.

- » Should the wire rope be removed from the drum, make sure the end of the wire rope is controlled when released. The end of the wire rope can suddenly move from the drum like a compressed spring when released and cause an injury.
- Stay in the operator's seat when operating the winch.
- Do not stand on the machine when operating the winch.
- Avoid winch operation near people or other machines.
- Never stand nor permit others to stand in the bight (loop) of a wire rope.
- Do not stand nor permit others to be near the winch or wire rope when there is tension on the wire rope.
- Observe jobsite rules.
- Be in complete control at all times.
- Do not use the control levers as hangers for clothes, water bags, grease guns, lunch pails, etc.
- Do not leave the machine when the winch wire rope is under tension.
- Do not permit riders on the machine or load.
- Do not use the winch as an anchor for a double or two-part line.
- Do not pull the hook through the throat or over the drum, which will cause damage.
- When the winch is not in use, make sure the control lever is in **BRAKE-ON** position and the winch brake is applied.
- Do not use winch as a hoist.
- Always inspect wire rope, tail chain and other rigging components for wear, damage, broken strands or abuse before use.
- Never use wire rope, tail chain or other rigging that is worn-out, damaged or abused.
- Never overload wire rope, tail chain or rigging.
- Wire rope and tail chain will fail if worn-out, overloaded, misused, damaged, improperly maintained or abused. Wire rope or tail chain failure may cause serious injury or death!
- Do not terminate wire rope to tail chain by the use of a knot.
- Do not handle wire rope if the hook end is not free. A load could break away, suddenly tensioning the wire rope, resulting in serious injury or death.
- Stay clear of wire rope entry areas.



- Make sure ground personnel are in plain view of the operator, and at a distance of at least 1½ times the working length of the wire rope.
- Make sure that any hand signals used by ground personnel are clearly defined and understood by everyone involved.
- Do not attempt to “jerk” or “shock” a load free. Doing so can cause loads in excess of the rated capacity of the wire rope, winch, or mounting hardware.
- Replace any parts only with genuine Allied Winch parts.
- Maintain a **minimum of three (3) complete wraps of wire rope** on the drum for normal operation. It may help to paint the last five wraps of wire rope a contrasting color, to serve as a visual indicator.
- Do not handle wire rope with bare hands. Wear leather gloves at all times.
- Align the machine with the load to prevent side loading the winch, and to maintain even spooling of the wire rope.
- If applying tension to the wire rope manually during spooling:
 - » ensure that the operator is winching in slowly,
 - » keep your hands and clothing well clear of any rollers or the winch drum,
 - » do not maintain tension by letting the wire rope to slip through your hands,
 - » use a hand-over-hand technique to maintain tension.
- Be aware of the ground conditions, and make sure the ground and machine are stable enough to pull the intended load.
- Do not attempt to pull loads in excess of the rated capacity of the winch.
- Keep yourself informed of any applicable codes, regulations and standards for the job.
- This winch is neither intended, designed, nor rated for any application involved in the lifting or moving of personnel.
- Use only the lubricants listed in the Recommended Oil List. See page 0-9.
- Do not weld on any part of the winch. Contact Allied Systems if weld repairs are needed.
- The hydraulic system must be kept clean and free of contamination at all times.
- Be aware of the hazards of pressurized hydraulics:
 - » Wear personal protective equipment, such as gloves and safety glasses, whenever servicing or checking a hydraulic system.
 - » Assume that all hydraulic hoses and components are pressurized. Relieve all hydraulic pressure before disconnecting any hydraulic line.
 - » Never try to stop or check for a hydraulic leak with any part of your body; use a piece of cardboard to check for hydraulic leaks.
 - » Small hydraulic hose leaks are extremely dangerous, and can inject hydraulic oil under the skin, even through gloves.



DANGER

Injection hazard.

Infection and gangrene will result when hydraulic oil penetrates the skin. See a doctor immediately to prevent loss of limb or death.

Use a piece of cardboard to check for hydraulic leaks.



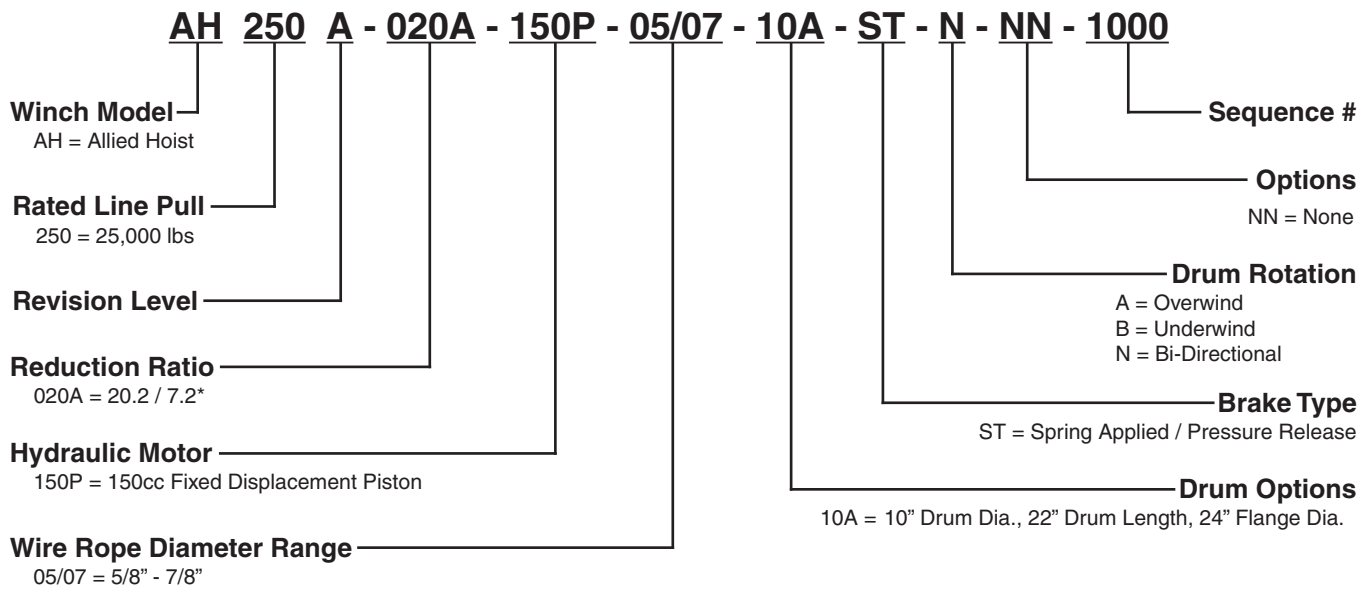

Serial Number Codes

The serial number codes are described above. The nameplate with the serial number code is found on the planetary side of the winch case. The serial number code is also stamped on the top of the planetary side of the winch frame.

Nameplate

Each winch is shipped from the factory with a nameplate as shown in Figure 1. The nameplate is stamped with:

- winch model
- winch serial number
- maximum bare drum line pull
- maximum wire rope diameter

DO NOT operate the winch with larger diameter wire rope. If the nameplate is missing, DO NOT operate the winch until its capacity is known.

The serial number for the winch is also stamped into the winch frame.



Figure 1-2 Nameplate

When the part number and the next higher assembly are not known:

1. Determine the function and application of the part required. Turn to the illustrated index page immediately behind the front cover, and select the most appropriate area.
2. Use the table of contents at the beginning of each chapter to determine the assembly which would normally contain the part required. Proceed then to locate the part on the assembly breakdown page.

When the part number is not known and the next higher assembly is known:

1. Determine the assembly the required part is used on. Turn to the master index (which immediately follows the illustrated index).
2. Locate the assembly on which the required part is used, and turn to the page indicated for that assembly. Proceed to locate the part on the assembly breakdown page.

When the part number is known:

Use the numerical index to find the part number. Turn to the page listed and locate the part as indicated by the reference number.

General:

The assembly breakdowns include part numbers, descriptions, quantities required, keys and footnotes to help in selecting the correct parts.

Keys are used to show effective serial numbers for two or more similar assemblies, LH and RH assembly parts, etc. Select the appropriate key, "A," "B," "C," or "D" and the corresponding quantity column to find the required parts.

Indent dots are used to indicate assemblies and sub-parts of assemblies. A part without a dot indicates a major assembly. Part descriptions which are indented with dots are sub-parts of the major assembly shown above.

Quantities shown are for one assembly. Note that when two assemblies are shown, but the quantity of the sub-parts is indicated as three, this means three per assembly - for a total of six. AR means As Required, and NSS indicates Not Sold Separately.

Serial numbers are shown to allow for the most current parts information to be incorporated into the parts manual. See page 0-6 for serial number information.

Abbreviations

Abbreviations are used both on the winch and in this manual. For example, a manifold may have a port stamped "FS". That port is related to the "freespool" circuit. This abbreviation is also used on pages in this manual that reference this port, or the ports connected to this port. Figure 2 lists the most common abbreviations used in this manual.

Abbreviation	Full Name
P	Pressure
T	Tank
BO	Brake Off
FA	Filter Outlet
FE	Filter Inlet
FS	Freespool
HS	High Speed
LS	Load Sense
PD	Pilot Drain
PP	Pilot Pressure
PS	Pilot Supply
RI	Reel In
RO	Reel Out
TP	Test Port
TS	Temperature Switch

Figure 2 - Abbreviations

Oil Specifications

Oil Selection

The main consideration while selecting hydraulic fluid is the estimated oil temperature extremes that will be experienced during service so the most suitable temperature-viscosity characteristics are obtained.

VISCOSITY GRADE		OIL OPERATING TEMPERATURE RANGE		TYPICAL AMBIENT TEMPERATURE RANGE	
ISO	SAE	°F	°C	°F	°C
VG 22	10W	-5 to 140	-20 to 60	-5 to 40	-20 to 4
VG 32	15W	10 to 160	-12 to 71	10 to 55	-12 to 13
VG 46	20	20 to 180	-7 to 82	20 to 70	-7 to 21
VG 68	20	30 to 200	-1 to 93	30 to 90	-1 to 32
VG 100	30	40 to 220	4 to 104	40 to 110	4 to 43

Figure 3 - Oil Selection Chart

Hydraulic Specifications

Motor 150cc Piston fixed displacement
 Brake Wet, multi-disc, spring applied, pressure released
 Clutch Wet, multi-disc, pressure applied, spring released

Oil Specifications

Recommended Oils* - General Conditions			
Manufacturer	Oil Type	Ambient Temperature Range	
		°F	°C
ExxonMobil	Mobil Fluid 424 (Factory fill)	-13 to 105	-25 to 43
John Deere	Hy-Gard™	-13 to 122	-25 to 50
Chevron	1000 THF	-13 to 105	-25 to 43
Caterpillar	Multipurpose Tractor Oil (MTO)	-13 to 104	-25 to 40
Case	Hy-Tran Ultra	-20 to 122	-30 to 50

Recommended Oils* - Low Temperature Conditions			
Manufacturer	Oil Type	Ambient Temperature Range	
		°F	°C
ExxonMobil	Mobil Fluid LT	-40 to 86	-40 to 30
John Deere	Low Viscosity Hy-Gard	-40 to 86	-40 to 30
Chevron	THF W	-40 to 86	-40 to 30

* Note: Use of non-recommended oils may void warranty.

Figure 1-4 Oil Specification

Oil Capacity

The oil capacity for the AH250A winch is 5 gallons (19 liters).



The winch oil should never exceed the maximum operating temperature of 239°F (115°C), as overheating will cause winch damage.

Ordering Parts:

When ordering replacement parts, give the unit serial number, part number, name of part and quantity required.

For any further information on parts, service or ordering, consult your local winch dealer, or contact Allied Systems Company:

Allied Systems Company
21433 SW Oregon Street
Sherwood, OR 97140 U.S.A.

Phone: 503-625-2560
Fax: 503-625-5132
E-Mail: parts@alliedsystems.com

Also see our website, www.alliedsystems.com, where the most current copy of this manual is always available.

NOTE: This publication may be translated to different languages for sole purpose of easy reference in non-English speaking locations. Should there be differences in interpretations to the text, please refer to the English language edition published by Allied Systems Company as the controlling document.

Winch

Winch Assembly	1-2
Motor Adapter	1-4
Clutch Shaft Assembly	1-5
External Planetary Reducer Kit	1-6
Internal Planetary Reducer Kit	1-7

Winch Assembly

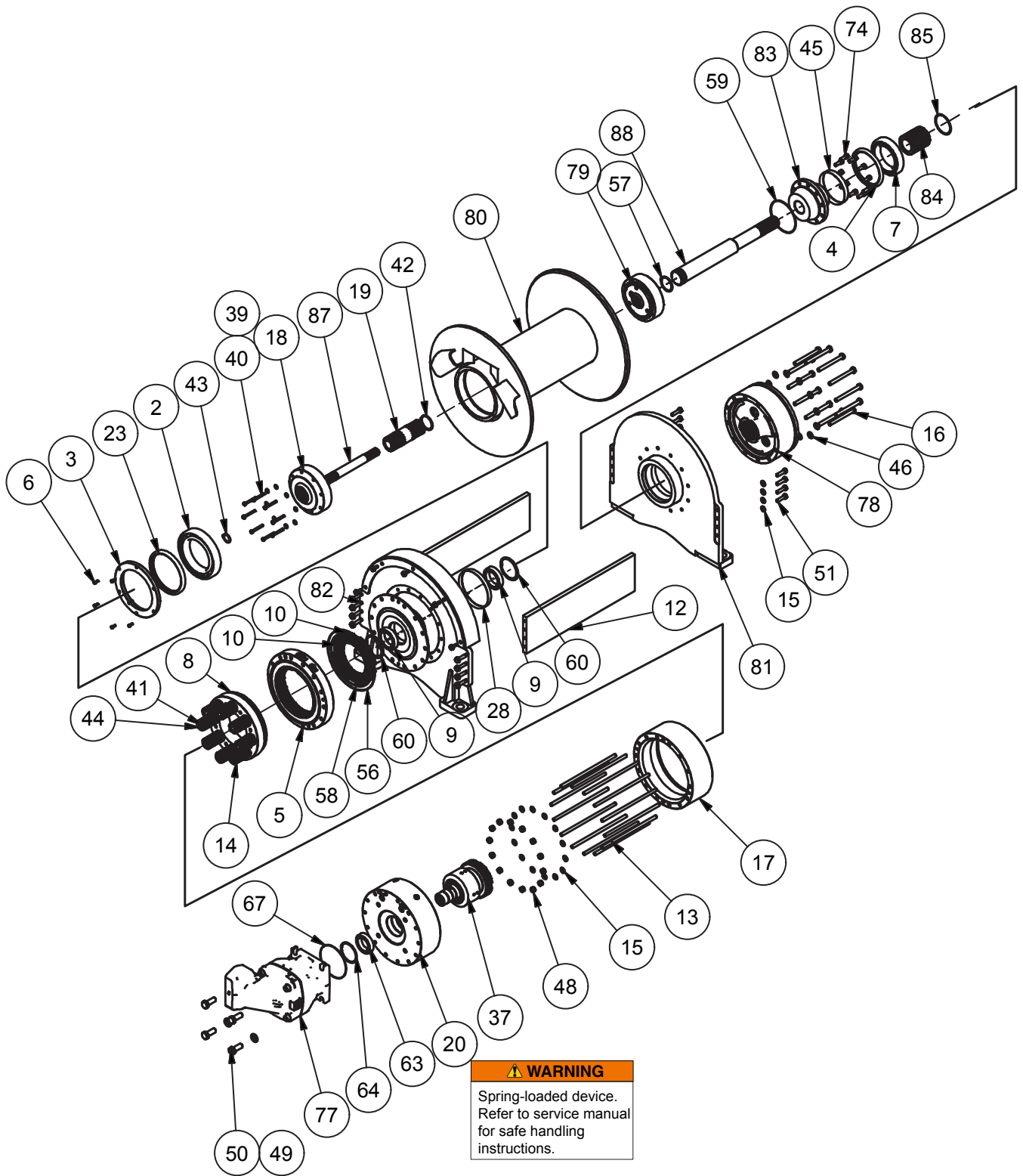

Winch Assembly

Item	Part No.	Description	Qty	Item	Part No.	Description	Qty
	2316330	Hydraulic Yarder Winch					
2	44330W	. Bearing, Ball	1	50	293706W	. Capscrew	4
3	2316187	. Seal Retainer	1	51	248986	. Capscrew	16
4	*2 1314783W	. Oil Seal	1	52	296420W	. Hard Washer	5
5	2316190	. Brake Cage	1	53	293628W	. Capscrew	5
6	R13811617	. Capscrew	6	54	235387	. Fitting	2
7	44322W	. Ball Bearing	1	55	229383	. Fitting	3
8	2316191	. Piston, Brake	1	56	*1 226256	. O-Ring	1
9	44313W	. Ball Bearing	2	57	*2 73688W	. Snap Ring	1
10	*1 328715W	. Disc - Friction	6	58	*1 18907W	. O-Ring	1
11	*1 261542W	. Plate	5	59	*1 15895W	. O-Ring	1
12	2316207	. Plate, Cross	2	60	*1 58925W	. Snap Ring	2
13	2316208	. Stud	14	62	224964	. Fitting	1
14	*1 R231333	. Spring	8	63	44311W	. Ball Bearing	1
15	296422W	. Hard Washer	30	64	*2 67551W	. Snap Ring	1
16	Y19C-M14140	. Capscrew	12	67	*2 237349	. O-Ring	1
17	2316212	. Spacer, Brake Housing	1	74	296041W	. Capscrew	10
18	2316222	. Hub, Planetary	1	77	*c 2316609	. Motor-Hydraulic	1
19	2316223	. Shaft, Brake	1	78	*d 2316610	. Planetary Reducer Kit	1
20	*a 2316327	. Motor Adapter Assembly	1	79	*e 2316286	. Planetary Reducer Kit	1
22	2316233	. Drum Guard	1	80	2316184	. Drum	1
23	*2 2316251	. Seal, Oil	1	81	2316204	. Frame	1
24	2316558	. Carrier - Bearing	1	82	2316206	. Frame	1
28	2316559	. Sleeve - Wear	1	83	2316535	. Hub, Drum	1
30	2316567	. Plug - Motor	1	84	2316536	. Shaft - Hub, Drum	1
37	*b 2316329	. Clutch Shaft Assembly	1	85	*2 2316541	. Snap Ring	1
39	R13802914	. Hard Washer	8	87	2316221	. Shaft, Input	1
40	R13811020	. Capscrew	8	88	2316224	. Shaft, Input	1
41	238585	. Spring	8	91	NS 2315005	. Nameplate	1
42	*2 12940W	. Snap Ring	1	92	NS 16602W	. Screw	4
43	*2 304526W	. Ring, Snap	1				
44	19959W	. Pin	16				
45	1314777W	. Sleeve, Seal	1		*a	See Separate Coverage on Page 1-4	
46	296424W	. Hard Washer	12		*b	See Separate Coverage on Page 1-5	
48	292656W	. Nut	14		*c	See Separate Coverage on Page 1-6	
49	296430W	. Hard Washer	4		*d	See Separate Coverage on Page 1-7	
					*e	See Separate Coverage on Page 1-8	
					NS	Not Shown	
					*1	Included in 2316618 Brake Assembly Kit	
					*2	Included in 2316621 Snap Ring/O-Ring Kit	

Motor Adapter

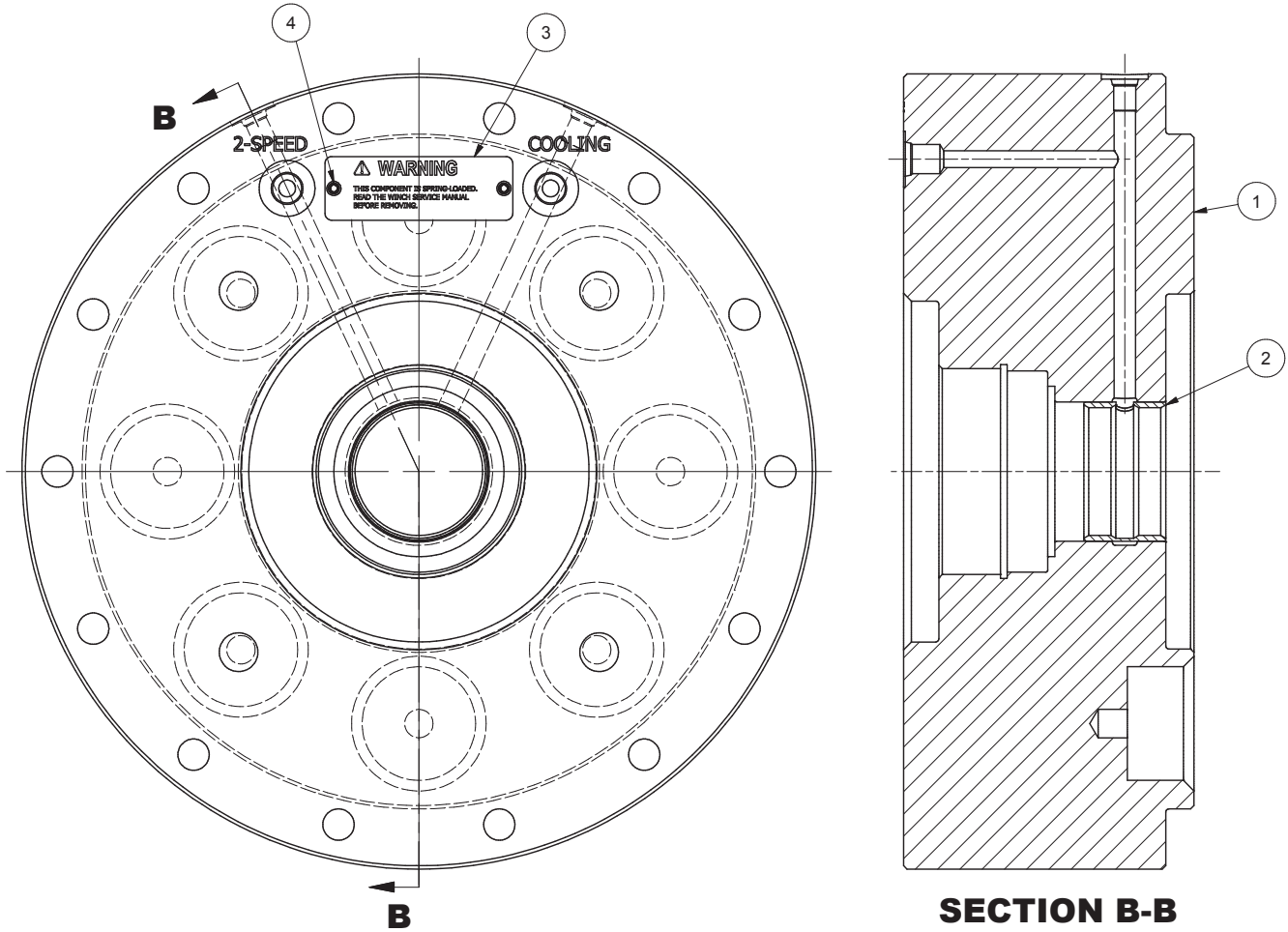

Item	Part No.	Description	Qty	Item	Part No.	Description	Qty
	2316327	Assembly, Adapter - Motor					
1	2316227	. Plate, Adapter - Motor	1				
2	2305997W	. Sleeve	1				
3	2316595	. Tag - Warning	1				
4	16602W	. Screw	2				

Clutch Shaft Assembly

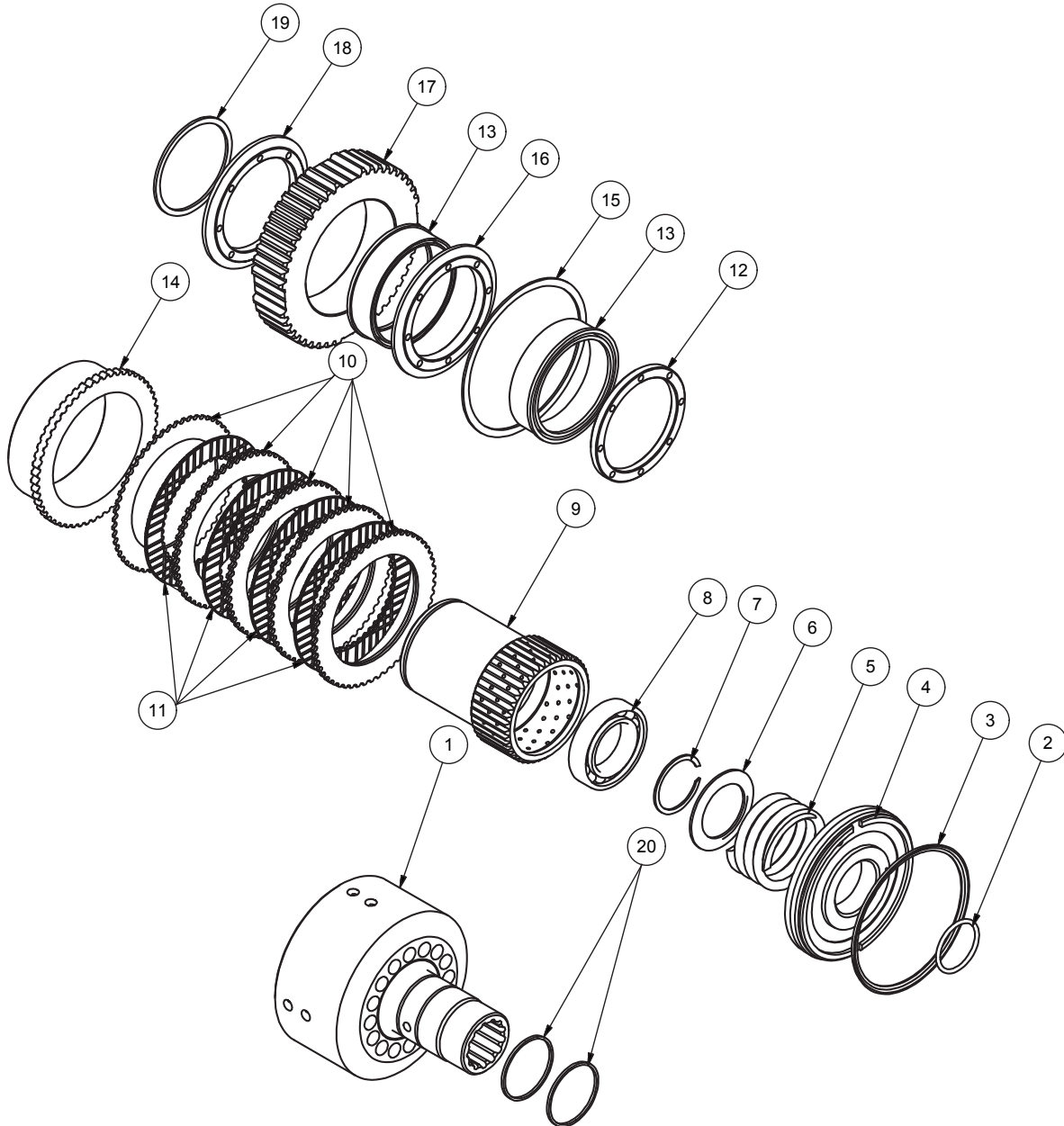

Item	Part No.	Description	Qty	Item	Part No.	Description	Qty	
	2316329	Assembly - Clutch Shaft		10	*a*b	2304874W	. Plate, Separator	9
1	2316213	. Assembly, Clutch Shaft Hsg	1	11	*a*b	2304873W	. Disc, Friction	4
2	*b	140597W	1	12		2316308	. Bushing	1
3	*b	334402W	1	13		R232351	. Sprag	2
4		1314446W	1	14		2316215	. Plate, Pressure	1
5	*a*b	1314447W	1	15	*b	334475W	. Ring - Snap	1
6		1314549W	1	16		2316287	. Bushing	1
7	*b	334480W	1	17		2316226	. Hub, Brake	1
8		44309W	1	18		2316307	. Bushing	1
9		2316214	1	19	*b	281869W	. Snap Ring	1
				20	*b	2300643W	. Seal Ring	2

*a Included in 2316619 Clutch Service Kit
 *b Included in 2316620 Clutch Shaft Kit

External Planetary Reducer Kit

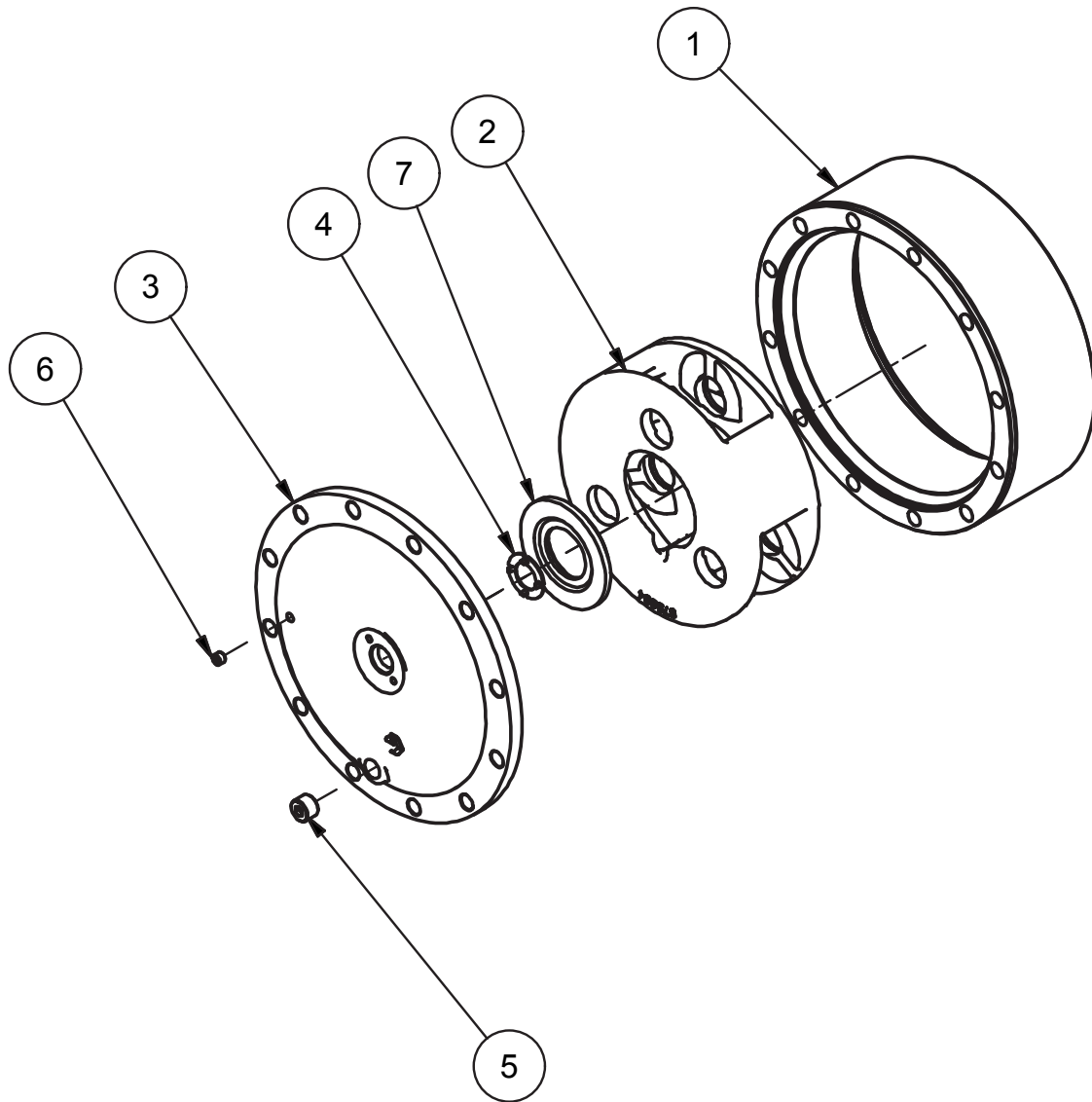

Item	Part No.	Description	Qty	Item	Part No.	Description	Qty
	2316610	Kit - Reducer, Planetary w/Spacer					
1	2316573	. Gear - Ring					
2	2316574	. Assembly - Carrier, Planetary					
3	2316575	. Cover					
4	2316576	. Washer - Thrust					
5	2316577	. Fitting					
6	15483W	. Fitting					
7	2316566	. Spacer					

Internal Planetary Reducer Kit

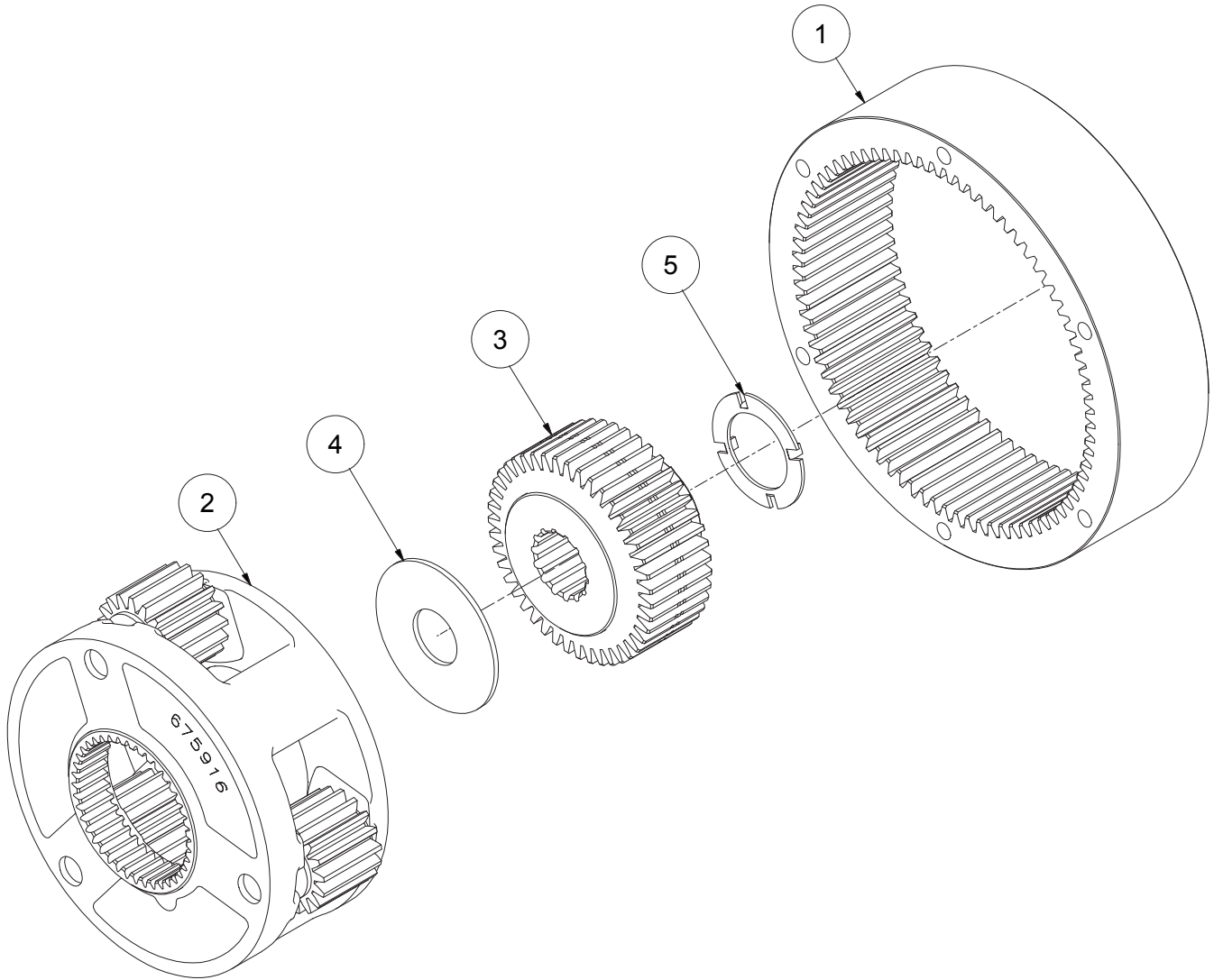

Item	Part No.	Description	Qty	Item	Part No.	Description	Qty
	2316286	Kit - Reducer, Planetary		4	2316581	. Washer - Thrust	
1	2316578	. Gear - Ring		5	2316582	. Washer - Thrust	
2	2316579	. Assembly - Carrier, Planetary					
3	2316580	. Gear - Sun					

THIS PAGE LEFT INTENTIONALLY BLANK

Suggested Spares Guide

Recommended Service Kits	2-2
• Brake Assembly Kit, P/N 2316618.....	2-3
• Clutch Service Kit, P/N 2316619	2-3
• Clutch Shaft Kit, P/N 2316620	2-3
• Snap Ring/O-Ring Kit, P/N 2316621	2-3
• Tool Kits	2-4
• Diagnostic Tools	2-4



AH250A Winch

Recommended Service Kits

The following pages list the service kits that are available for your Allied AH250A Winch. Each kit includes all parts listed in the table.

Page 2 contains a Brake Assembly Kit, a Clutch Shaft Kit, and a Snap Ring/O-Ring kit. Order the kits relevant for your winch in preparation for the 5,000 hour scheduled maintenance.

Page 3 contains a list of Tool Kits and a list of Diagnostic Tools, which will help you install and maintain your winch(es).

Note: Allied Winch Parts Manuals are available for no charge and can be downloaded at <http://www.alliedsystems.com/pubs/pubs.htm>.



Suggested Spares Guide

Brake Assembly Kit, P/N: 2316618

Applies to:		AH250A winch	See Section 1	
Service Interval:		Every 5,000 hours	in Parts Manual	
Allied P/N	Description	Quantity in Kit	Order Quantity	
2316618	Kit, Brake Assembly			
328715W	. Disc, Friction	6		
261542W	. Plate, Separator	5		
R231333	. Spring	8		
226256	. O-Ring	1		
18907W	. O-Ring	1		
15895W	. O-Ring	1		
58925W	. Snap Ring	2		

Clutch Shaft Kit, P/N: 2316620

Applies to:		AH250A winch	See Section 1	
Service Interval:		Every 5,000 hours	in Parts Manual	
Allied P/N	Description	Quantity in Kit	Order Quantity	
2316620	Kit, Clutch Shaft			
2316619	. Service Kit, AH250A Clutch	1		
2304873W	. . Disc, Friction	4		
2304874W	. . Plate, Separator	9		
1314447W	. . Spring	1		
140597W	. O-Ring	1		
334402W	. Seal	1		
334480W	. Snap Ring	1		
334475W	. Snap Ring	1		
281869W	. Snap Ring	1		
2300643W	. Seal, Ring	1		

Snap Ring & O-Ring Kit, P/N: 2316621

Applies to:		AH250A winch	See Section 1	
Service Interval:		Every 5,000 hours	in Parts Manual	
Allied P/N	Description	Quantity in Kit	Order Quantity	
2316621	Kit, Snap Ring & O-Ring			
1314783W	. Seal, Oil	1		
2316251	. Seal, Oil	1		
237349	. O-Ring	1		
12940W	. Snap Ring	1		
304526W	. Snap Ring	1		
73688W	. Snap Ring	1		
67551W	. Snap Ring	1		
2316541	. Snap Ring	1		



Suggested Spares Guide

Tool Kits

Order these Tool Kits as required for installation, maintenance and service of your winch(es).

Allied P/N	Description	Order Quantity
588466	Socket Set, 3/8DR 3/8" to 7/8" STD/Deep, 22 PC	
588467	Socket Set, 1/2DR 3/8" to 1-1/4" STD/Deep, 30 PC	
588468	Socket Set, 3/4DR 7/8" to 2-3/8" STD, 29 PC	
588469	Wrench Set, 5/16" to 2-1/2", 31 PC	
588527	Hex Key Sets, .025" to 5/8", 18 PC	
588530	Socket Sets, 3/8DR 6mm-19mm 12 Point	
588529	Socket Sets, 1/2DR 10mm-26mm 12 Point	
588528	Wrench Sets, 7mm-24mm, 18 PC	
588526	Hex Key Sets, .07mm-17mm, 15 PC	

Diagnostic Tools

Order these Tools as required for maintenance and service of your winch(es).

Allied P/N	Description	Order Quantity
906601	0 to 8700 PSI Digital Pressure Gauge W/Female QD Connector	
69782	72" Hose Assembly W/QD Connectors Both Ends	
70381	144" Hose Assembly W/QD Connectors Both Ends	
X-204240	Brake Spring Compression Tool	

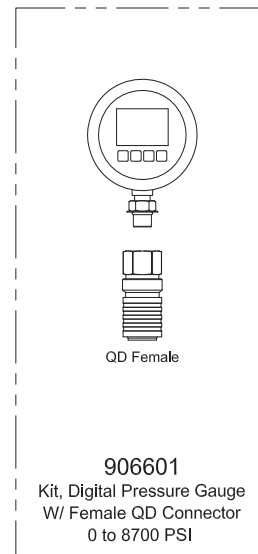
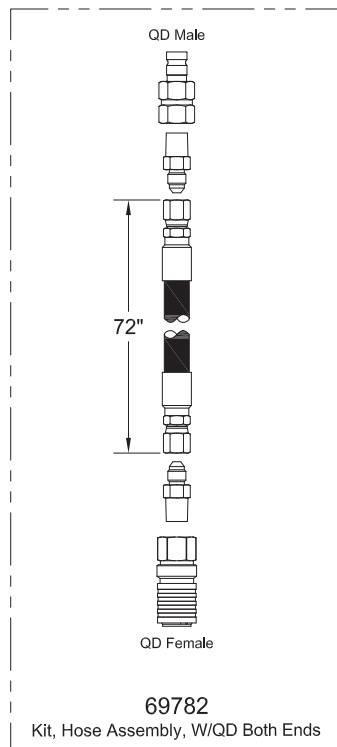
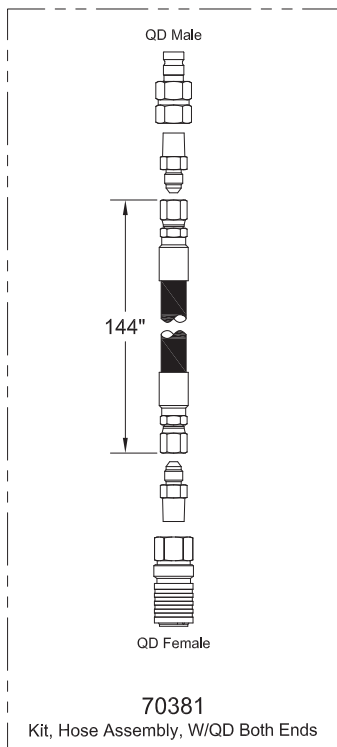



To find a dealer in your area,
Call: (503) 625-2560,
Fax: (503) 625-7269 , or
Email: marketing@alliedsystems.com, or
Visit our website: <http://www.alliedsystems.com>

Allied Systems
COMPANY

599039W 04/17/2017 Printed in U.S.A.