

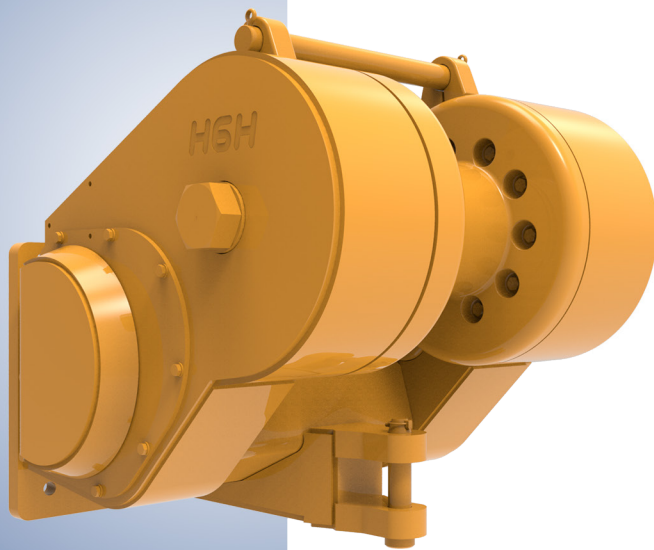

Parts Manual



Allied H6H

Hydraulic Winch for Shantui Dozers

Please check the Allied Systems website
regularly for updates to this manual.
www.alliedsystems.com

CUSTOMER EDITION

Safety Precautions

**Read, understand and observe the Safety Summary
on pages 2 through 4
to prevent injury to personnel and damage to equipment.**

Winch serial number _____

Date put into service _____

**NOTE: This publication may be translated to different languages for sole purpose
of easy reference in non-English speaking locations.
Should there be differences in interpretations to the text,
please refer to the English language edition published by Allied Systems Company
as the controlling document.**

Index

H6H Winch Parts for Shantui

Safety Summary	2
Unit Identification	5
Oil Specifications	7
Ordering Parts	8
Nameplate & Decals	9
Section 1 Frame/Covers/Mounting Parts	11
Section 2 Gear/Shaft Train	15
Section 3 Hydraulics/Electrical/Controls	29
Section 4 Optional Equipment	34
Section 5 Recommended Service Intervals & Kits	41
Section 6 Recommended Service Parts	49
Section 7 Numerical Index	55

Safety Summary

General Safety Notices

The following pages contain general safety warnings which supplement specific warnings and cautions appearing elsewhere in this manual. All electrical and hydraulic equipment is dangerous. You must thoroughly review and understand the Safety Summary before attempting to operate, troubleshoot or service this winch.

The following symbols and terms are used to emphasize safety precautions and notices in this manual:

DANGER

The “DANGER” symbol indicates a hazardous situation which, if not avoided, will result in serious injury or death. Carefully read the message that follows to prevent serious injury or death.

WARNING

The “WARNING” symbol appears wherever incorrect operating procedures or practices could cause serious injury or death. Carefully read the message that follows to prevent serious injury or death.

CAUTION

The “CAUTION” symbol appears where a hazardous situation which, if not avoided, could result in minor to moderate injury and equipment damage.

NOTICE

This signal word alerts to a situation that is not related to personal injury but may cause equipment damage.

NOTE: ...

The term “NOTE” highlights operating procedures or practices that may improve equipment reliability and/or personnel performance.

Safety Regulations

Each country has its own safety legislation. It is in the operator’s own interest to be conversant with these regulations and to comply with them in full. This also applies to local bylaws and regulations in force on a particular worksite.

Should the recommendations in this manual deviate from those in the user’ country, the national regulations should be followed.

Operation, Inspection, and Maintenance Warnings

WARNING

Multiple hazards.

Ignoring safety warnings may cause equipment damage, personal injury or death.

All possible safety hazards cannot be foreseen and included in this manual. The operator must always be alert to possible hazards that could endanger personnel or damage the equipment.

Training

- Do not operate the winch unless your are authorized and trained to do so.
- Read, understand, and follow the operating, inspection, and maintenance instructions in this manual.
- Keep yourself informed of any applicable codes, regulations and standards for the job.

Personnel Safety

- Stay in the operator’s seat when operating the winch.
- Do not stand on the vehicle when operating the winch.

- Avoid winch operation near people or other machines.
- Never stand nor permit others to stand in the bight (loop) of a wire rope.
- Do not stand nor permit others to be near the winch or wire rope when there is tension on the wire rope.



- Make sure ground personnel are in plain view of the operator, and at a distance of at least 1½ times the working length of the wire rope.
- Observe jobsite rules.
- Do not use the control levers for hand holds when entering or leaving the vehicle.
- Be in complete control at all times.
- Do not use the control levers as hangers for clothes, water bags, grease guns, lunch pails, etc.
- Do not leave the vehicle when the winch wire rope is under tension.
- Do not permit riders on the vehicle or load.
- Operation Warnings
- Do not operate the winch unless the vehicle is equipped with a screen to protect the operator if the wire rope breaks.
- Be aware of the ground conditions, and make sure the ground and dozer are stable enough to pull the intended load.
- Do not attempt to pull loads in excess of the rated capacity of the winch.
- Make sure that any hand signals used by ground personnel are clearly defined and understood by everyone involved.

- Do not attempt to “jerk” or “shock” a load free. Doing so can cause loads in excess of the rated capacity of the wire rope, winch, or mounting hardware.
- Your winch may have temperature shut-off system for protection of dozer and winch. Manual override of high temperature shut-off will cause damage to dozer and winch.
- This winch is neither intended, designed, nor rated for any application involved in the lifting or moving of personnel.
- Do not use the winch as an anchor for a double or two-part line.
- Do not pull the hook through the throat or over the drum, which will cause damage.
- When the winch is not in use, make sure the control lever is in **BRAKE-ON** position and the winch brake is applied.
- Do not use winch as a hoist. Dozer and skidder mounted winches are designed for towing.

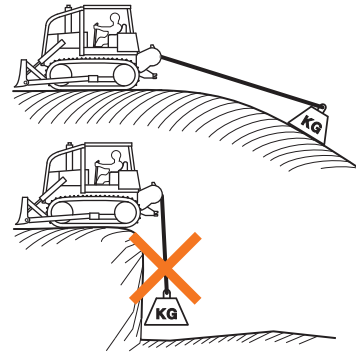

Wire Rope Safety

- Always inspect wire rope, tail chain and other rigging components for wear, damage, broken strands or abuse before use.
- Never use wire rope, tail chain or other rigging that is worn-out, damaged or abused.
- Never overload wire rope, tail chain or rigging.
- Wire rope and tail chain will fail if worn-out, overloaded, misused, damaged, improperly maintained or abused.

WARNING

Wire rope or tail chain failure may cause serious injury or death.

Inspect rigging before use and obey all safety warnings.

- Do not terminate wire rope to tail chain by the use of a knot.
- Do not handle wire rope if the hook end is not free. A load could break away, suddenly tensioning the wire rope, resulting in serious injury or death.
- Stay clear of wire rope entry areas (fairlead or arch rollers, winch drum etc).
- Maintain **a minimum of three (3) complete wraps of wire rope** on the drum for normal operation. It may help to paint the last five wraps of wire rope a contrasting color, to serve as a visual indicator.
- Do not handle wire rope with bare hands. Wear leather gloves at all times.
- Align the dozer with the load to prevent side loading the winch, and to maintain even spooling of the wire rope.
- If applying tension to the wire rope manually during spooling:
 - » ensure that the operator is winching in slowly,
 - » keep your hands and clothing well clear of any rollers or the winch drum,
 - » do not maintain tension by letting the wire rope to slip through your hands,
 - » use a hand-over-hand technique to maintain tension.

Maintenance Warnings

- Do not permit other people near the control area when you inspect or repair a machine.
- Never inspect, repair, or perform maintenance on a machine that is in motion.
- Inspect the winch before each use:
 - » Make sure that the controls and instruments operate correctly.
 - » Report the need for repairs immediately.
 - » Do not work with a damaged or worn wire rope.
 - » Do not use a winch that needs repairs.

» If the wire rope and ferrule must be removed from the drum, make sure the end of the wire rope and ferrule are controlled when the ferrule is released. The end of the wire rope can suddenly move from the drum like a compressed spring when the ferrule is released, and cause an injury.

- Replace any parts only with genuine Allied Winch parts.
- Use only the lubricants listed in the Recommended Oil List, page 8.
- The hydraulic system must be kept clean and free of contamination at all times.
- Do not weld on any part of the winch. Contact Allied Systems if weld repairs are needed.

Hydraulic Hazards

- Wear personal protective equipment, such as gloves and safety glasses, whenever servicing or checking a hydraulic system.
- Assume that all hydraulic hoses and components are pressurized. Relieve all hydraulic pressure before disconnecting any hydraulic line.
- Never try to stop or check for a hydraulic leak with any part of your body; use a piece of cardboard to check for hydraulic leaks.
- Small hydraulic hose leaks are extremely dangerous, and can inject hydraulic oil under the skin, even through gloves.

DANGER

Injection hazard.

Infection and gangrene will result when hydraulic oil penetrates the skin. See a doctor immediately to prevent loss of limb or death.

Use a piece of cardboard to check for hydraulic leaks.



Unit Identification

Allied Winch Serial Number Nameplate Data For Dozer Mountings

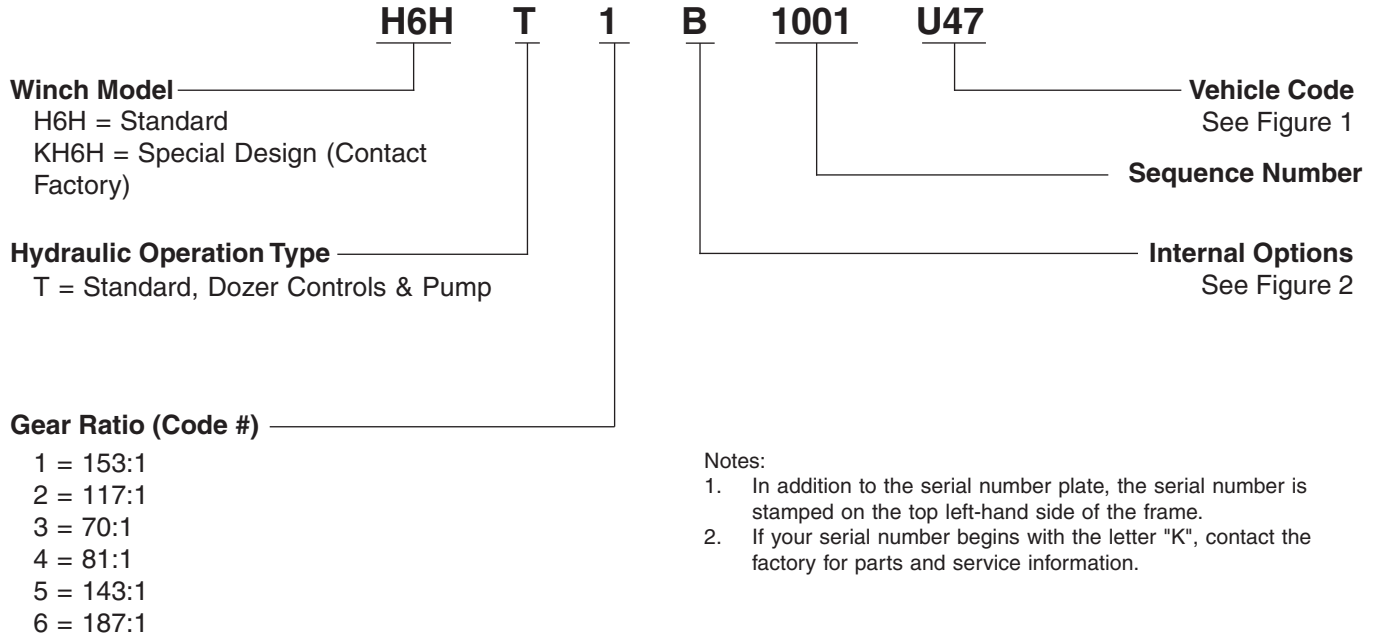

Notes:

1. In addition to the serial number plate, the serial number is stamped on the top left-hand side of the frame.
2. If your serial number begins with the letter "K", contact the factory for parts and service information.

C O D E	U Shantui
47	DH17 ©

Figure 1 - Dozer or Skidder Identification Codes and Available Gear Ratios

Circled numbers in Figure 1 indicate possible gear ratios.

	FREESPOOL	BRAKE-OFF	OVERWIND	2-SPEED CONTROL
B	X	X	X	
D	X	X	X	X
E	X		X	
U	X	X		
BN		X	X	
DN		X	X	X
EN			X	
DE	X		X	X
DU	X	X		X

Figure 2 - Internal Winch Options

When the part number and the next higher assembly is not known:

1. Determine the function and application of the part required. Turn to the illustrated index page immediately behind the front cover, and select the most appropriate area.
2. Use the table of contents at the beginning of each chapter to determine the assembly which would normally contain the part required. Proceed then to locate the part on the assembly breakdown page.

When the part number is not known and the next higher assembly is known:

1. Determine the assembly the required part is used on. Turn to the master index (which immediately follows the illustrated index).
2. Locate the assembly on which the required part is used, and turn to the page indicated for that assembly. Proceed to locate the part on the assembly breakdown page.

When the part number is known:

Use the numerical index to find the part number. Turn to the page listed and locate the part as indicated by the reference number.

General:

The assembly breakdowns include part numbers, descriptions, quantities required, keys and footnotes to help in selecting the correct parts.

Keys are used to show effective serial numbers for two or more similar assemblies, LH and RH assembly parts, etc. Select the appropriate key, "A," "B," "C," or "D" and the corresponding quantity column to find the required parts.

Indent dots are used to indicate assemblies and sub-parts of assemblies. No dot indicates the major assembly. Part descriptions which are indented with dots are sub-parts of the major assembly shown above.

Quantities shown are for one assembly. Note that when two assemblies are shown, but the quantity of the sub-parts is indicated as three, this means three per assembly - for a total of six. AR means As Required, and NSS indicates Not Sold Separately.

Serial numbers are shown to allow for the most current parts information to be incorporated into the parts manual. See page 6 for serial number information.

Abbreviations

Abbreviations are used both on the winch and in this manual. For example, a manifold may have a port stamped "FS". That port is related to the "freespool" circuit. This abbreviation is also used on pages in this manual that reference this port, or the ports connected to this port. Figure 3 lists the most common abbreviations used in this manual.

Abbreviation	Full Name
P	Pressure
T	Tank
BO	Brake Off
FA	Filter Outlet
FE	Filter Inlet
FS	Freespool
HS	High Speed
LS	Load Sense
PD	Pilot Drain
PP	Pilot Pressure
PS	Pilot Supply
RI	Reel In
RO	Reel Out
TP	Test Port
TS	Temperature Switch

Figure 3 - Abbreviations

Oil Specifications

Oil Selection

To get the most suitable temperature-viscosity characteristics, choose one of the oils listed below.

Manufacturer	Winch Case (Gear Train)
Exxon-Mobil (standard)	Mobil Trans HD Series
Chevron (optional)	Drive Train Fluids HD
Caterpillar (optional)	TO-4

Figure 4 - Recommended Oil List

Factory fill is Exxon-Mobil Trans HD 30.

Note: This winch uses hydraulic fluid from the dozer. See Figure 4 for recommended gear train fluids. Contact the factory if alternate oils are required.

Use of a non-recommended oil may void the warranty.

Oil Capacity

Oil capacity for the H6H winch is 4 gallons (15 liters).

Viscosity Grade		Oil Operating Temperature Range		Typical Ambient Temperature Range	
ISO	SAE	°F	°C	°F	°C
VG 22	10W	-5 to 140	-20 to 60	-5 to 40	-20 to 4
VG 32	15W	10 to 160	-12 to 71	10 to 55	-20 to 13
VG 46	20	20 to 180	-7 to 82	20 to 70	-7 to 21
VG 68	20	30 to 200	-1 to 93	30 to 90	-1 to 32
VG 100	30	40 to 220	4 to 104	40 to 110	4 to 43

Figure 5 - Viscosity Chart

Ordering Parts

When ordering replacement parts, give the unit serial number, part number, name of part and quantity required.

For any further information on parts, service or ordering, consult your local winch dealer, or contact Allied Systems Company:

Allied Systems Company
21433 SW Oregon Street
Sherwood, OR 97140 U.S.A.

Phone: 503-625-2560

Fax: 503-625-5132

E-mail: parts@alliedsystems.com

Also see our website, www.alliedsystems.com, where the most current copy of this manual is always available.

NOTE: This publication may be translated to different languages for sole purpose of easy reference in non-English speaking locations. Should there be differences in interpretations to the text, please refer to the English language edition published by Allied Systems Company as the controlling document.

Nameplate & Decals



ALLIED SYSTEMS COMPANY
21433 SW OREGON STREET
SHERWOOD, OREGON 97140 USA
WWW.ALLIEDSYSTEMS.COM

MODEL: H6H 20##
SERIAL NO.: H6H%\$?#####@@@

MAXIMUM LINE PULL*
BARE DRUM: 88,800 LBS
MAXIMUM WIRE
ROPE DIAMETER: 1 INCH DIA

*LIMITED BY WIRE BREAKING STRENGTH. MAY BE LOWER DUE TO AVAILABLE POWER FROM WINCH CARRIER. CONTINUOUS LINE PULLS SHOULD BE LESS THAN WINCH CARRIER GVW.

MADE IN USA 2315005 REV A

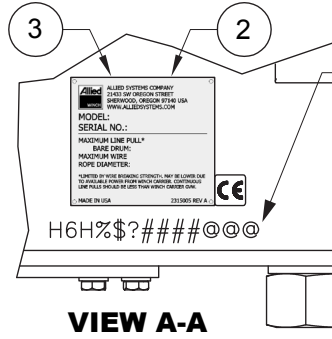

STAMP NAMEPLATE AND FRAME AS SHOWN
% = H (HI-PERFORMANCE) OR T (STANDARD)
\$ = GEAR RATIO CODE
? = INTERNAL OPTIONS
= SEQUENCE NUMBER
@@@ = VEHICLE CODE
SEE DRAWING 231271



40

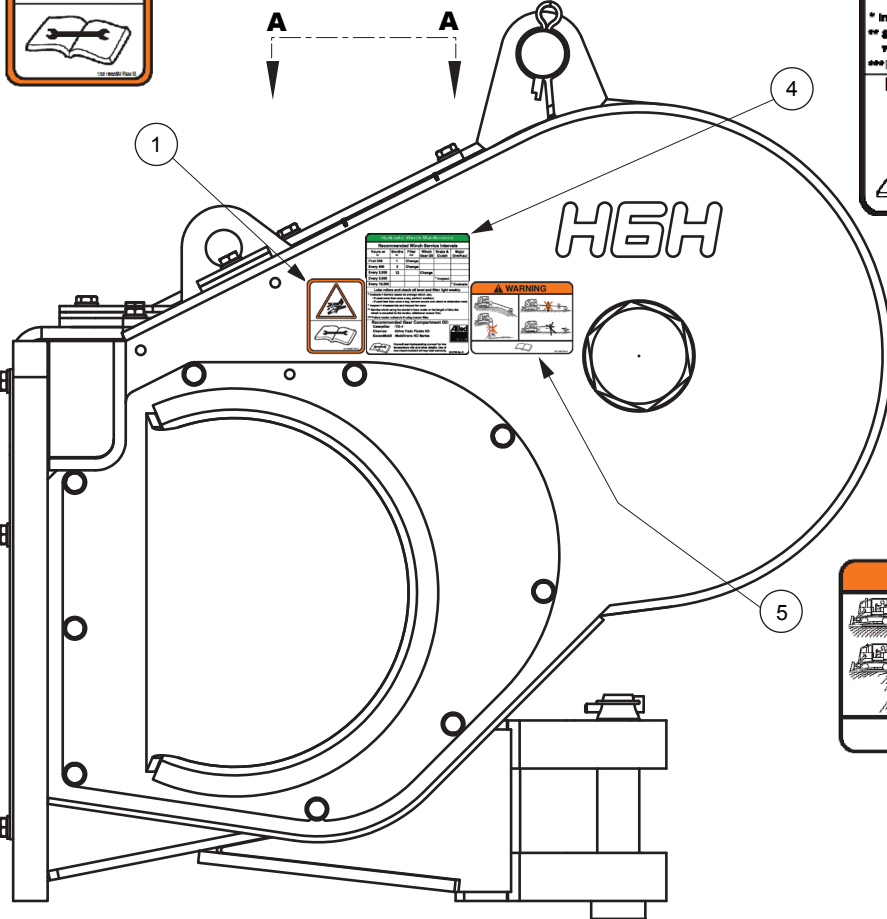

Hydraulic Winch Maintenance

Recommended Winch Service Intervals					
Hours or **	Months **	Filter ***	Winch Gear Oil	Brake & Clutch	Major Overhaul
First 250	1	Change			
Every 500	3	Change			
Every 2,000	12		Change		
Every 5,000				* Inspect	
Every 10,000					* Evaluate

Lube rollers and check oil level and filter light weekly.

* Evaluate = Service based on average winch use;
- If used more than once a day, perform overhaul.
- If used less than once a day, remove covers and check to determine need.
* Inspect = disassemble and inspect for wear.
** Service winch using the tractor's hour meter or the length of time the winch is mounted to the tractor, whichever occurs first.
*** Follow tractor schedule if using tractor filter.

Recommended Gear Compartment Oil:

Caterpillar	-TO-4
Chevron	-Drive Train Fluids HD
ExxonMobil	-Mobiltrans HD Series

 Consult service/operating manual for low temperature oils and other details. Use of non-recommended oil may void warranty. 2310796 Rev D

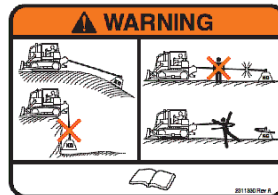

Item	Part No.	Qty	Description	Item	Part No.	Qty	Description
1	1321665W	2	Decal, Warning	4	2310796	1	Decal, Maintenance
2	2315005	1	Nameplate	5	2311330	1	Decal, Load & Wire Rope
3	16602W	4	Screw	40	-----	AR	Label - CE Mark

Intentionally Blank

Section 1
Frames and Covers

Frame/Covers

Shantui DH17 (H6HT**U47)

Page 1 of 2

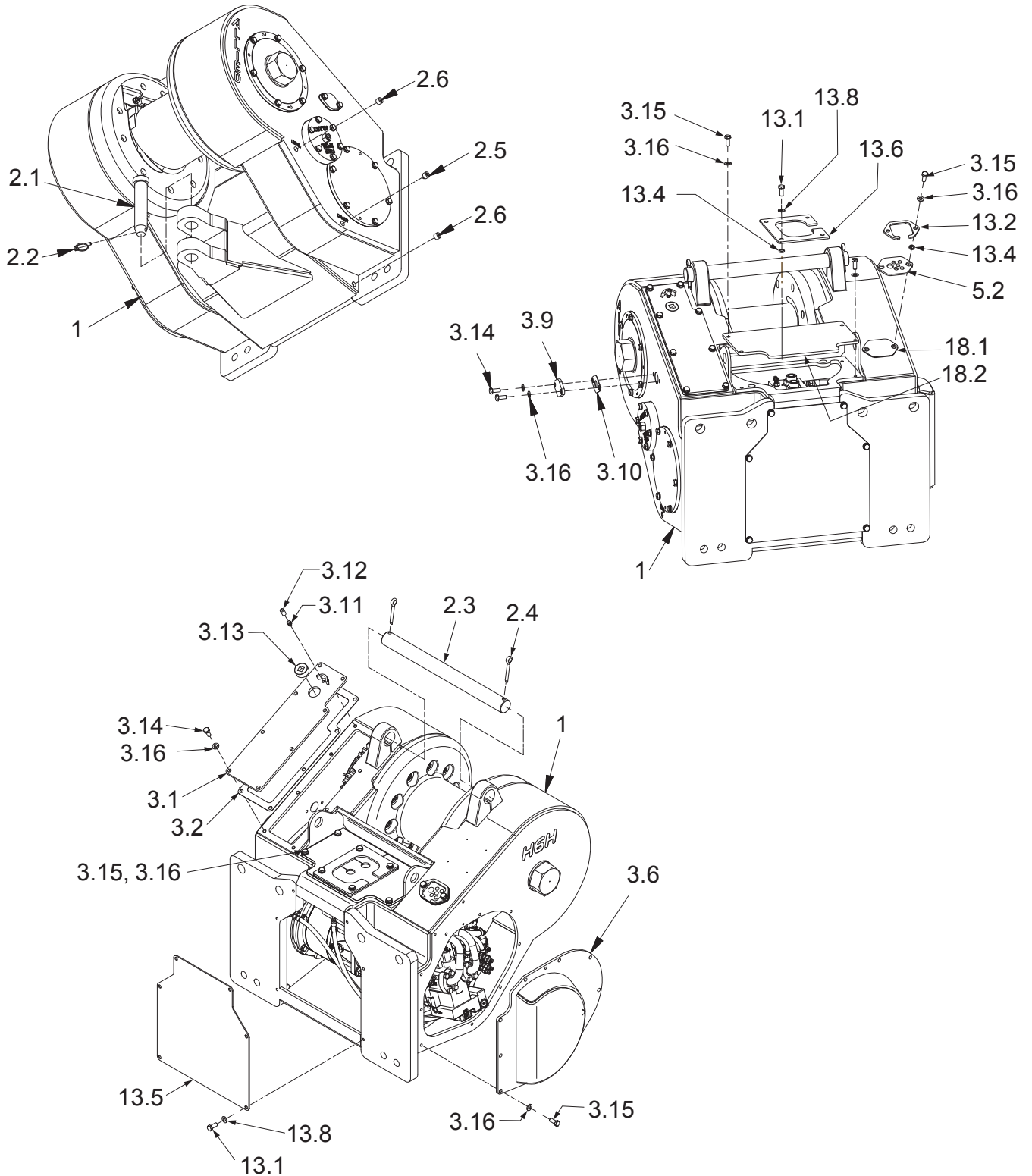

Frame/Covers

Shantui DH17 (H6HT**U47)

Page 2 of 2

Item	Part No.	Qty	Description	Item	Part No.	Qty	Description
1	-----	1	Frame, H6H	3.13	15319W	1	Fitting
2.1	95959W	1	Pin, Drawbar	3.14	2312486	10	Capscrew
2.2	2303221W	1	Pin, Retaining	3.15	293645W	15	Capscrew
2.3	2312580	1	Rod, Tie	3.16	296422W	25	Washer
2.4	15272W	2	Pin	5.2	2312208	1	Gasket, Hose Seal
2.5	15290W	1	Fitting	13.1	293645W	10	Capscrew
2.6	15315W	2	Fitting	13.2	2312117	1	Cover
3.1	2312048	1	Cover, Top RH	13.4	2312119	6	Spacer
3.2	2312045	1	Gasket, Top RH	13.5	2312046	1	Cover, Front
3.6	2316162	1	Cover, LH	13.6	2312006	1	Clamp, Top
3.9	151589W	1	Cover, Freespool	13.8	296422W	10	Washer
3.10	151646W	1	Gasket, Freespool	18.1	2312850	1	Cover, Top LH
3.11	21420W	1	Plug, Breather	18.2	2312849	1	Cover, Top
3.12	2300962W	1	Cap, Breather				

Mounting/Installation Parts

Shantui DH17 (H6HT**U47)

Note:

Mounting/installation parts are customer-supplied for this model.

Section 2
Gear Shaft/Train

Motor Shaft Group

Page 1 of 2

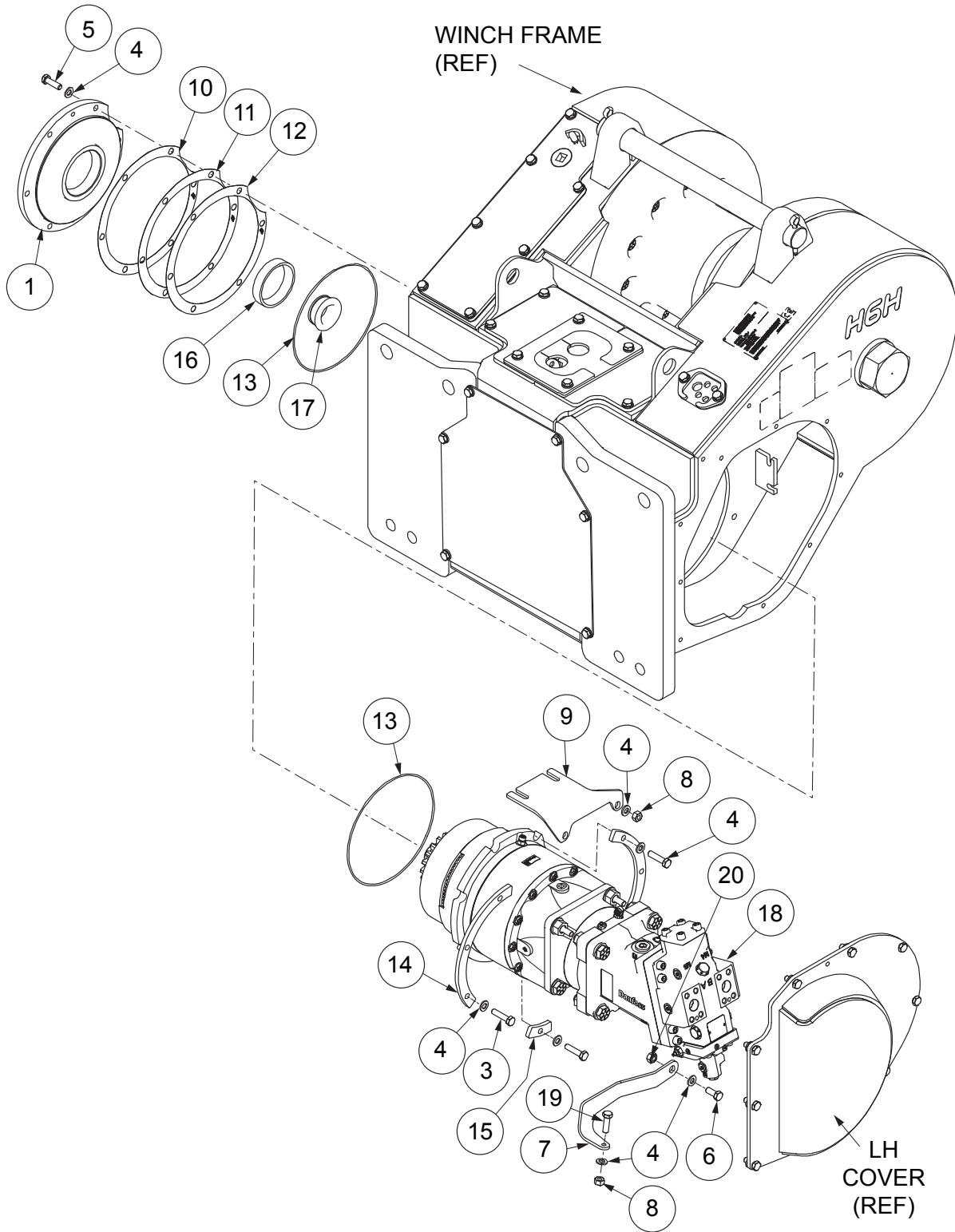

Motor Shaft Group

Page 2 of 2

Item	Part No.	Qty	Description	Item	Part No.	Qty	Description
	2311819		Motor Shaft Group				
1	2311857	1	. Cover, Bearing	14	2311917	2	. Plate, Clamp
3	2312488	7	. Capscrew	15	2311918	1	. Plate, Clamp
4	296422W	19	. Washer	16	*b 2300668W	1	. Cup, Bearing
5	2312487	6	. Capscrew	17	*b 2300669W	1	. Cone, Bearing
6	293645W	1	. Capscrew	18	- - - -	1	. Assy, Motor Shaft
7	*c 2316491	1	. Bracket, Motor Support	19	293647W	1	. Capscrew
7	*d 2312036	1	. Bracket, Motor Support	20	2305130W	1	. Nut, Bracket Support
8	292656W	3	. Nut				
9	2312018	1	. Plate, Manifold Bracket				
10	2312061	AR	. Shim .020	*a	Included in Motor, Reducer & Brake Assembly Rebuild Kit 2314659		
11	2312059	AR	. Shim .005	*b	Included in Intermediate/Drum Shaft & Brake Assembly Rebuild Kit 2314660		
12	2312060	AR	. Shim .007	*c	First Used S/N 1714		
13	*a 203564	2	. O-Ring	*d	Last Used S/N 1713		
				*e	See page 18 for details.		

Motor Shaft Assembly

Shantui

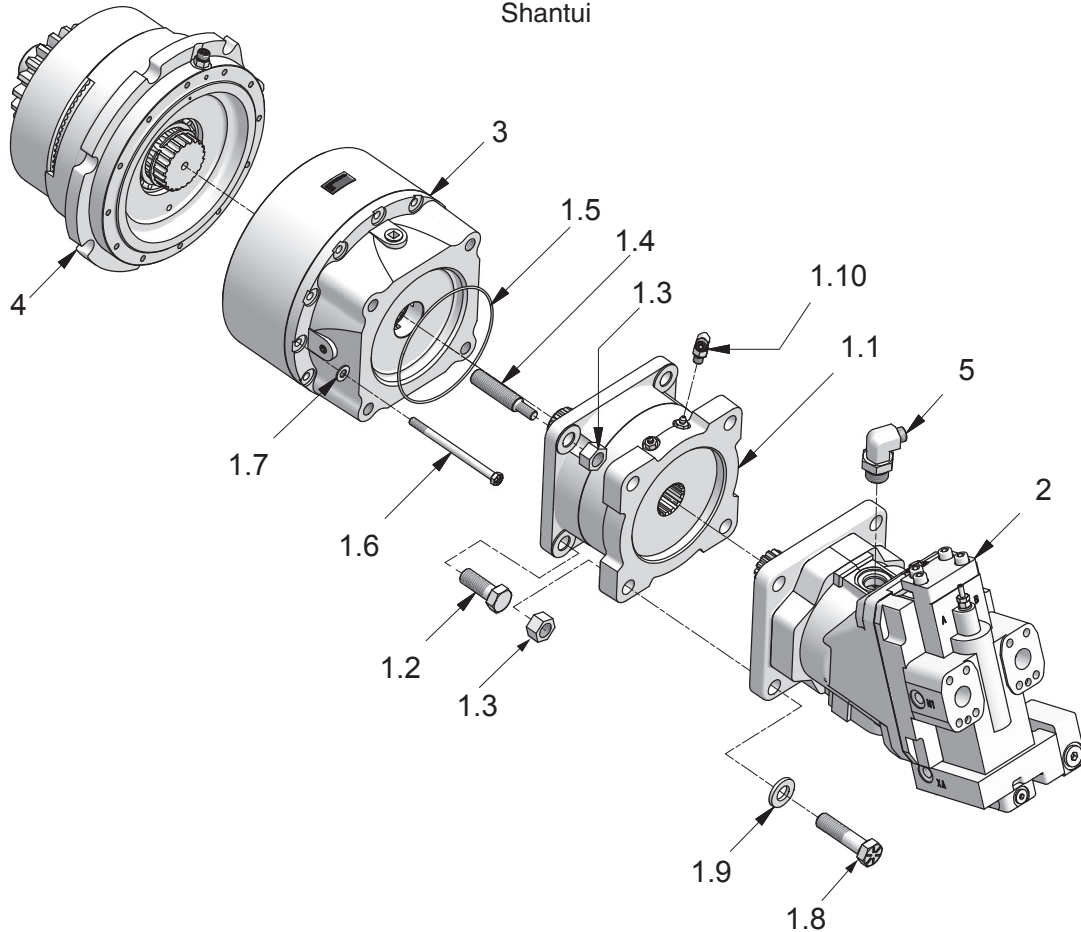

Motor Shaft Assembly

Shantui DH17 (H6HT6B**U47) Last Used S/N1713

Item	Part No.	Qty	Description	Item	Part No.	Qty	Description
	2316071		Assembly, Motor Shaft				
1.1	*a 2316071	1	. Brake, D Mount Dry Disk	1.9	221777W	4	. Washer
1.2	Y17C-1232	2	. Capscrew	1.10	R833251	1	. Fitting
1.3	221716W	6	. Nut	2	*c 2316072	1	. Motor, Hydraulic
1.4	2312041	2	. Stud	NS	2313890	1	. . O-Ring, Pilot Motor
1.5	*b 237349	1	. O-Ring	NS	2313891	1	. . Kit, Shaft Seal
1.6	R13801826	12	. Capscrew	3	2312554	1	. Reducer, Planetary
1.7	221767W	12	. Washer	4	2312928	1	. Assembly, Shaft
1.8	177192W	4	. Capscrew				

Motor Shaft Assembly

Shantui DH17 (H6HT6B**U47) First Used S/N1714

Item	Part No.	Qty	Description	Item	Part No.	Qty	Description
	2316468		Assembly, Motor Shaft				
1.1	*a 2316071	1	. Brake, D Mount Dry Disk	2	2316469	1	. Motor, Hydraulic
1.2	Y17C-1232	2	. Capscrew	NS	2313890	1	. . O-Ring, Pilot Motor
1.3	221716W	6	. Nut	NS	2313891	1	. . Kit, Shaft Seal
1.4	2312041	2	. Stud	3	2312554	1	. Reducer, Planetary
1.5	*b 237349	1	. O-Ring	4	2312928	1	. Assembly, Shaft
1.6	R13801826	12	. Capscrew				
1.7	221767W	12	. Washer	*a	See page 25 for details		
1.8	177192W	4	. Capscrew	*b	Included in Motor, Reducer & Brake Assembly Rebuild Kit 2314659		
1.9	221777W	4	. Washer	*c	See page 20 for Motor Replacement Kit		
1.10	R833251	1	. Fitting	NS	Not Shown		

Intentionally Blank

Motor Replacement Kit

Page 1 of 2

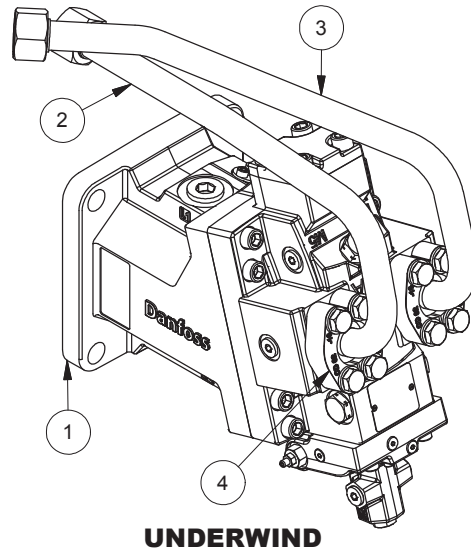
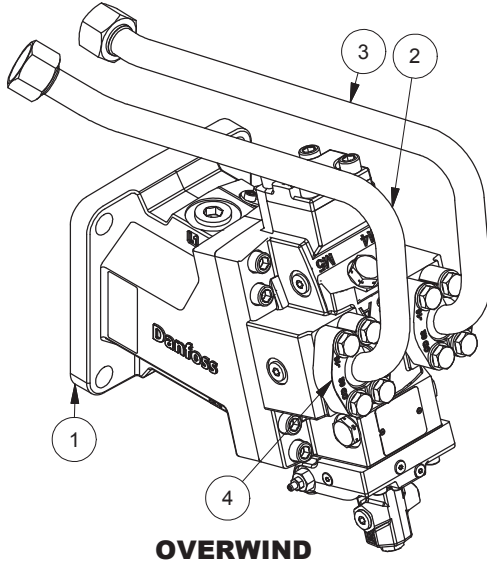

Item	Part No.	Qty	Description	Item	Part No.	Qty	Description
1	*a	-----	1	Motor - Hyd; Danfoss H1B			
2	*a	-----	2	Tube Assy - Motor A			
3	*a	-----	6	Tube Assy - Motor B			
4	592255	2	Kit, Split Flange				

*a Refer to the chart below to determine replacement parts for cancelled motors

WINCH MODEL	KIT PART NUMBER:	OVERWIND/ UNDERWIND	CANCELLED MOTOR:	ITEM 1 (CURRENT MOTOR):	ITEM 2 (TUBE A):	ITEM 3 (TUBE B):
H6HT6B**U47	2316943	O	2316072	2316469	2316108	2316109
	2316944	U	2316072	2316469	2316714	2316715

Notes:

Use this chart to determine which H1B motor replaces the cancelled 51V motor.

Be sure to note whether your motor is overwind or underwind to get the appropriate kit. Each kit contains all the components needed to convert your winch to the current motor.

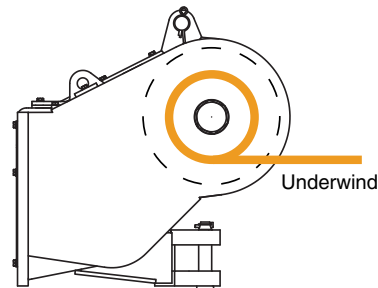
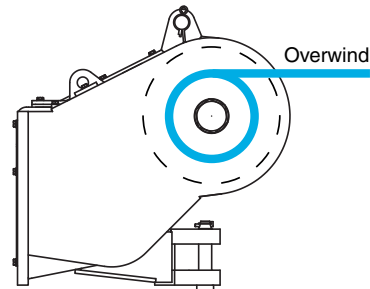

Motor Replacement Kit

Page 2 of 2

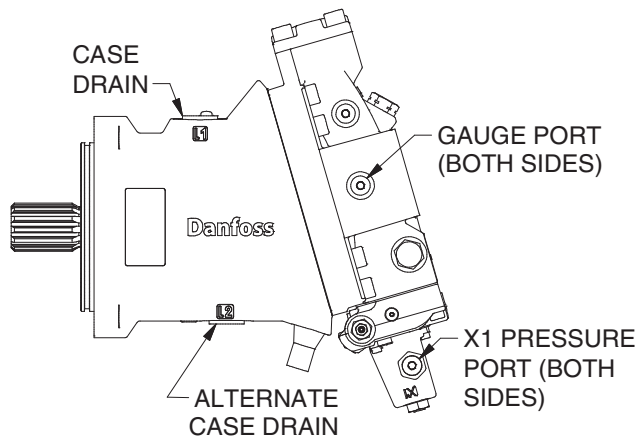

**H1B MOTOR
(NEW)**

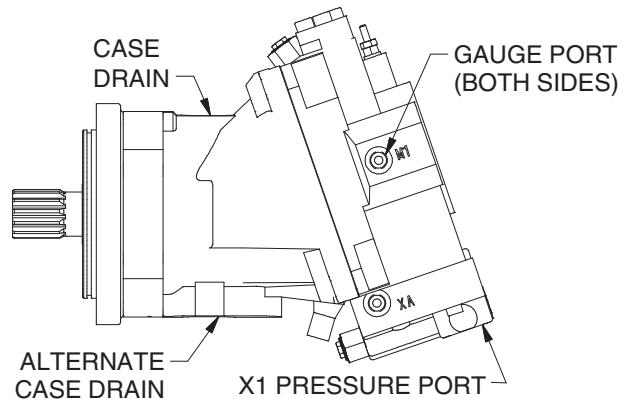

**51V MOTOR
(LEGACY)**

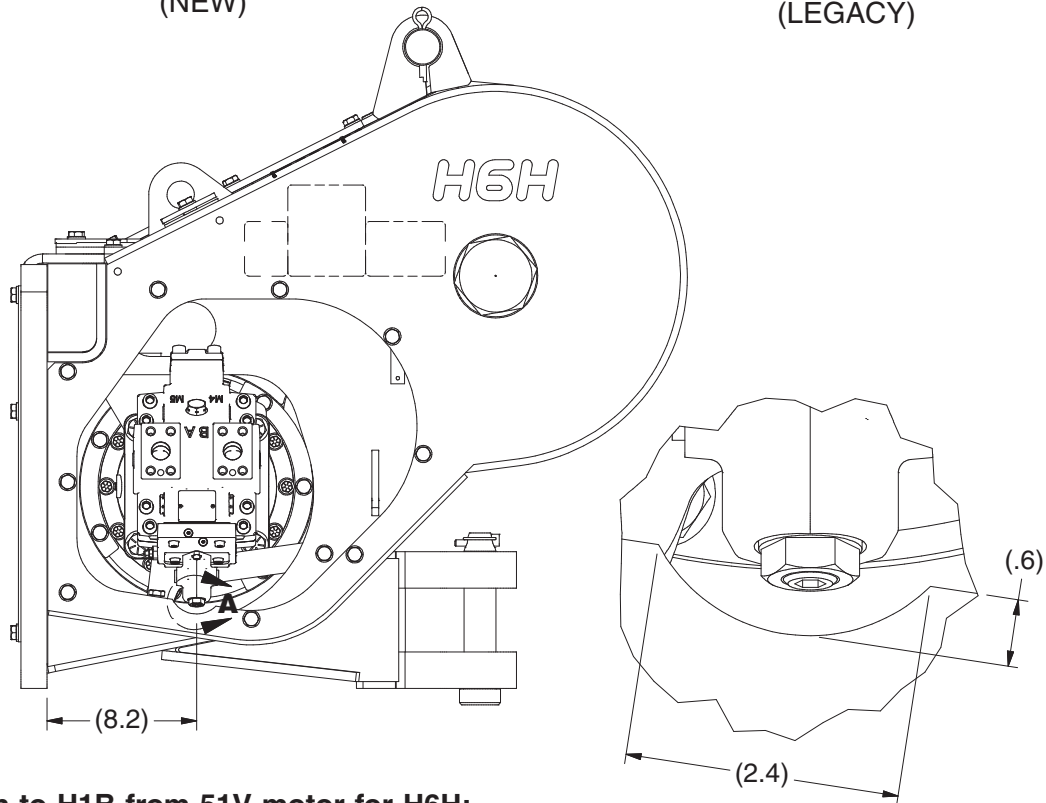

DETAIL A

Conversion to H1B from 51V motor for H6H:

1. Remove material from the winch frame as seen in Detail A to allow the new H1B motor to fit. More material may be removed if necessary for fit.
2. Material may be removed from the cover as necessary to allow the new motor to fit.

Shaft Assembly
BRAKE-OFF

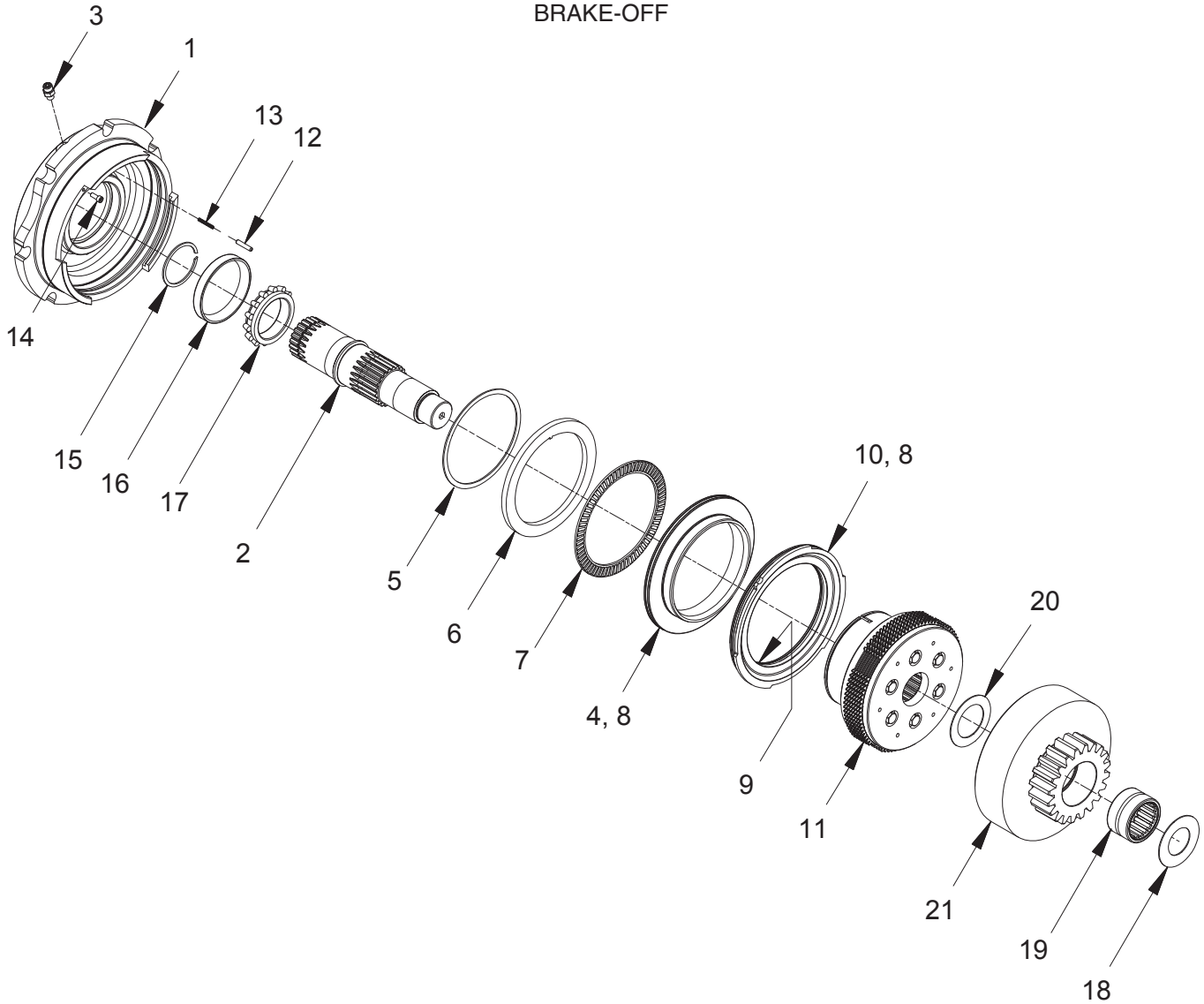

Item	Part No.	Qty	Description	Item	Part No.	Qty	Description
	2313026		Assy, BRAKE-OFF Shaft				
1	2311855	1	. Housing, Clutch	15	2311684	1	. Ring, Snap
2	2311856	1	. Shaft, Clutch	16	137153W	1	. Cup, Roller Bearing
3	231439	1	. Fitting	17	137155W	1	. Cone, Roller Bearing
4	2312039	1	. Piston, Clutch	18	2311869	1	. Shim .062
5	2311683	1	. Ring, Snap	19	230407W	1	. Bearing
6	2312442	1	. Ring, Thrust	20	2311687	1	. Shim .062
7	2311655	1	. Brg, Thrust Needle Roller	21	*b 2312977	1	. Gear, Spider
8	86585W	2	. O-Ring	21	*c 2311905	1	. Gear, Spider
9	87287W	1	. O-Ring				
10	2311880	1	. Ring, Seal				
11	*a 2311903	1	. Assy, Clutch	*a	See page 23 for details		
12	239147W	1	. Pin	*b	Gear ratios 2 & 5		
13	2303992W	1	. Spring	*c	Gear ratios 1 & 6		
14	R13811617	1	. Capscrew				

Clutch Assembly

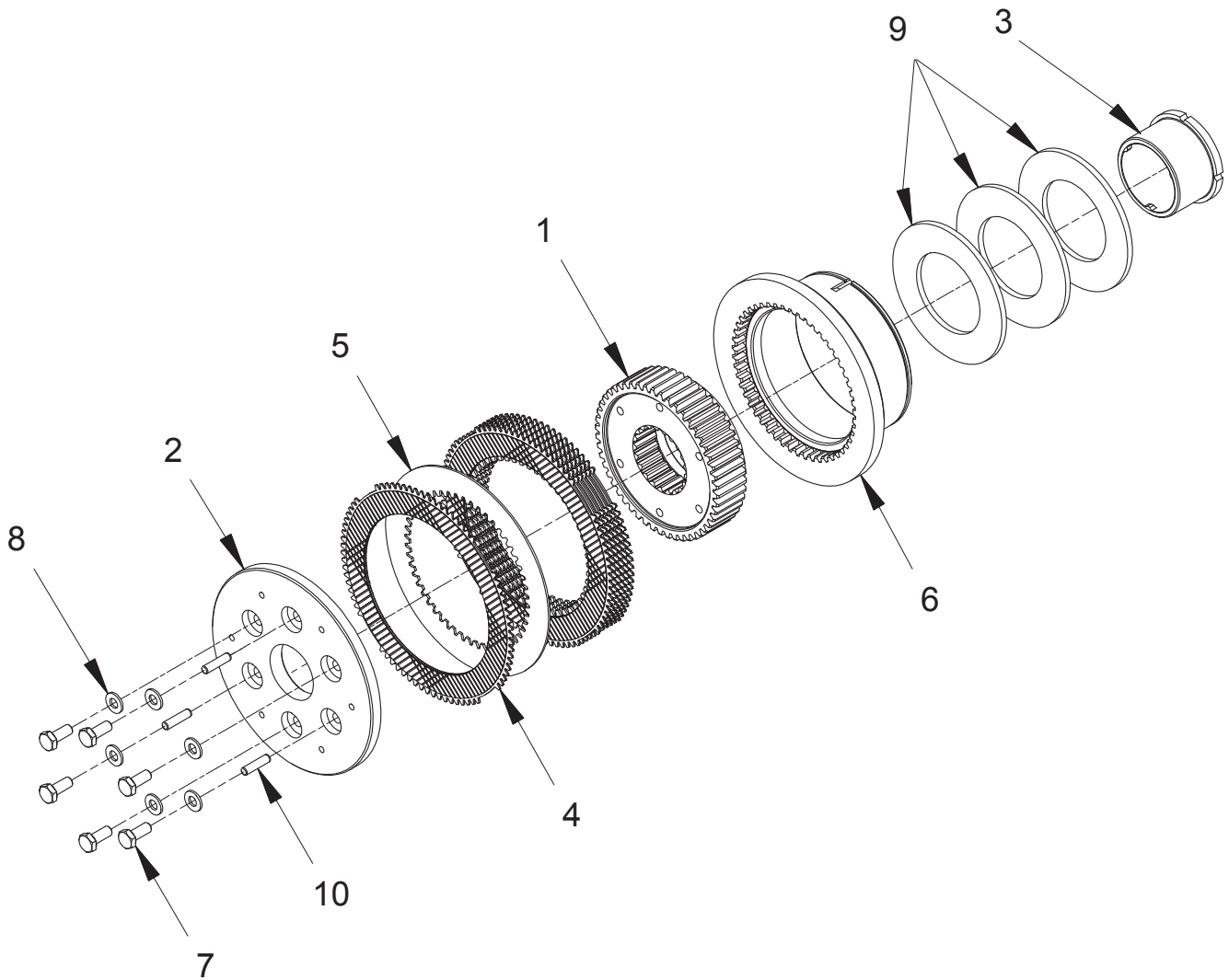

Item	Part No.	Qty	Description	Item	Part No.	Qty	Description
	2311903		Assy, Clutch	6	2311906	1	. Plate, Pressure
1	2311904	1	. Hub, Clutch	7	296420W	6	. Washer
2	2311907	1	. Plate, Clutch	8	293628W	6	. Capscrew
3	2312029	1	. Retainer, Spring	9	2311251	3	. Spring, Belleville
4	328715W	7	. Disc, Friction	10	222713W	3	. Pin
5	261542W	6	. Plate, Separator				

Dry Disc Brake

Page 1 of 2

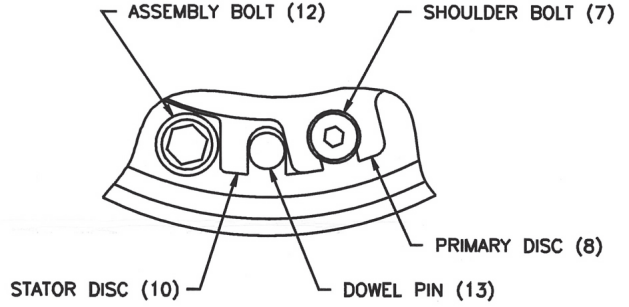
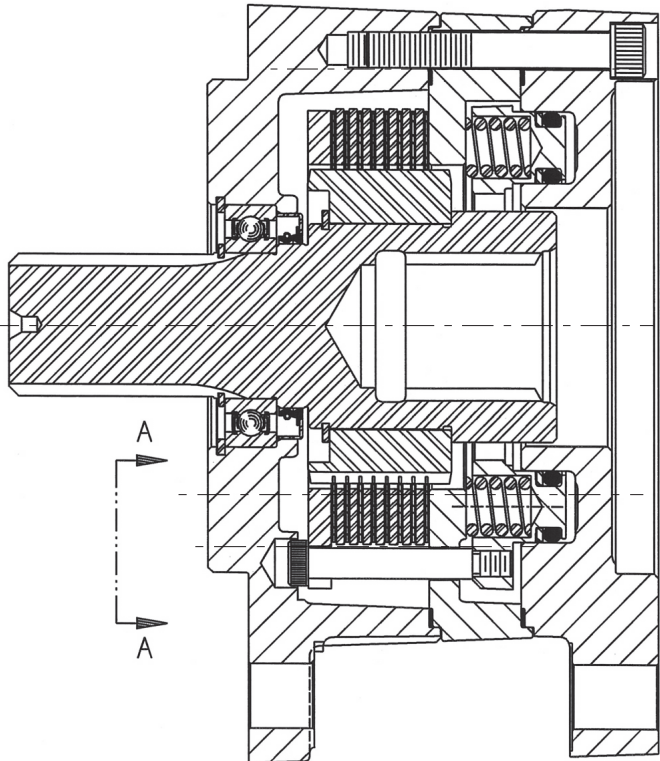
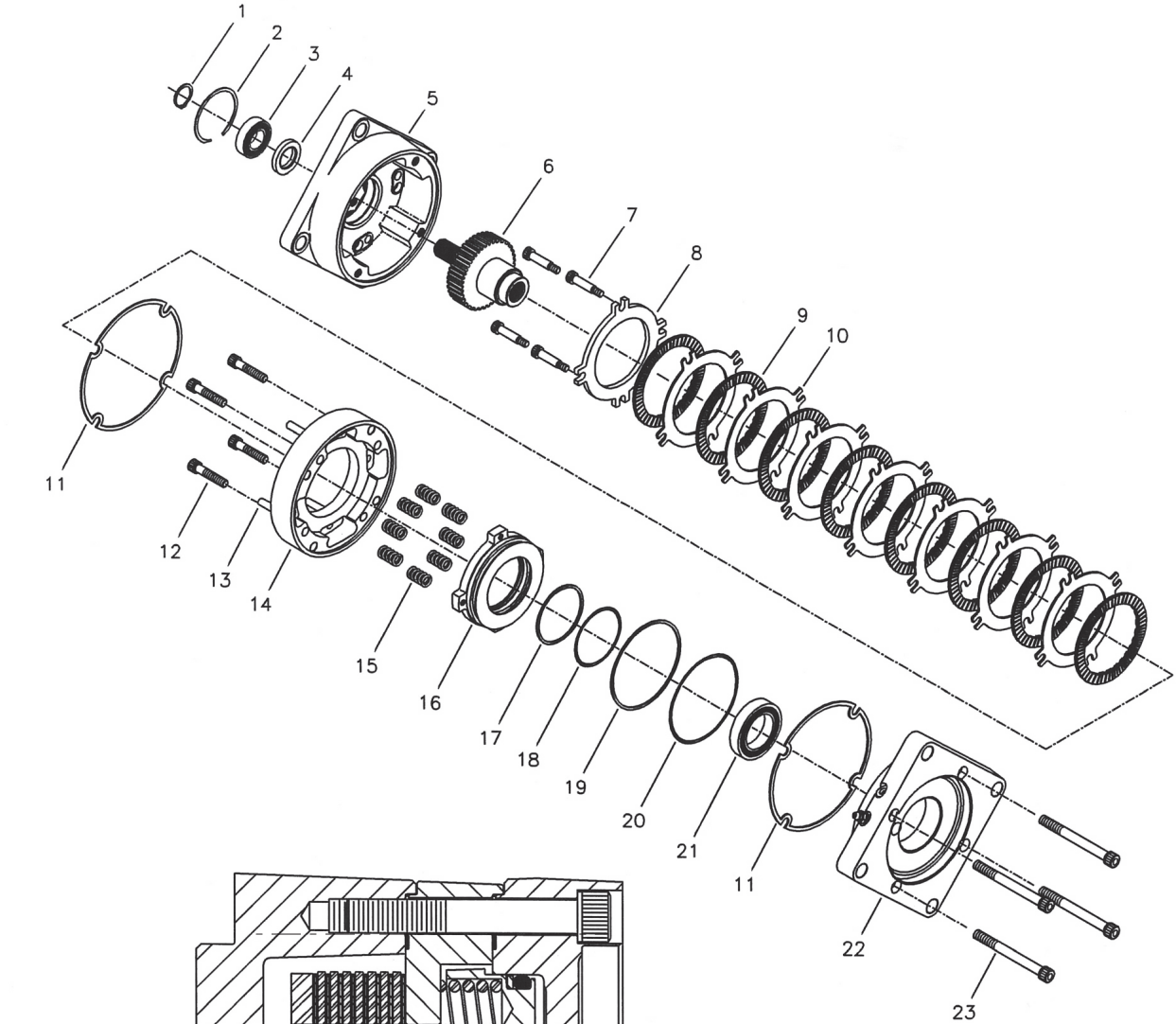

Dry Disc Brake

Page 2 of 2

Item	Part No.	Qty	Description	Item	Part No.	Qty	Description
	2312155		Brake, D Mount Dry Disc				
1	NSS	1	. Retaining Ring	21	*b NSS	1	. Bearing
2	NSS	1	. Retaining Ring	22	NSS	1	. Pressure Plate
3	*b NSS	1	. Bearing	23	NSS	4	. Capscrew
4	*a,*b NSS	1	. Oil Seal				
5	NSS	1	. Cover Plate		*a	Included in O-Ring Repair Kit 2312302; O-Ring Repair Kit 2312302 is included in Motor, Reducer & Brake Assembly Rebuild Kit 2314659	
6	NSS	1	. Spline Shaft Assy		*b	Included in Bearing Repair Kit 2312303; Bearing Repair Kit 2312303 is included in Intermediate/Drum Shaft & Brake Assembly Rebuild Kit 2314660	
7	NSS	4	. Bolt				
8	*d NSS	1	. Primary Disc		*c	Included in Spring Repair Kit 250850; Spring Repair Kit 250850 is included in Intermediate/Drum Shaft & Brake Assembly Rebuild Kit 2314660	
9	*d NSS	8	. Rotor Disc		*d	Included in Lining Repair Kit 250847; Lining Repair Kit 250847 is included in Intermediate/Drum Shaft & Brake Assembly Rebuild Kit 2314660	
10	*d NSS	7	. Stator Disc				
11	*a,*b,*c,*d NSS	2	. Case Gasket		NSS	Not Sold Separately	
12	NSS	4	. Capscrew				
13	NSS	4	. Dowel Pins				
14	NSS	1	. Spring Plate				
15	*c NSS	10	. Spring, Red				
16	NSS	1	. Piston				
17	*a NSS	1	. Backup Ring				
18	*a NSS	1	. O-Ring				
19	*a NSS	1	. Backup Ring				
20	*a NSS	1	. O-Ring				

Intermediate Gear Shaft

Without Freespool

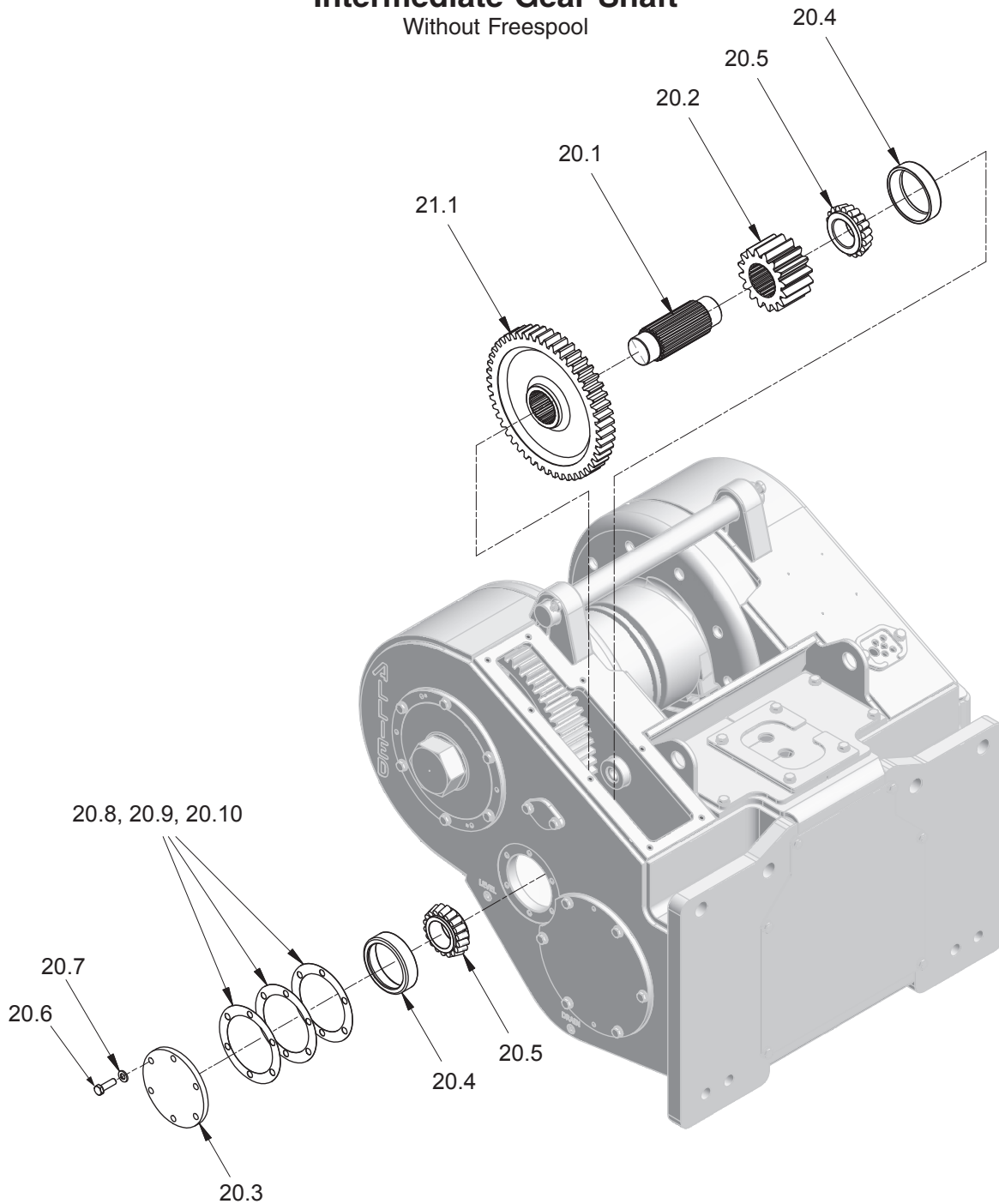

Item	Part No.	Qty	Description	Item	Part No.	Qty	Description
20.1	95972W	1	Shaft	20.10	149543W	AR	Shim .020
20.2	95973W	1	Gear	21.1	*b 96024W	1	Gear
20.3	280262W	1	Retainer, Bearing	21.1	*c 2314411	1	Gear
20.4	*a 30059W	2	Cup, Roller Bearing				
20.5	*a 30080W	2	Cone, Roller Bearing				
20.6	2312487	6	Capscrew				
20.7	296422W	6	Washer				
20.8	149541W	AR	Shim .005				
20.9	149542W	AR	Shim .007				
				*a	Included in Intermediate/Drum Shaft & Brake Assembly Rebuild Kit 2314660		
				*b	Gear ratios 1 & 6		
				*c	Gear ratios 2 & 5		
				AR	As Required. Refer to Service Manual 599040W for more information.		

Intermediate Gear Shaft With FREESPOOL

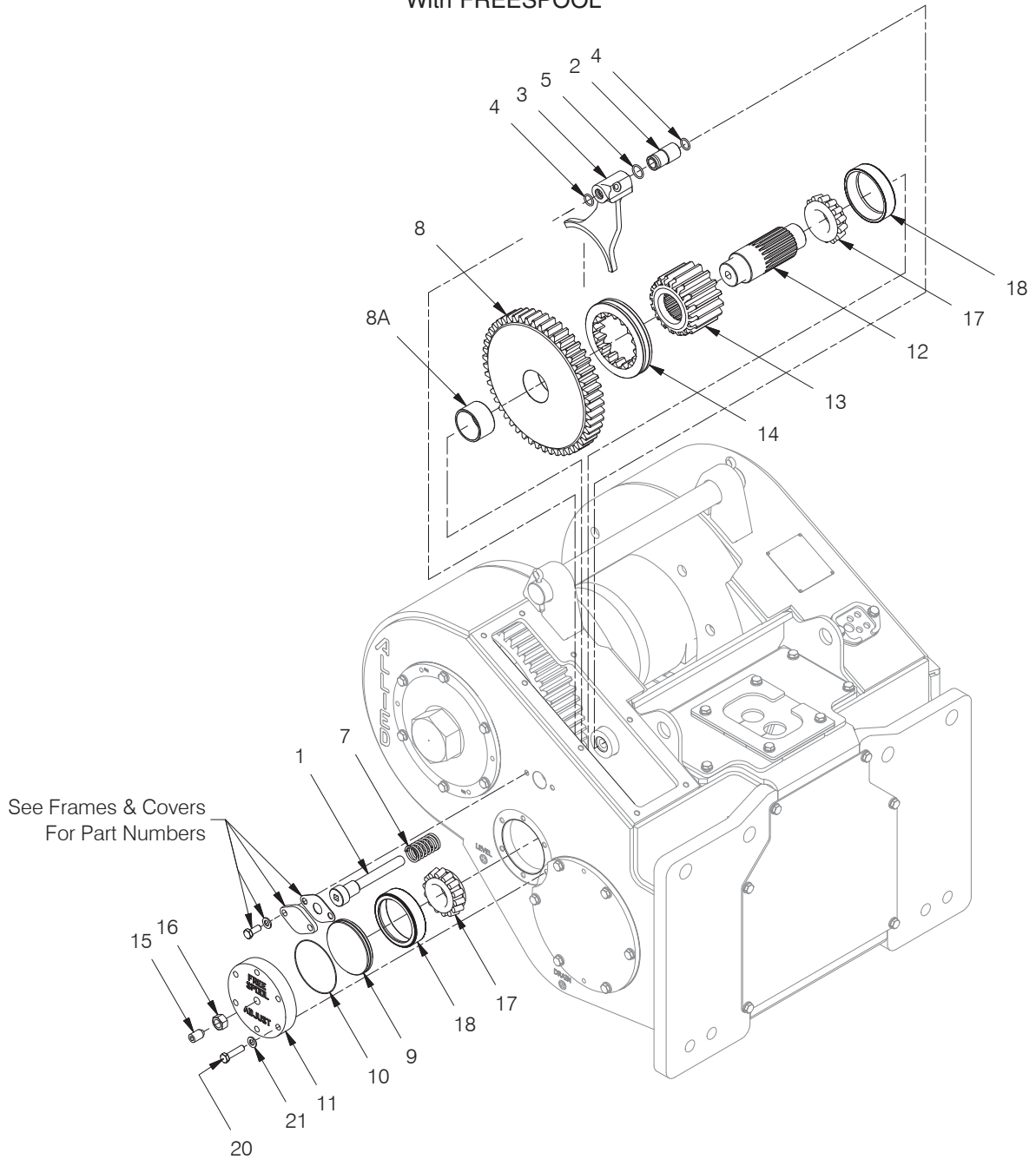

Item	Part No.	Qty	Description	Item	Part No.	Qty	Description
1	*a 2311894	1	Shaft, Freespool	14	2312269	1	Clutch, Dental
2	2305097W	1	Piston, Freespool	15	2304803W	1	Screw
3	2305099W	1	Shifter Fork, Freespool	16	221717W	1	Nut, Hex
4	*b 15862W	2	O-Ring	17	*b 2302311W	2	Cone, Bearing
5	*b 212380	1	O-Ring	18	*b 30059W	2	Cup, Bearing
7	2305096W	1	Spring	20	2312488	6	Capscrew
8	*c 283434W	1	Assy, Intermediate Gear	21	296422W	6	Washer, Hard
8	*d 2303036	1	Assy, Intermediate Gear				
8A	283432W	1	.Bushing	*a	Apply Threadlock 318702W to threads		
9	2302624W	1	Piston, Freespool Adjust	*b	Included in Intermediate/Drum Shaft & Brake Assembly Rebuild Kit 2314660		
10	*b 159940W	1	O-Ring	*c	Gear ratios 1 & 6		
11	2302625W	1	Housing, Freespool Adjust	*d	Gear ratios 2 & 5		
12	2305956W	1	Shaft, Intermediate				
13	2312280	1	Gear, Pinion				

Drum Shaft

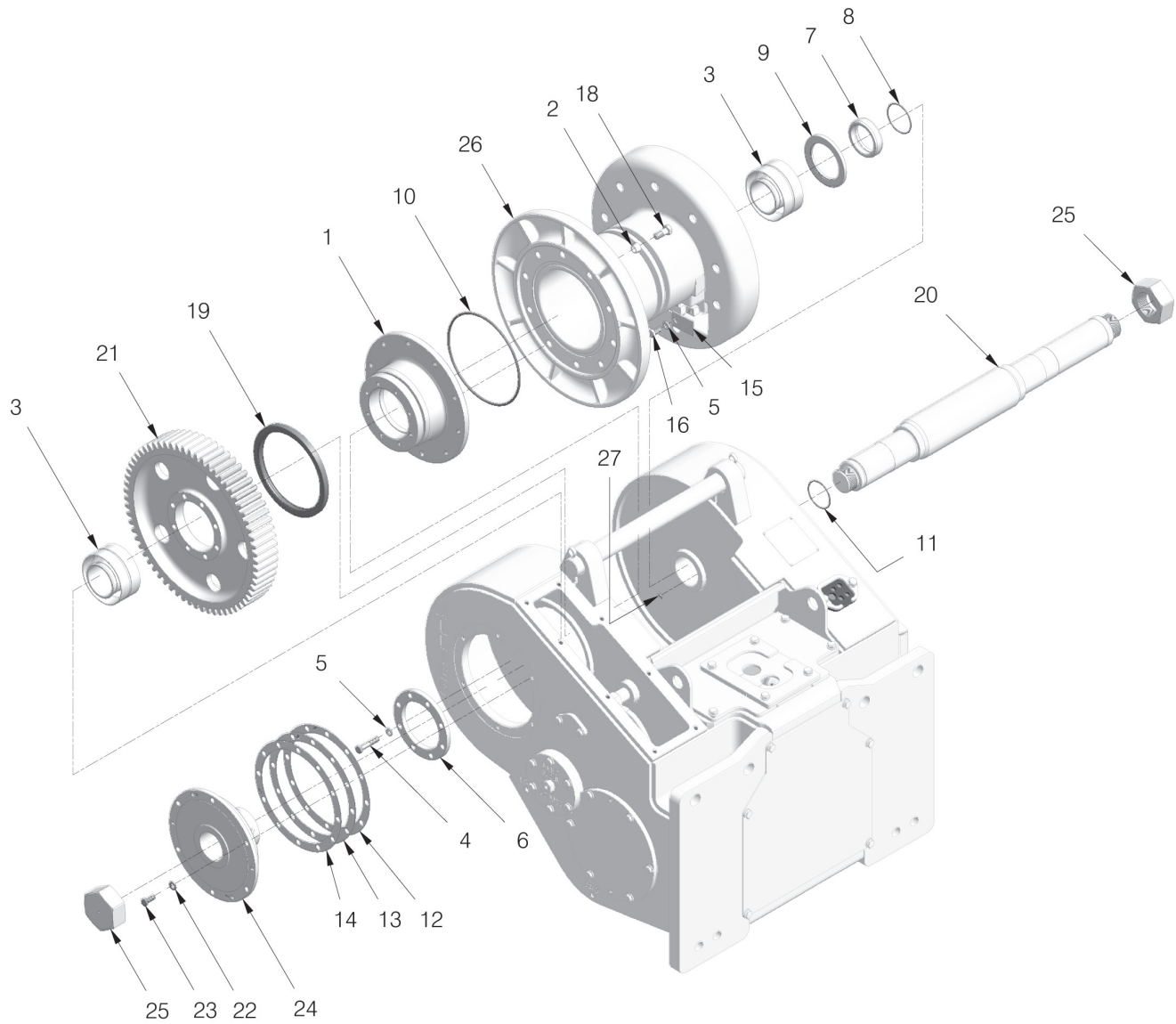

Item	Part No.	Qty	Description	Item	Part No.	Qty	Description
1	141674W	1	Adapter	17	221771W	8	Hard Washer
2	53559W	10	Thimble, Tapered	18	2310891	10	Capscrew
3	*b 2310093	2	Bearing, Roller	19	141671W	1	Seal, Oil
4	221577W	8	Capscrew	20	2312064	1	Shaft, Drum
5	*b 15158W	9	Washer	21	95977W	1	Gear, Drum
6	95978W	1	Retainer	22	296422W	6	Washer
7	*a 172808W	1	Spacer	23	2312486	6	Capscrew
8	15881W	1	O-Ring	24	172810W	1	Retainer
9	*b 44547W	1	Seal, Oil	25	*a 2312099	2	Nut
10	*b 133927W	1	Ring, Piston Seal	26	2313730	1	Drum, H6H
11	*b 90263W	1	O-Ring	27	Y433070.45	1	Fitting
12	175648W	AR	Shim, .020				
13	175647W	AR	Shim, .007				
14	175646W	AR	Shim, .005				
15	2301783W	1	Keeper, Ferrule	*a	Requires Sealant 358674W		
16	16829W	1	Capscrew	*b	Included in Intermediate/Drum Shaft & Brake Assembly Rebuild Kit 2314660		

Section 3
Hydraulic/Electrical Components

Hydraulic Group
 Shantui DH17 (H6HT**U47)
 Page 1 of 2

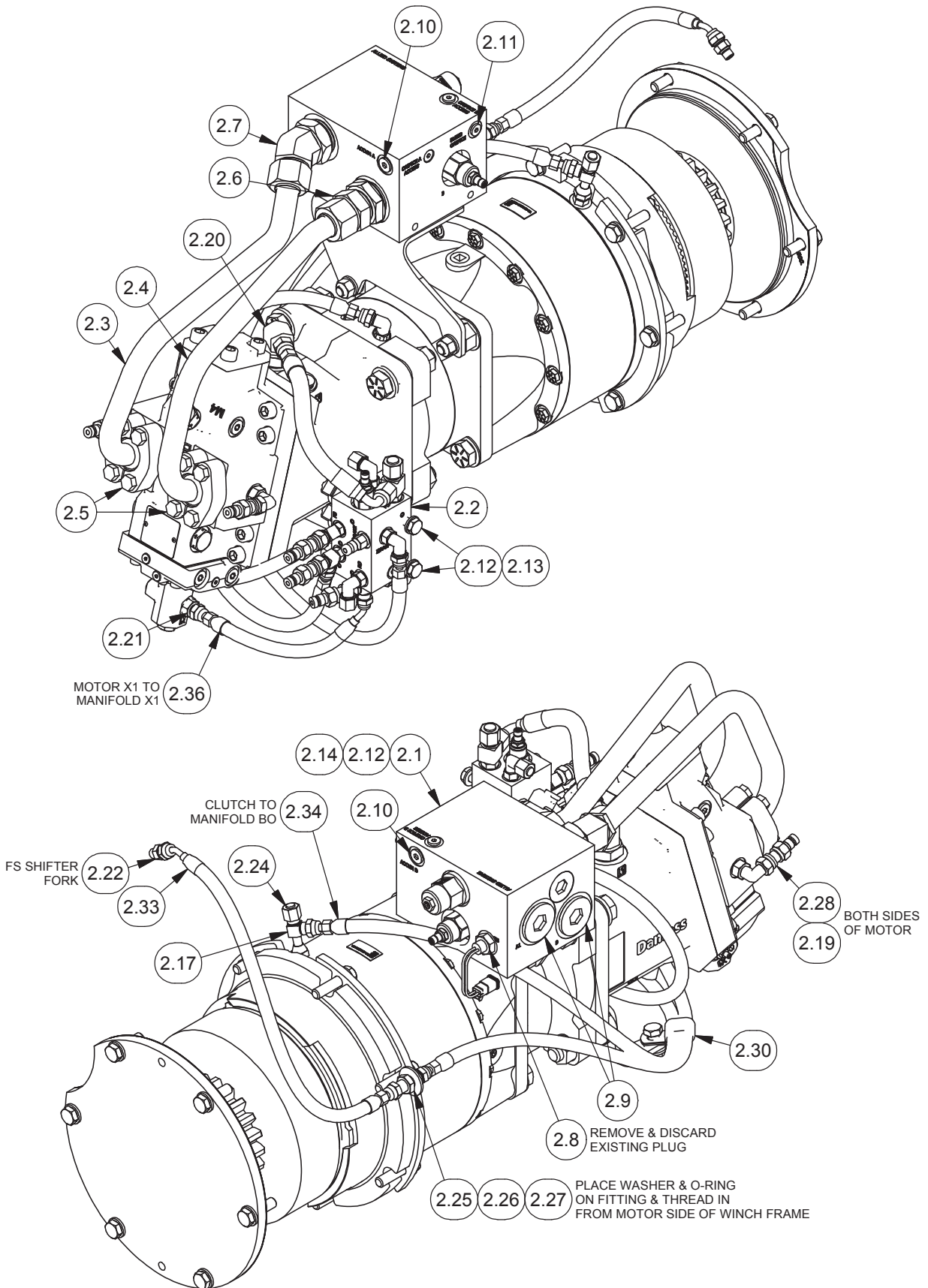

Hydraulic Group
 Shantui DH17 (H6HT**U47)
 Page 2 of 2

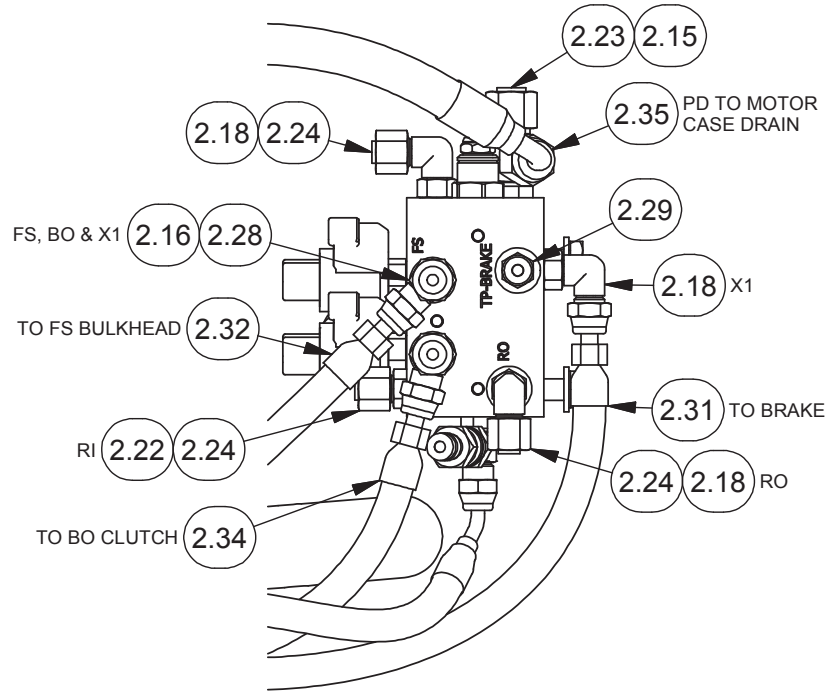

CONTROL MANIFOLD DETAIL

Item	Part No.	Qty	Description	Item	Part No.	Qty	Description
2.1	*a 2312941	1	Counterbalance Relief Manifold Assy	2.20	R833260	1	Fitting
2.2	*b 2311770	1	Manifold Assy	2.21	R833103	1	Fitting
2.3	2316108	1	Tube Assy - Motor A	2.22	231439	2	Fitting
2.4	2316109	1	Tube Assy - Motor B	2.23	231822	1	Fitting
2.5	592255	2	Kit, Split Flange	2.24	232984	4	Fitting
2.6	2313948	1	Fitting	2.25	R834100	1	Fitting
2.7	R833218	1	Fitting	2.26	15178W	1	Flat Washer
2.8	2307904W	1	Switch - Temperature	2.27	211564	1	O-Ring
2.9	229389	2	Fitting	2.28	2307625W	5	Fitting
2.10	229383	2	Fitting	2.29	R14040	1	Coupler, Male
2.11	235387	1	Fitting	2.30	2312628	1	Clamp
2.12	Y09C-M1025	4	Capscrew	2.31	2312353	1	Hose Assy
2.13	296420W	2	Hard Washer	2.32	2312350	1	Hose Assy
2.14	15176W	2	Flat Washer	2.33	2312212	1	Hose Assy
2.15	231465	1	Fitting	2.34	2312351	1	Hose Assy
2.16	R833400	3	Fitting	2.35	R12104	1	Hose Assy
2.17	236855	1	Fitting	2.36	2313639	1	Hose Assy
2.18	R833251	3	Fitting				
2.19	R833253	2	Fitting				

*a See page 32 for details
 *b See page 33 for details

Counterbalance Relief Manifold Assy

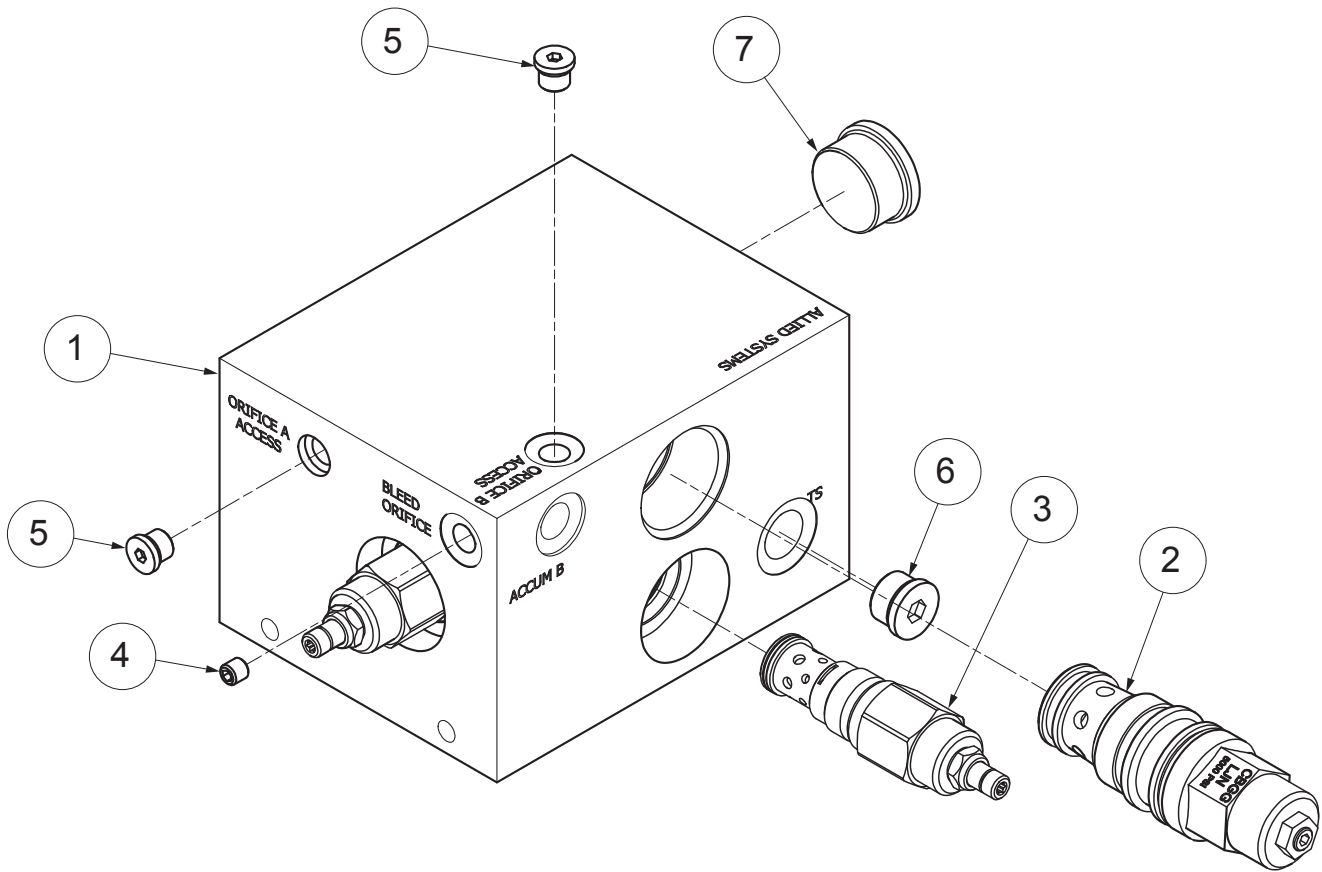

Item	Part No.	Qty	Description	Item	Part No.	Qty	Description
	2312941		Assembly - Manifold, Counterbalance Relief				
1	2312940	1	. Manifold - Body, Counterbalance Relief	4	2310181	1	. Plug
2	2312068	1	. Valve, Counterbalance	5	235387	3	. Fitting
	243815	1	.. Seal Kit	6	229345	1	. Fitting
3	2307438W	2	. Relief Valve	7	227949	1	. Fitting
	259258	1	.. Seal Kit				

Control Manifold Assy

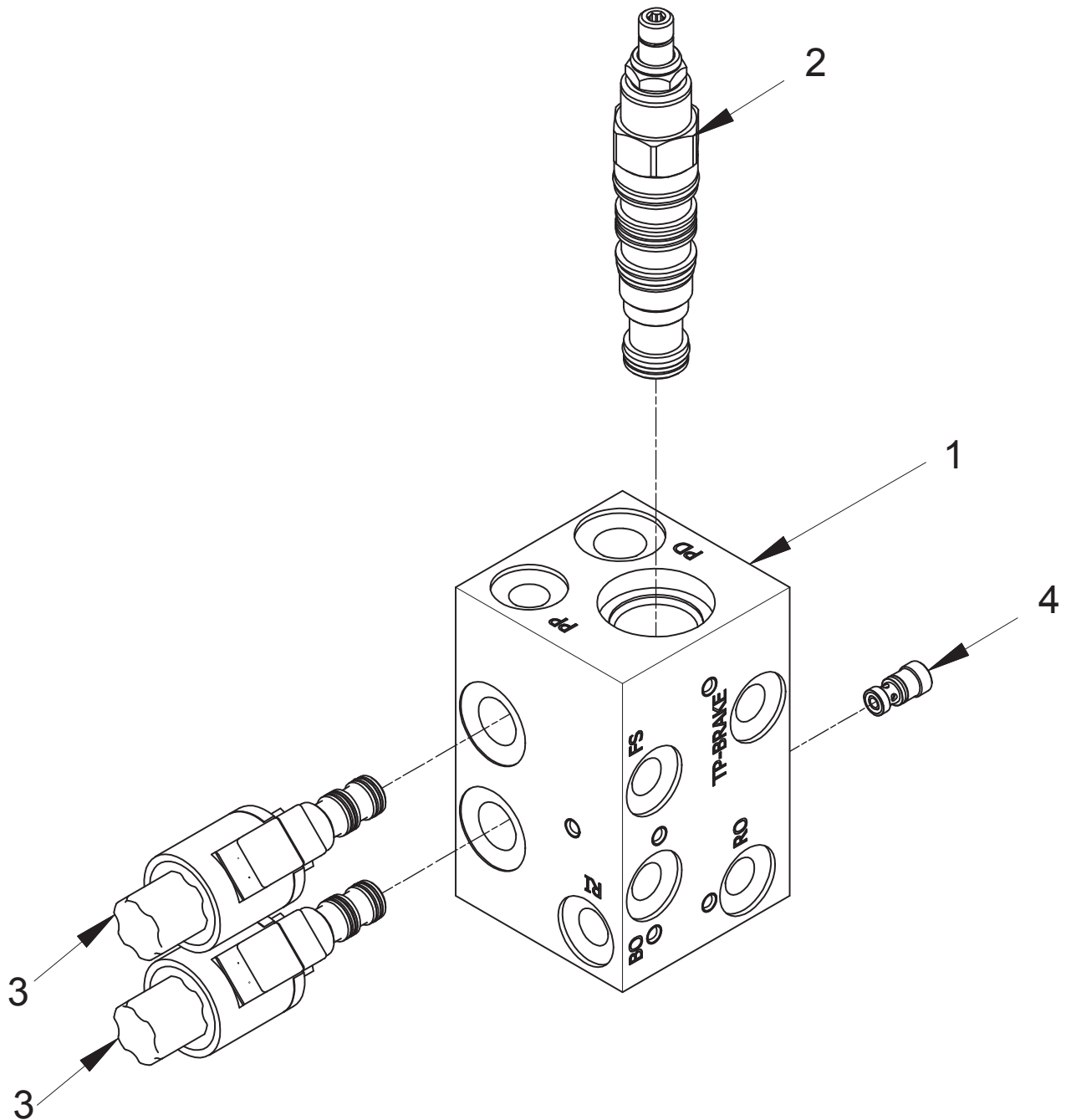

Item	Part No.	Qty	Description	Item	Part No.	Qty	Description
	2311770	1	Assy, Control Manifold				
1	2311771	1	. Body, Control Manifold	4	2312074	1	. Valve, Shuttle
2	2311592	1	. Valve, Directional		2312112	1	.. Seals, O-Ring
	252566	1	.. Kit, Seal				
3	2312073	2	. Valve, Cartridge				
	2314106	1	.. Base, Valve Cartridge				
	2313984	1	.. Coil				
	2312111	1	.. Kit, Seal				

Section 4
Optional Equipment

Arch

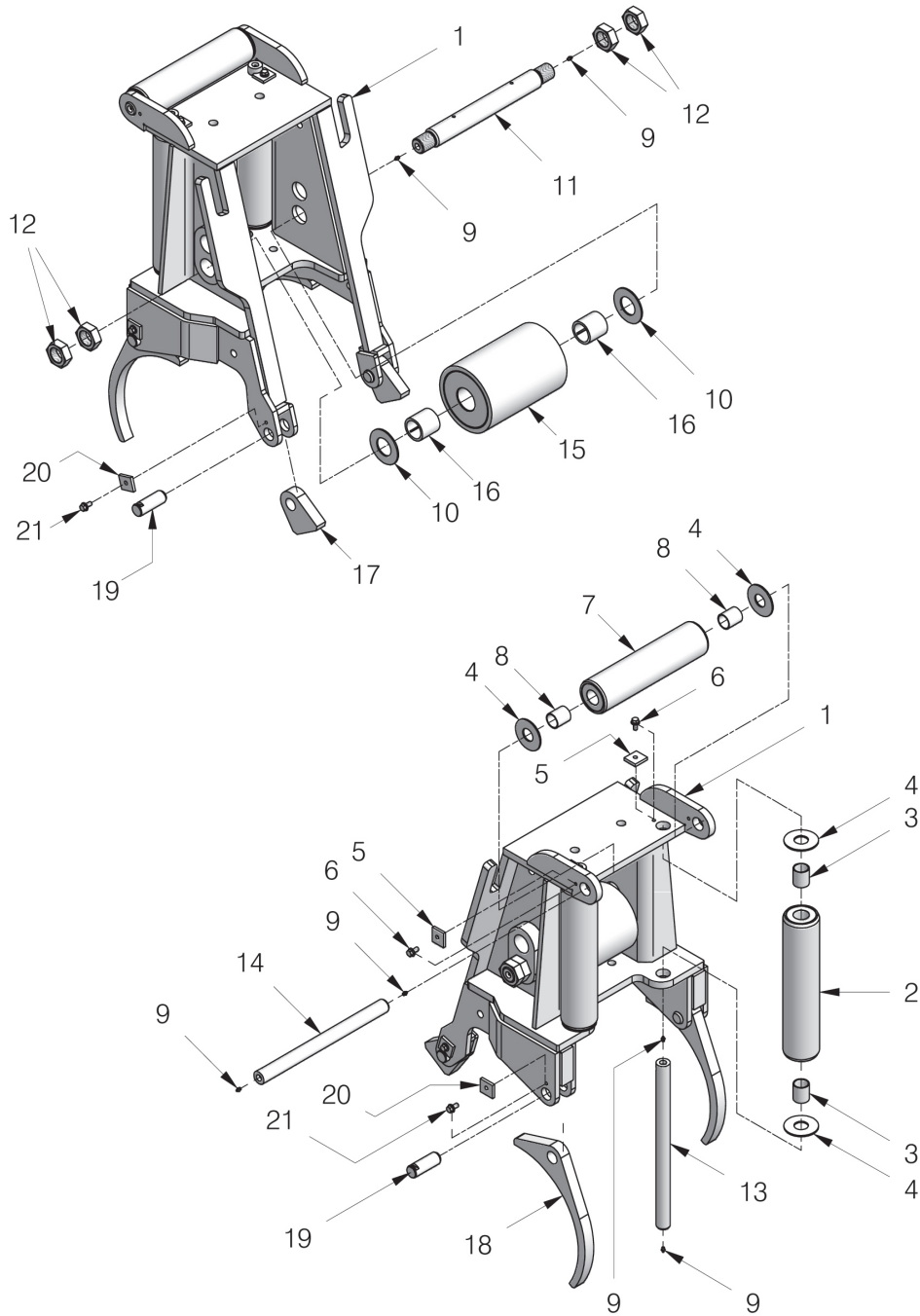

Item	Part No.	Qty	Description	Item	Part No.	Qty	Description
	2301748W	1	Arch Assembly				
1	2301749W	1	. Arch	12	221336W	4	. Nut
2	2301907W	2	. Roller	13	2301920W	2	. Shaft
3	35135W	2	. . Bushing	14	2301919W	1	. Shaft
4	331767W	6	. Washer	15	2301925W	1	. Roller
5	2301706W	3	. Keeper	16	2817W	2	. . Bushing
6	398817W	3	. Flange, Screw	17	2310726	2	Ear, Arch
7	2301910W	1	. Roller	18	2312168	2	Lug, Wrapped
8	35135W	2	. . Bushing	19	2301924W	4	Pin
9	16001W	8	. Fitting, Grease	20	2301706W	4	Keeper
10	2821W	2	. Washer	21	398817W	4	Flange Screw
11	2302120W	1	. Shaft				

Fairlead

3-Roller, Last Used S/N1609

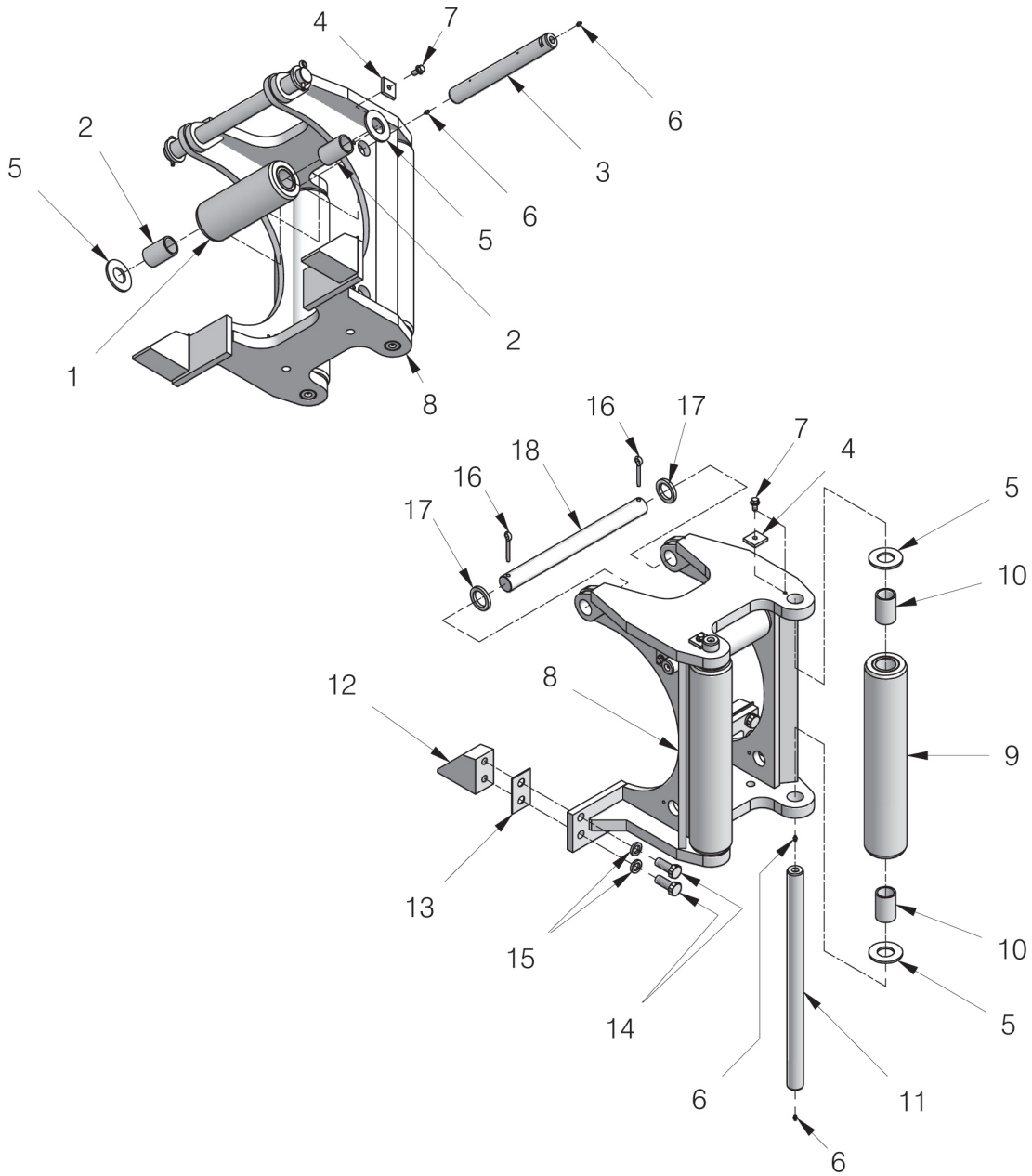

Item	Part No.	Qty	Description	Item	Part No.	Qty	Description
	2301731W		Fairlead Assembly, 3-Roller				
1	2301727W	1	. Roller	10	2570W	4	.. Bushing
2	2570W	2	.. Bushing	11	2301721W	2	. Shaft
3	2301722W	1	. Shaft	12	226374W	2	Bracket
4	2301706W	3	. Keeper	13	93878W	AR	Shim
5	33394W	6	. Washer	14	18669W	4	Cap screw
6	16001W	6	. Fitting, Grease	15	15166W	4	Washer
7	398817W	3	. Screw, Flange	16	15272W	2	Pin, Cotter
8	2301718W	1	. Fairlead	17	2312437	2	Spacer
9	2301726W	2	. Roller	18	2312580	1	Bar, Tie

Fairlead

3-Roller, First Used S/N1610

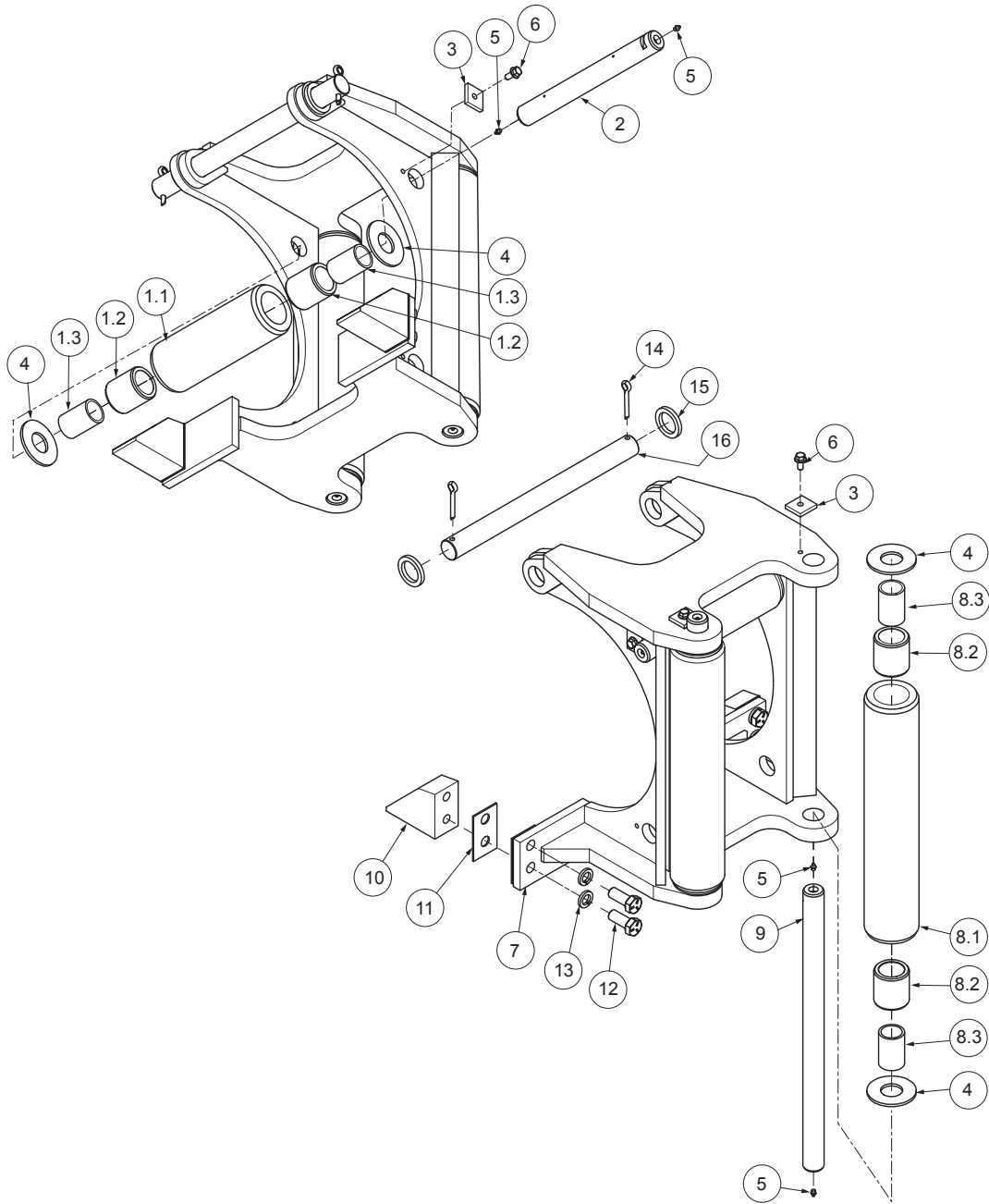

Item	Part No.	Qty	Description	Item	Part No.	Qty	Description
	2315548		Fairlead Assy, 3-Roller				
1	2315545	1	Roller Assy	8.1	2301724W	1	. Tube
1.1	2315544	1	. Tube	8.2	2301961W	2	. Spacer
1.2	2301961W	2	. Spacer	8.3	2570W	2	. Bushing
1.3	2570W	2	. Bushing	9	2301721W	2	Shaft, Vertical
2	2315546	1	Shaft	10	226374W	2	Bracket - Fairlead
3	2301706W	3	Keeper	11	93878W	8	Shim
4	2314097	6	Washer	12	18668W	4	Capscrow
5	16001W	6	Fitting, Lube	13	15166W	4	Washer
6	398817W	3	Screw, Flange	14	15272W	2	Cotter Pin
7	2315555	1	Frame, Fairlead	15	173607W	2	Spacer
8	2301726W	2	Roller Assy	16	2312580	1	Rod - Tie

Fairlead

4-Roller, Last Used S/N1609

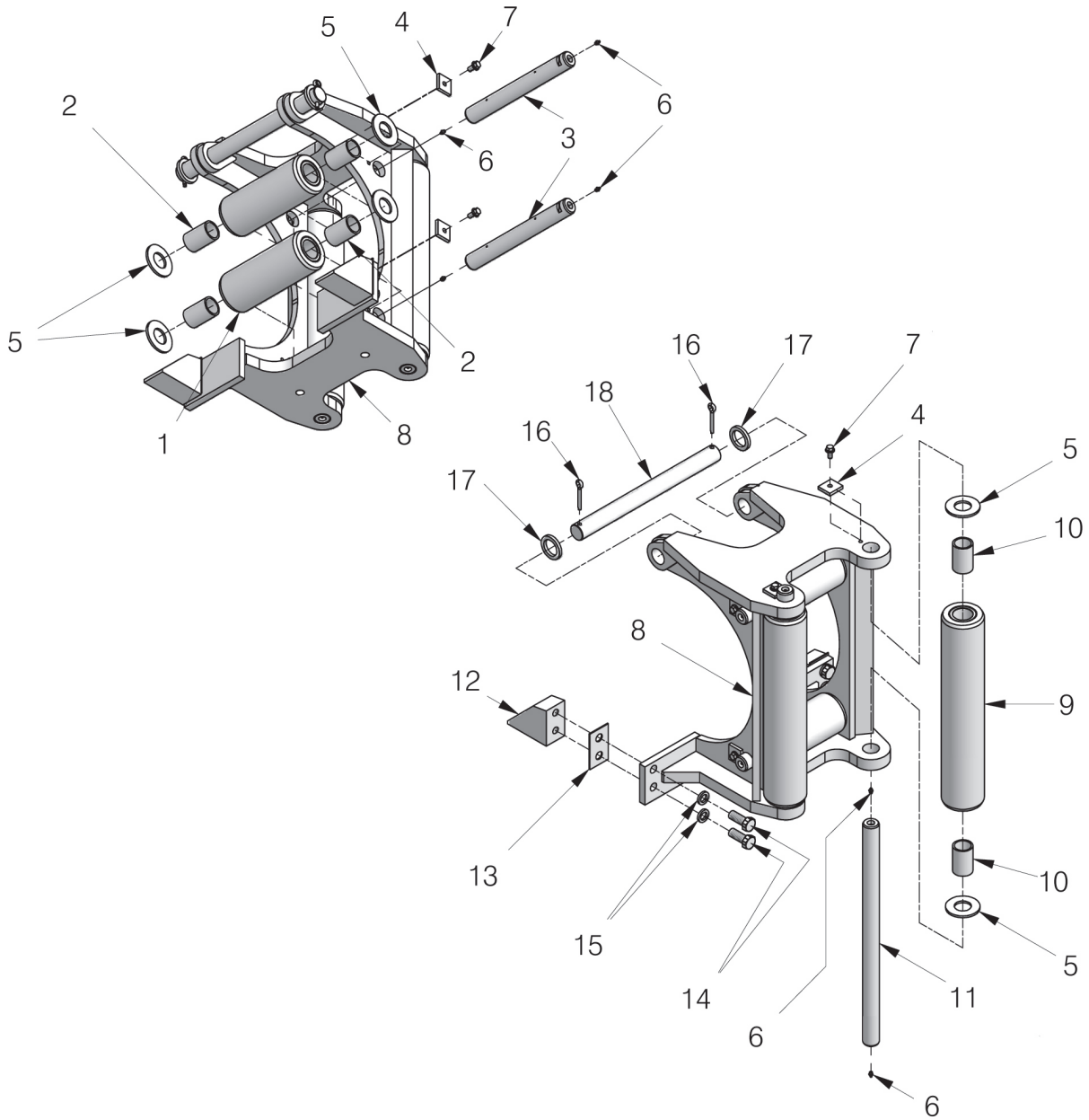

Item	Part No.	Qty	Description	Item	Part No.	Qty	Description
	2301732W		Fairlead Assy, 4-Roller				
1	2301727W	2	. Roller	10	2570W	4	. . Bushing
2	2570W	4	. . Bushing	11	2301721W	2	. Shaft
3	2301722W	2	. Shaft	12	226374W	2	Bracket
4	2301706W	4	. Keeper	13	93878W	AR	Shim
5	33394W	8	. Washer	14	18668W	4	Capscrew
6	16001W	8	. Fitting, Grease	15	15166W	4	Washer
7	398817W	4	. Screw, Flange	16	15272W	2	Pin, Cotter
8	2301718W	1	. Fairlead	17	2312437	2	Spacer
9	2301726W	2	. Roller	18	2312580	1	Bar, Tie

Fairlead

4-Roller, Wide, First Used S/N1610

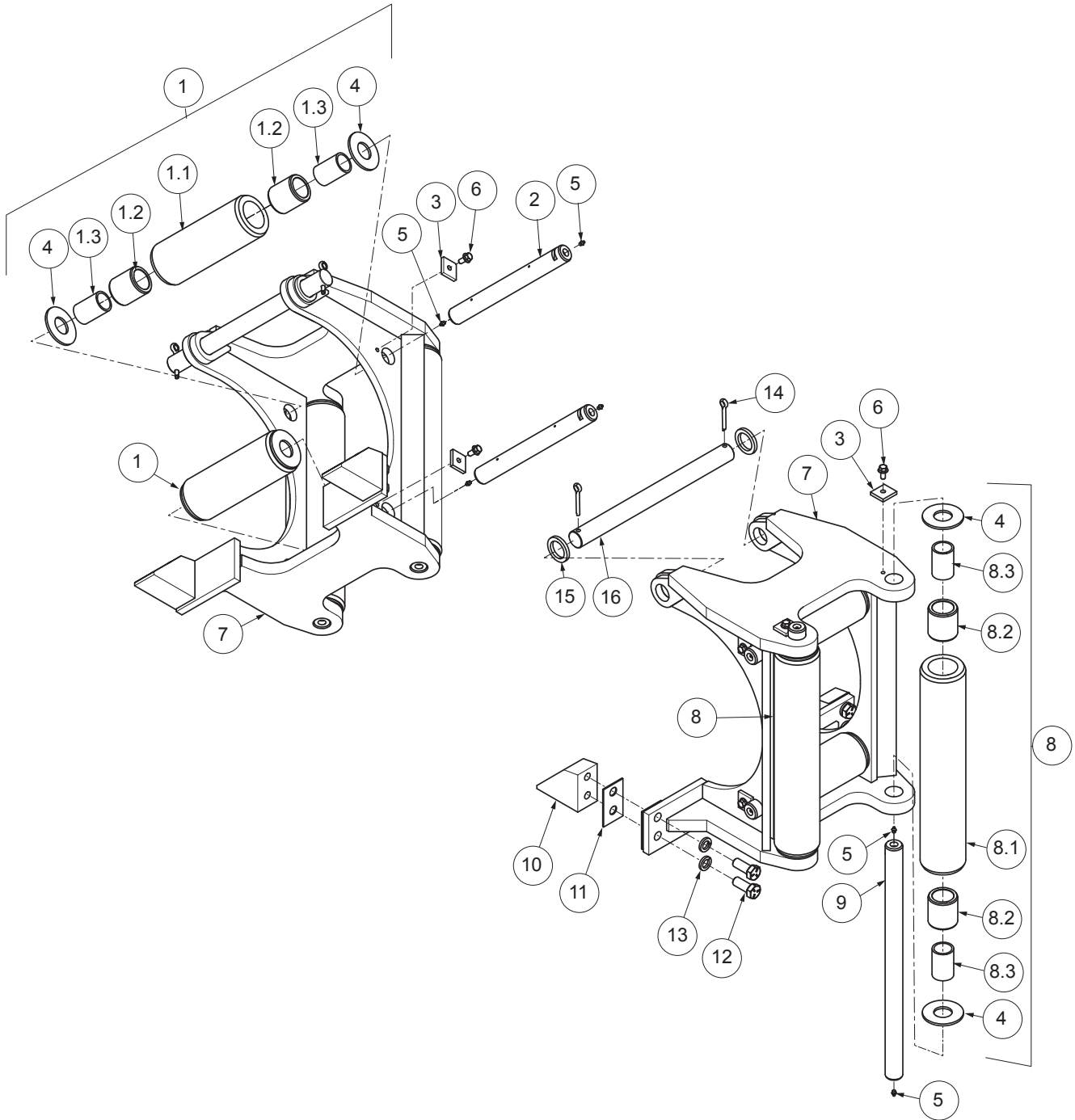

Item	Part No.	Qty	Description	Item	Part No.	Qty	Description
	2315549		Fairlead Assy, 4-Roller				
1	2315545	2	Assy, Roller	8.1	2315544	1	. Tube
1.1	2315544	1	. Tube	8.2	2301961W	2	. Spacer
1.2	2301961W	2	. Spacer	8.3	2570W	2	. Bushing
1.3	2570W	2	. Bushing	9	2301721W	2	Shaft, Vertical
2	2315546	2	Shaft	10	226374W	2	Bracket, Fairlead
3	2301706W	4	Keeper	11	93878W	8	Shim
4	2314097	8	Washer	12	18668W	4	Capscrew
5	16001W	8	Fitting, Lube	13	15166W	4	Washer
6	398817W	4	Screw, Flange	14	15272W	2	Cotter Pin
7	2315555	1	Frame, Fairlead	15	173607W	2	Spacer
8	2301726W	2	Assy, Roller	16	2312580	1	Bar, Tie

Wire Rope Assemblies

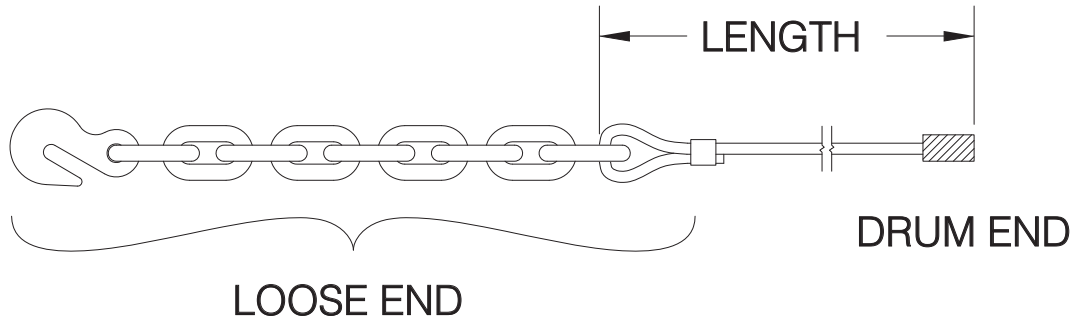

Figure A

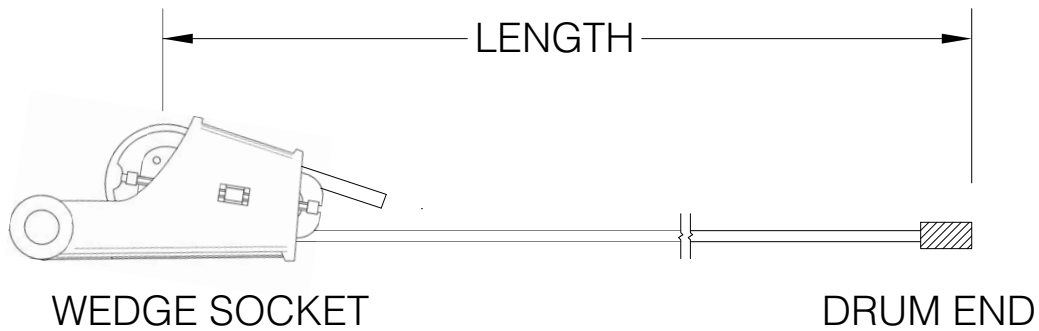

Figure B

Part No.	Wire Diameter	Length Ft (M)	Part No.	Wire Diameter	Length Ft (M)
WR6-275L	*a 3/4"	275 (84) *c	WR8-154L	*a 1"	154 (47) *c
WR6-413L	*a 3/4"	413 (126) *d	WR8-230L	*a 1"	230 (70) *d
YS6-275LWS	*b 3/4"	275 (84) *c	YS8-154LWS	*b 1"	154 (47) *c
YS6-413LWS	*b 3/4"	413 (126) *d	YS8-230LWS	*b 1"	230 (70) *d
WR7-198L	*a 7/8"	198 (60) *c			
WR7-297L	*a 7/8"	297 (91) *d			
YS7-198LWS	*b 7/8"	198 (60) *c			
YS7-297LWS	*b 7/8"	297 (91) *d			

*a WR Series Wire Rope (Illustrated in Figure A)
 *b YS Series Wire Rope (Illustrated in Figure B)
 *c Length to fill drum to 2/3 capacity (recommended)
 *d Length to fill drum to full capacity

Section 5
Service Kits

Recommended Winch Service Intervals and Kits

Following the service schedule recommended here to help keep dozer winch downtime to a minimum, optimize winch operation, and extend the life of your investment.

See Table 1 for recommended service intervals, and Table 2 for recommended service kits.

Hydraulic Winch Maintenance					
Recommended Winch Service Intervals					
Hours or **	Months **	Filter ***	Winch Gear Oil	Brake & Clutch	Major Overhaul
First 250	1	Change			
Every 500	3	Change			
Every 2,000	12		Change		
Every 5,000				*Inspect	
Every 10,000					*Evaluate
Lube rollers and check oil level and filter light every week.					
<p>* Evaluate = Service based on average winch use; If used more than once a day, perform an overhaul. If used less than once a day, remove covers and check to determine need.</p> <p>* Inspect = Disassemble and inspect for wear.</p> <p>** Service winch using the dozer's hour meter or the length of time the winch is mounted to the dozer, whichever occurs first.</p> <p>*** Follow dozer schedule if using dozer filter.</p>					
Recommended Gear Compartment Oil					
Chevron	Drive Train Fluids HD	Consult service/operating manual for low temperature oils and other details. Use of non-recommended oil may void the warranty.			
ExxonMobil	Mobiltrans HD Series				

Table 1 Recommended Winch Service Intervals

Service Kits for H6H Winches				
Service Description	Kit Description	Winch Serial Number	Kit Part# for Hi-Performance (H) Winches	Kit Part# for Standard (T) Winches
Filter change	Filter kit	All	Refer to dozer operator and service manuals	
Complete oil change (every 1,000 hours)	N/A	All	Check our website for current operator's and service manuals for appropriate oils	
Clutch and brake overhaul (every 5,000 hours)	Motor, reducer & brake assembly rebuild kit	All	2314659	
Major overhaul (every 10,000 hours)	Intermediate/drum shaft & brake assembly rebuild kit	All	2314660	

Table 2 Routine Maintenance Kits

Motor, Reducer & Brake Assembly Rebuild Kit: 2314659

Page 1 of 2

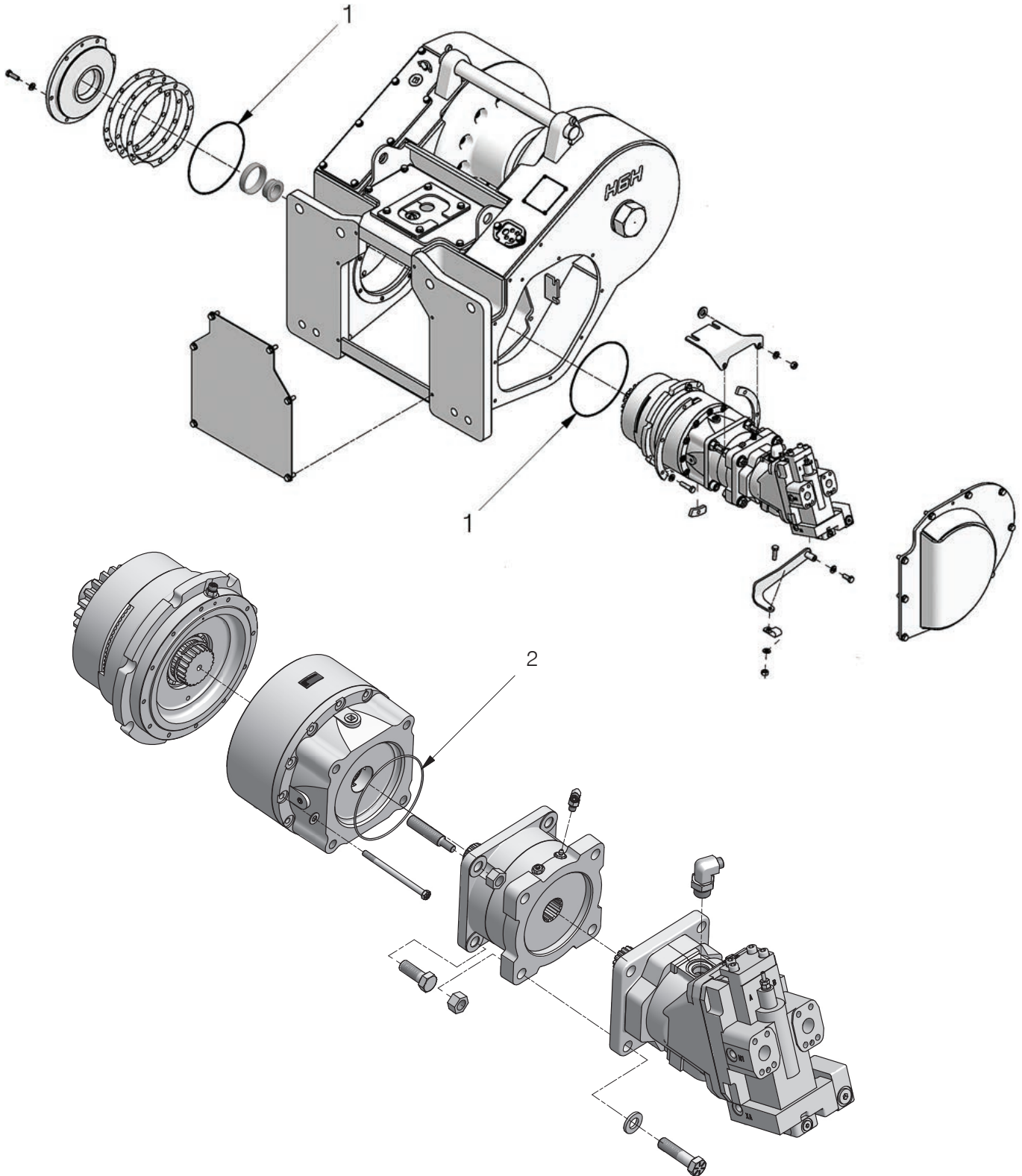

Motor, Reducer & Brake Assembly Rebuild Kit: 2314659

Page 2 of 2

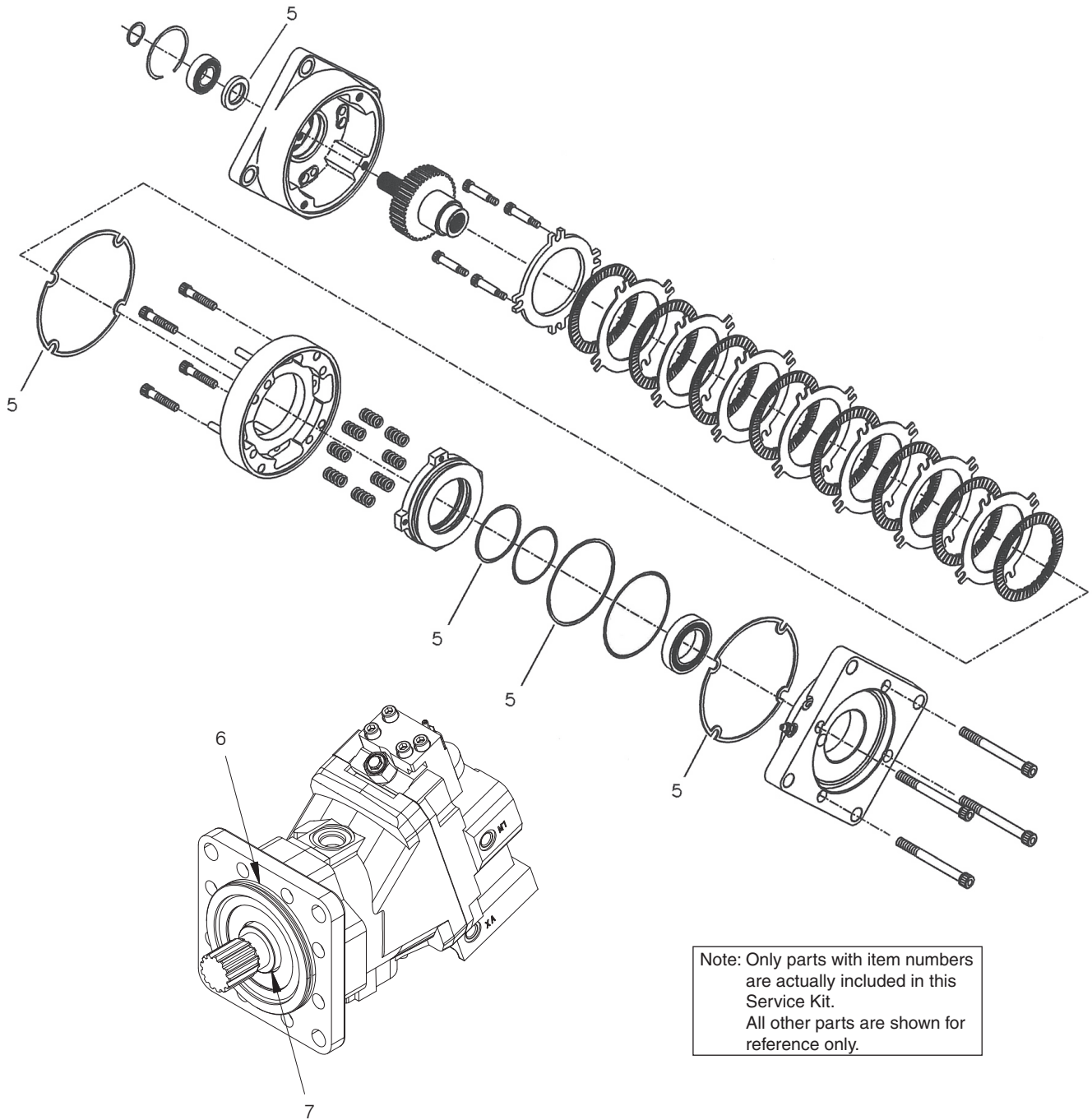

Item	Part No.	Qty	Description	Item	Part No.	Qty	Description
	2314659		Rebuild Kit, Motor, Reducer & Brake Assy				
1	203564	2	. O-Ring	4	230064W	1	. Adhesive (Not Shown)
2	237349	1	. O-Ring	5	2312302	1	. Kit, O-Ring
3	313022W	1	. Adhesive (Not Shown)	6	2313890	1	. O-Ring
				7	2313891	1	. Kit, Shaft Seal

Intermediate/Drum Shaft & Brake Assembly Rebuild Kit: 2314660

Page 1 of 4

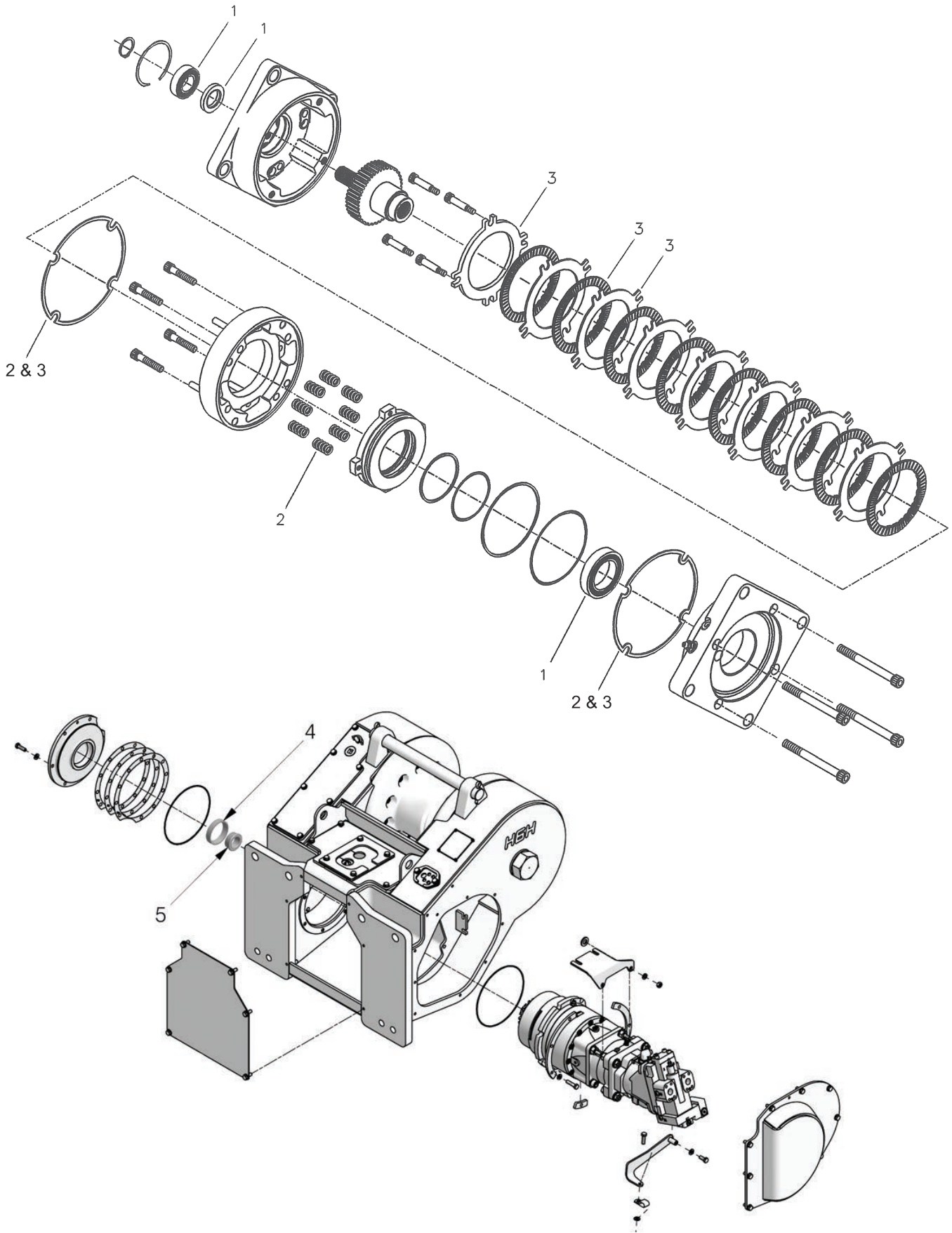

Intermediate/Drum Shaft & Brake Assembly Rebuild Kit: 2314660

Page 2 of 4

Without FREESPOOL

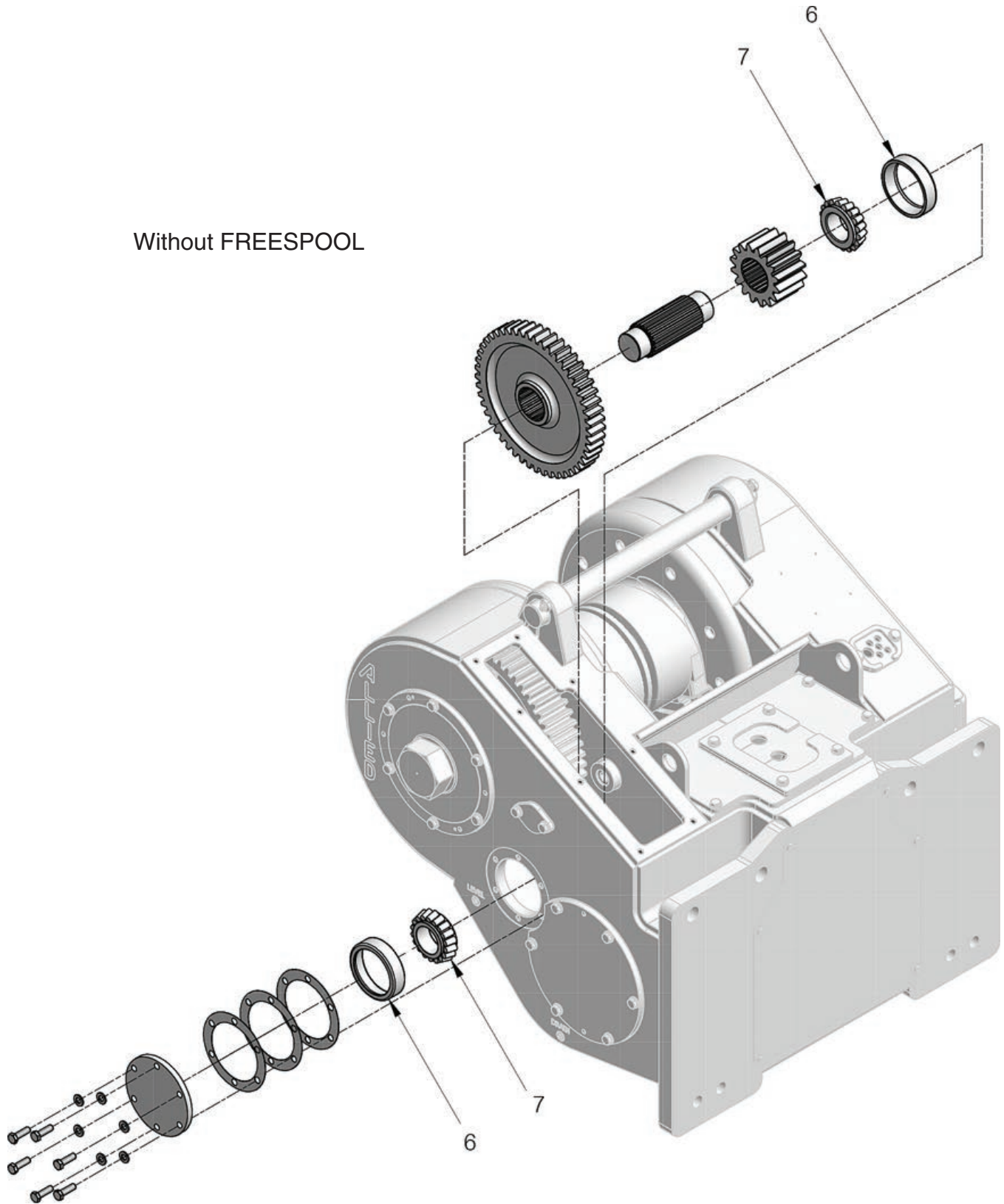

Intermediate/Drum Shaft & Brake Assembly Rebuild Kit: 2314660

With FREESPOOL

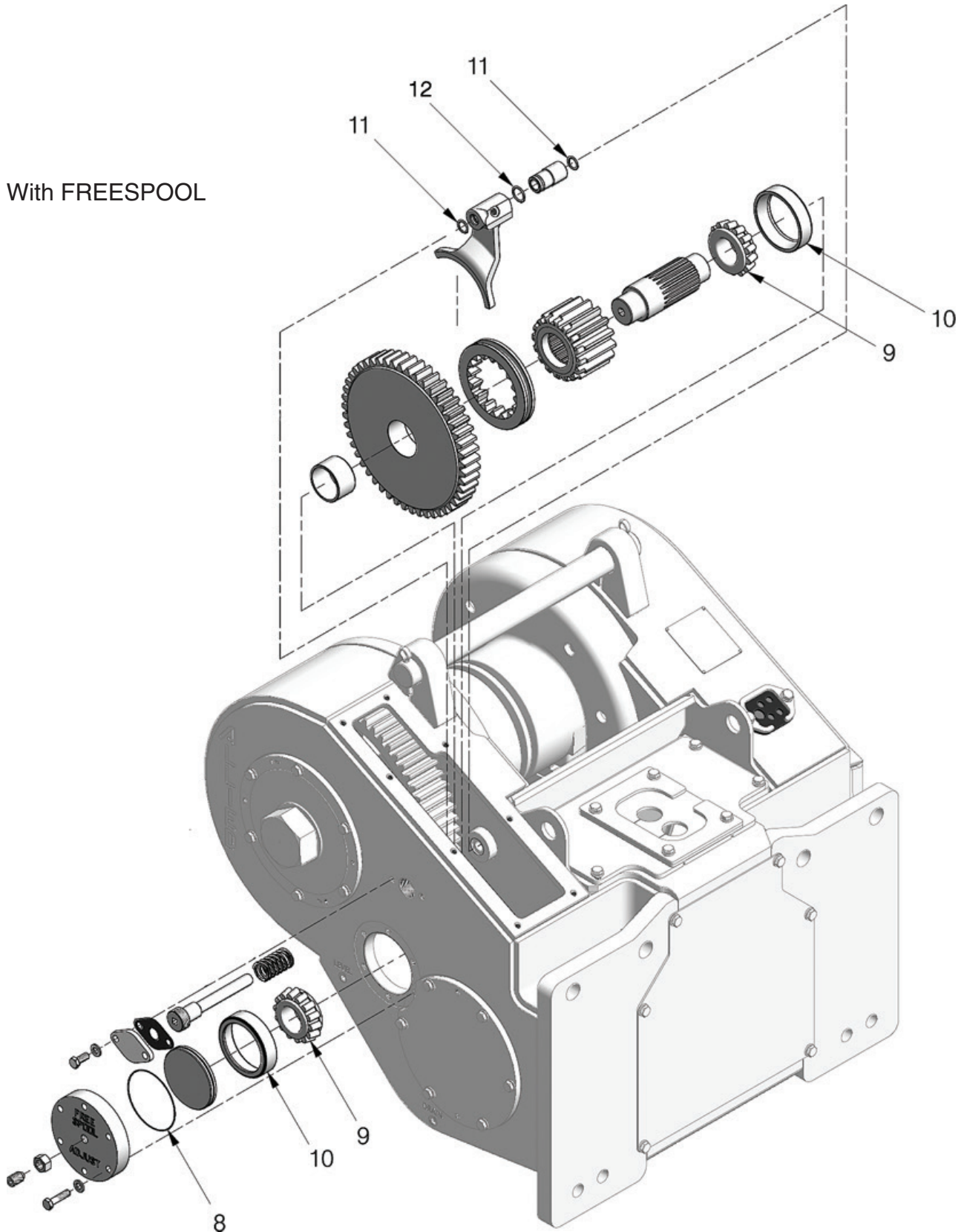

Intermediate/Drum Shaft & Brake Assembly Rebuild Kit: 2314660

Page 4 of 4

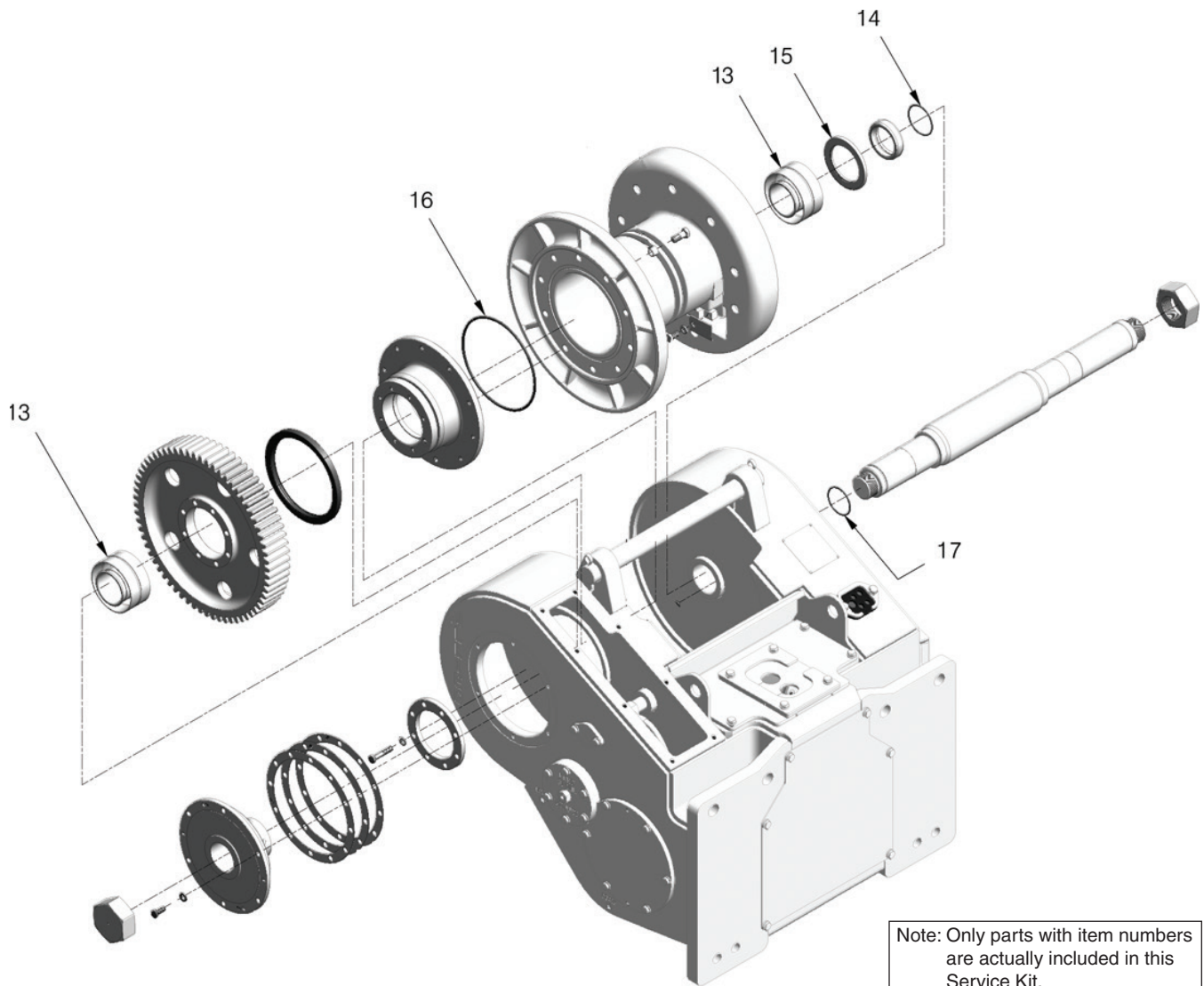

Note: Only parts with item numbers are actually included in this Service Kit. All other parts are shown for reference only.

Item	Part No.	Qty	Description	Item	Part No.	Qty	Description
	2314660		Rebuild Kit, Intermediate/ Drum Shaft & Brake Assy				
1	2312303	1	. Repair Kit, Bearing	10	30059W	2	. Cup, Bearing
2	250850	1	. Repair Kit, Spring	11	15862W	2	. O-Ring
3	250847	1	. Repair Kit, Lining	12	212380	1	. O-Ring
4	2300668W	1	. Cup, Bearing	13	230406W	2	. Bearing, Roller
5	2300669W	1	. Cone, Bearing	14	15881W	1	. O-Ring
6	30059W	2	. Cup, Bearing	15	44547W	1	. Seal, Oil
7	30080W	2	. Cone, Bearing	16	133927W	1	. Ring, Piston Seal
8	159940W	1	. O-Ring	17	90263W	1	. O-Ring
9	2302311W	2	. Cone, Bearing				

Section 6
Recommended Service Parts

H6H Hydraulic Winch Recommended Service Parts

The following pages list some of the service parts and kits that are available for your Allied H6H Winch.

Page 51 lists gaskets and seals. Keep these parts in stock at all times for regular maintenance.

Page 51 and page 52 contain kits for 5,000 hour and 10,000 hour scheduled maintenance. Order these kits in preparation for these intervals. Each kit includes all parts listed in the table. Order parts from the table based on your winch.

Page 52 is a list of wire rope assemblies. Order parts as required and as relevant for your installation.

Page 53 contains a list of spare parts. Order parts or kits as required and as relevant for your installation.

Page 53 contains lists of operator controls components. Order parts or kits as required and as relevant for your installation.

Page 54 contains lists of tool kits and diagnostic tools, which are useful when you install, maintain and service your winches.

Note: Allied Winch parts manuals are available for no charge download at <http://www.alliedsystems.com/pubs/pubs.htm>.

Gaskets & Seals				Order as Required
Applies to: H6H Standard Winch mounted on Shantui DH17 (U47)				
Allied P/N	Description	Qty on Winch	See Parts Manual Page	Order Qty
2312045	Gasket, Top Right-Hand	1	Frames/Covers	
151646W	Gasket, Freespool	1	Frames/Covers	
2312009	Seal, Top	1	Frames/Covers	
2312208	Gasket, Hose Seal	1	Frames/Covers	
252566	Seal Kit, Directional Valve (P/N 2311592)	1	Control Manifold Assy	
2312111	Seal Kit, Cartridge Valve (P/N 2312073)	2	Control Manifold Assy	
2312112	Seal Kit, Shuttle Valve (P/N 2312074)	1	Control Manifold Assy	
243815	Seal Kit, Cavity Plug (P/N 258473)	1	CBR Manifold Assy	
251170	Seal Kit, Cavity Plug (P/N 256462)	2	CBR Manifold Assy	

Motor, Reducer & Brake Assembly Rebuild Kit, P/N: 2314659				
Applies to: All				
Service Interval: Every 5,000 Hours				
Allied P/N	Description	Qty in Kit	See Parts Manual Page	Order Qty
2314659	Rebuild Kit, Motor, Reducer & Brake Assy			
203564	. O-Ring	2	Motor Shaft Group	
237349	. O-Ring	1	Motor Shaft Assembly	
313022W	. Adhesive	1	Motor Shaft Assembly	
230064W	. Adhesive	1	Motor Shaft Assembly	
2312302	. Kit, O-Ring	1	Brake, Dry Disc	
2313890	. O-Ring	1	Hydraulic Motor	
2313891	. Kit, Shaft Seal	1	Hydraulic Motor	

Intermediate/Drum Shaft, and Brake Assembly Rebuild Kit, P/N: 2314660
Applies to: All
Service Interval: Every 10,000 hours

Allied P/N	Description	Qty in Kit	See Parts Manual Page	Order Qty
2314660	Rebuild Kit, Intermed./Drum Shaft, & Brake Assy			
2312303	. Repair Kit, Bearing	1	Brake, Dry Disc	
250850	. Repair Kit, Spring	1	Brake, Dry Disc	
250847	. Repair Kit, Lining	1	Brake, Dry Disc	
2300668W	. Cup, Bearing	1	Motor Shaft Group	
2300669W	. Cone, Bearing	1	Motor Shaft Group	
30059W	. Cup, Bearing	1	Shaft, Intermediate Gear	
30080W	. Cone, Bearing	1	Shaft, Intermediate Gear	
159940W	. O-Ring	1	Shaft, Intermediate Gear	
2302311	. Cone, Bearing	2	Shaft, Intermediate Gear	
30059W	. Cup, Bearing	2	Shaft, Intermediate Gear	
15862W	. O-Ring	2	Shaft, Intermediate Gear	
212380	. O-Ring	1	Shaft, Intermediate Gear	
230406W	. Bearing, Roller	2	Shaft, Drum	
15881W	. O-Ring	1	Shaft, Drum	
44547W	. Seal, Oil	1	Shaft, Drum	
133927W	. Ring, Piston Seal	1	Shaft, Drum	
90263W	. O-Ring	1	Shaft, Drum	

Wire Rope Assemblies
Order as Required
Applies to: All

Allied P/N	Description	Length	Will Fill Drum To:	Order Qty
WR6-275L	Wire Rope Assy, 3/4"	275 FT (84 M)	2/3 Capacity (Recommended)	
WR6-413L	Wire Rope Assy, 3/4"	413 FT (126 M)	Full Capacity	
WR7-198L	Wire Rope Assy, 7/8"	198 FT (60 M)	2/3 Capacity (Recommended)	
WR7-297L	Wire Rope Assy, 7/8"	297 FT (91 M)	Full Capacity	
WR8-154L	Wire Rope Assy, 1"	154 FT (47 M)	2/3 Capacity (Recommended)	
WR8-230L	Wire Rope Assy, 1"	230 FT (70 M)	Full Capacity	
YS6-275LWS	Wire Rope Assy, 3/4"	275 FT (84 M)	2/3 Capacity (Recommended)	
YS6-413LWS	Wire Rope Assy, 3/4"	413 FT (126 M)	Full Capacity	
YS7-198LWS	Wire Rope Assy, 7/8"	198 FT (60 M)	2/3 Capacity (Recommended)	
YS7-297LWS	Wire Rope Assy, 7/8"	297 FT (91 M)	Full Capacity	
YS8-154LWS	Wire Rope Assy, 1"	154 FT (47 M)	2/3 Capacity (Recommended)	
YS8-230LWS	Wire Rope Assy, 1"	230 FT (70 M)	Full Capacity	

Spare Parts					Order as Required
Applies to: Shantui DH17 (H6HT6B**U47)					
Allied P/N	Description	Qty on Winch	Relevant for Installation	See Parts Manual Page	Order Qty
2316469 *a 2316072 *b	Motor, Hydraulic	1	Shantui DH17 (H6HT6B**U47)	Motor Shaft Group	
2312155	Assembly, Brake	1	All	Motor Shaft Assembly	
21420W	Plug, Breather	1	All	Frame/Covers	
2300962W	Cap, Breather	1	All	Frame/Covers	
95959W	Pin, Drawbar	1	All	Frame/Covers	
2303221W	Pin, Retaining	1	All	Frame/Covers	
2312099	Nut, Blind	2	All	Shaft, Drum	
2301783W	Keeper, Ferrule	1	All	Shaft, Drum	
328715W	Disc, Friction	7	All	Clutch Assembly	
283434W	Assembly, Gear	1	All	Shaft, Intermediate Gear	
2570W	Bushing	6	All	Fairlead, 3-Roller	
2570W	Bushing	8	All	Fairlead, 4-Roller	

*a First used with S/N1714

*b Last used with S/N1713

Operator Controls Components				Order as Required
Applies to: All				
Allied P/N	Description	Qty on Winch	Order Qty	
2310013	Assembly, Switch (Yellow LED)	1		
2310504	Assembly, Switch (Red LED)	1		
2310506	Assembly, Switch (Red LED), Momentary	1		
2311072	Assembly, Switch (Green LED)	1		

Tool Kits

Order these tool kits as required for installation, maintenance and service of your winch.

Allied P/N	Description	Order Qty
588466	Socket Set, 3/8DR 3/8" to 7/8" STD/Deep, 22 PC	
588467	Socket Set, 1/2DR 3/8" to 1-1/4" STD/Deep, 30 PC	
588468	Socket Set, 3/4DR 7/8" to 2-3/8" STD, 29 PC	
588469	Wrench Set, 5/16" to 2-1/2", 31 PC	
588527	Hex Key Sets, .025" to 5/8", 18 PC	
588530	Socket Sets, 3/8DR 6mm-19mm 12 Point	
588529	Socket Sets, 1/2DR 10mm-26mm 12 Point	
588528	Wrench Sets, 7mm-24mm, 18 PC	
588526	Hex Key Sets, .07mm-17mm, 15 PC	

Diagnostic Tools

Order as Required

Order these tools as required for maintenance and service of your winch.

Allied P/N	Description	Order Qty
906601	0 to 8700 PSI Digital Pressure Gauge W/Female QD Connector	
69782	72" Hose Assembly W/QD Connectors Both Ends	
70381	144" Hose Assembly W/QD Connectors Both Ends	
69778	Multi-Meter, 12 Function	

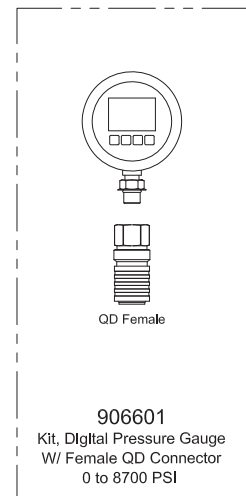
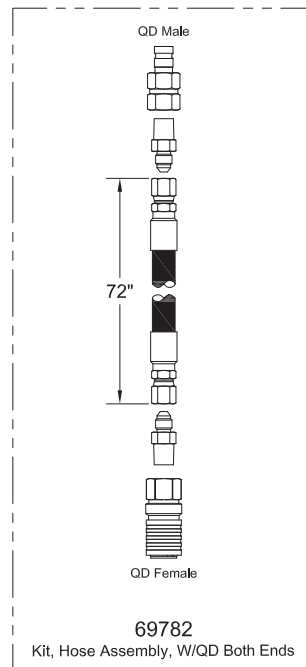
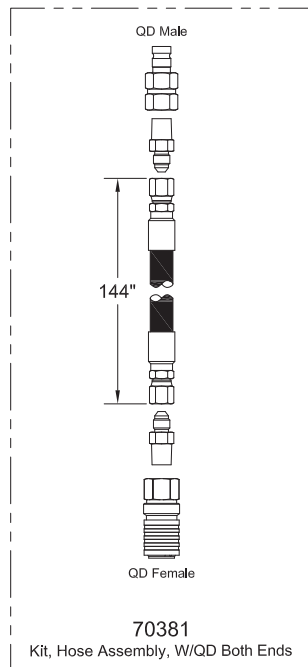
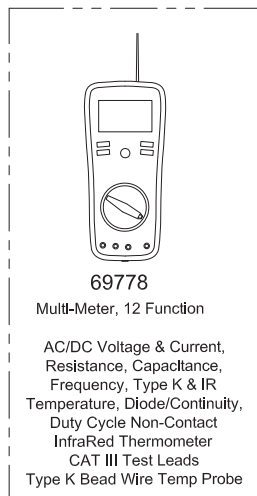

Section 7
Numerical Index

Part No.	Page	Item No.	Part No.	Page	Item No.	Part No.	Page	Item No.
203564	17	13	2311880	22	10	2312442	22	6
203564	44	1	2311894	27	1	2312486	13	3.14
211564	31	2.27	2311903	22	11	2312486	28	23
212380	27	5	2311903	23		2312487	17	5
212380	48	12	2311904	23	1	2312487	26	20.6
227949	32	7	2311905	22	21	2312488	17	3
229345	32	6	2311906	23	6	2312488	27	20
229383	31	2.1	2311907	23	2	2312554	18	3
229389	31	2.9	2311917	17	14	2312554	18	3
231439	22	3	2311918	17	15	2312580	13	2.3
231439	31	2.22	2312006	13	13.6	2312580	36	18
231465	31	2.15	2312018	17	9	2312580	37	16
231822	31	2.23	2312029	23	3	2312580	38	18
232984	31	2.24	2312036	17	7	2312580	39	16
235387	31	2.11	2312039	22	4	2312628	31	2.3
235387	32	5	2312041	18	1.4	2312849	13	18.2
236855	31	2.17	2312041	18	1.4	2312850	13	18.1
237349	18	1.5	2312045	13	3.2	2312928	18	4
237349	18	1.5	2312046	13	13.5	2312928	18	4
237349	44	2	2312048	13	3.1	2312940	32	1
243815	32		2312059	17	11	2312941	31	2.1
250847	48	3	2312060	17	12	2312941	32	
250850	48	2	2312061	17	10	2312977	22	21
252566	33		2312064	28	20	2313026	22	
259258	32		2312068	32	2	2313639	31	2.36
592255	31	2.5	2312073	33	3	2313730	28	26
2303036	27	8	2312074	33	4	2313890	18	
2310093	28	3	2312099	28	25	2313890	18	
2310181	32	4	2312111	33		2313890	44	6
2310726	35	17	2312112	33		2313891	18	
2310891	28	18	2312117	13	13.2	2313891	18	
2311251	23	9	2312119	13	13.4	2313891	44	7
2311592	33	2	2312155	25		2313948	31	2.6
2311655	22	7	2312168	35	18	2313984	33	
2311683	22	5	2312208	13	5.2	2314097	37	4
2311684	22	15	2312212	31	2.33	2314097	39	4
2311687	22	20	2312269	27	14	2314106	33	
2311770	31	2.2	2312280	27	13	2314411	26	21.1
2311770	33		2312302	44	5	2314659	44	
2311771	33	1	2312303	48	1	2314660	48	
2311819	17		2312350	31	2.32	2315544	37	1.1
2311855	22	1	2312351	31	2.34	2315544	39	1.1
2311856	22	2	2312353	31	2.31	2315544	39	8.1
2311857	17	1	2312437	36	17	2315545	37	1
2311869	22	18	2312437	38	17	2315545	39	1

Part No.	Page	Item No.	Part No.	Page	Item No.	Part No.	Page	Item No.
2315546	37	2	15881W	48	14	2301706W	35	20
2315546	39	2	159940W	27	10	2301706W	36	4
2315548	37		159940W	48	8	2301706W	37	3
2315549	39		16001W	35	9	2301706W	38	4
2315555	37	7	16001W	36	6	2301706W	39	3
2315555	39	7	16001W	37	5	2301718W	36	8
2316071	18		16001W	38	6	2301718W	38	8
2316071	18	1.1	16001W	39	5	2301721W	36	11
2316071	18	1.1	16829W	28	16	2301721W	37	9
2316072	18	2	172808W	28	7	2301721W	38	11
2316108	31	2.3	172810W	28	24	2301721W	39	9
2316109	31	2.4	173607W	37	15	2301722W	36	3
2316162	13	3.6	173607W	39	15	2301722W	38	3
2316468	18		175646W	28	14	2301724W	37	8.1
2316469	18	2	175647W	28	13	2301726W	36	9
2316491	17	7	175648W	28	12	2301726W	37	8
133927W	28	10	177192W	18	1.8	2301726W	38	9
133927W	48	16	177192W	18	1.8	2301726W	39	8
137153W	22	16	18668W	37	12	2301727W	36	1
137155W	22	17	18668W	38	14	2301727W	38	1
141671W	28	19	18668W	39	12	2301732W	38	
141674W	28	1	18669W	36	14	2301748W	35	
149541W	26	20.8	21420W	13	3.11	2301749W	35	1
149542W	26	20.9	221336W	35	12	2301783W	28	15
149543W	26	20.1	221577W	28	4	2301907W	35	2
151589W	13	3.9	221716W	18	1.3	2301910W	35	7
15158W	28	5	221716W	18	1.3	2301919W	35	14
151646W	13	3.1	221717W	27	16	2301920W	35	13
15166W	36	15	221767W	18	1.7	2301924W	35	19
15166W	37	13	221767W	18	1.7	2301925W	35	15
15166W	38	15	221771W	28	17	2301961W	37	1.2
15166W	39	13	221777W	18	1.9	2301961W	37	8.2
15176W	31	2.14	221777W	18	1.9	2301961W	39	1.2
15178W	31	2.26	222713W	23	10	2301961W	39	8.2
15272W	13	2.4	226374W	36	12	2302120W	35	11
15272W	36	16	226374W	37	10	2302311W	27	17
15272W	37	14	226374W	38	12	2302311W	48	9
15272W	38	16	226374W	39	10	2302624W	27	9
15272W	39	14	230064W	44	4	2302625W	27	11
15290W	13	2.5	2300668W	17	16	2303221W	13	2.2
15315W	13	2.6	2300668W	48	4	2303992W	22	13
15319W	13	3.13	2300669W	17	17	230406W	48	13
15862W	27	4	2300669W	48	5	230407W	22	19
15862W	48	11	2300962W	13	3.12	2304803W	27	15
15881W	28	8	2301706W	35	5	2305096W	27	7

Part No.	Page	Item No.	Part No.	Page	Item No.	Part No.	Page	Item No.
2305097W	27	2	296422W	27	21	95973W	26	20.2
2305099W	27	3	296422W	28	22	95977W	28	21
2305130W	17	20	30059W	26	20.4	95978W	28	6
2305956W	27	12	30059W	27	18	96024W	26	21.1
2307438W	32	3	30059W	48	6	R12104	31	2.35
2307625W	31	2.28	30059W	48	10	R13801826	18	1.6
2307904W	31	2.8	30080W	26	20.5	R13801826	18	1.6
239147W	22	12	30080W	48	7	R13811617	22	14
2570W	36	2	313022W	44	3	R14040	31	2.29
2570W	36	10	328715W	23	4	R833103	31	2.21
2570W	37	1.3	331767W	35	4	R833218	31	2.7
2570W	37	8.3	33394W	36	5	R833251	18	1.1
2570W	38	2	33394W	38	5	R833251	18	1.1
2570W	38	10	35135W	35	3	R833251	31	2.18
2570W	39	1.3	35135W	35	8	R833253	31	2.19
2570W	39	8.3	398817W	35	6	R833260	31	2.2
261542W	23	5	398817W	35	21	R833400	31	2.16
280262W	26	20.3	398817W	36	7	R834100	31	2.25
2817W	35	16	398817W	37	6	WR6-275L	40	
2821W	35	10	398817W	38	7	WR6-413L	40	
283432W	27	8A	398817W	39	6	WR7-198L	40	
283434W	27	8	44547W	28	9	WR7-297L	40	
292656W	17	8	44547W	48	15	WR8-154L	40	
293628W	23	8	53559W	28	2	WR8-230L	40	
293645W	13	3.15	86585W	22	8	Y09C-M1025	31	2.12
293645W	13	13.1	87287W	22	9	Y17C-1232	18	1.2
293645W	17	6	90263W	28	11	Y17C-1232	18	1.2
293647W	17	19	90263W	48	17	Y433070.45	28	27
296420W	23	7	93878W	36	13	YS6-275LWS	40	
296420W	31	2.13	93878W	37	11	YS6-413LWS	40	
296422W	13	3.16	93878W	38	13	YS7-198LWS	40	
296422W	13	13.8	93878W	39	11	YS7-297LWS	40	
296422W	17	4	95959W	13	2.1	YS8-154LWS	40	
296422W	26	20.7	95972W	26	20.1	YS8-230LWS	40	



To find a dealer in your area,
Call: (503) 625-2560,
Fax: (503) 625-7269, or
Email: marketing@alliedsystems.com, or
Visit our website: <http://www.alliedsystems.com>

599039W-SHANTUI 3/2019 Printed in U.S.A.

