

Service Manual



H5C

Hydraulic Winch

Applicable to winches with serial numbers H5C***1226*** and later.

A Product of

Allied Systems
COMPANY

Sherwood, OR USA

Please check the Allied Systems website
regularly for updates to this manual.
www.alliedsystems.com

Safety Precautions

**Read, understand and observe the Safety Summary
on pages i through iii
to prevent injury to personnel and damage to equipment.**

Winch serial number _____

Date put into service _____

**NOTE: This publication may be translated to different languages for sole purpose
of easy reference in non-English speaking locations.
Should there be differences in interpretations to the text,
please refer to the English language edition published by Allied Systems Company
as the controlling document.**

Safety Summary

General Safety Notices

The following pages contain general safety warnings which supplement specific warnings and cautions appearing elsewhere in this manual. All electrical and hydraulic equipment is dangerous. You must thoroughly review and understand the Safety Summary before attempting to operate, troubleshoot or service this winch.

The following symbols and terms are used to emphasize safety precautions and notices in this manual:



The “DANGER” symbol indicates a hazardous situation which, if not avoided, will result in serious injury or death. Carefully read the message that follows to prevent serious injury or death.



The “WARNING” symbol appears wherever incorrect operating procedures or practices could cause serious injury or death. Carefully read the message that follows to prevent serious injury or death.



The “CAUTION” symbol appears where a hazardous situation which, if not avoided, could result in minor to moderate injury and equipment damage.



This signal word alerts to a situation that is not related to personal injury but may cause equipment damage.

NOTE: ...

The term “NOTE” highlights operating procedures or practices that may improve equipment reliability and/or personnel performance.

NOTE: All possible safety hazards cannot be foreseen so as to be included in this manual. Therefore, you must always be alert to potential hazards that could endanger personnel and/or damage the equipment.

Safety Regulations

Each country has its own safety legislation. It is in the operator’s own interest to be conversant with these regulations and to comply with them in full. This also applies to local bylaws and regulations in force on a particular worksite.

Should the recommendations in this manual deviate from those in the user’ country, the national regulations should be followed.

Operation, Inspection, and Maintenance Warnings

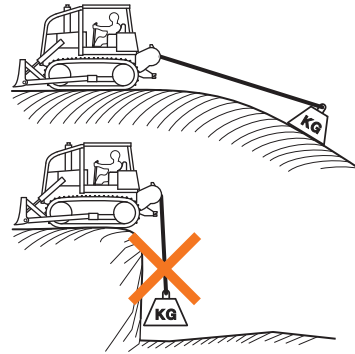


Obey the following cautions and warnings before using your winch to avoid equipment damage, personal injury or death.

- Do not operate the winch unless your are authorized and trained to do so.
- Do not operate the winch unless the vehicle is equipped with a screen to protect the operator if the wire rope breaks.
- Read, understand, and follow the operating, inspection, and maintenance instructions in this manual.
- Do not use the control levers for hand holds when entering or leaving the vehicle.
- Do not permit other people near the control area when you inspect or repair a machine.
- Never inspect, repair, or perform maintenance on a machine that is in motion.

- Inspect the winch before each use:
 - » Make sure that the controls and instruments operate correctly.
 - » Report the need for repairs immediately.
 - » Do not work with a damaged or worn wire rope.
 - » Do not use a winch that needs repairs.
 - » If the wire rope and ferrule must be removed from the drum, make sure the end of the wire rope and ferrule are controlled when the ferrule is released. The end of the wire rope can suddenly move from the drum like a compressed spring when the ferrule is released, and cause an injury.
- Stay in the operator's seat when operating the winch.
- Do not stand on the vehicle when operating the winch.
- Avoid winch operation near people or other machines.
- Never stand nor permit others to stand in the bight (loop) of a wire rope.
- Do not stand nor permit others to be near the winch or wire rope when there is tension on the wire rope.
- Observe jobsite rules.
- Be in complete control at all times.
- Do not use the control levers as hangers for clothes, water bags, grease guns, lunch pails, etc.
- Do not leave the vehicle when the winch wire rope is under tension.
- Do not permit riders on the vehicle or load.
- Do not use the winch as an anchor for a double or two-part line.
- Do not pull the hook through the throat or over the drum, which will cause damage.
- When the winch is not in use, make sure the control lever is in **BRAKE-ON** position and the winch brake is applied.

- Do not use winch as a hoist. Tractor and skidder mounted winches are designed for towing.



- Always inspect wire rope, tail chain and other rigging components for wear, damage, broken strands or abuse before use.
- Never use wire rope, tail chain or other rigging that is worn-out, damaged or abused.
- Never overload wire rope, tail chain or rigging.
- Wire rope and tail chain will fail if worn-out, overloaded, misused, damaged, improperly maintained or abused. Wire rope or tail chain failure may cause serious injury or death!



- Do not terminate wire rope to tail chain by the use of a knot.
- Do not handle wire rope if the hook end is not free. A load could break away, suddenly tensioning the wire rope, resulting in serious injury or death.
- Stay clear of wire rope entry areas (fairlead or arch rollers, winch drum etc).
- Make sure ground personnel are in plain view of the operator, and at a distance of at least 1½ times the working length of the wire rope.

- Make sure that any hand signals used by ground personnel are clearly defined and understood by everyone involved.
- Do not attempt to “jerk” or “shock” a load free. Doing so can cause loads in excess of the rated capacity of the wire rope, winch, or mounting hardware.
- Replace any parts only with genuine Allied Winch parts. Refer to Parts Manual 599048W.
- Maintain a **minimum of three (3) complete wraps of wire rope** on the drum for normal operation. It may help to paint the last five wraps of wire rope a contrasting color, to serve as a visual indicator.
- Do not handle wire rope with bare hands. Wear leather gloves at all times.
- Align the tractor with the load to prevent side loading the winch, and to maintain even spooling of the wire rope.
- If applying tension to the wire rope manually during spooling:
 - » ensure that the operator is winching in slowly,
 - » keep your hands and clothing well clear of any rollers or the winch drum,
 - » do not maintain tension by letting the wire rope to slip through your hands,
 - » use a hand-over-hand technique to maintain tension.
- Be aware of the ground conditions, and make sure the ground and tractor are stable enough to pull the intended load.
- Do not attempt to pull loads in excess of the rated capacity of the winch.
- Keep yourself informed of any applicable codes, regulations and standards for the job.
- Your winch may have temperature shut-off system for protection of tractor and winch. Manual override of high temperature shut-off will cause damage to tractor and winch.
- This winch is neither intended, designed, nor rated for any application involved in the lifting or moving of personnel.
- Use only the lubricants listed in the Recommended Oil List. See pages 1-4 and 1-5.
- Do not weld on any part of the winch. Contact Allied Systems if weld repairs are needed.
- The hydraulic system must be kept clean and free of contamination at all times.
- Be aware of the hazards of pressurized hydraulics:
 - » Wear personal protective equipment, such as gloves and safety glasses, whenever servicing or checking a hydraulic system.
 - » Assume that all hydraulic hoses and components are pressurized. Relieve all hydraulic pressure before disconnecting any hydraulic line.
 - » Never try to stop or check for a hydraulic leak with any part of your body; use a piece of cardboard to check for hydraulic leaks.
 - » Small hydraulic hose leaks are extremely dangerous, and can inject hydraulic oil under the skin, even through gloves.
 - » Infection and gangrene are possible when hydraulic oil penetrates the skin. See a doctor immediately to prevent loss of limb or death.



Ordering Parts:

When ordering replacement parts, give the unit serial number, part number, name of part and quantity required.

For any further information on parts, service or ordering, consult your local winch dealer, or contact Allied Systems Company:

Allied Systems Company
21433 SW Oregon Street
Sherwood, OR 97140 USA

Phone: 503-625-2560
Fax: 503-625-5132
E-Mail: parts@alliedsystems.com

Also see our website, www.alliedsystems.com, where the most current copy of this manual is always available.

Contents

Safety Summary	i	Service.....	3-1
General	1-1	General	3-1
Introduction	1-1	Maintenance	3-1
Description	1-1	Maintenance Points.....	3-1
Unit Identification.....	1-2	Maintenance Schedule.....	3-1
Serial Number Codes.....	1-3	Checks Before Operation	3-2
Nameplate.....	1-3	Checks During Operation.....	3-2
Specifications	1-4	FREESPOOL Drag Adjustment.....	3-2
Drum Wire Rope Capacities	1-4	Hydraulic System Pressure Checks	3-2
Hydraulic Specifications	1-4	Preparation.....	3-2
Oil Specifications.....	1-4	Pilot Supply Pressure Check	3-4
Oil Capacity.....	1-4	 	
Maintenance Decal	1-5	Installations without Optional DRAG-BRAKE:	
Torque Specifications.....	1-5	Motor Supply Pressure Check.....	3-5
Gear Train	1-6	Brake Pressure Check.....	3-6
FREESPOOL Operation	1-7	Brake Valve Pressure Check & Adjustment	3-7
Operation and Control	1-8	FREESPOOL Pressure Check	3-8
Brake	1-10	LINE-IN Pressure Check.....	3-9
Motor	1-11	LINE-OUT Pressure Check	3-10
Counterbalance Relief Manifold.....	1-12	 	
Control Manifold (without DRAG-BRAKE)	1-13	Installations with Optional DRAG-BRAKE:	
Control Manifold (with DRAG-BRAKE)	1-13	Motor Supply Pressure Check.....	3-11
 		Brake Pressure Check.....	3-12
Sequence of Operation - <u>K371 & L39</u>		Brake Valve Pressure Check & Adjustment	3-13
BRAKE-ON	1-15	FREESPOOL Pressure Check	3-14
LINE-IN	1-17	LINE-IN Pressure Check.....	3-15
LINE-OUT	1-19	LINE-OUT Pressure Check	3-16
FREESPOOL	1-21	DRAG-BRAKE Pressure Check	3-17
Sequence of Operation - C805, R371, R42		 	
BRAKE-ON	1-23	Repairs	4-1
LINE-IN	1-25	General	4-1
LINE-OUT	1-27	Winch Removal.....	4-1
FREESPOOL	1-29	Winch Disassembly	4-1
Sequence of Operation - Y46F		Drum and Drum Shaft	4-2
BRAKE-ON	1-31	Intermediate and FREESPOOL Shaft.....	4-3
LINE-IN	1-33	Motor Removal	
LINE-OUT	1-35	Winches without optional DRAG-BRAKE.....	4-4
FREESPOOL	1-37	Winches with optional DRAG-BRAKE	4-5
DRAG-BRAKE	1-39	Motor Disassembly.....	4-6
 		Brake Removal.....	4-10
Schematics	1-41	Brake Disassembly.....	4-14
 		Drag Brake Disassembly.....	4-15
Troubleshooting.....	2-1	Winch Assembly	4-16
General.....	2-1	Visual Inspection	4-16
Mechanical/Hydraulic Troubleshooting Charts.....	2-1	Drag Brake Assembly	4-18
		Brake Assembly.....	4-19
		Brake Installation.....	4-20
		Motor Assembly	4-24
		Motor Installation	
		Winches without optional DRAG-BRAKE....	4-28
		Winches with optional DRAG-BRAKE	4-29
		Winch Installation	4-30

General

Introduction

This service manual is for the H5C hydraulic winch. The following information is included in this manual:

Section 1. General includes operation descriptions of systems and components as an aid for troubleshooting and repair.

Section 2. Troubleshooting lists common problems and the possible causes and corrections.

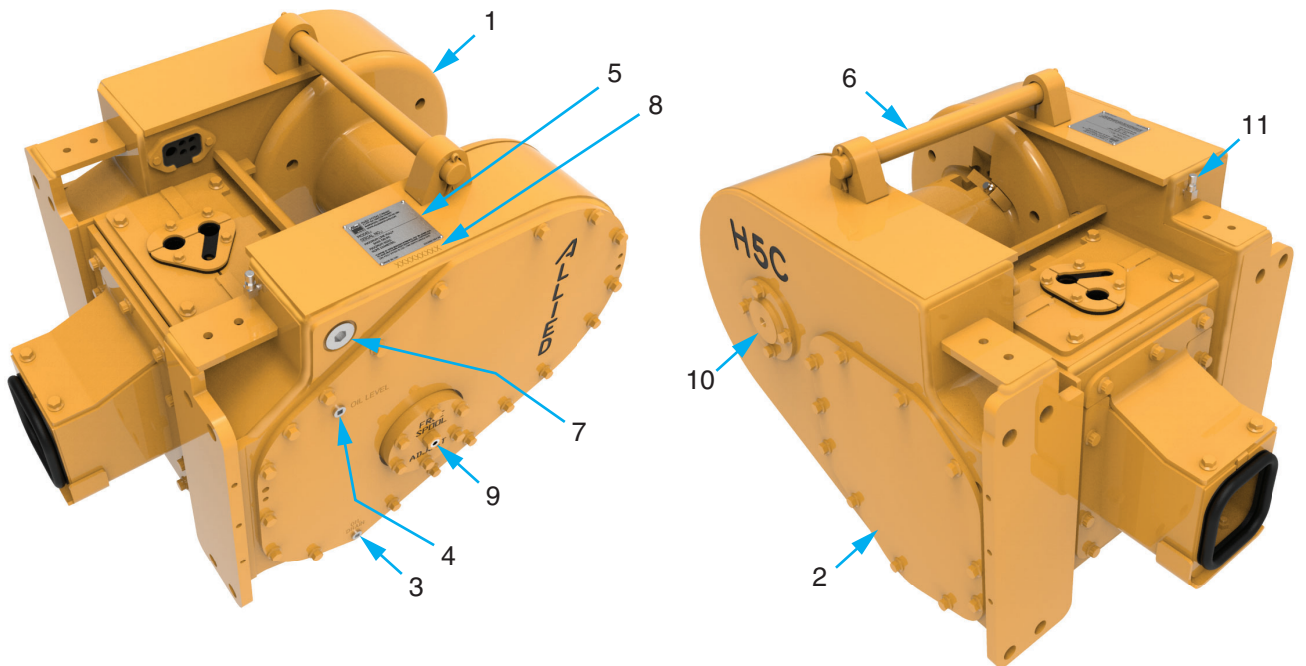
Section 3. Maintenance provides a guide for periodic maintenance, checks and adjustments.

Section 4. Repairs describes the removal, disassembly and assembly of the winch.

Description

The H5C Winch is a Power Forward (**LINE-IN**) and Power Reverse (**LINE-OUT**) winch. The winch is powered by an internal hydraulic motor connected to the tractor hydraulic system. Oil flow and pressure are converted to rotational energy by the winch motor. Motor torque is transmitted through a holding brake and two gear reductions to the drum. Hydraulic oil is supplied by the tractor mounted auxiliary pump circuit or designated winch pump. The winch utilizes oil, cooling, and sometimes filtration provided by the tractor circuit. Flow to the winch is controlled by a control lever and electrical switches located at the tractor's control station.

The H5C winch has a maximum rated line pull capacity of 222,400 N (50,000 lbf) when there is one layer or less of wire rope on the drum. When there is more than one layer of wire rope on the drum, the maximum rated line pull is reduced.

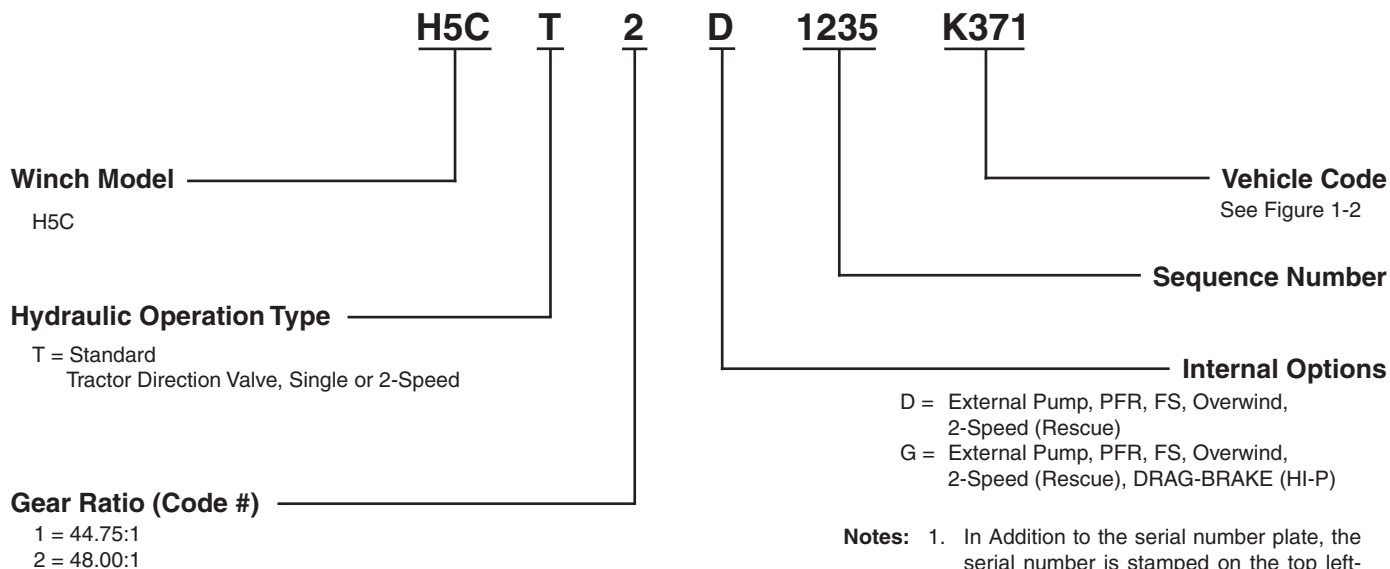


- | | |
|--|---|
| 1. Drum | 7. Fill Plug |
| 2. Access Cover for Motor and Hydraulics | 8. Serial Number Stamp |
| 3. Plug to Drain Oil | 9. Bearing Retainer for Intermediate Shaft & Freespool Drag |
| 4. Plug to Check Oil Level | 10. Right Side Drum Shaft |
| 5. Serial Number Plate | 11. Breather |
| 6. Tie Bar | |

Figure 1-1 H5C Winch

Unit Identification

Allied Winch S/N Nameplate Data For Tractor Mountings



- Notes:**
1. In Addition to the serial number plate, the serial number is stamped on the top left-hand side of the frame. (See Figure 1-1 on page 1-1.)
 2. Circled numbers in Figure 1-2 indicate possible gear ratio.

Tractor Make Model and Starting Tractor Serial Number Where Applicable

C O D E	C Caterpillar	K Komatsu	L Liebherr	R Case	Y TCi
39			PR716 ②		
42				1650M ②	
46F					920 ②
371		D51-24 ②		1150M ②	
805	D6K2 T4f ①				

Figure 1-2 Tractor Identification Codes and Available Gear Ratios for H5C Winch

Serial Number Codes

The serial number codes are described on page 1-2 of this manual. The nameplate with the serial number code is found on the top left hand side of the winch case. The serial number code is also stamped on the left hand side of the winch frame.

Nameplate

The rated capacity for the winch, as it is equipped, is shown on the nameplate. Each winch is shipped from the factory with a nameplate as shown in Figure 1-3. If the nameplate is missing, or the wire rope does not match the information on the nameplate, do not operate the winch until its capacity is known and a new nameplate is installed. Each winch must be operated within its rated capacity as shown on the nameplate.



Figure 1-3 Nameplate

Specifications

Drum Wire Rope Capacities (Drum: 9 Inch Diameter)

WIRE ROPE DIAMETER	Length (2/3 Drum Capacity*)	Length (Full Drum Capacity**)
16 mm (5/8 in)	85 m (279 ft.)	129 m (423 ft.)
19 mm (3/4 in)	60 m (197 ft.)	91 m (298 ft.)
22 mm (7/8 in)	43 m (142 ft.)	66 m (215 ft.)

Notes: * Recommended length to fill drum up to 2/3 capacity to leave room for uneven spooling.
 ** Length to fill drum to full capacity. Will have no room for uneven spooling. Not recommended.
 1. Wire Rope: IWRC 6 X 19, extra improved plow steel, with ferrule, tail chain and hook.
 2. Loosely or unevenly spooled wire rope will change capacities. Use flexible wire rope with independent wire rope center.
 3. Ferrule: Light (2-1/4" Long X 2" Diameter)

Figure 1-4 Drum Wire Rope Capacities

Hydraulic Specifications

Motor Hydraulic 2-Speed Vane Single Pilot
 Brake Dry multi-disc spring applied

Oil Specifications

The hydraulic winch motor and control system operate off of the tractor implement hydraulic system. The winch gear case is filled with hydraulic transmission oil and is separate from the tractor hydraulic system. Factory fill for the gear case is Exxon-Mobil 424. For proper operation, only oils shown in Figure 1-5 should be used in the winch gear case.

Oil Capacity

The oil capacity for H5C winch is approximately 17 quarts (16 liters).

Recommended Oils* - General Conditions			
Manufacturer	Oil Type	Ambient Temperature Range	
		°F	°C
ExxonMobil	Mobil Fluid 424 (Factory fill)	-13 to 104	-25 to 40
John Deere	Hy-Gard™	-13 to 122	-25 to 50
Chevron	1000 THF	-13 to 104	-25 to 40
Caterpillar	Multipurpose Tractor Oil (MTO)	-13 to 104	-25 to 40
Case	Hy-Tran Ultra	-20 to 122	-29 to 50

Recommended Oils* - Low Temperature Conditions			
Manufacturer	Oil Type	Ambient Temperature Range	
		°F	°C
ExxonMobil	Mobil Fluid LT	-40 to 86	-40 to 30
John Deere	Low Viscosity Hy-Gard	-40 to 86	-40 to 30
Chevron	THF W	-40 to 86	-40 to 30

* Note: Use of a non-recommended oil may void warranty.

** For winches using tractor-supplied hydraulics for winch operation, recommended oil is used only in the winch gear case.

Figure 1-5 Recommended Oils

Maintenance Decal

Hydraulic Winch Maintenance					
Recommended Winch Service Intervals					
Hours or **	Months **	Filter ***	Winch Gear Oil	Brake & Clutch	Major Overhaul
First 250	1	Change			
Every 500	3	Change			
Every 2,000	12		Change		
Every 5,000				* Inspect	
Every 10,000					* Evaluate
Lube rollers and check oil level and filter light weekly.					
* Evaluate = Service based on average winch use; - if used more than once a day, perform overhaul. - if used less than once a day, remove covers and check to determine need. * Inspect = disassemble and inspect for wear. ** Service winch using the tractor's hour meter or the length of time the winch is mounted to the tractor, whichever occurs first. *** Follow tractor schedule if using tractor filter.					
Recommended Gear Compartment Oil: Caterpillar -Multipurpose Tractor Oil (MTO) John Deere -Hy-Gard ExxonMobil -Mobil Fluid 424 (Factory Fill) Chevron -1000 THF					
 Consult service/operating manual for low temperature oils and other details. Tractor final drive oils may be used in winch.					
 2311329 Rev C					

Figure 1-6 Maintenance Decal

Torque Specifications

Hardware Size	TORQUE VALUES		
	ft-lbs.	N-m	kg-m
3/8-UNC Grade 8	33 - 35	45 - 47	4.6 - 4.8
1/2-UNC Grade 8	80 - 84	108 - 114	11.1 - 11.6
5/8-UNC Grade 8	160 - 168	217 - 228	22.1 - 23.2
3/4-UNF Grade 8	375 - 385	508 - 522	51.8 - 53.2
3/4-UNC Grade 8	285 - 300	386 - 407	39.4 - 41.5

Figure 1-7 Torque Specifications

Gear Train (See Fig. 1-8)

The tractor pump or designated winch pump drives the hydraulic motor with hydraulic oil supply. The amount of pressure in the motor is dependent on the size of the load. The motor shaft rotates to give **LINE-IN** or **LINE-OUT**. Return oil is directed back to the tractor reservoir in open loop systems and back to the pump in hydrostatic closed loop systems. The motor is attached to a spring applied multi-disc brake that holds the winch drum in a fixed position. When oil is supplied to the hydraulic motor, the brake is simultaneously released with pilot control pressure.

The hydraulic motor can operate at half displacement when the operator selects the **HI-SPEED** switch. At half displacement the gear train rotates at roughly twice the speed.

An intermediate gear assembly gives further gear reduction to increase torque at the winch drum. A spring-loaded dental clutch with splines engages the drum pinion gear and the intermediate gear. The operator can disengage the dental clutch with an electric switch to activate the **FREESPOOL** feature.

A drum gear engages the drum pinion gear and is connected to the drum adapter (which connects the drum to the drum gear). When power is applied to the gear train, the drum will rotate in the forward or reverse direction. The other side of the drum runs on roller bearings held by the drum shaft. The drum shaft is connected to the winch case.

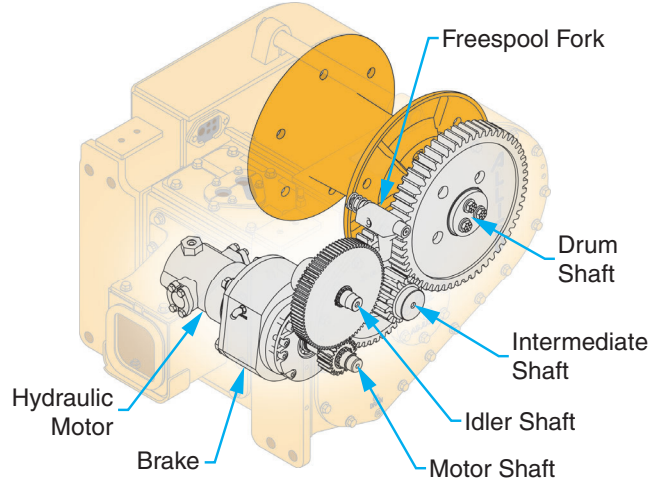


Figure 1-8 Gear Train

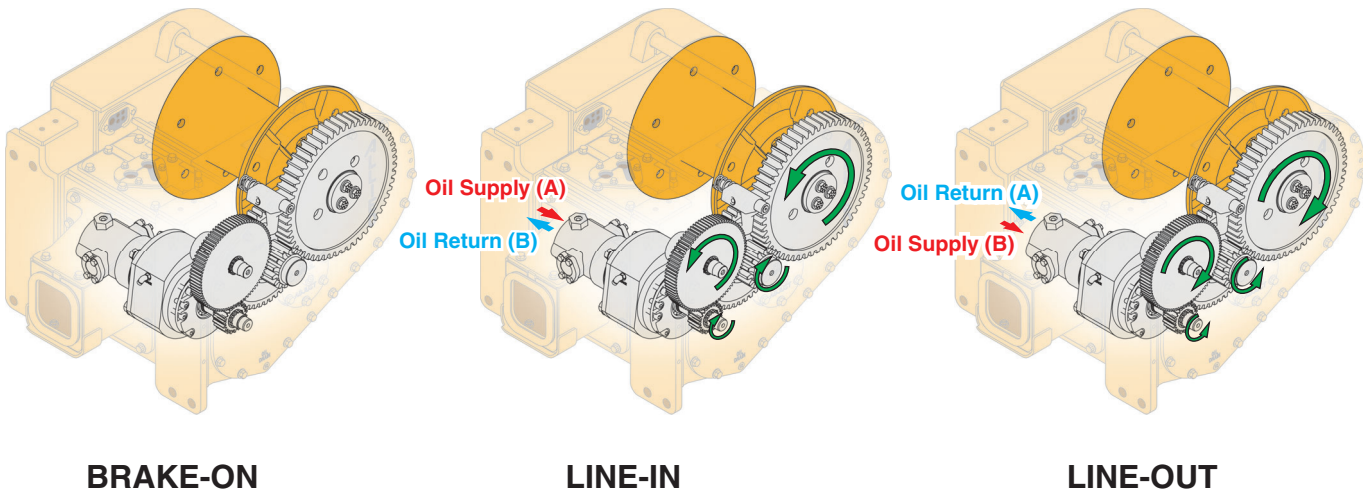


Figure 1-9 Rotation Torque Transfer

FREESPOOL Operation (See Fig. 1-10 & 1-11)

The **FREESPOOL** arrangement allows mechanical disengagement of the drum gear from the remainder of the gear train. When **FREESPOOL** is selected, a hydraulically-actuated sleeve disengages the dental clutch from the intermediate shaft. The drum is now disconnected from the brake and the winch cannot support a load.

WARNING

FREESPOOL should not be used if there is a load on the wire rope. An uncontrolled release of the load will occur. Loss of the load can result in equipment damage, personal injury or death.

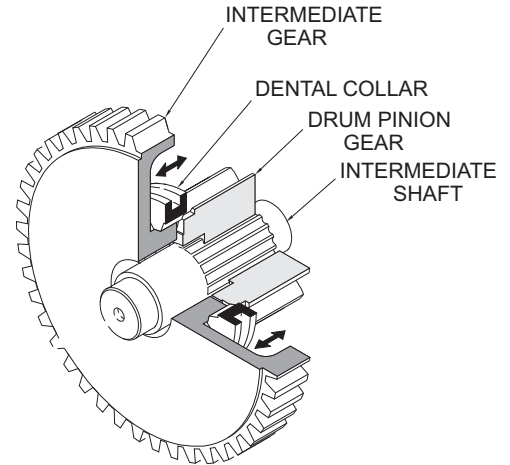


Figure 1-10 FREESPOOL Operation

The yellow indicator panel on the selector switch lights when the winch is in **FREESPOOL**.

NOTE: The dental clutch may not disengage if there is a load on the wire rope. Remove the load from the wire rope to activate the **FREESPOOL** function.

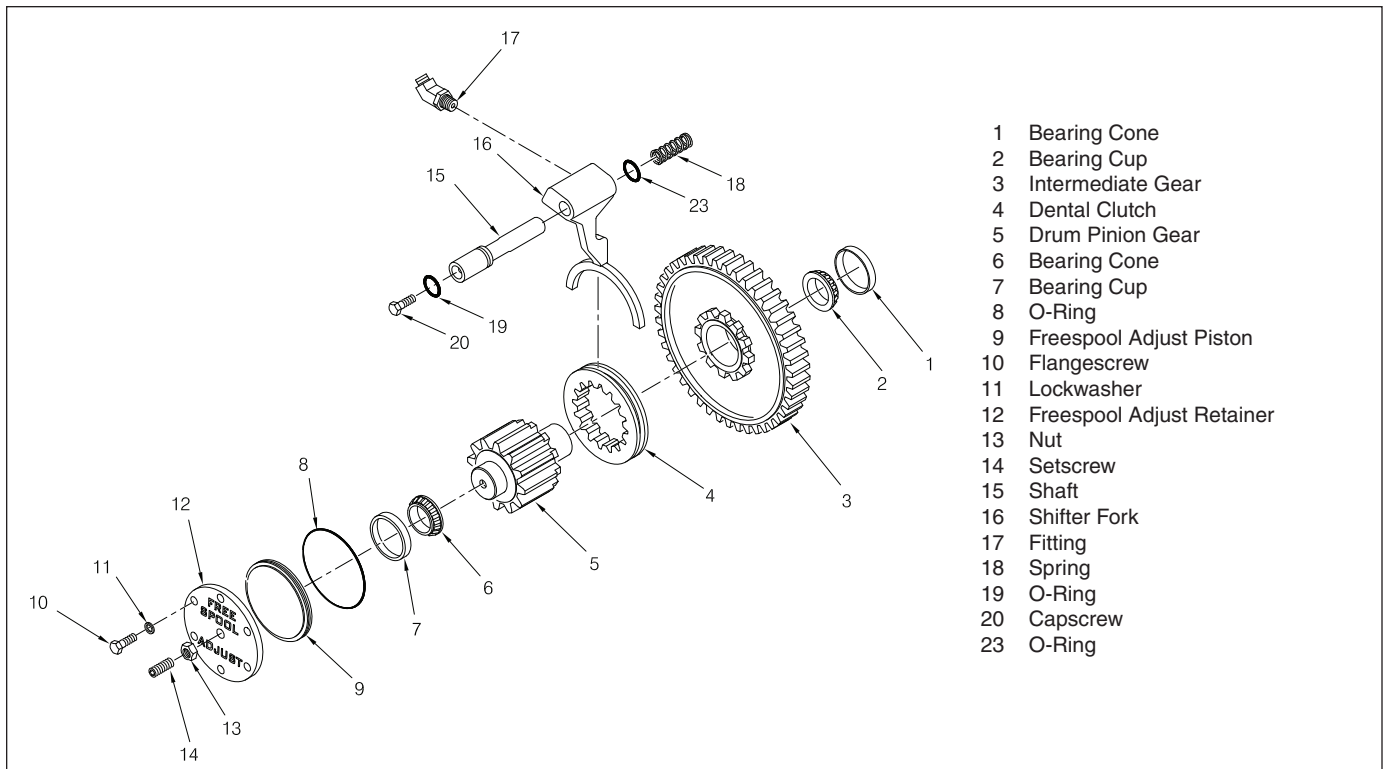


Figure 1-11 FREESPOOL Arrangement

Operation & Control (See Fig 1-12, 1-13)

The H5C winch is designed to operate with a pilot operated hydraulic system. Hydraulic tractor power supplies include variable displacement with load sensing control, fixed displacement, and variable displacement hydrostatic. When the tractor is running, the winch is ready to operate but no oil is flowing to the winch. Control (pilot) pressure is present at the winch.

The control lever and electrical switches are used to select the following operations (not all winches are equipped with all options):

BRAKE-ON (spring-centered position)

LINE-IN

LINE-OUT

FREESPOOL

HI-SPEED (either **LINE-IN** or **LINE-OUT**) (optional)

DRAG-BRAKE (optional)

The tractor must be running and the auxiliary hydraulic function switch, if equipped, must be on. **LINE-IN**, **LINE-OUT** and **BRAKE-ON** are controlled by a control lever.

When the control lever is in the **BRAKE-ON** or centered position, the holding brake is automatically applied. Pushing the lever away from the operator releases the brake and reels cable off the drum (**LINE-OUT**). Pulling the lever towards the operator releases the brake and reels wire rope onto the drum (**LINE-IN**). Releasing the lever causes it to return to the **BRAKE-ON** position, which stops the drum rotation and applies the holding brake. By moving the lever a small amount, slow wire rope movement is achieved for inching control. Line speed increases proportionally as the lever is moved farther.

The switch panel may contain three rocker switches that control **FREESPOOL**, **HI-SPEED** and **DRAG-BRAKE**. The tractor must be running to supply hydraulic power to operate these functions. The switch light illuminates when the switch is on.

The **FREESPOOL** switch has a lock to prevent inadvertent actuation. The slide lock must be released before the switch can be turned on.



WARNING

Before operating the winch in LINE-IN or LINE-OUT mode, ensure the FREESPOOL and DRAG-BRAKE lights are not illuminated. Doing so may result in loss of load.

HI-SPEED is selected with a dual-action momentary switch. A green light in the speed selector switch indicates **HI-SPEED** operation. For heavy loads or when better control is desired, the winch should be operated in low speed. For light loads and faster wire rope speed, operate the winch in **HI-SPEED** mode.

When the **DRAG-BRAKE** (optional) switch is selected, **FREESPOOL** is engaged, and a drag brake is engaged on the drum shaft, allowing the tractor to move slowly away from a towed load while keeping the wire rope taut. The tractor must be operated at low speed or the load may still be dragged.

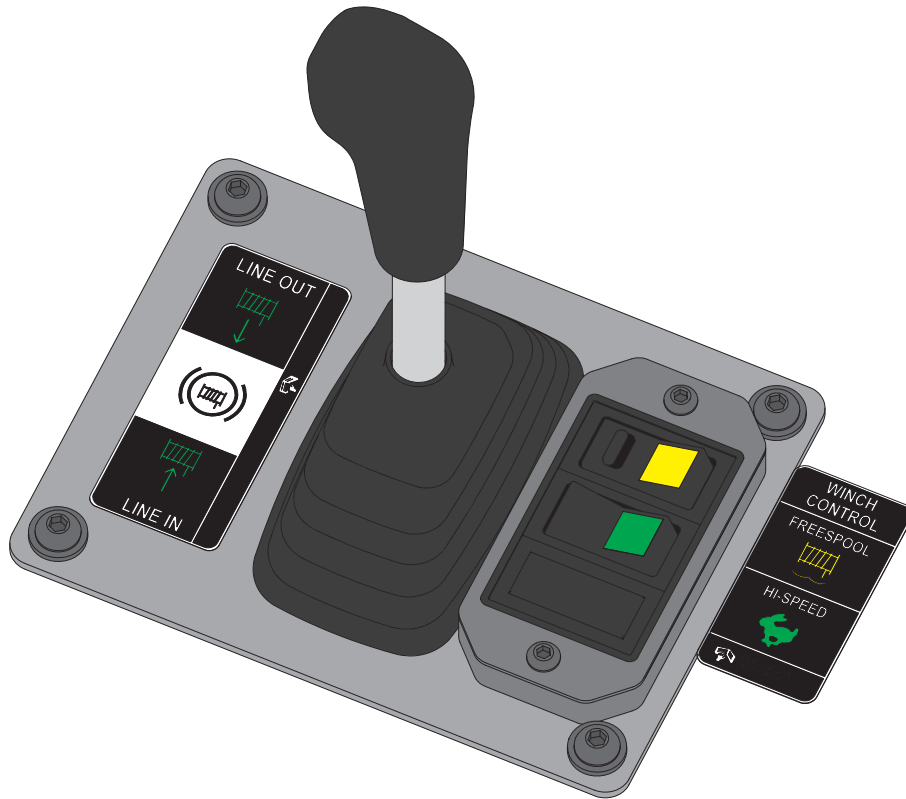


Figure 1-12 Winch Controls (Installation on Komatsu D51-24 shown. Your controls may vary.)

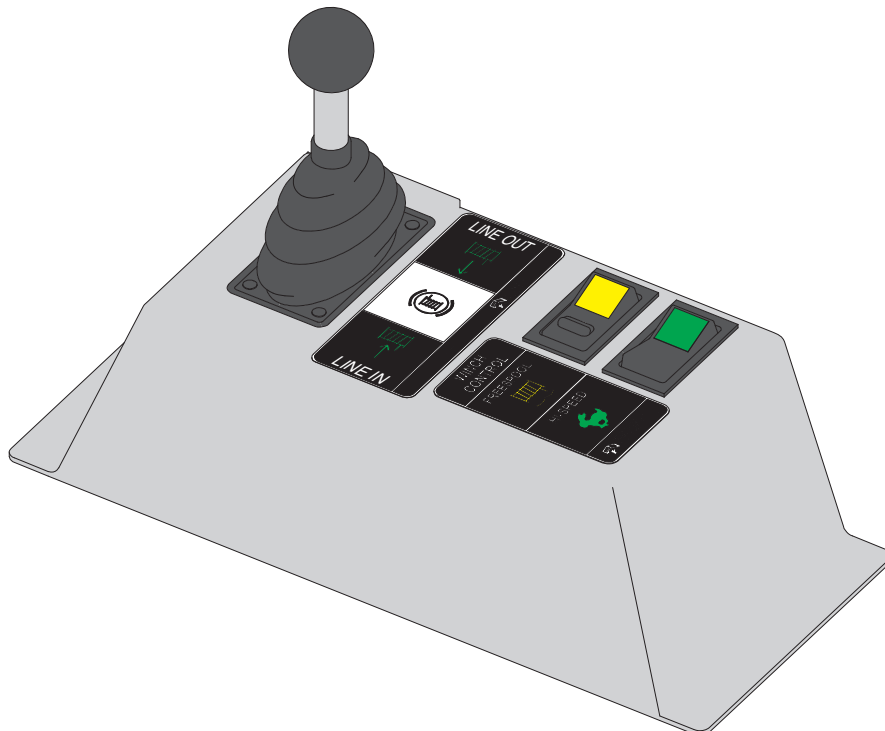


Figure 1-13 Winch Controls (Installation on CAT D6K2 shown. Your controls may vary.)

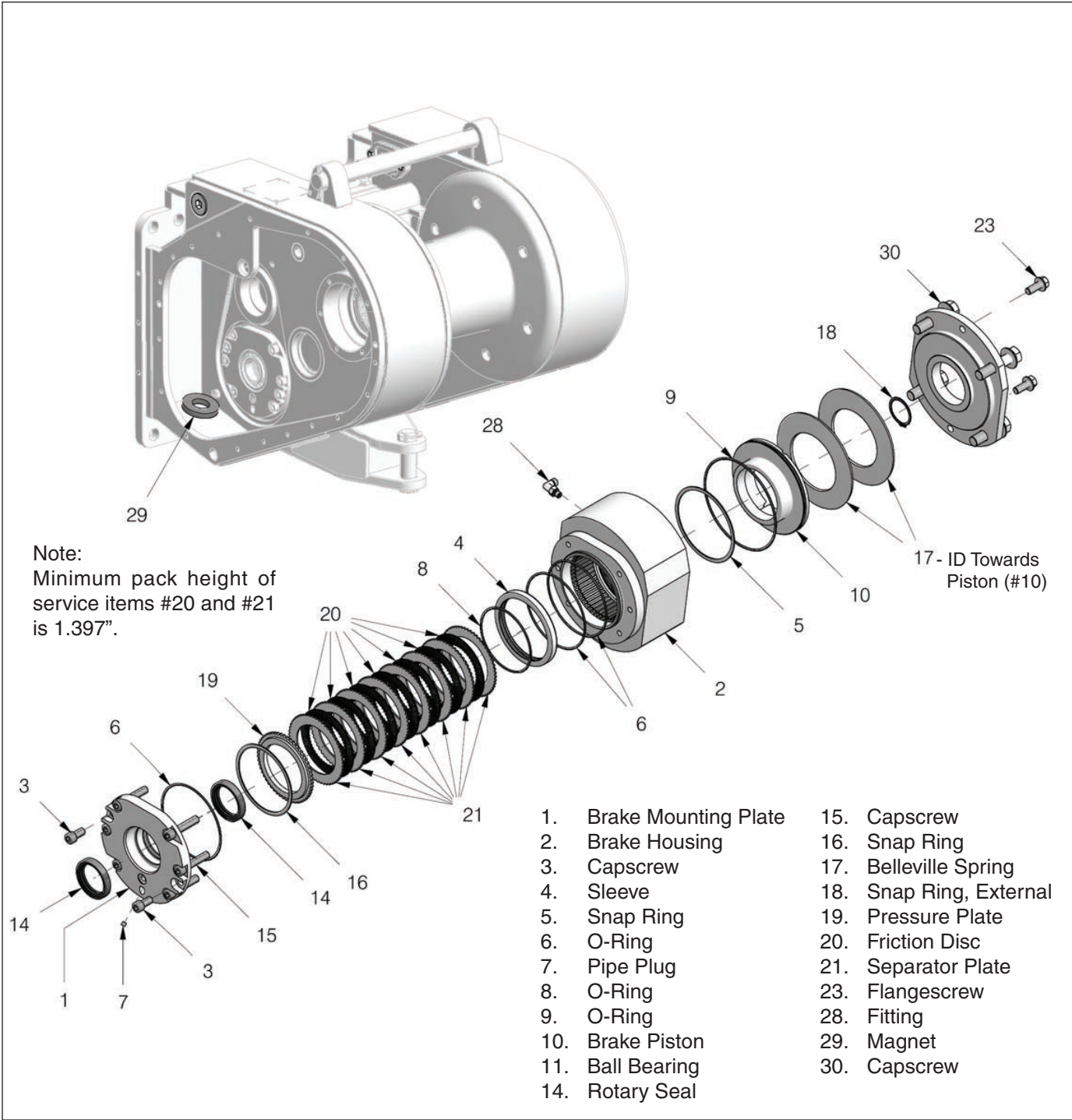


Figure 1-14 Brake

Brake (See Fig. 1-14)

The brake is a dry multi-disc spring applied design. The springs push against a piston that applies force to the friction discs and separator plates. The brake valve directs

pressurized oil to the piston and pushes back on the brake springs to release the brake. The separator plates have teeth that engage the splines inside the brake housing and are held stationary. Teeth in the friction discs engage the splines on the motor shaft and rotate with the hub.

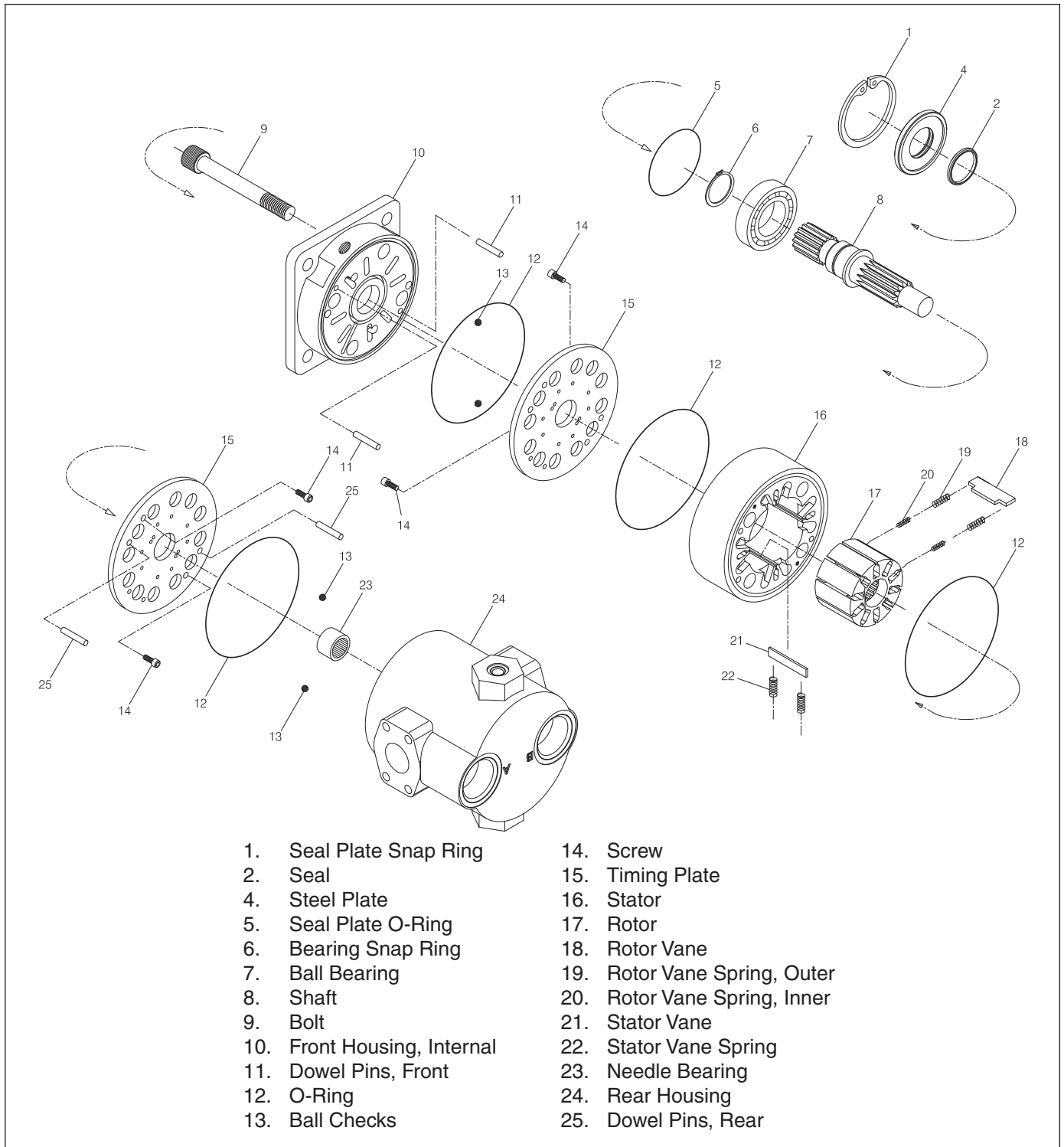


Figure 1-15 Motor, 2-Speed Vane

Motor (See Fig. 1-15)

The hydraulic motor is a dual displacement vane-type (see Figure 1-15). Winch speed is proportionally varied by input flow from the pump and/or the displacement of the motor.

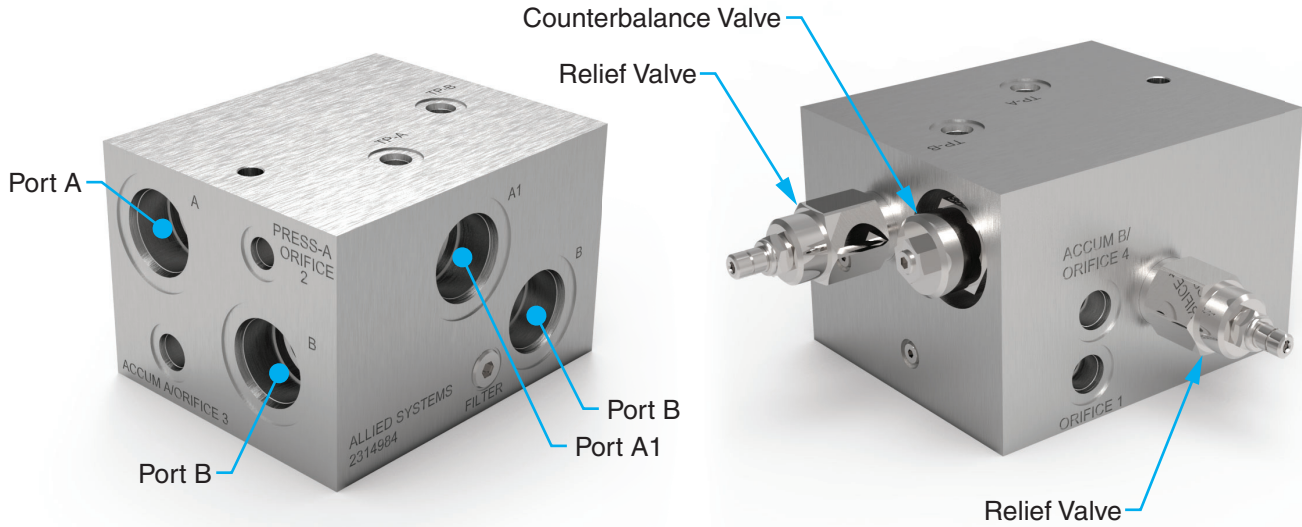


Figure 1-16 Counterbalance Relief Manifold

Counterbalance Relief Manifold (See Fig. 1-16)

The counterbalance relief (CBR) manifold houses the counterbalance valve and the high pressure relief valves. The counterbalance valve is a load holding valve that blocks return oil flow from the motor in the event supply pressure drops below a set point in **LINE-OUT** mode. The

counterbalance valve allows oil to free flow in the **LINE-IN** mode through a check valve. The high pressure relief valves act as an overload relief when supply pressure exceeds the setting of the valve.

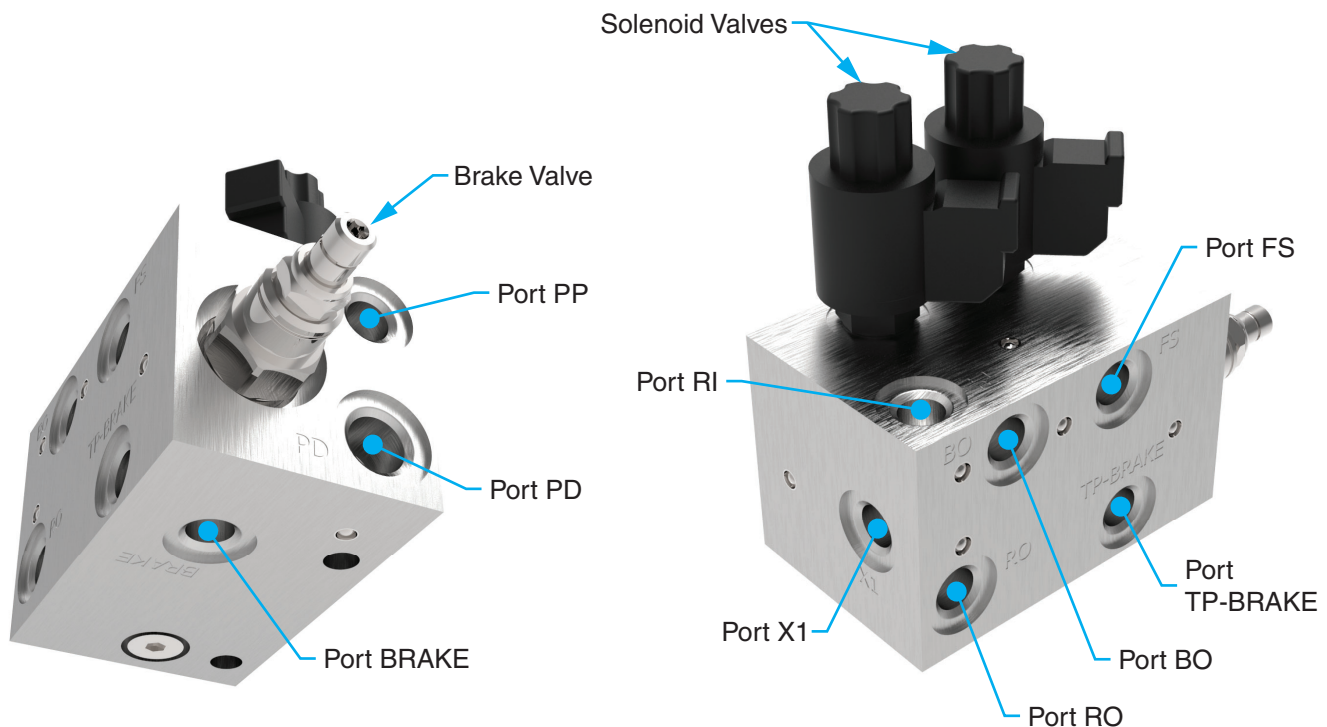


Figure 1-17 Control Manifold (Installations without DRAG-BRAKE)

Control Manifold on Installations without DRAG-BRAKE
(See Fig. 1-17)

The control manifold contains the brake valve, two solenoid valves and a shuttle valve to direct pilot pressure to release the **BRAKE** and control hydraulic motor displacement. The shuttle is used to send pilot pressure during either **LINE-IN** or **LINE-OUT** to the brake valve. When control

pressure rises to the brake release pressure setting, the brake valve sends pilot pressure to release the brake. The solenoids receive electrical signals from switches on the operator console. The solenoids valves release pilot pressure from the dozer to actuate the **FREESPOOL** function, or **HI-SPEED**.

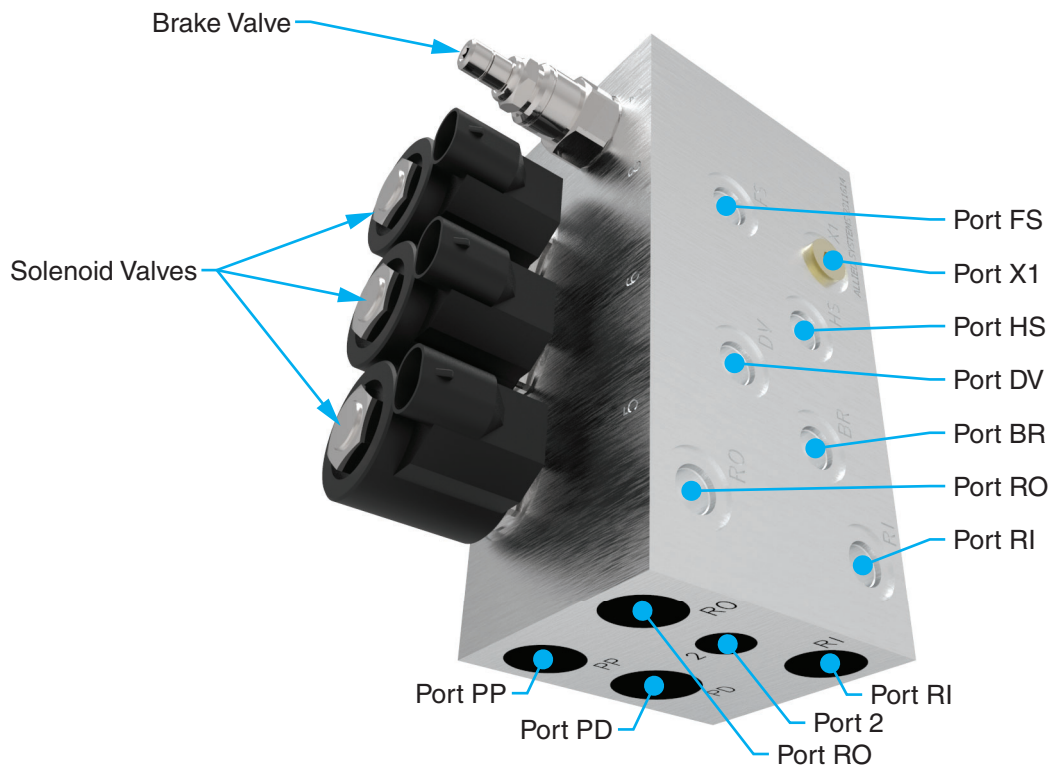


Figure 1-18 Control Manifold (Installations with DRAG-BRAKE)

Control Manifold on Installations with DRAG-BRAKE
(See Fig. 1-18)

The control manifold contains the brake valve, three solenoid valves and a shuttle valve to direct pilot pressure to release the parking brake, engage **FREESPOOL** or **DRAG-BRAKE**, and control hydraulic motor displacement. The shuttle is used to send pilot pressure during either **LINE-IN** or **LINE-OUT** to the brake valve. When control

pressure rises to the brake release pressure setting, the brake valve sends pilot pressure to release the brake. The solenoids receive electrical signals from switches on the operator console. The solenoids valves release pilot pressure from the dozer to actuate the **FREESPOOL** function, **DRAG-BRAKE**, or **HI-SPEED**.

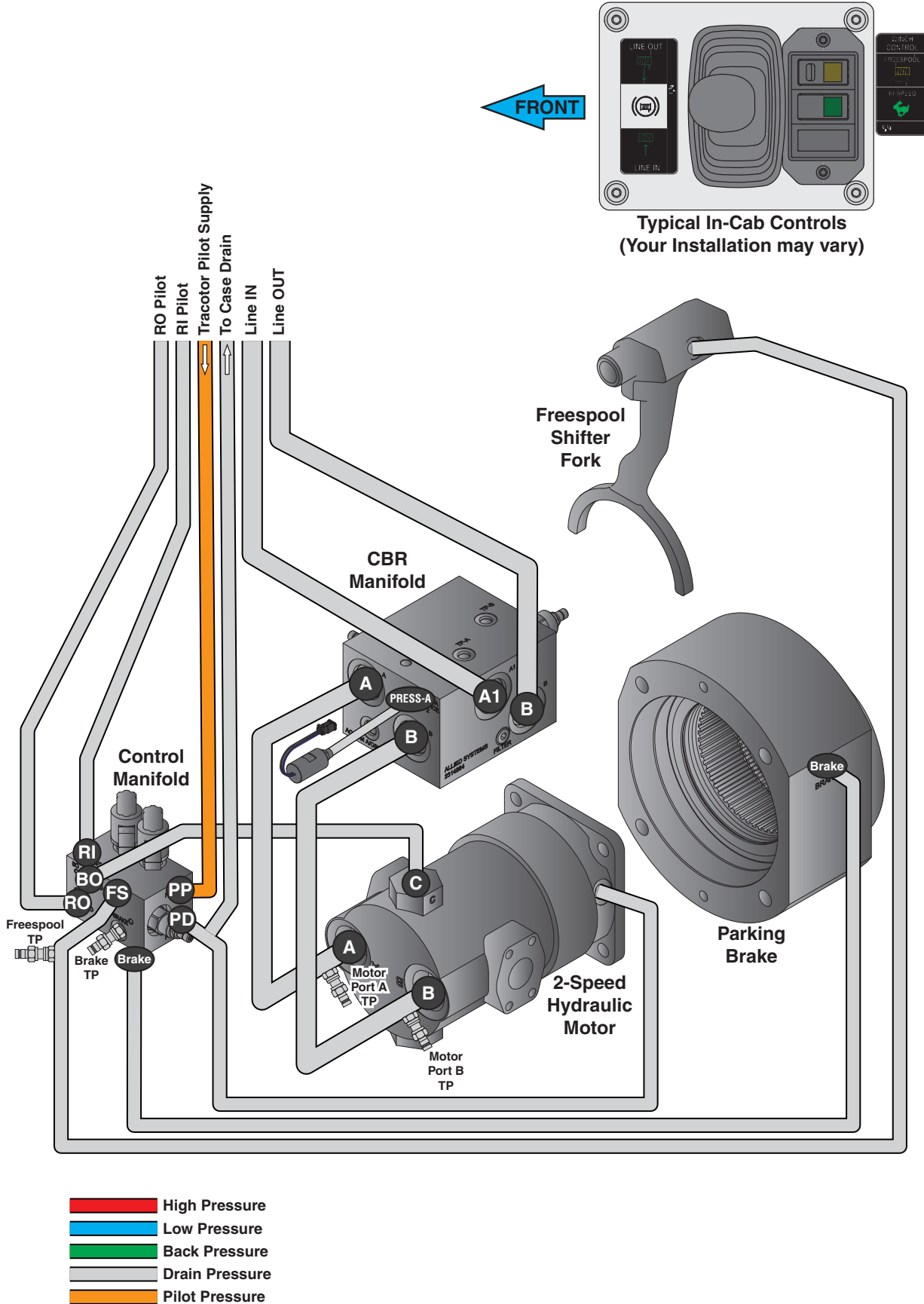


Figure 1-19 Sequence of Operation - BRAKE-ON, K371 and L39

Sequence of Operation - BRAKE-ON, K371 and L39

With control lever centered, the tractor ripper valve blocks flow to the winch.

Pilot pressure is present at the control manifold. All control lines are open to tank. The spring-applied holding brake locks the motor shaft from rotating.

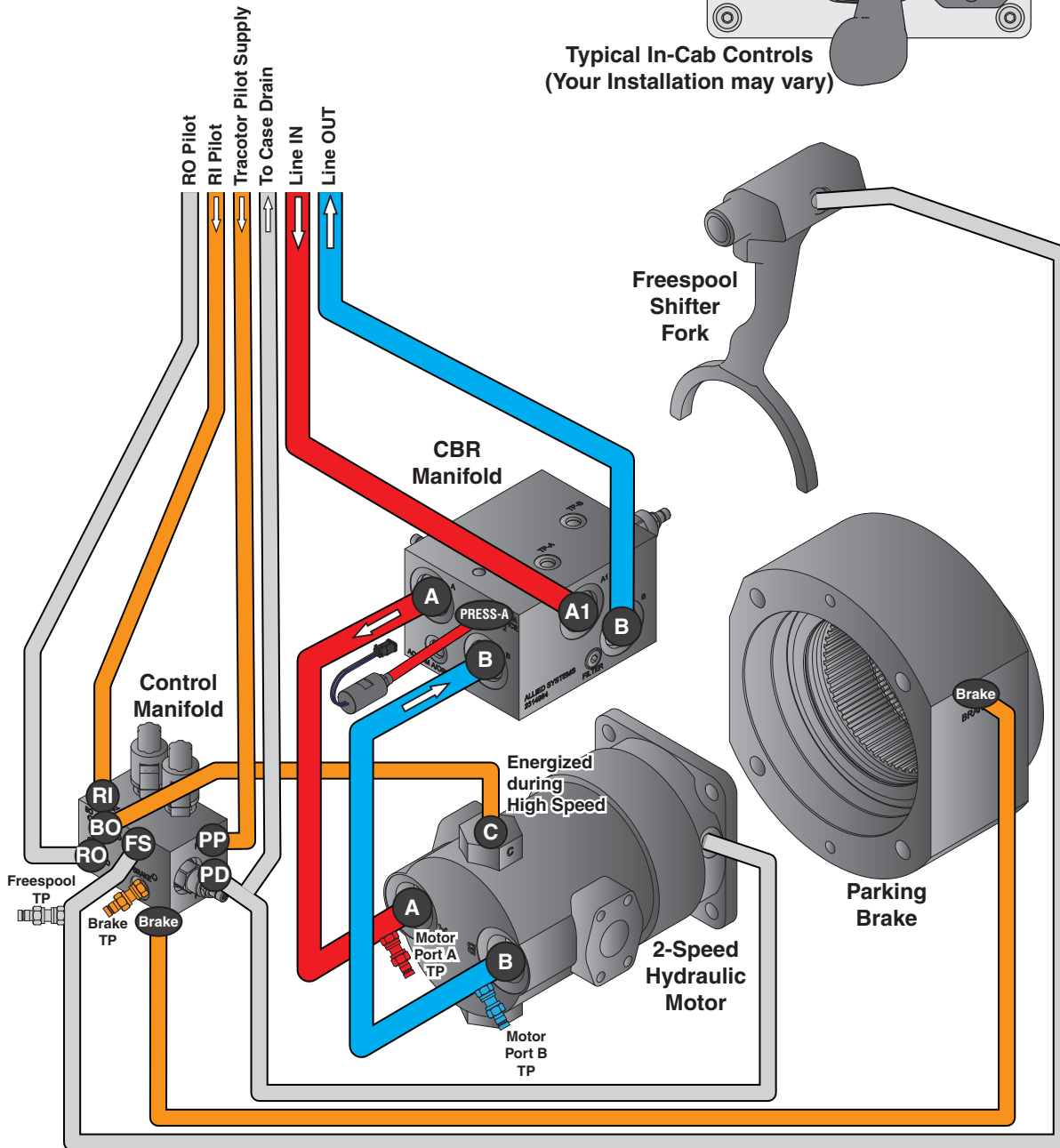
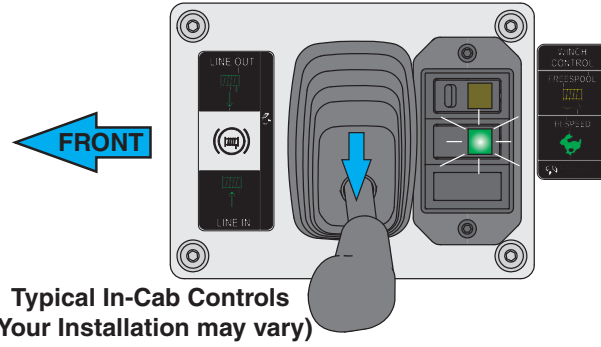


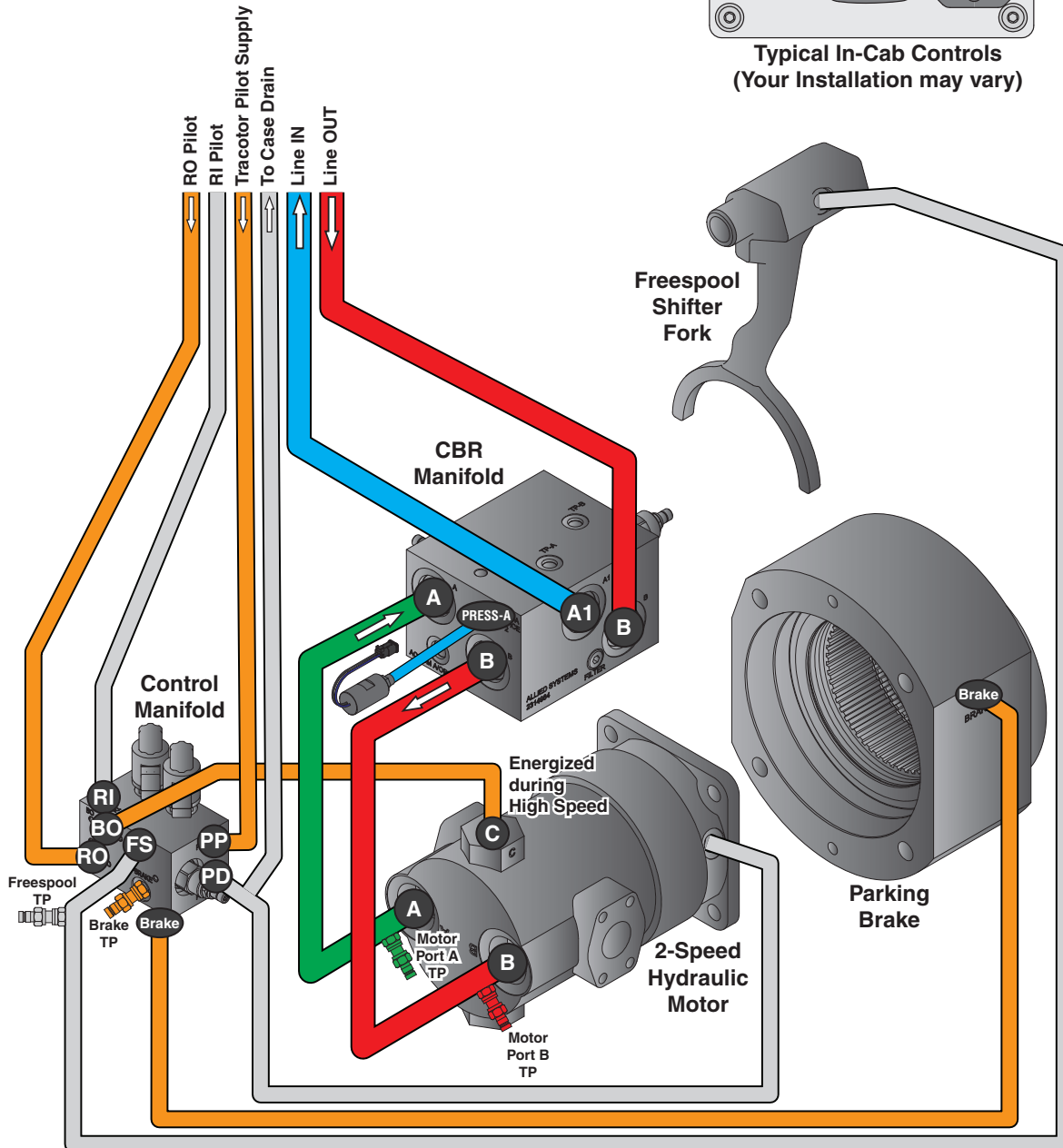
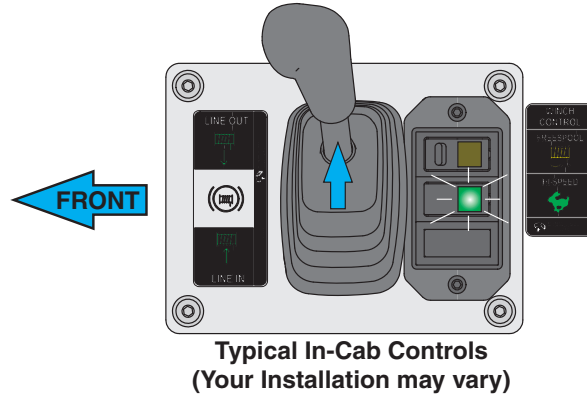
Figure 1-20 Sequence of Operation - LINE-IN, K371 and L39

Sequence of Operation - LINE-IN, K371 and L39

Pulling the control lever toward the operator commands the tractor ripper valve to send oil flowing to the winch, through the counterbalance relief manifold and to the motor "A" port. At the same time, pilot pressure from the control lever applies pressure to the RI port, through the shuttle valve, to the brake valve. At the set pressure, the brake valve directs pilot flow to release the brake.

If the operator selects **HI-SPEED** mode by the rocker switch on the control panel, an electric solenoid valve on the control manifold sends pilot pressure to the C port on the motor. The spool shifts to close half of the power cavities in the motor. Full pump flow now flows through the motor at half displacement, thus doubling the output rpm.

If the winch is pulling a load, the pressure at a pressure switch on the CBR manifold will increase. When pulling a heavy load, the pressure switch, which is normally closed, will open. This will disable **HI-SPEED** mode, forcing the motor to maximum displacement (low speed, high torque) ensuring that the winch can pull the load.



- █ High Pressure
- █ Low Pressure
- █ Back Pressure
- █ Drain Pressure
- █ Pilot Pressure

Figure 1-21 Sequence of Operation - LINE-OUT, K371 and L39

Sequence of Operation - LINE-OUT, K371 and L39

LINE-OUT operation is similar to **LINE-IN** except moving the control lever away from the operator reverses flow at the tractor ripper valve and directs flow through the counterbalance relief manifold to the motor “B” port and to the RO port on the control manifold, and returns through “A” port. Brake release operates the same as **LINE-IN** mode.

In **LINE-OUT** operation, oil flowing from motor port “A” to the counterbalance relief manifold is controlled by the counterbalance valve. The counterbalance valve maintains sufficient pressure in the motor outlet (A) line to prevent uncontrolled lowering of a load.

If the operator selects **HI-SPEED** mode by the rocker switch on the control panel, an electric solenoid valve on the control manifold sends pilot pressure to the C port on the motor. The spool shifts to close half of the power cavities in the motor. Full pump flow now flows through the motor at half displacement, thus doubling the output rpm.



WARNING

HI-SPEED must be disabled during LINE-OUT if there is a load attached to the wire rope.

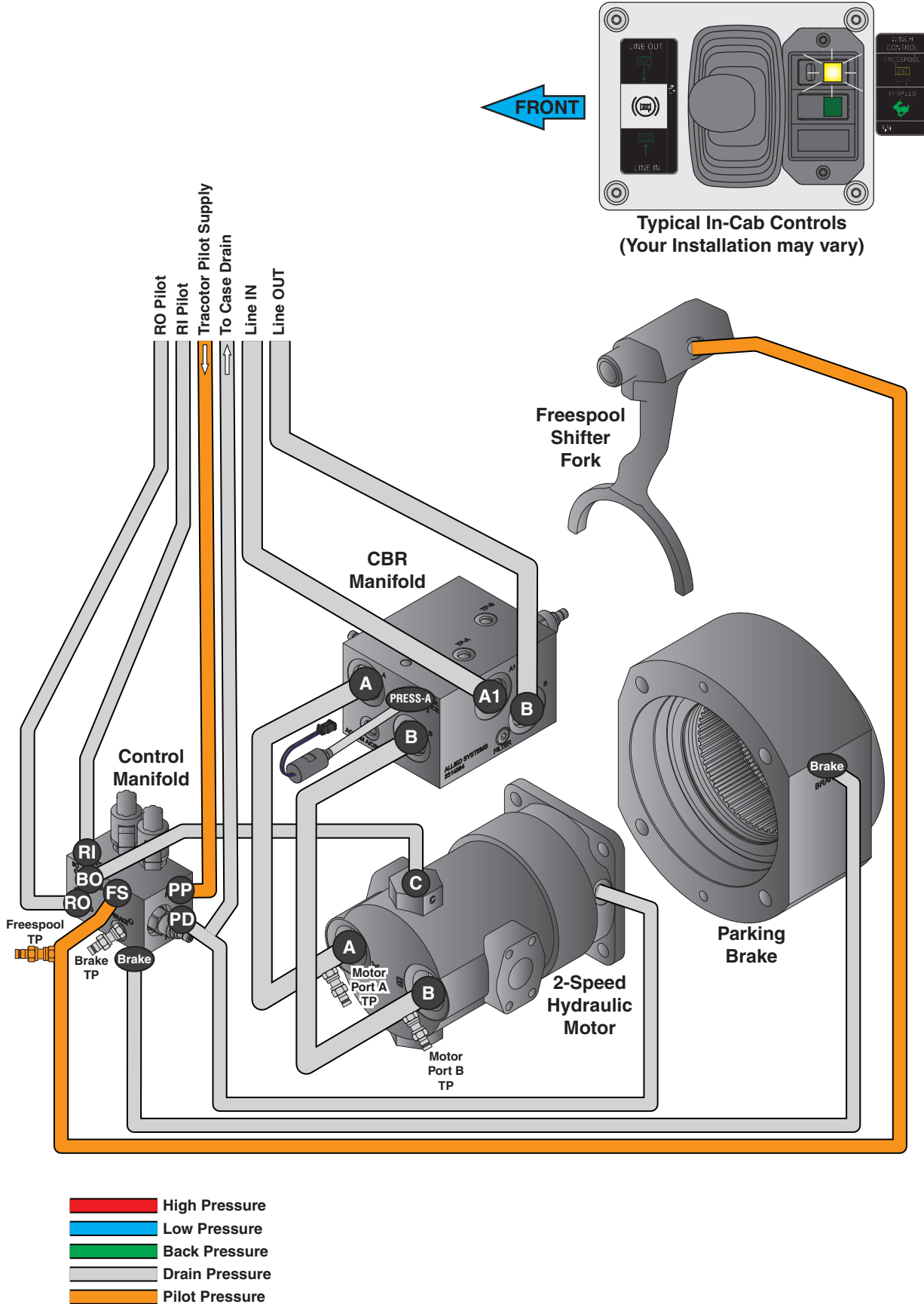


Figure 1-22 Sequence of Operation - FREESPOOL, K371 and L39

Sequence of Operation - FREESPOOL, K371 and L39

The operator moves the slide lock and depresses the **FREESPOOL** switch. By depressing the **FREESPOOL** switch, pilot oil pressure is diverted to the **FREESPOOL** piston. Pilot control pressure moves the **FREESPOOL** shifter fork, allowing the dental clutch to disengage the drum pinion gear from the intermediate gear. The gear train is disengaged from the drum gear so the wire rope can be pulled from the drum by hand.

The dental collar may not fully re-engage until the motor is powered in **LINE-IN** or **LINE-OUT**.



WARNING

FREESPOOL should not be used if there is a load on the wire rope. An uncontrolled release of the load will occur. Loss of the load can result in equipment damage, personal injury, or death.

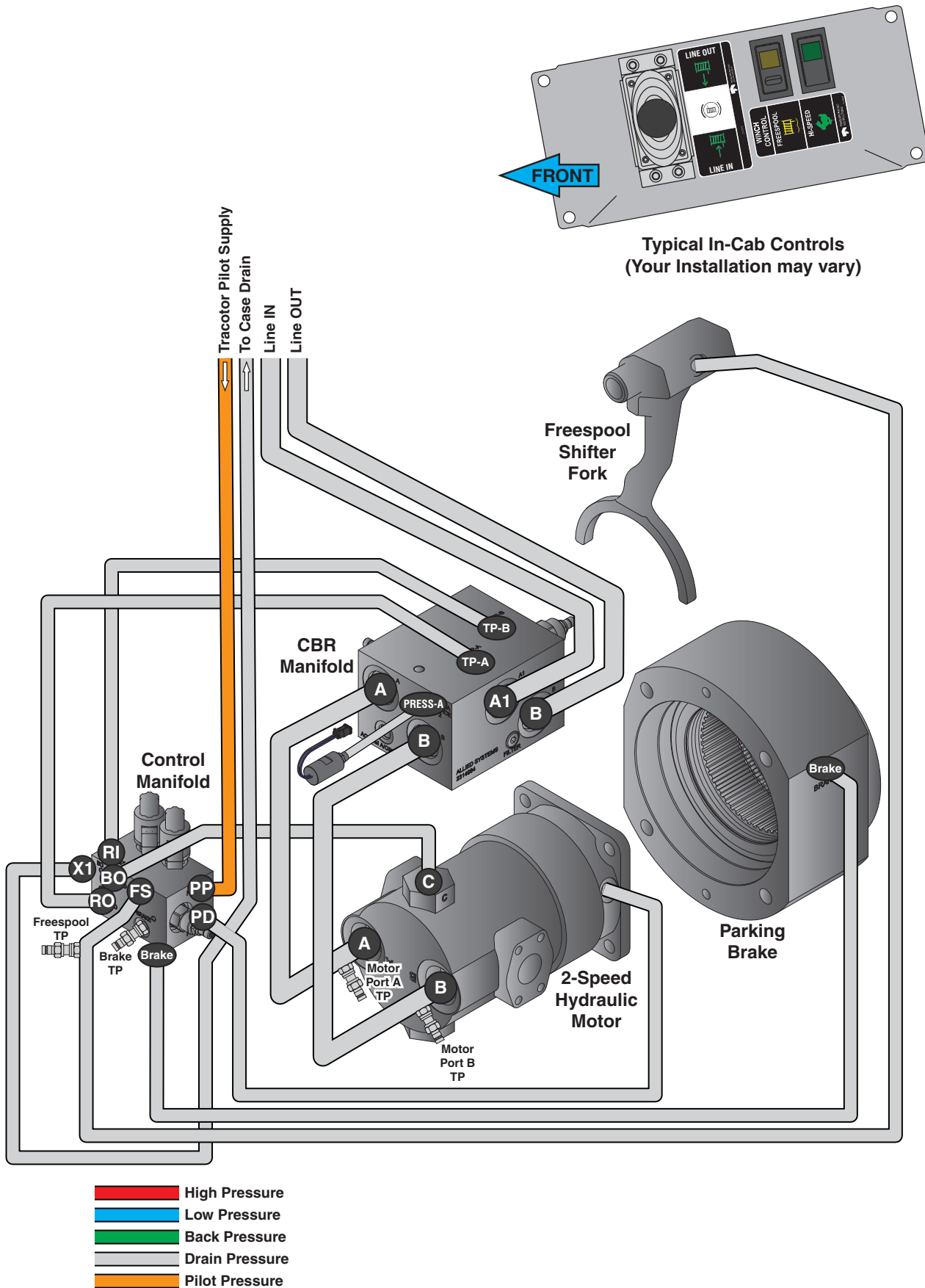


Figure 1-23 Sequence of Operation - BRAKE-ON, C805, R371, R42

Sequence of Operation - BRAKE-ON, C805, R371, R42

With control lever centered, the tractor ripper valve blocks flow to the winch.

Pilot pressure is present at the control manifold. All control lines are open to tank. The spring-applied holding brake locks the motor shaft from rotating.

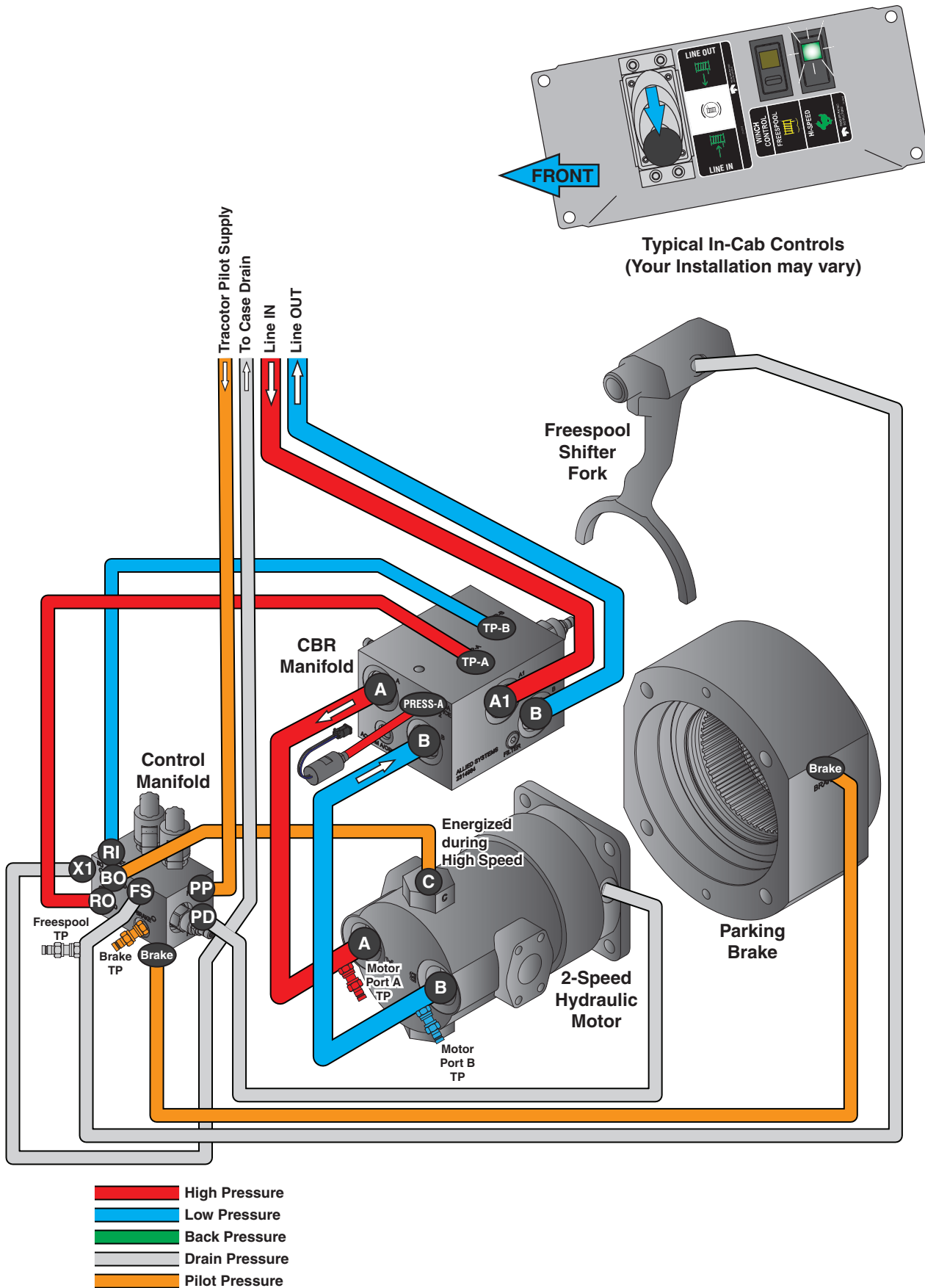


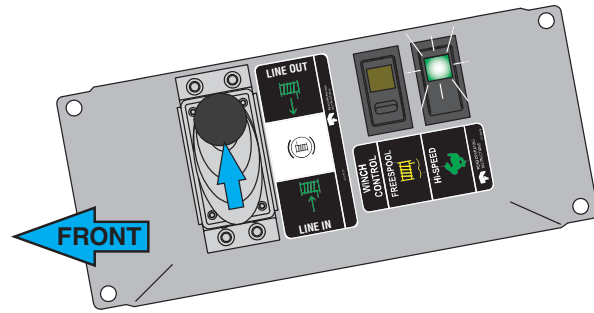
Figure 1-24 Sequence of Operation - LINE-IN, C805, R371, R42

Sequence of Operation - LINE-IN, C805, R371, R42

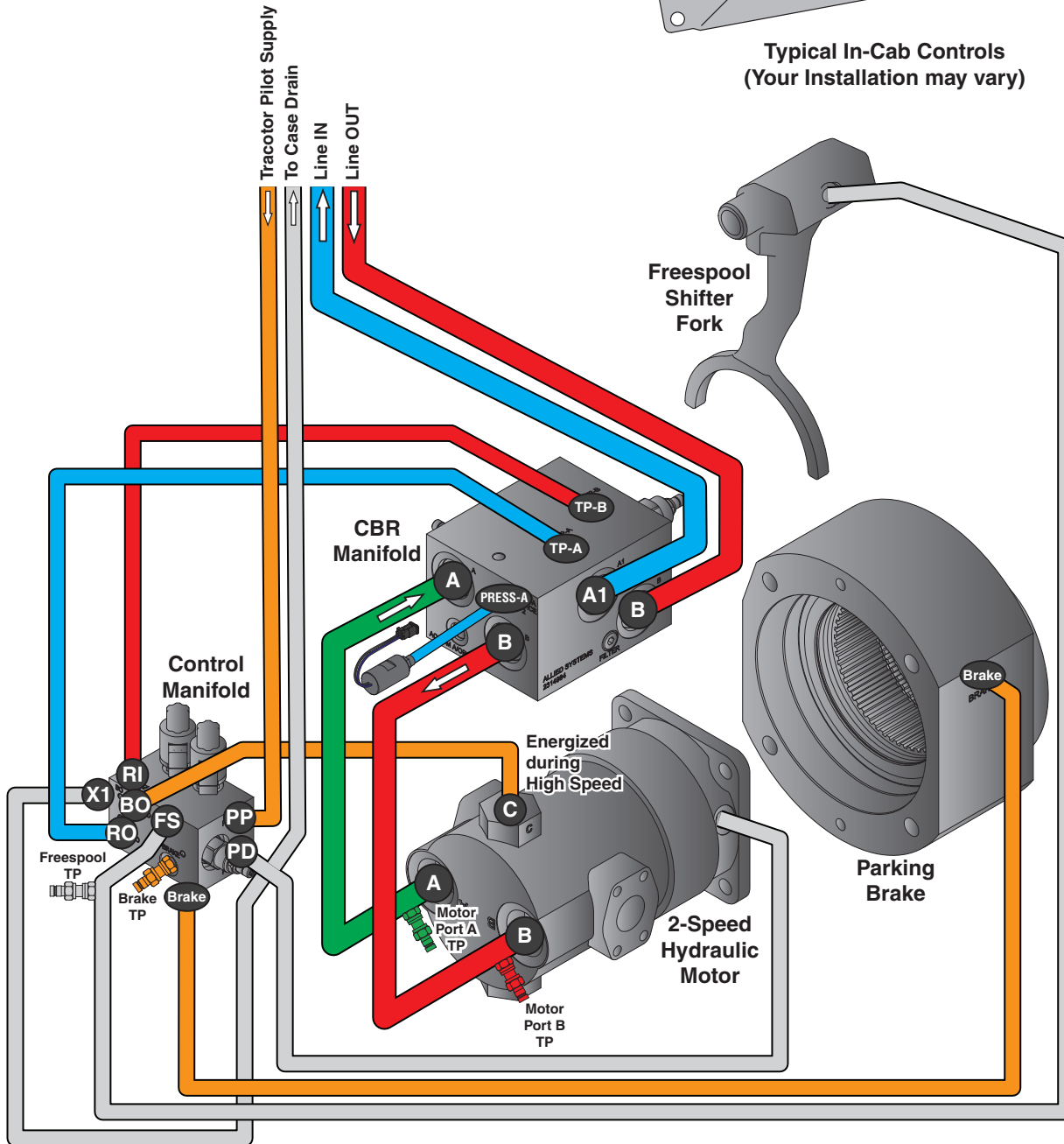
Pulling the control lever toward the operator commands the tractor ripper valve to send oil flowing to the winch, through the counterbalance relief manifold and to the motor "A" port. At the same time, high pressure from the CBR manifold applies pressure to the RO port, through the shuttle valve, to the brake valve. The brake valve directs pilot flow to release the brake.

If the operator selects **HI-SPEED** mode by the rocker switch on the control panel, an electric solenoid valve on the control manifold sends pilot pressure to the C port on the motor. The spool shifts to close half of the power cavities in the motor. Full pump flow now flows through the motor at half displacement, thus doubling the output rpm.

If the winch is pulling a load, the pressure at a pressure switch on the CBR manifold will increase. When pulling a heavy load, the pressure switch, which is normally closed, will open. This will disable **HI-SPEED** mode, forcing the motor to maximum displacement (low speed, high torque) ensuring that the winch can pull the load.



Typical In-Cab Controls
(Your Installation may vary)



- █ High Pressure
- █ Low Pressure
- █ Back Pressure
- █ Drain Pressure
- █ Pilot Pressure

Figure 1-25 Sequence of Operation - LINE-OUT, C805, R371, R42

Sequence of Operation - LINE-OUT, C805, R371, R42

LINE-OUT operation is similar to **LINE-IN** except moving the control lever away from the operator reverses flow at the tractor ripper valve and directs flow through the counterbalance relief manifold to the motor “B” port and to the RI port on the control manifold, and returns through “A” port. Brake release operates the same as **LINE-IN** mode.

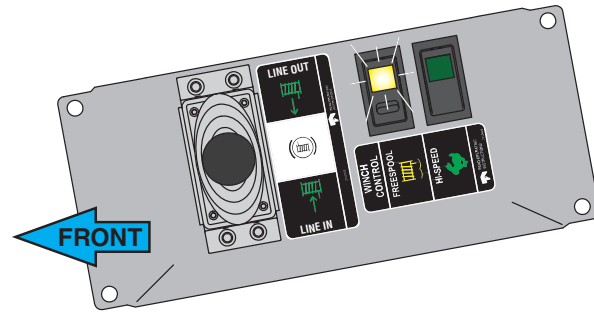
In **LINE-OUT** operation, oil flowing from motor port “A” to the counterbalance relief manifold is controlled by the counterbalance valve. The counterbalance valve maintains sufficient pressure in the motor outlet (A) line to prevent uncontrolled lowering of a load.

If the operator selects **HI-SPEED** mode by the rocker switch on the control panel, an electric solenoid valve on the control manifold sends pilot pressure to the C port on the motor. The spool shifts to close half of the power cavities in the motor. Full pump flow now flows through the motor at half displacement, thus doubling the output rpm.

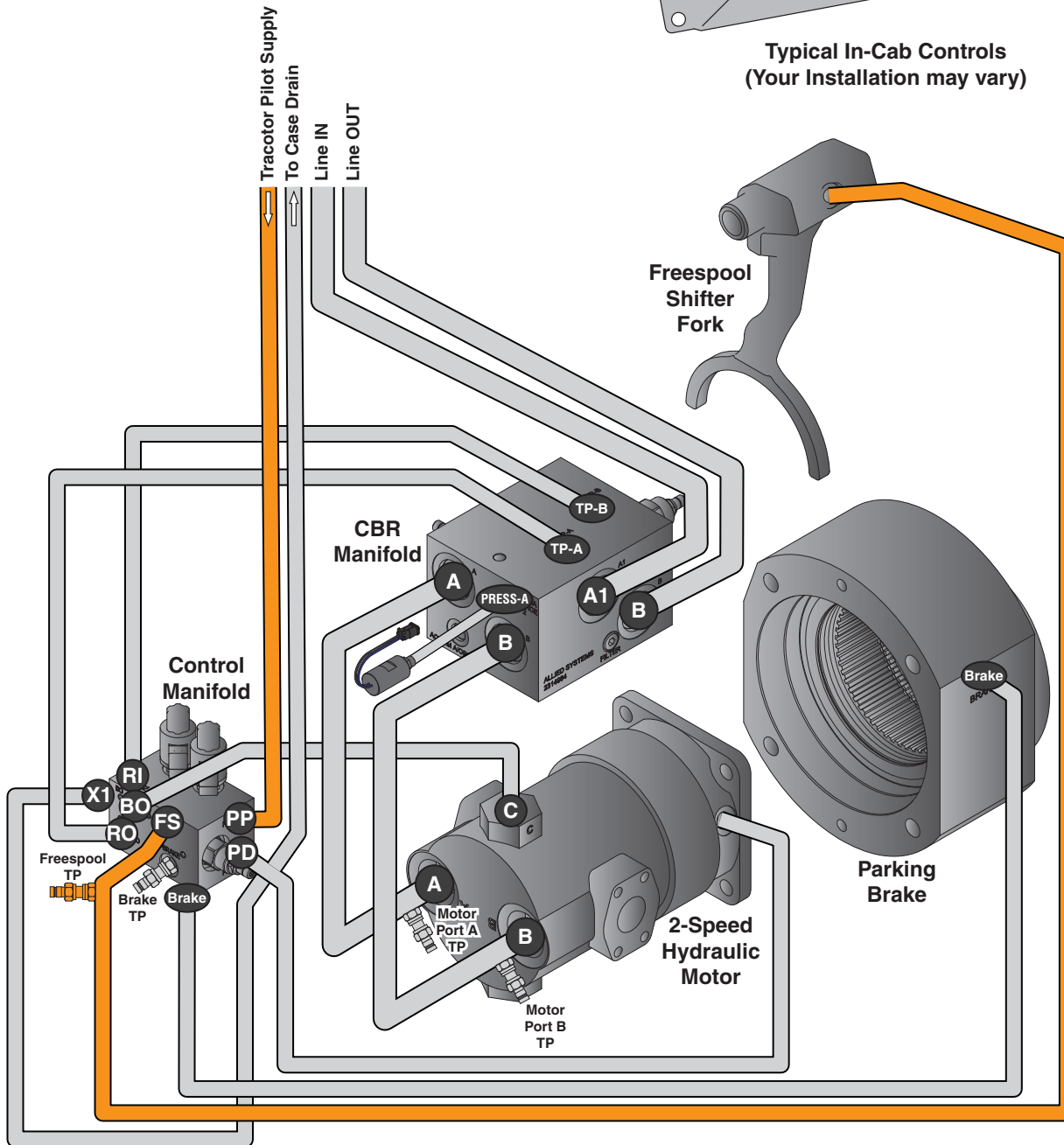


WARNING

HI-SPEED must be disabled during LINE-OUT if there is a load attached to the wire rope.



Typical In-Cab Controls
(Your Installation may vary)



- High Pressure
- Low Pressure
- Back Pressure
- Drain Pressure
- Pilot Pressure

Figure 1-26 Sequence of Operation - FREESPOOL, C805, R371, R42

Sequence of Operation - FREESPOOL, C805, R371, R42

The operator moves the slide lock and depresses the **FREESPOOL** switch. By depressing the **FREESPOOL** switch, pilot oil pressure is diverted to the **FREESPOOL** piston. Pilot control pressure moves the **FREESPOOL** shifter fork, allowing the dental clutch to disengage the drum pinion gear from the intermediate gear. The gear train is disengaged from the drum gear so the wire rope can be pulled from the drum by hand.

The dental collar may not fully re-engage until the motor is powered in **LINE-IN** or **LINE-OUT**.



WARNING

FREESPOOL should not be used if there is a load on the wire rope. An uncontrolled release of the load will occur. Loss of the load can result in equipment damage, personal injury, or death.

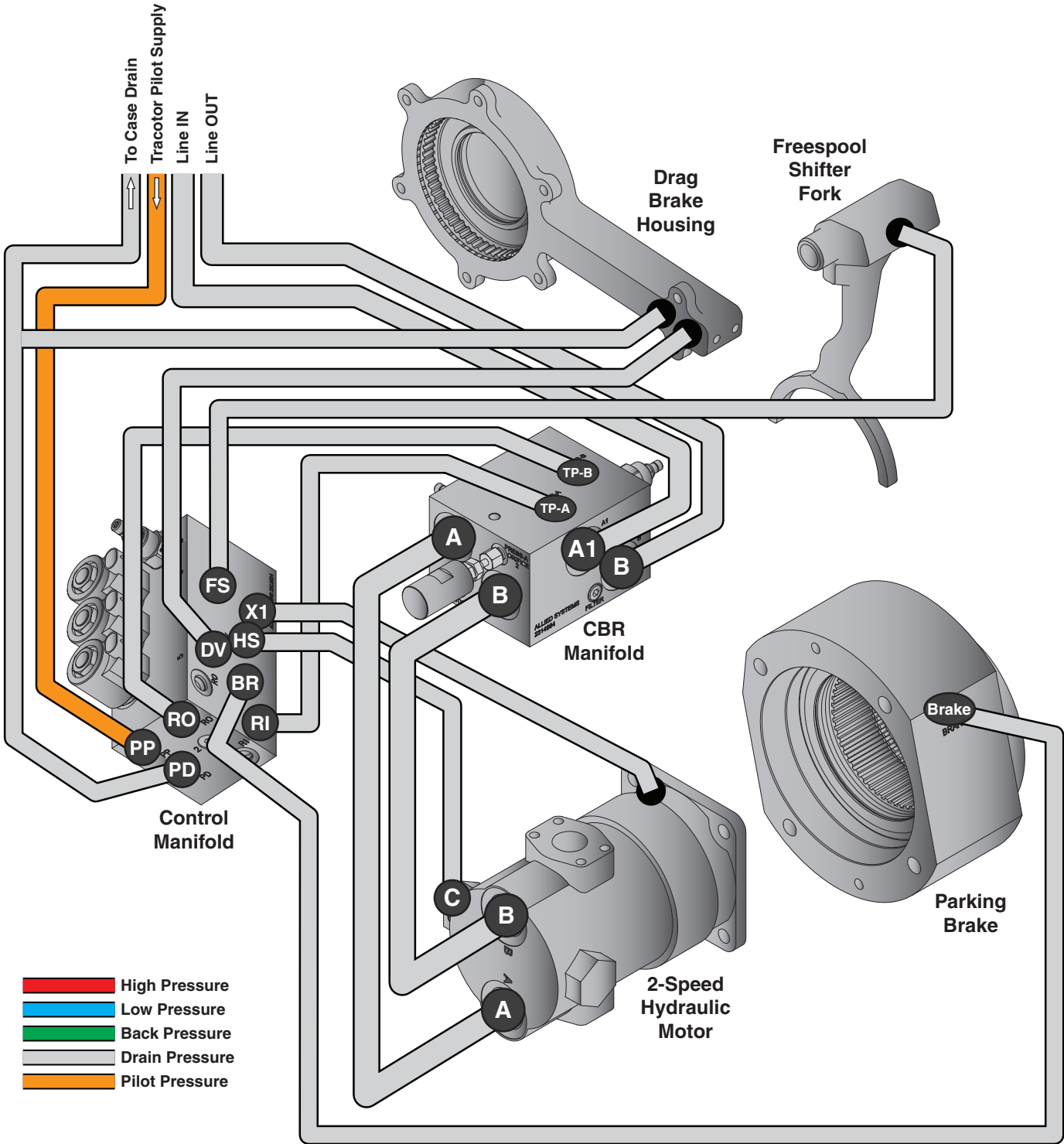


Figure 1-27 Sequence of Operation - BRAKE-ON, Y46F

Sequence of Operation - BRAKE-ON, Y46F

With control lever centered, the tractor ripper valve blocks flow to the winch.

Pilot pressure is present at the control manifold. All control lines are open to tank. The spring-applied holding brake locks the motor shaft from rotating.

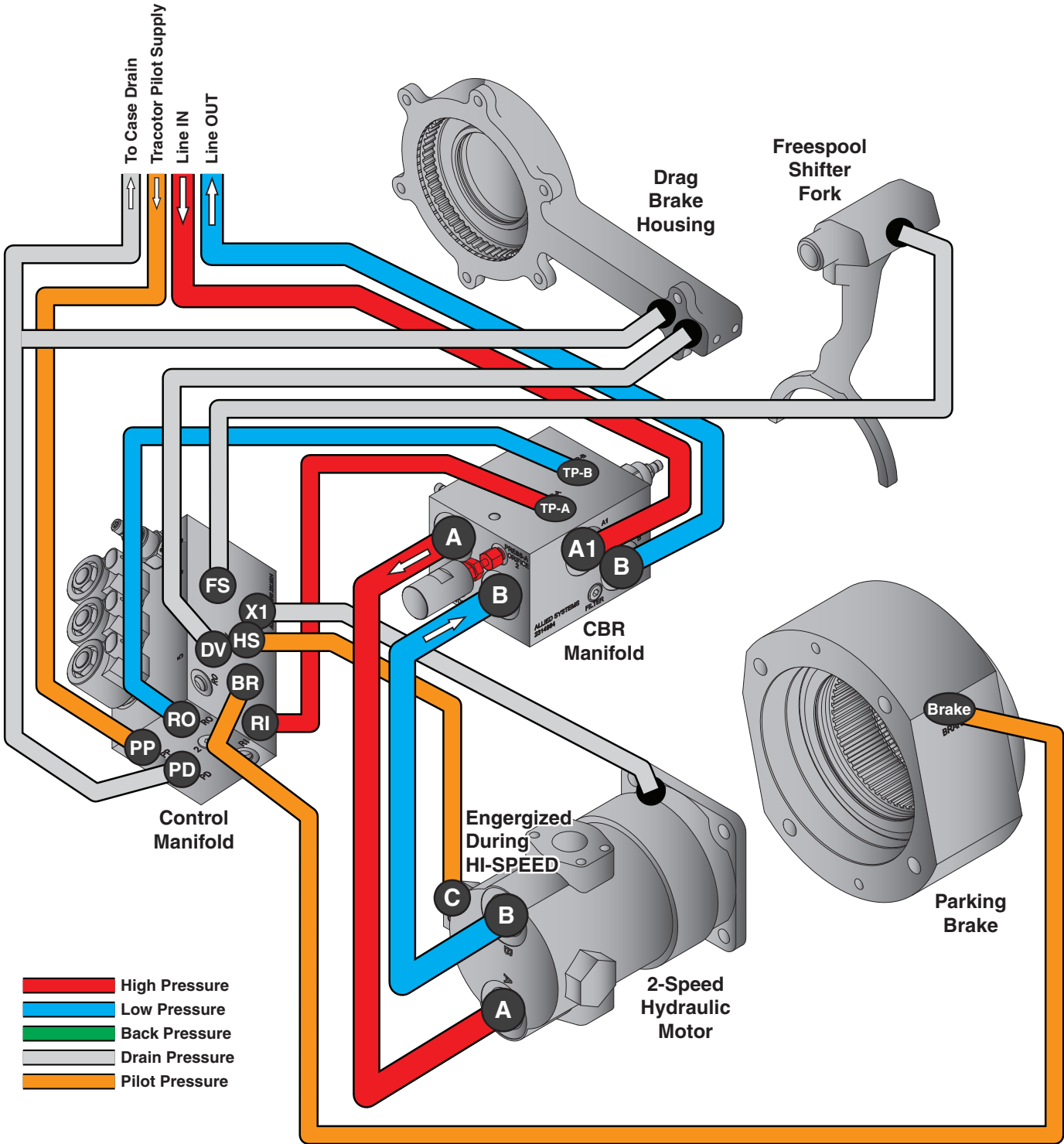


Figure 1-28 Sequence of Operation - LINE-IN, Y46F

Sequence of Operation - LINE-IN, Y46F

Activating **LINE-IN** commands the tractor ripper valve to send oil flowing to the winch, through the counterbalance relief manifold and to the motor "A" port. At the same time, high pressure from the CBR manifold applies pressure to the RI port, through the shuttle valve, to the brake valve. The brake valve directs pilot flow to release the brake.

If the operator selects **HI-SPEED** mode, an electric solenoid valve on the control manifold sends pilot pressure to the C port on the motor. The spool shifts to close half of the power cavities in the motor. Full pump flow now flows through the motor at half displacement, thus doubling the output rpm.

If the winch is pulling a load, the pressure at a pressure switch on the CBR manifold will increase. When pulling a heavy load, the pressure switch, which is normally closed, will open. This will disable **HI-SPEED** mode, forcing the motor to maximum displacement (low speed, high torque) ensuring that the winch can pull the load.

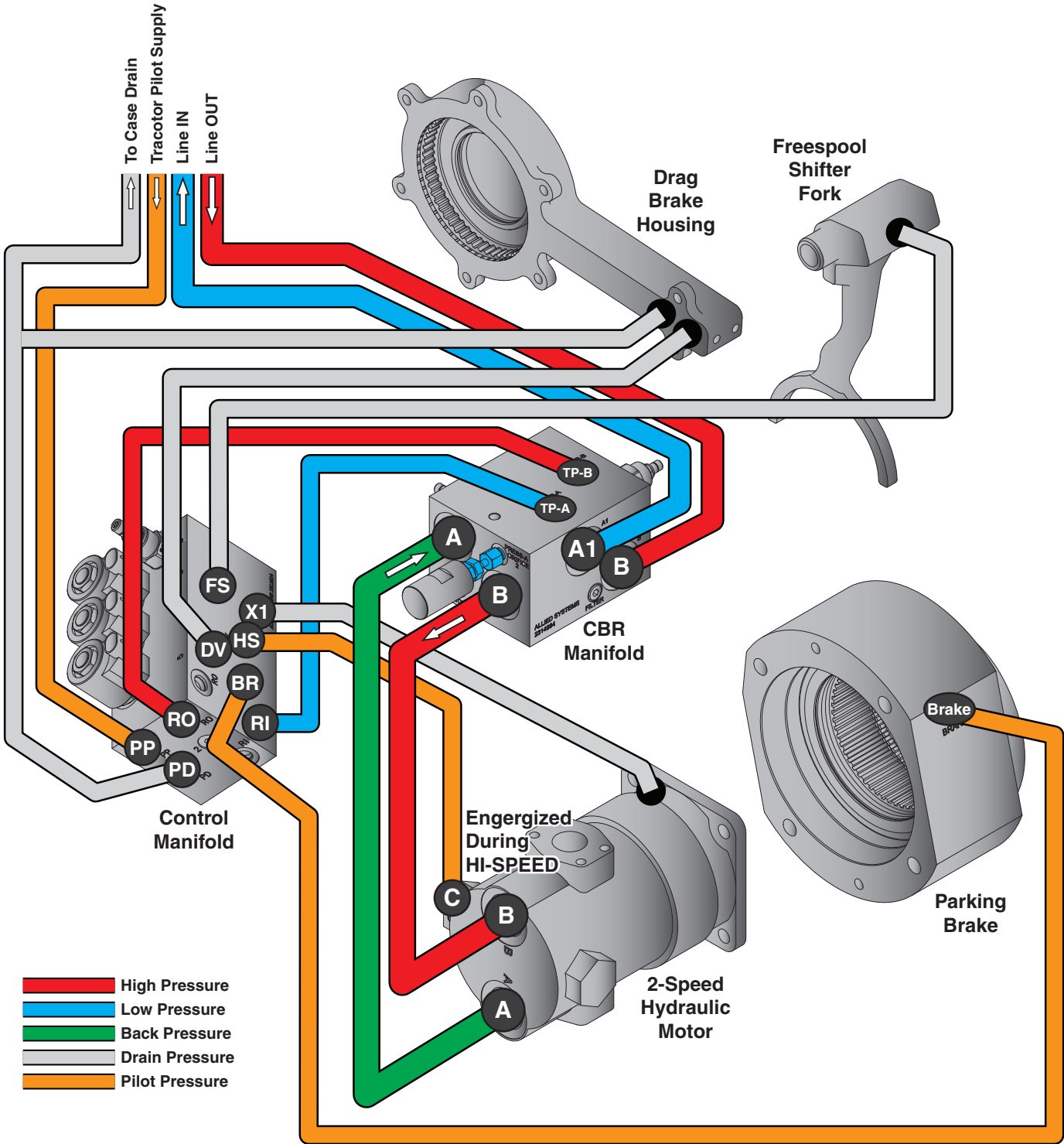


Figure 1-29 Sequence of Operation - LINE-OUT, Y46F

Sequence of Operation - LINE-OUT, Y46F

LINE-OUT operation is similar to **LINE-IN** except **LINE-OUT** reverses flow at the tractor ripper valve and directs flow through the counterbalance relief manifold to the motor “B” port and to the RO port on the control manifold, and returns through “A” port. Brake release operates the same as **LINE-IN** mode.

In **LINE-OUT** operation, oil flowing from motor port “A” to the counterbalance relief manifold is controlled by the counterbalance valve. The counterbalance valve maintains sufficient pressure in the motor outlet (A) line to prevent uncontrolled lowering of a load.

If the operator selects **HI-SPEED** mode, an electric solenoid valve on the control manifold sends pilot pressure to the C port on the motor. The spool shifts to close half of the power cavities in the motor. Full pump flow now flows through the motor at half displacement, thus doubling the output rpm.



WARNING

HI-SPEED must be disabled during LINE-OUT if there is a load attached to the wire rope.

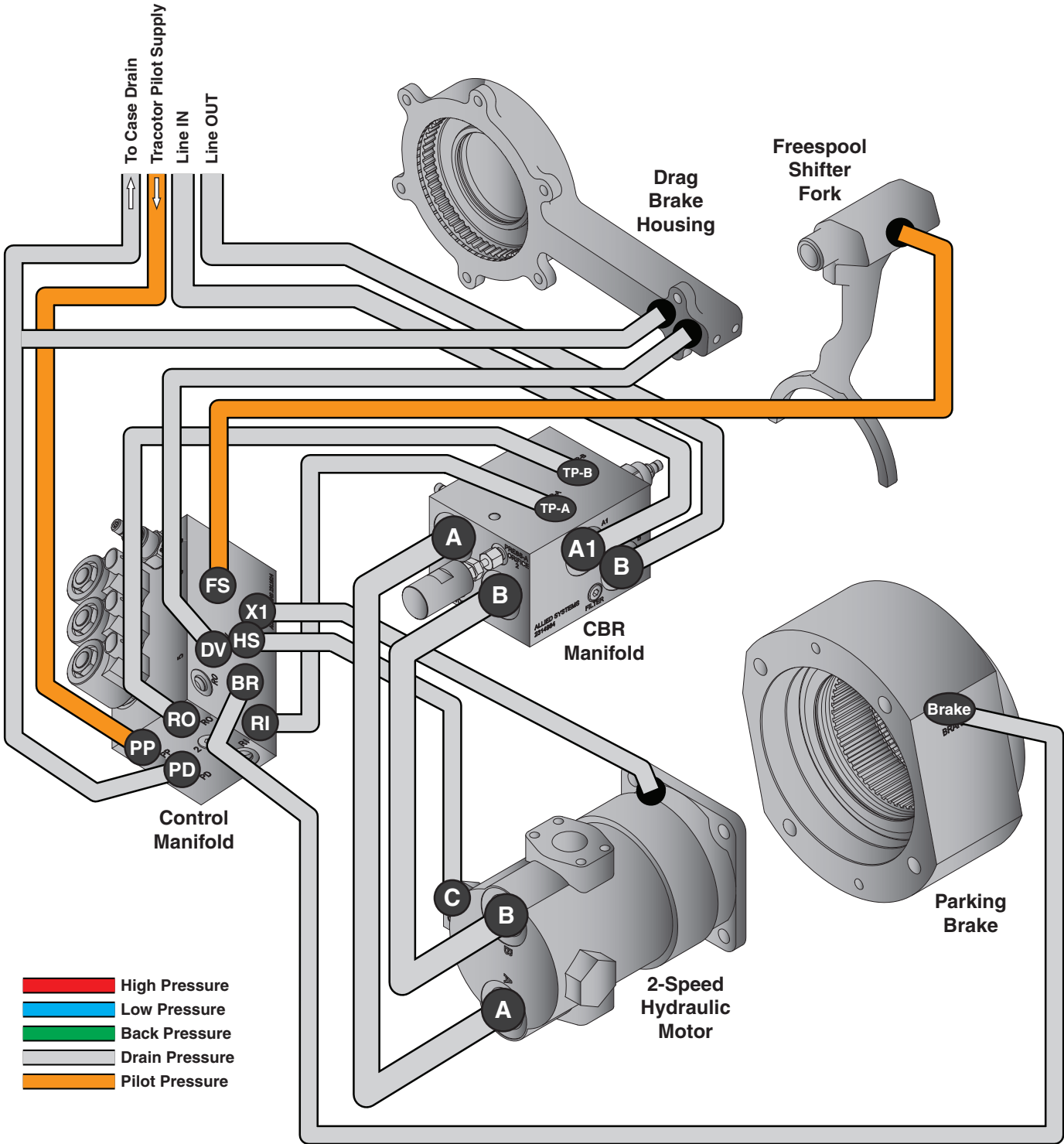


Figure 1-30 Sequence of Operation - FREESPOOL, Y46F

Sequence of Operation - FREESPOOL, Y46F

When **FREESPOOL** is activated, pilot oil pressure is diverted to the **FREESPOOL** piston. Pilot control pressure moves the **FREESPOOL** shifter fork, allowing the dental clutch to disengage the drum pinion gear from the intermediate gear. The gear train is disengaged from the drum gear so the wire rope can be pulled from the drum by hand.

The dental collar may not fully re-engage until the motor is powered in **LINE-IN** or **LINE-OUT**.



WARNING

FREESPOOL should not be used if there is a load on the wire rope. An uncontrolled release of the load will occur. Loss of the load can result in equipment damage, personal injury, or death.

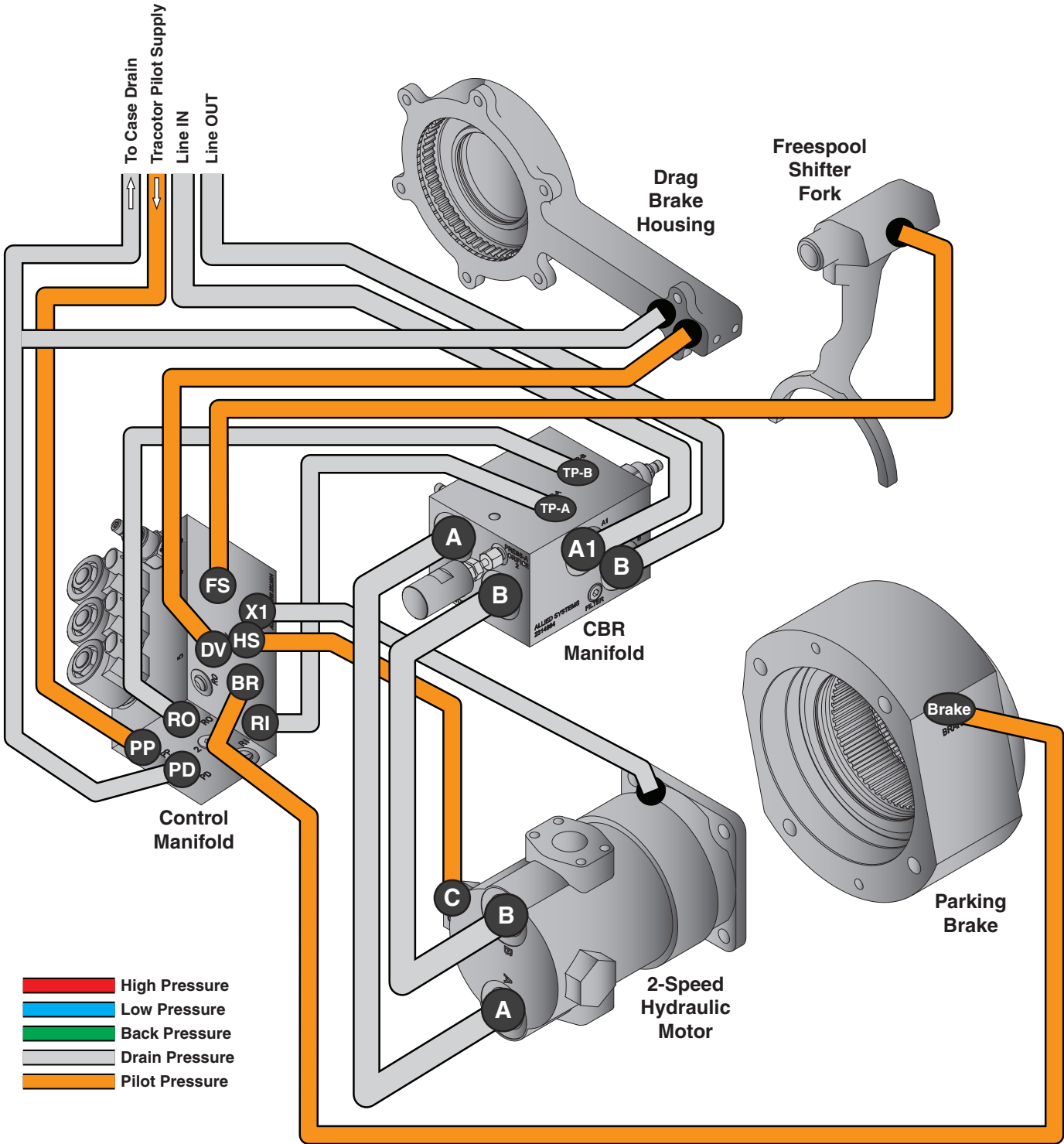


Figure 1-31 Sequence of Operation - DRAG-BRAKE, Y46F

Sequence of Operation - DRAG-BRAKE, Y46F

When **DRAG-BRAKE** is activated, pilot oil pressure is diverted to the **FREESPOOL** piston, the parking brake, the drag brake, and the **HI-SPEED** port on the motor.

Pilot control pressure moves the **FREESPOOL** shifter fork, allowing the dental clutch to disengage the drum pinion gear from the intermediate gear. The gear train is disengaged from the drum gear.

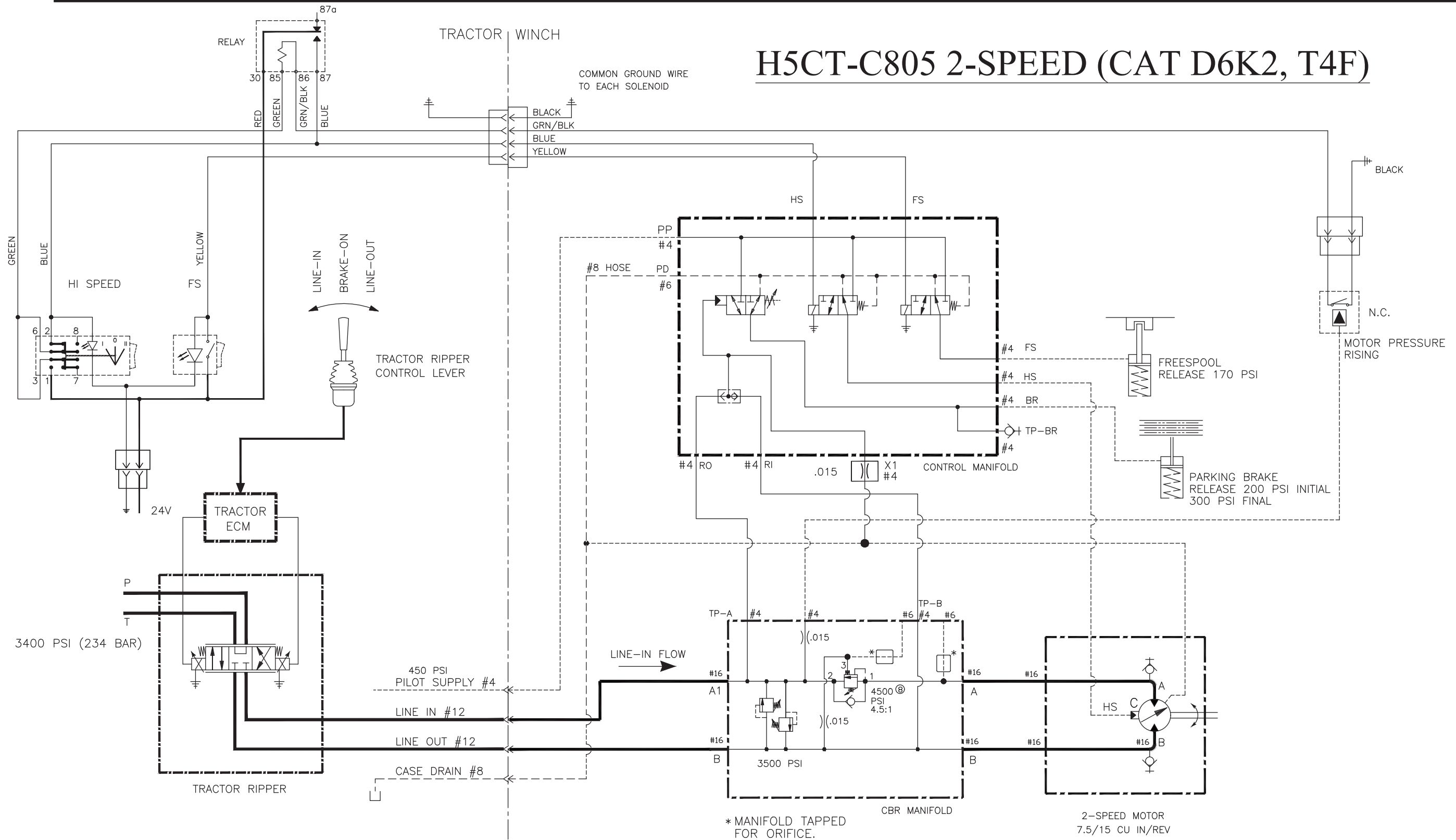
Pilot control pressure engages the drag brake. This supplies some amount of resistance to rotation of the drum, but doesn't lock it, allowing the vehicle to drive away from a load, while keeping the wire rope taut.



WARNING

DRAG-BRAKE should not be used to lower a suspended load or a load that can slide down a slope.

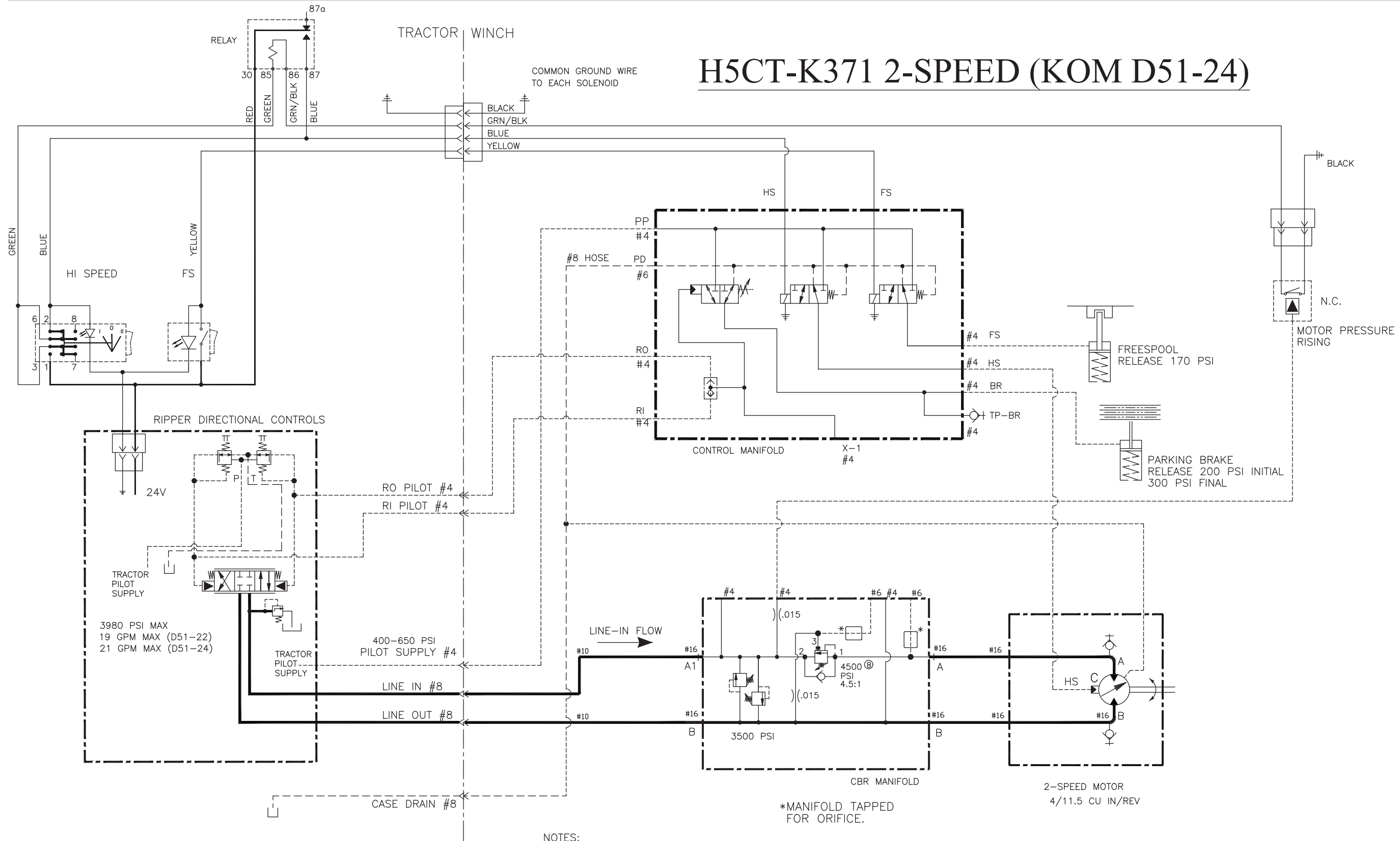
H5CT-C805 2-SPEED (CAT D6K2, T4F)



NOTES:
1. DETAIL FOR COILS. ALL EQUIPPED WITH TRANSIENT VOLTAGE SUPPRESSOR

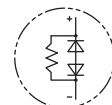


Figure 1-32 H5C Hydraulic/Electrical Schematic, Caterpillar D6K2 T4f (C805)



NOTES:

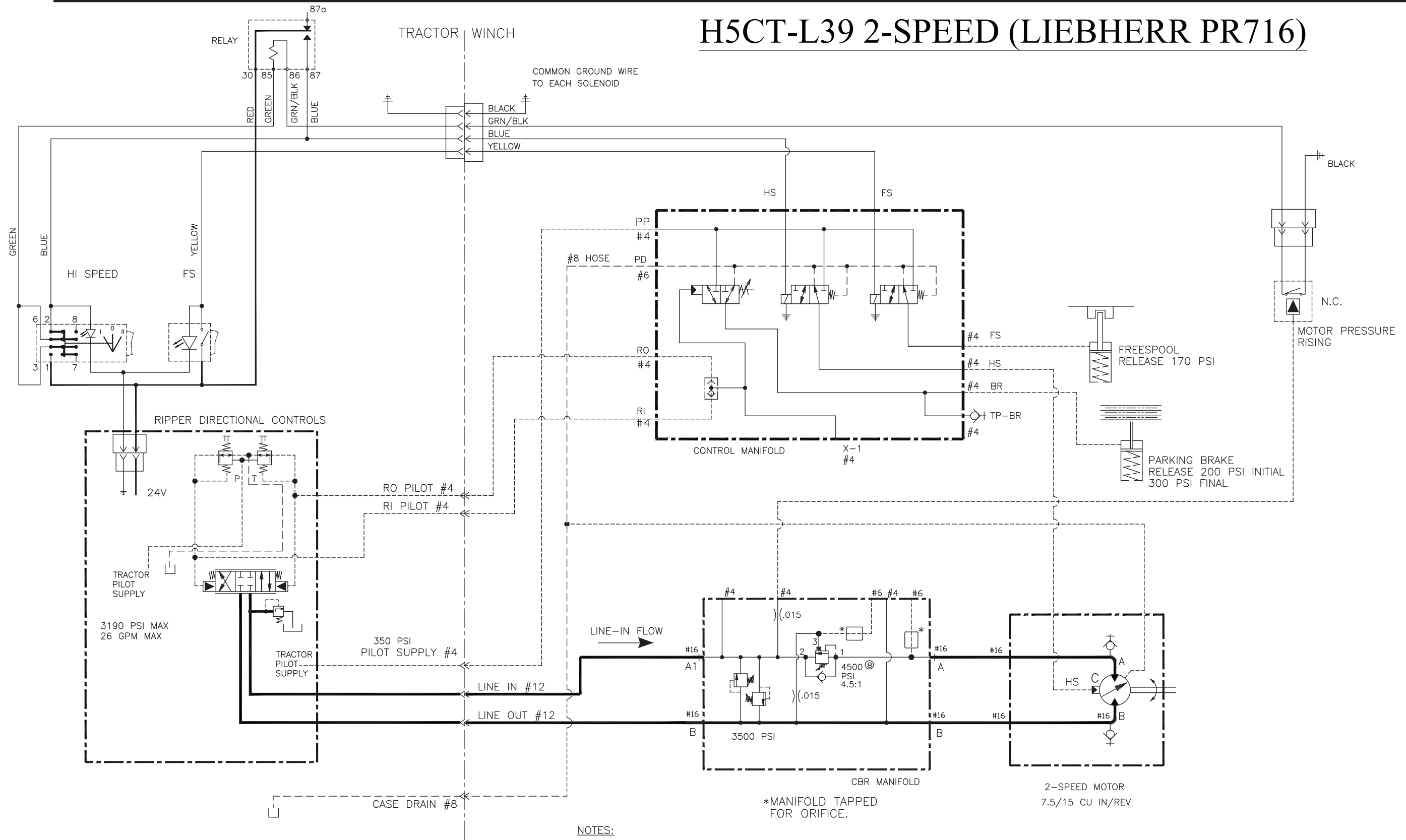
1. DETAIL FOR COILS. ALL EQUIPPED WITH TRANSIENT VOLTAGE SUPPRESSOR



*MANIFOLD TAPPED FOR ORIFICE.

Figure 1-33 H5C Hydraulic/Electrical Schematic, Komatsu D51-24 (K371)

H5CT-L39 2-SPEED (LIEBHERR PR716)



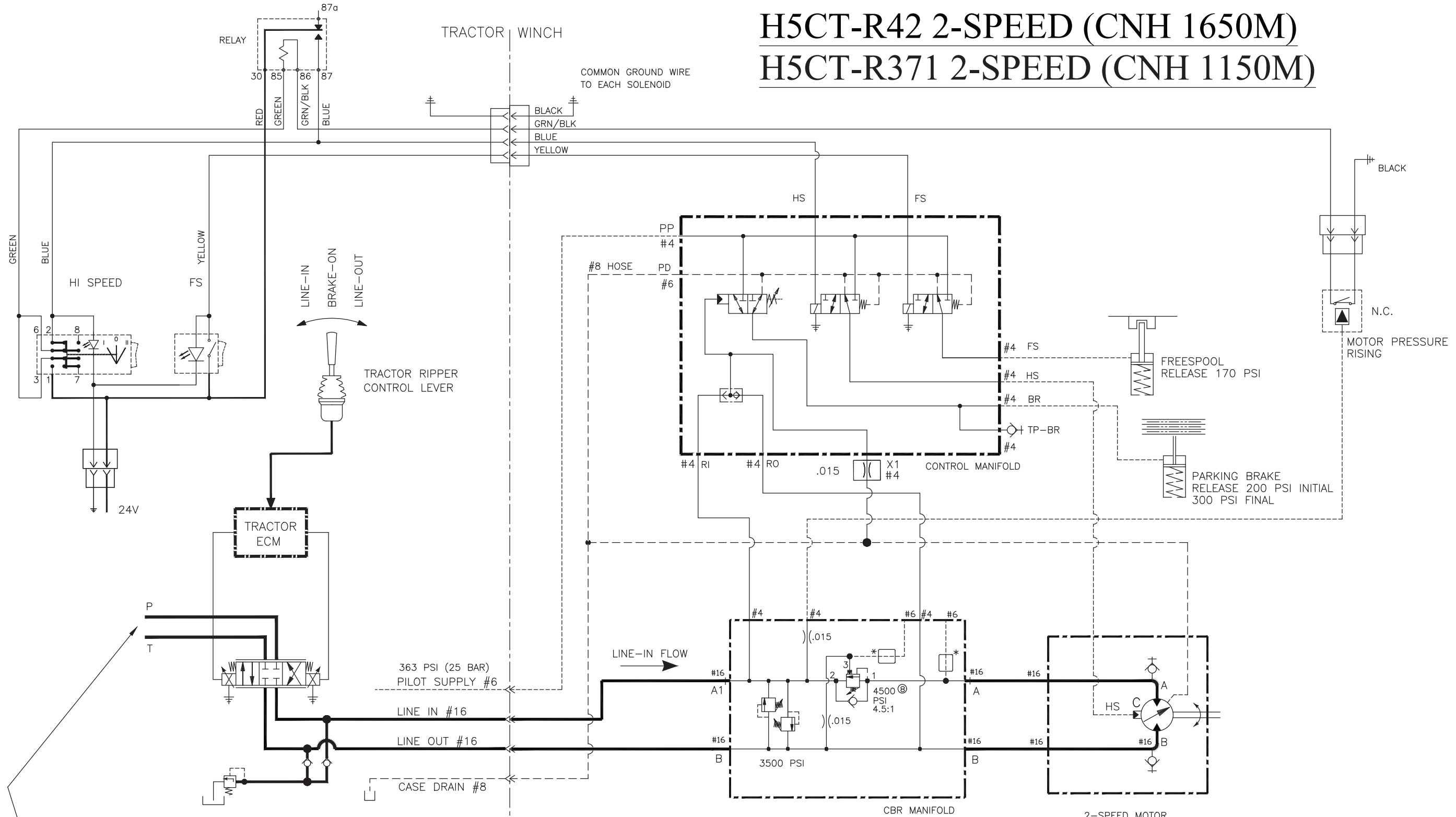
NOTES:

1. DETAIL FOR COILS. ALL EQUIPPED WITH TRANSIENT VOLTAGE SUPPRESSOR



Figure 1-34 H5C Hydraulic/Electrical Schematic, Liebherr PR716 (L39)

H5CT-R42 2-SPEED (CNH 1650M) H5CT-R371 2-SPEED (CNH 1150M)



R42:
3000 PSI (207 BAR)
48 GPM (182 L/MIN)

R371:
3000 PSI (207 BAR)
34 GPM (130 L/MIN) LINE-IN
28 GPM (105 L/MIN) LINE-OUT

- NOTES:
1. DETAIL FOR COILS. ALL EQUIPPED WITH TRANSIENT VOLTAGE SUPPRESSOR

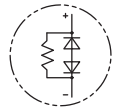


Figure 1-35 H5C Hydraulic/Electrical Schematic, Case 1650M (R42) & 1150M (R371)

H5CT-Y46 2-SPEED (TCi 920) WITH DRAG-BRAKE

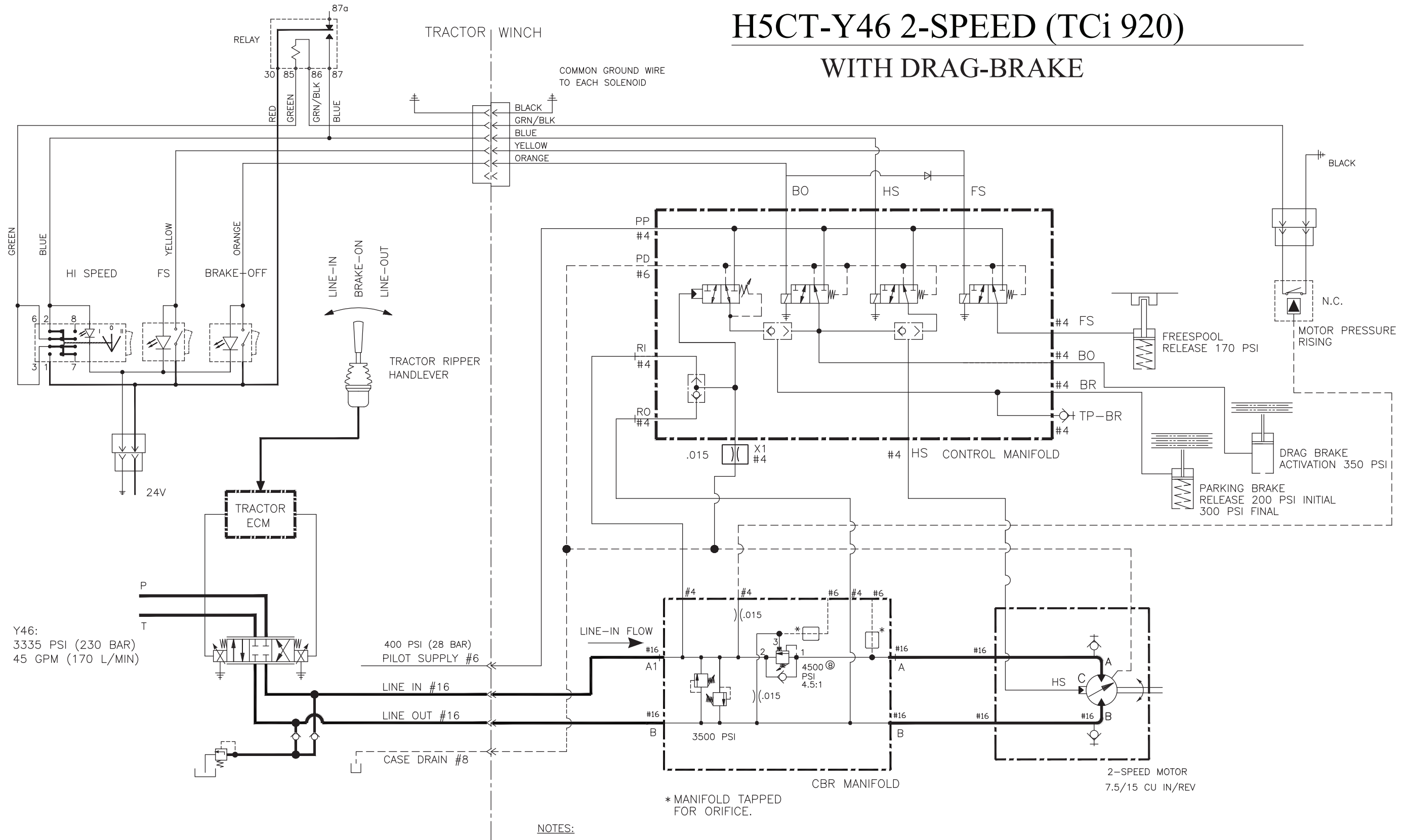


Figure 1-36 H5C Hydraulic/Electrical Schematic, TCi 920 (Y46F)

Troubleshooting

General

Winch problems fall into one of three categories: control system, hydraulic system or mechanical system. Follow the troubleshooting steps below to isolate the problem area.

1. Be sure the tractor hydraulic system is working properly. Verify that other implements, such as blade functions, are operating properly.
2. Make sure the winch electrical system is functioning properly.
3. Check winch hydraulic pressures. See Service section of this manual to perform Hydraulic System Pressure Checks.
4. Inspect the winch gear train for mechanical problems.

Mechanical/Hydraulic Troubleshooting

For proper hydraulic troubleshooting, the winch oil operating temperature should not exceed 180°F (82°C). Oil reservoir temperature is monitored at the dozer.

NOTE: Please refer to the Safety Summary before performing any troubleshooting or maintenance on the winch.

PROBLEM	POSSIBLE CAUSE	CORRECTION ACTION
Winch Does Not Operate with the Tractor Running		
Hydraulic power not being supplied to winch.	Tractor work equipment lever is in locked position.	Unlock tractor work equipment lever.
	Improper winch hose routing.	Verify hose connections are in accordance with hydraulic schematic and installation instructions for specific application.
	Low oil.	Check for proper oil level.
No pilot pressure (PS).	Tractor work equipment lever is locked.	Unlock tractor work equipment lever.
	Improper winch hose routing.	Verify hose connections are in accordance with hydraulic schematic and installation instructions for specific application.
Low pilot pressure (PS).	Improper tractor pilot supply setting or malfunction.	Refer to tractor pilot system troubleshooting.
Brake not releasing.	No or low brake release pressure.	Check pilot pressure. Check hoses for leaks.
	Brake valve out of adjustment or damaged.	Perform brake valve pressure checks and adjust as specified. Remove valve and inspect for debris or damage. Replace valve as necessary.
	Improper winch hose routing.	Verify hose connections are in accordance with hydraulic schematic and installation instructions for specific application.
	Brake mechanical damage.	Repair or replace brake.

Figure 2-1 Mechanical/Hydraulic Troubleshooting Chart -1

PROBLEM	POSSIBLE CAUSE	CORRECTION ACTION
Winch Operates But Exhibits The Following Problems		
Winch operates in LINE-IN only.	Brake shuttle stuck.	Check for debris.
	Counterbalance valve pilot signal blocked or connected to drain.	Check for plugged control manifold passage or missing manifold plug.
	Counterbalance valve damaged or set incorrectly.	Adjust or replace counterbalance valve.
	Malfunction in the ripper control circuit.	Troubleshoot circuit per tractor service manual.
Winch operates in LINE-OUT only.	Brake shuttle stuck.	Check for debris.
	Malfunction in the ripper control circuit.	Troubleshoot circuit per tractor service manual.
Winch will not generate sufficient line pull.	Tractor implement pump relief set too low.	Check tractor hydraulic system settings.
	Worn or damaged components in the gear train.	Visually inspect to identify damaged components. Repair and replace as necessary.
	Brake not releasing due to insufficient brake release pressure or leak in brake.	Check that brake release pilot pressure is more than 200 psi in LINE-IN and LINE-OUT functions. If pilot pressure is too low, check for leaks, faulty control lever, or insufficient pilot supply pressure. See Step By Step Pump and Controller Troubleshooting section in this chapter. If brake is leaking, repair as needed.
	Brake shuttle valve stuck.	Clean or replace as necessary.
	Leak in hydraulic system other than brake assembly.	Plug brake line and check that pressure at motor ports A & B (See Hydraulic System Pressure Check Tables).
	Leak in motor speed spool relief cartridge (HI-SPEED only).	Check that the pressures at motor test ports A & B are sufficient for operating the winch in LINE-IN/OUT with the brake line plugged. If the pressure is low and registered simultaneously at A and B, leakage is occurring past the relief valve. Remove and repair the valve.
	Clogged filter.	Tractor filter indicator light will illuminate if filter is clogged. Replace filter. Refer to tractor specifications.
	Wrong oil.	Use correct oil grade; refer to tractor oil specifications.
	Low oil level in reservoir.	Add oil; refer to tractor oil specifications.
	Damaged freespool components may be causing winch to be stuck in FREESPOOL .	Inspect freespool shaft for wear or damage, repair or replace as necessary.
	Drag brake piston stuck.	Remove drag brake cover to determine if piston is stuck and not releasing the drag brake clutch.
Motor damaged.	Repair or replace motor.	

Figure 2-1 Mechanical/Hydraulic Troubleshooting Chart - 2

PROBLEM	POSSIBLE CAUSE	CORRECTION ACTION
Winch Operates But Exhibits The Following Problems		
Winch gets very hot.	Low oil level.	Add oil; refer to tractor oil specifications.
	Improper oil viscosity.	Use correct oil grade; refer to tractor oil specifications.
	Winch coated with dirt.	Clean winch.
	Clogged filter or strainer.	Replace tractor filter.
	Clogged cooler.	Clean cooler.
Operation is rough.	Low oil level.	Add oil; refer to tractor oil specifications.
	Low pilot pressure.	Refer to tractor pilot system troubleshooting.
	Wire rope jumps layers on drum.	Spool wire rope more evenly.
	Motor hunting between high and low speed.	Clean or replace high speed component.
Operation is noisy (NOTE: motor is significantly noisier in HI-SPEED mode).	Air in the hydraulic oil (indicated by foaming or milky-colored oil).	Inspect for leaks and other sources of air induction.
	Incorrect oil used.	Drain reservoir and re-fill with correct oil; refer to tractor oil specifications.
	Motor damaged.	Some noise is normal. However, excessive clattering could indicate damage. Inspect pump and motor thoroughly.
	Gear or bearing damage.	Visually inspect and repair as needed.
Drum continues to rotate after lever is returned to BRAKE-ON .	Counterbalance valve stuck open.	Repair or replace valve.
	Direction spool not shifting to centered position.	Direction spool sticking. Clean or replace. Control lever valve plunger sticking. Repair.
	Brake not engaged or worn.	Repair brake.
Oil level too high in gear-side cavity.	Too much oil added.	Drain excessive oil. Check level to "LEVEL" plug on winch case.
	Oil leaking from hydraulic supply into gear-side cavity.	Locate leak. Repair or replace faulty component.
	Drag brake housing leaking.	Ensure that drag brake seals are intact, including shaft seal, fitting o-rings, and the drag brake housing gasket.

Figure 2-1 Mechanical/Hydraulic Troubleshooting Chart - 3

PROBLEM	POSSIBLE CAUSE	CORRECTION ACTION
Winch Operates But Exhibits The Following Problems		
No HI-SPEED mode	HI-SPEED switch malfunction.	Replace switch.
	Wire harness.	Check connections and continuity or wire damage - repair or replace harness.
	Solenoid malfunction.	Check solenoid coil resistance and replace if measurement is not between 46-51 Ohms.
	Improper hose connection.	Inspect hydraulic lines and condition.
	Motor servo problem.	Contact Allied Service Department.
	2-speed spool in motor stuck.	Clean and/or repair 2-speed spool.
	2-speed pressure switch malfunctioning (normally closed.)	Repair or replace 2-speed pressure switch.
	2-speed relay malfunctioning.	Repair or replace relay.
	2-speed solenoid is not energized.	Repair power supply or replace coil and/or solenoid.
Winch stalls during operation.	Insufficient hydraulic pressure supplied by dozer.	Check dozer supply pressure (see Section 3). If incorrect, contact Allied Service Department.
FREESPOOL will not function or is difficult to engage.	FREESPOOL shifter fork or collar stuck.	Remove covers and inspect shifter fork & collar with switch in FREESPOOL position. Repair parts if damaged.
	Leakage at hydraulic connection or FREESPOOL shaft.	Remove covers and inspect shifter fork with switch in FREESPOOL position. Replace seals if leaking.
	Insufficient control pressure from tractor pilot supply.	1. Measure control pressure at brake (BR) port and FREESPOOL (FS) hose (refer to Section 3). 2. Check for leaks at hydraulic connections.
	FREESPOOL solenoid is not energized.	Repair power supply or replace coil and/or solenoid.
	Load on wire rope.	Move lever to LINE-OUT to release load.
Lever does not automatically return to BRAKE-ON position.	1. Plunger seal sticking in lever. 2. Spring in pilot controller unit broken.	Remove and inspect pilot controller unit on control lever assembly. Replace worn parts or entire assembly as necessary.
Winch does not respond to control lever movement.	1. Leak in the pilot controller unit on control lever assembly. 2. Control valve seized or blocked.	Check for leaks in control lever assembly and replace if necessary.
	Leak in hydraulic system, or loose hydraulic connections.	Visually inspect winch for leaks, and ensure hydraulic connections are secure.

Figure 2-1 Mechanical/Hydraulic Troubleshooting Chart - 4

PROBLEM	POSSIBLE CAUSE	CORRECTION ACTION
Winch Operates But Exhibits The Following Problems		
Line speed is abnormally slow for LINE-IN , LINE-OUT or both.	1. Poor pressure signal. 2. Leak in the pilot controller unit in the control lever assembly.	Visually inspect to check for wear on control lever assembly. Check for leaks in pilot controller unit and replace if necessary.
	Leak in hydraulic system, or loose hydraulic connections.	Visually inspect winch for leaks, and ensure hydraulic connections are secure.
Lever handle turns.	Handle parts loose.	Tighten all lever handle parts.
LEDs in switch panel do not illuminate.	Polarity backward.	Reverse plug connection.
	Faulty LED.	Replace LED.
Drag brake not holding.	Worn clutch plates.	Replace clutch plates in drag brake housing.
	Worn piston seals.	Remove piston and replace O-rings.
	Drag brake has no pressure.	Check pressure going to drag brake.
Check drag brake solenoid actuation.		

Figure 2-1 Mechanical/Hydraulic Troubleshooting Chart - 5

Notes



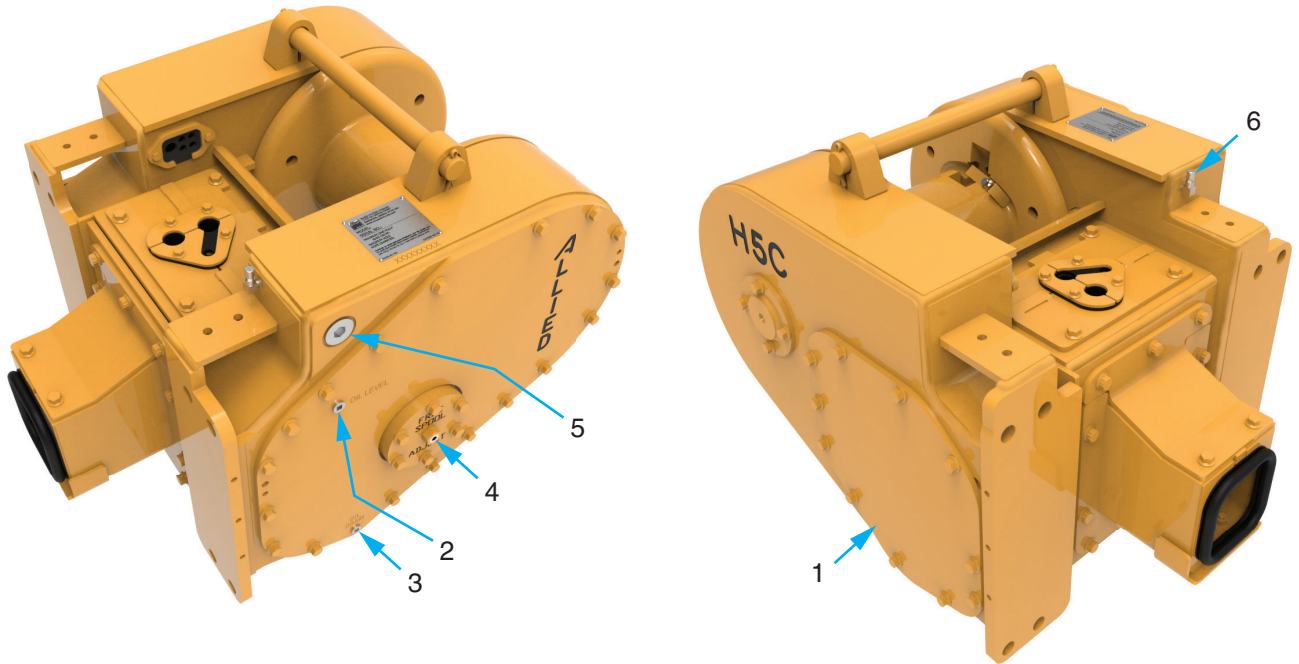
Service

General

This section provides the instructions for performing maintenance and making checks and adjustments. Standard shop tools are used in doing the work described in this section.

Maintenance

The Maintenance Schedule is a program that includes periodic inspection and lubrication. Use the operating time on the hour meter of the dozer to determine the maintenance time for the winch.



- | | |
|--|------------------------------|
| 1. Access Cover for Motor and Winch Hydraulics | 4. Freespool Drag Adjustment |
| 2. Oil Level Check Plug | 5. Oil Fill Plug |
| 3. Oil Drain Plug | 6. Breather |

Figure 3-1 H5C Winch Maintenance Points

INTERVAL	PROCEDURE OR QUANTITY	SPECIFICATION
50 hours or weekly	Check oil level at plug (item 2). Add oil as necessary through fill plug (item 5). Do not operate dozer when checking the oil level.	See Oil Specifications in Section 1.
	Clean the breather (item 6).	Remove debris around breather. Clean the breather with solvent if necessary.
	Lubricate the rollers on the integral arch or fairlead assembly, if the winch is so equipped.	Use multi-purpose grease with 2-4% molybdenum disulfide.
2000 hours or every 12 months	Change the gear oil. Drain oil from plug (item 3). Add oil through fill plug (item 5). Check the oil level at oil level check plug (item 2).	See Oil Specifications and Oil Capacity in Section 1.

Table 3-1 H5C Winch Maintenance Schedule

Checks Before Operation

Check that the wire rope and hook are not worn or damaged beyond serviceable condition. Check that the periodic inspection and maintenance have been done at the recommended operating hours. See Table 3-1, Maintenance Schedule.

Checks During Operation

The Troubleshooting Charts in Section 2 can be used by the operator to identify a problem with the winch operation. A trained service person is needed for additional troubleshooting and repair that requires disassembly of parts of the winch.

FREESPOOL Drag Adjustment

(See Figure 3-2)

The preload on the bearings of the intermediate shaft controls the resistance to rotation of the drum during **FREESPOOL** operation. The resistance to rotation is correct when the drum can be rotated by hand, but will not rotate more than one-half revolution after the hand is removed.

An adjusting setscrew is located in the center of the cover for the intermediate shaft. This screw can be tightened or loosened to adjust the preload on the intermediate shaft. The jam nut will maintain the **FREESPOOL** setting. This adjustment is normally only necessary if the winch has had an overhaul.

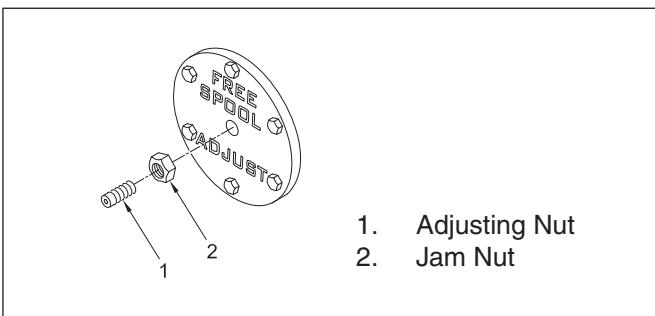


Figure 3-2 Freespool Adjustments

Hydraulic System Pressure Checks

The hydraulic oil and filter(s) should be maintained as indicated in the dozer Service Manual. If any problems are found, they should be corrected before operating the winch.

Preparation

1. These tests should be performed with a bare drum (no wire rope) since the drum will rotate during the tests.

 **WARNING**

Always wear gloves when handling wire rope.

 **WARNING**

Dozer engine must be shut OFF before disconnecting drum wire rope. Be careful when you remove the wire rope from the drum. The end of the wire rope can move like a compressed spring, causing an injury when the ferrule is released from the drum.

2. Start the engine and place the winch in **LINE-OUT** to raise the oil temperature. Another way to elevate the reservoir temperature is to hold the dozer blade over relief. The oil temperature in the winch or dozer reservoir must be at least 70°F (20°C).
3. Remove any dirt from the right side of the winch. Remove access plate.
4. Stabilize engine speed at high free idle for all tests.
5. Leave test plugs securely installed unless testing that port.
6. After completing all pressure checks and making the necessary adjustments ensure that all plugs and hoses are securely installed.
7. Install side covers and tighten capscrews.

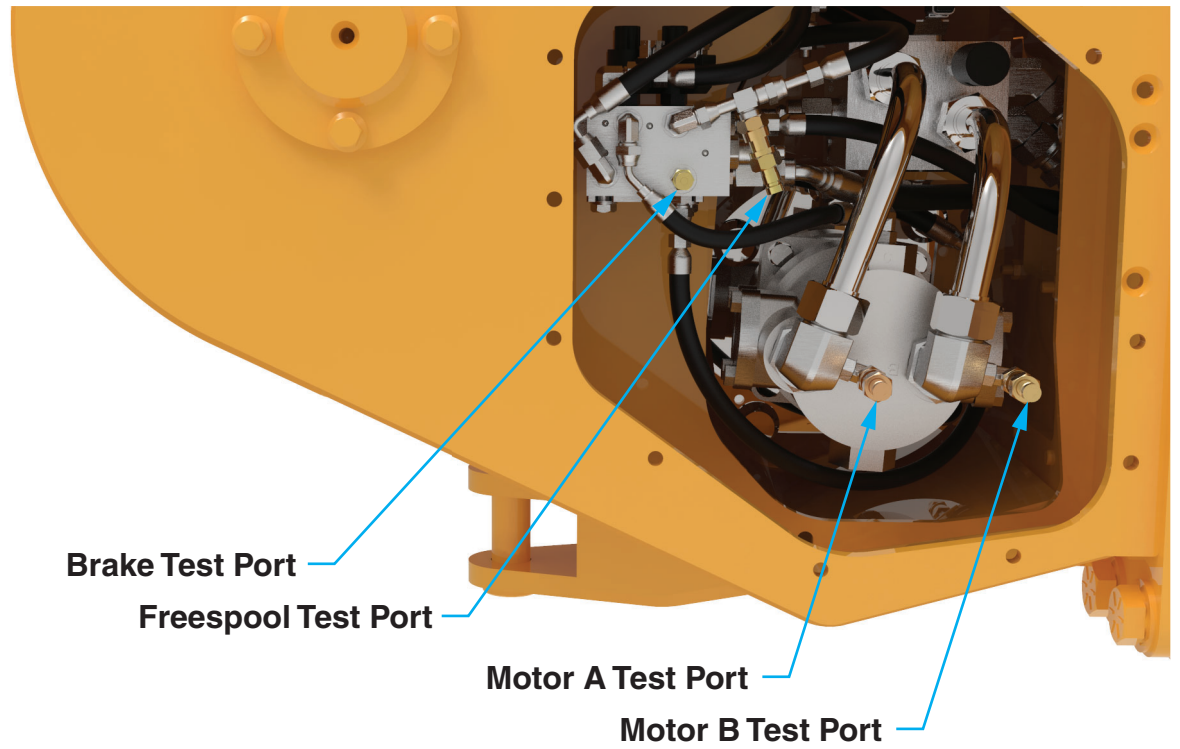


Figure 3-3 Hydraulic Pressure Test Ports (Units without optional DRAG-BRAKE)

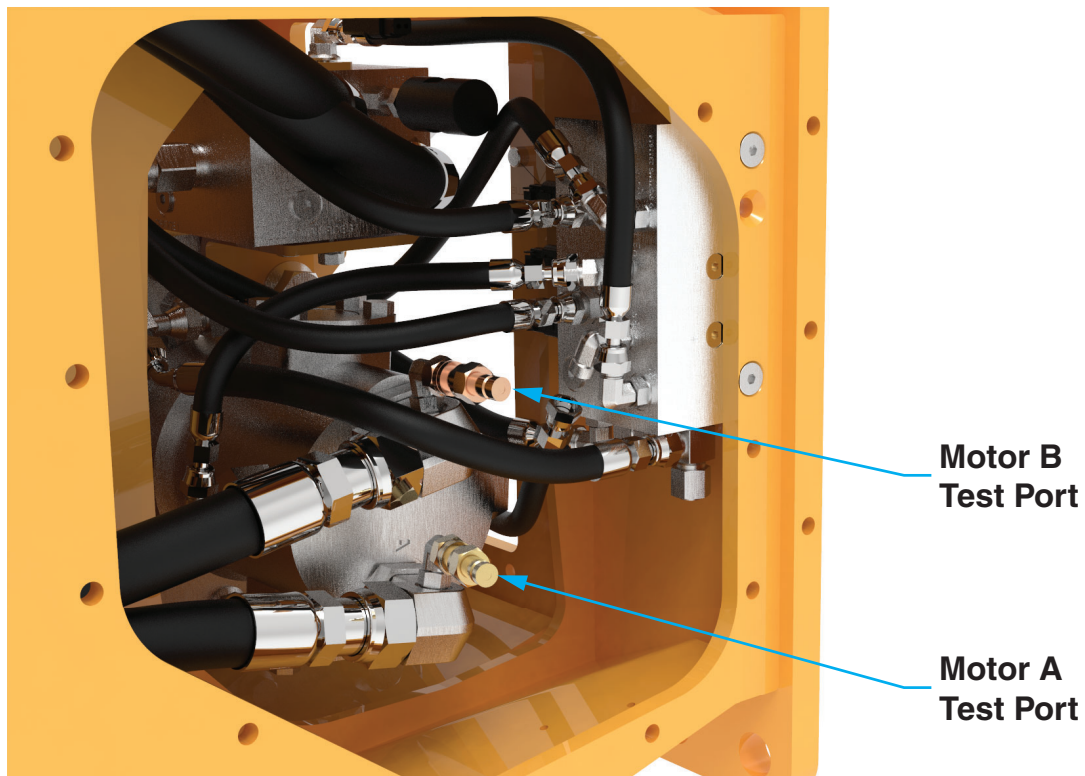
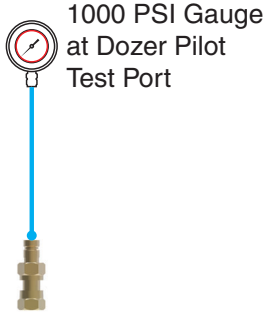


Figure 3-4 Hydraulic Pressure Test Ports (Units with optional DRAG-BRAKE)

Pilot Supply Pressure Check

All installations



See dozer service manual for pilot test port location.

Figure 3-5 Test Equipment Setup

Test Equipment:

- (1) 1,000 psi (6,895 kPa) Gauge

Connect pressure gauge to test port:

- Dozer pilot test port

General

Adequate standby pilot supply is required for both dozer and winch functions.

NOTICE

The values in Table 3-2 are based on information available at time of publishing. Refer to the service/maintenance manual supplied with your dozer to verify the available pilot pressure.

Instructions

1. Shut engine off but turn dozer key switch back on to provide electrical power to the winch.
2. Move dozer work equipment lever to unlock position to enable winch.
3. Move control handle from **BRAKE-ON** to **LINE-IN** several times to de-energize the hydraulic system.
4. Move dozer work equipment lever to locked position.
5. Connect a 1000 psi gauge to the dozer pilot test port (see dozer Service Manual).
6. Start dozer and set to high-free idle.
7. Check that the pressure reading is within the range shown for your dozer in Table 3-2.

If the pressure is not as specified, check for:

1. Improper pilot supply valve setting or malfunction (See dozer Service Manual).
2. Pump pressure setting incorrect (See dozer Service Manual).
3. Leaking pressure hoses or fittings.
4. Correct pilot supply location from dozer.

Dozer	Pilot Pressure in PSI [kPa]
	Dozer Pilot Test Port
Komatsu D51-24 (K371)	300 - 400 [2,068 - 2,758]
CAT D6K2 T4F (C805)	400 - 435 [2,758 - 2,999]
CNH 1650M (R42)	350 - 370 [2,413 - 2,551]
CNH 1150M (R371)	
Liebherr PR716 (L39)	290 - 350 [1,999 - 2,413]
TCi 920 (Y46F)	350 - 400 [2,413 - 2,758]

Table 3-2 Hydraulic Pressure Readings

Motor Supply Pressure Check

All installations without optional **DRAG-BRAKE**

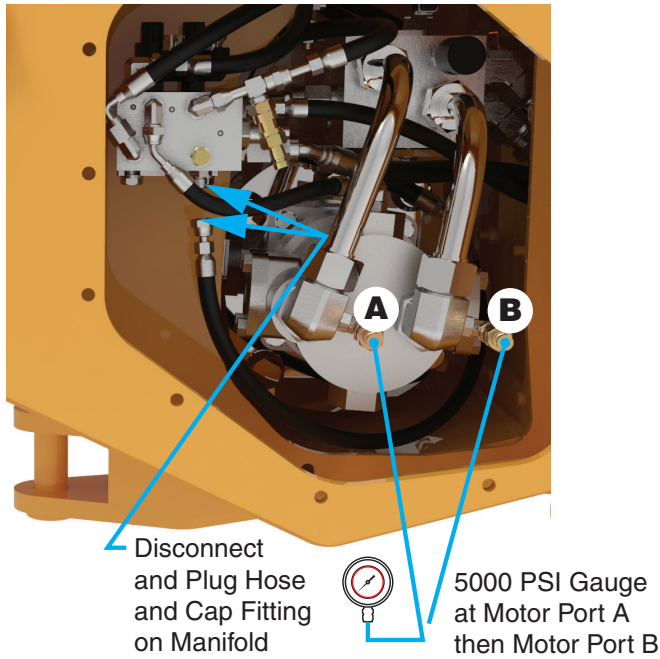


Figure 3-6 Test Equipment Setup

If the motor supply pressure is not as specified in Table 3-3, check for:

1. If pressure is too high, check dozer hydraulic system.
2. If it is too low, proceed with troubleshooting to identify other possible problems, including a possibly damaged motor or pump.

NOTICE

The values in Table 3-3 are based on information available at time of publishing. Refer to the service/maintenance manual supplied with your dozer to verify the available supply pressure.

Test Equipment:

- (1) 5,000 psi (34,474 kPa) Gauge

Connect pressure gauge to test ports:

- **Motor Port A**
- **Motor Port B**

General

This test ensures that the motor is receiving the intended hydraulic supply at both ports.

Instructions

1. With the engine shut off, connect a 5000 psi pressure gauge to Motor Port A.
2. Disconnect and plug the brake release hose at the control manifold, and cap the fitting. See Figure 3-6. This will lock the winch brake to build pressure in the motor.
3. Start dozer and set to high-free idle.
4. Check the pressure at Motor Port A while operating in **LINE-IN**. Check the pressure at Motor Port B while operating in **LINE-OUT**. See Table 3-3.
5. When motor supply pressure check is complete, remove gauge and reconnect brake release hose.

Full Supply Pressure in PSI [kPa]		
Dozer	Motor Port A	Motor Port B
Komatsu D51-24 (K371)	3,350 - 3,500 [23,097 - 24,132]	3,350 - 3,500 [23,097 - 24,132]
CAT D6K2 T4F (C805)	3,620 - 3,770 [24,959 - 25,993]	3,620 - 3,770 [24,959 - 25,993]
CNH 1650M (R42)	2,850 - 3,000 [19,650 - 20,684]	2,850 - 3,000 [19,650 - 20,684]
CNH 1150M (R371)	2,900 - 3,050 [19,995 - 21,029]	2,900 - 3,050 [19,995 - 21,029]
Liebherr PR716 (L39)	3,040 - 3,190 [20,960 - 21,994]	3,040 - 3,190 [20,960 - 21,994]

Table 3-3 Hydraulic Pressure Readings

Brake Pressure Check

All installations without optional **DRAG-BRAKE**

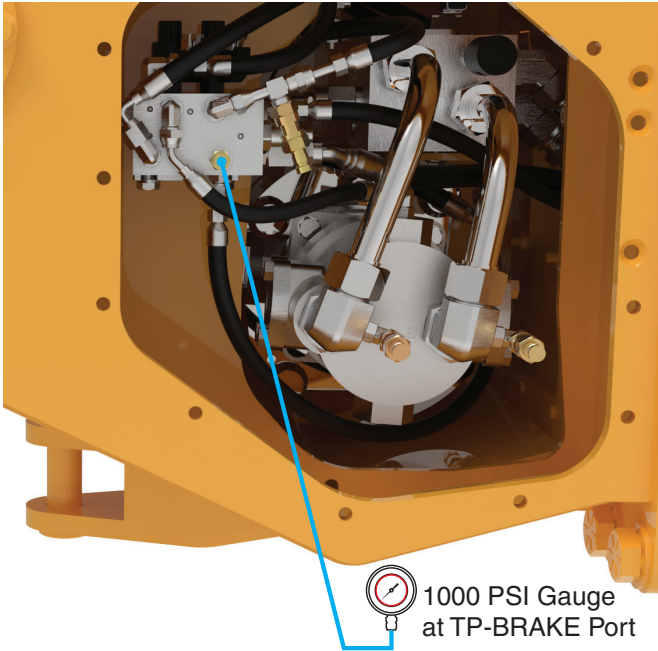


Figure 3-7 Test Equipment Setup

Instructions

1. With the engine shut off, connect a 1000 psi pressure gauge to the **TP-BRAKE** pressure test port on the control manifold.
2. Start dozer and set to high-free idle
3. Operate the winch in **LINE-IN** and **LINE-OUT**.
4. Check pressure. The pressure at this port should be equal to the pilot supply pressure from the dozer. The brake begins to release at 200 psi, and fully releases at 300 psi. Low pressure will result in premature wear of the friction discs and added heat generation.

If the brake pressure is not at least 300 psi, check for:

1. Improper pilot supply pressure.
2. Malfunctioning control lever; low **RI** and/or **RO** pressure.
3. Leaking pressure hoses or fittings.
4. Restriction in pressure hose or manifold port.

Test Equipment:

- (1) 1,000 psi (6,895 kPa) Gauge

Connect pressure gauge to test port:

- **TP-BRAKE**

Brake Valve Pressure Check and Adjustment

All installations without optional DRAG-BRAKE

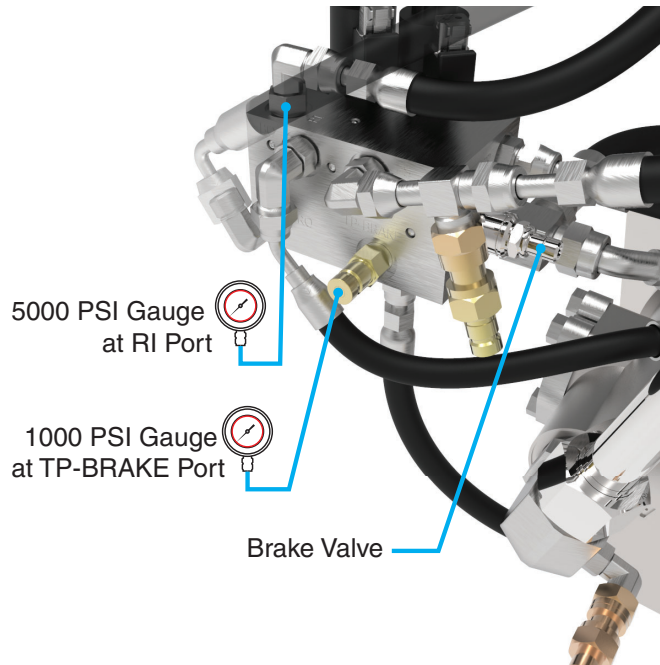


Figure 3-8 Test Equipment Setup

Test Equipment:

- (1) 1,000 psi (6,895 kPa) Gauge
- (1) 5,000 psi (34,474 kPa) Gauge

Connect pressure gauges to:

- **RI (Tee into existing line)**
- **TP-BRAKE test port**

Instructions

1. With the engine shut off, connect a 1000 psi pressure gauge to the **TP-BRAKE** pressure test port. Use a tee and fittings as available to connect a 5000 psi pressure gauge at the **RI** port on the control manifold.

NOTICE

Even though the pressure required for brake release at RI is low, the actual pressure sent to that port could be full supply pressure on some installations. Use a 5,000 psi gauge.

2. Start dozer and set to high-free idle.
3. Slowly meter the control lever into the **LINE-IN** position while monitoring both gauges.
4. **TP-BRAKE** pressure will jump to full pilot supply pressure when **RI** reaches the pilot setting of the brake valve.

5. Check pressure as indicated in Table 3-4. The brake valve sets the overlap between the hydraulic motor drive and brake release.
6. A low setting on the brake release valve will release the brake before the motor begins driving. A high setting on the brake release valve will momentarily drive the motor against the brake before the brake releases.

Brake Valve Adjustment

1. Slowly meter the control lever into the **LINE-IN** position.
2. Measure pressure at **TP-BRAKE** and **RI** pressure test ports.
3. Loosen brake valve locknut. Turn adjusting capscrew **OUT** to decrease pressure and **IN** to increase pressure. Adjust pressures as shown in Table 3-4.

NOTICE

The values in Table 3-4 are based on information available at time of publishing. Refer to the service/maintenance manual supplied with your dozer to verify the available pilot pressure.

Dozer	Pressure in PSI [kPa]	
	RI BRAKE RELEASE PRESSURE	TP-BRAKE PILOT PRESSURE
Komatsu D51-24 (K371)	100-120 [689-827]	300 - 400 [2,068 - 2,758]
CAT D6K2 T4F (C805)	80-100 [552-689]	400 - 435 [2,758 - 2,999]
CNH 1650M (R42)	80-100 [552-689]	350 - 370 [2,413 - 2,551]
CNH 1150M (R371)	80-100 [552-689]	
Liebherr PR716 (L39)	100-120 [689-827]	290 - 350 [1,999 - 2,413]

Table 3-4 Hydraulic Pressure Readings

FREESPOOL Pressure Check

All installations with optional **DRAG-BRAKE**

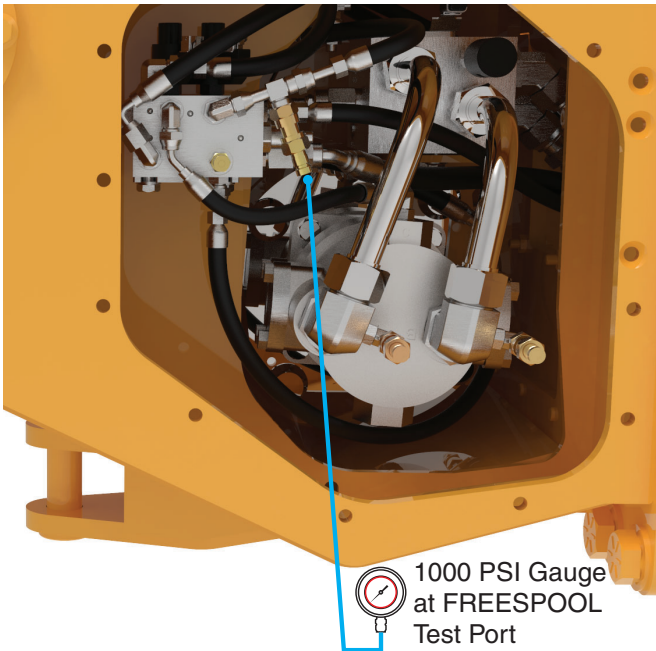


Figure 3-9 Test Equipment Setup

Instructions

1. With the engine shut off, connect a 1000 psi pressure gauge to the **FREESPOOL** pressure test port.
2. Start dozer and set to high-free idle
3. Measure pressure with the **FREESPOOL** switch activated.
4. Check pressure. The pressure at this port should be equal to the pilot supply pressure from the dozer. **FREESPOOL** requires 170 psi to release. Low pressure will not allow for full disengagement of gears for **FREESPOOL** function.

If pressure is not at least 170 psi, check for:

1. Improper pilot supply pressure.
2. Malfunctioning solenoid valve.
3. Leaking pressure hoses or fittings.
4. Restriction in pressure hose or manifold port.
5. Leaking in gear side of winch. Watch oil level at the fill level plug to determine if there is leaking in gear side.

Test Equipment:

- (1) 1,000 psi (6,895 kPa) Gauges

Connect pressure gauges to test ports:

- **FREESPOOL**

LINE-IN Pressure Check

All installations without optional DRAG-BRAKE

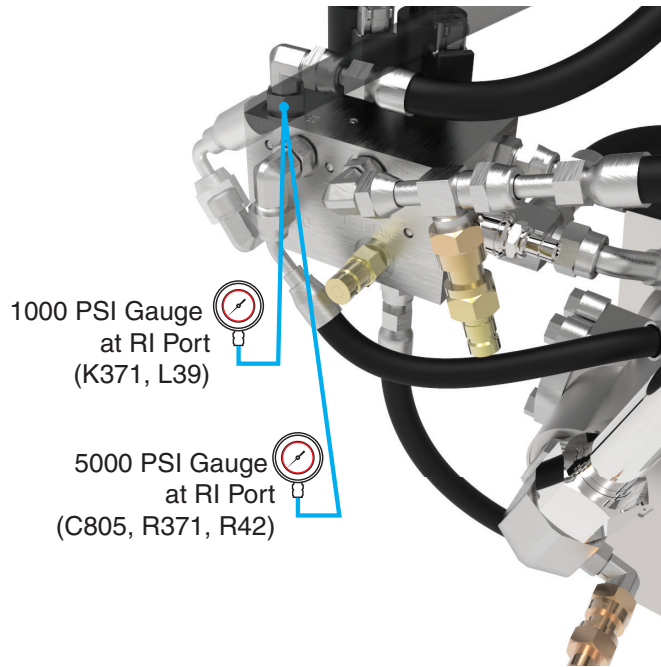


Figure 3-10 Test Equipment Setup

Test Equipment:

- (1) 1,000 psi (6,895 kPa) Gauge (K371, L39)
- (1) 5,000 psi (34,474 kPa) Gauge (C805, R371, R42)

Connect pressure gauge to port:

- **RI**

NOTICE

The values in Table 3-5 are based on information available at time of publishing. Refer to the service/maintenance manual supplied with your dozer to verify the available pilot pressure.

Instructions

1. With the engine shut off, connect pressure gauge in line on the RI hose at the control manifold.
2. Start dozer and set to high-free idle.
3. Measure pressure with the control lever in the LINE-IN position.
4. Pressure should be as specified in Table 3-5.

If the LINE-IN pressure is not as specified in Table 3-5, check for:

1. Improper pilot supply pressure.
2. Malfunctioning control lever.
3. Leaking pressure hoses or fittings.
4. Restriction in pressure hose or manifold port.

Dozer	Pressure in PSI [kPa]
	Test Port RI
Komatsu D51-24 (K371)	300 - 400 [2,068 - 2,758]
CAT D6K2 T4F (C805)	3,620 - 3,770 [24,959 - 25,993]
CNH 1650M (R42)	2,850 - 3,000 [19,650 - 20,684]
CNH 1150M (R371)	2,900 - 3,050 [19,995 - 21,029]
Liebherr PR716 (L39)	290 - 350 [1,999 - 2,413]

Table 3-5 Hydraulic Pressure Readings

LINE-OUT Pressure Check

All installations without optional DRAG-BRAKE

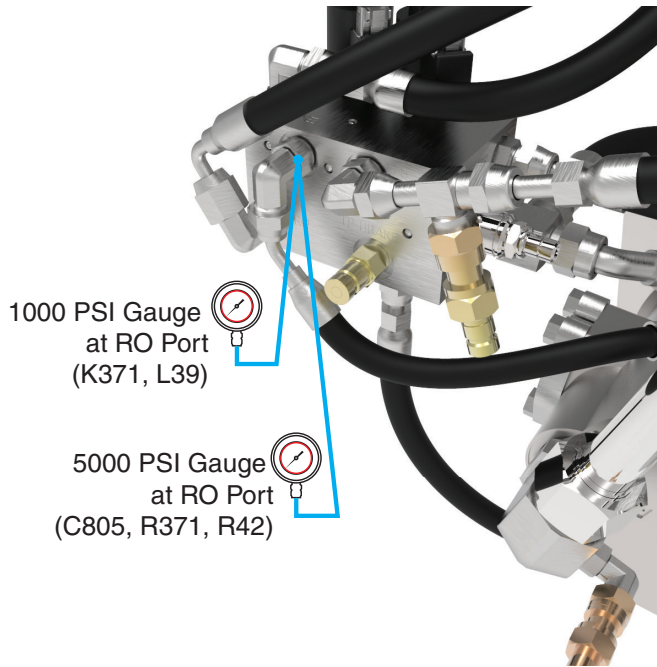


Figure 3-11 Test Equipment Setup

Instructions

1. With the engine shut off, connect pressure gauge in line on the RO hose at the control manifold.
2. Start dozer and set to high-free idle.
3. Measure pressure with the control lever in the LINE-OUT position.
4. Pressure should be as specified in Table 3-6.

If the LINE-OUT pressure is not as specified in Table 3-6, check for:

1. Improper pilot supply pressure.
2. Malfunctioning control lever.
3. Leaking pressure hoses or fittings.
4. Restriction in pressure hose or manifold port.

Test Equipment:

- (1) 1,000 psi (6,895 kPa) Gauge (K371, L39)
- (1) 5,000 psi (34,474 kPa) Gauge (C805, R371, R42)

Connect pressure gauge to test port:

- RO

NOTICE

The values in Table 3-6 are based on information available at time of publishing. Refer to the service/maintenance manual supplied with your dozer to verify the available pilot pressure.

Dozer	Pilot Pressure in PSI [kPa]
	Test Port RO
Komatsu D51-24 (K371)	300 - 400 [2,068 - 2,758]
CAT D6K2 T4F (C805)	3,620 - 3,770 [24,959 - 25,993]
CNH 1650M (R42)	2,850 - 3,000 [19,650 - 20,684]
CNH 1150M (R371)	2,900 - 3,050 [19,995 - 21,029]
Liebherr PR716 (L39)	290 - 350 [1,999 - 2,413]

Table 3-6 Pilot Pressure Readings

Motor Supply Pressure Check

All installations with optional DRAG-BRAKE

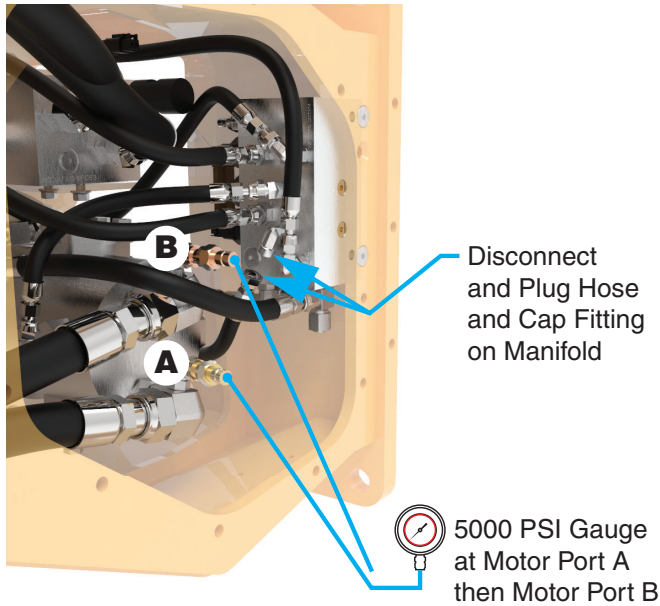


Figure 3-12 Test Equipment Setup

Test Equipment:

- (1) 5,000 psi (34,474 kPa) Gauge

Connect pressure gauge to test ports:

- **Motor Port A**
- **Motor Port B**

General

This test ensures that the motor is receiving the intended hydraulic supply at both ports.

Instructions

1. With the engine shut off, connect a 5000 psi pressure gauge to Motor Port A.
2. Disconnect and plug the brake release hose at the control manifold, and cap the fitting. See Figure 3-12. This will lock the winch brake to build pressure in the motor.
3. Start dozer and set to high-free idle.
4. Check the pressure at Motor Port A while operating in **LINE-IN**. Check the pressure at Motor Port B while operating in **LINE-OUT**. See Table 3-7.
5. When motor supply pressure check is complete, remove gauge and reconnect brake release hose.

If the motor supply pressure is not as specified in Table 3-7, check for:

1. If pressure is too high, check dozer hydraulic system.
2. If it is too low, proceed with troubleshooting to identify other possible problems, including a possibly damaged motor or pump.

NOTICE

The values in Table 3-7 are based on information available at time of publishing. Refer to the service/maintenance manual supplied with your dozer to verify the available supply pressure.

Full Supply Pressure in PSI [kPa]		
Dozer	Motor Port A	Motor Port B
TCi 920 (Y46F)	3,185 - 3,335 [21,960 - 22,994]	3,185 - 3,335 [21,960 - 22,994]

Table 3-7 Hydraulic Pressure Readings

Brake Pressure Check

All installations with optional **DRAG-BRAKE**

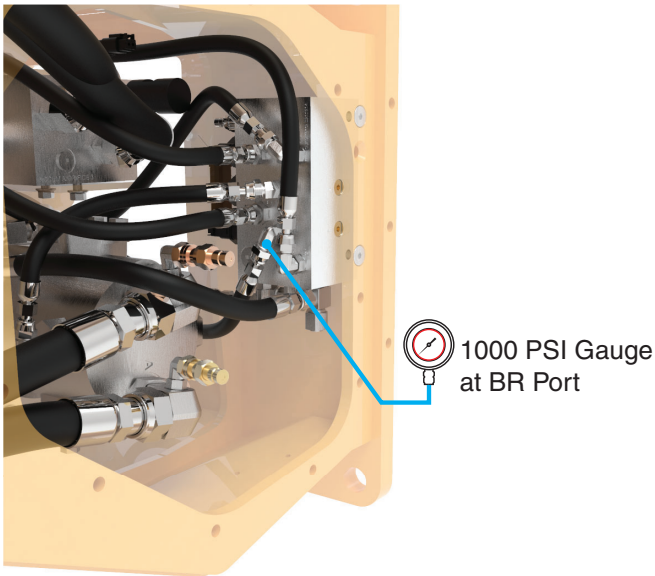


Figure 3-13 Test Equipment Setup

Instructions

1. With the engine shut off, connect a 1000 psi pressure gauge in line with the **BR** port on the control manifold.
2. Start dozer and set to high-free idle
3. Operate the winch in **LINE-IN** and **LINE-OUT**.
4. Check pressure. The pressure at this port should be equal to the pilot supply pressure from the dozer. The brake begins to release at 200 psi, and fully releases at 300 psi. Low pressure will result in premature wear of the friction discs and added heat generation.

If the brake pressure is not at least 300 psi, check for:

1. Improper pilot supply pressure.
2. Malfunctioning control lever; low **RI** and/or **RO** pressure.
3. Leaking pressure hoses or fittings.
4. Restriction in pressure hose or manifold port.

Test Equipment:

- (1) 1,000 psi (6,895 kPa) Gauge

Connect pressure gauge to port:

- **BR**

Brake Valve Pressure Check and Adjustment

All installations with optional DRAG-BRAKE

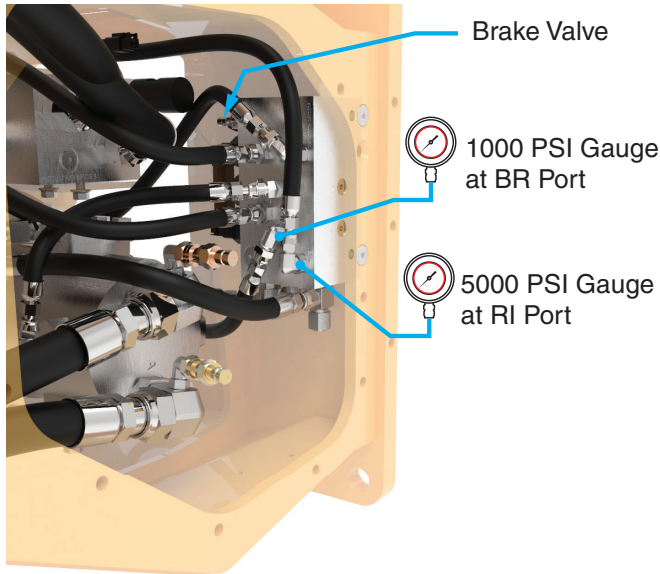


Figure 3-14 Test Equipment Setup

Test Equipment:

- (1) 1,000 psi (6,895 kPa) Gauge
- (1) 5,000 psi (34,474 kPa) Gauge

Connect pressure gauges to:

- **RI (Tee into existing line)**
- **BR (Tee into existing line)**

Instructions

1. Use tees and fittings as available to connect 1000 psi pressure gauges at both the **RI** and **BR** ports on the control manifold.

NOTICE

Even though the pressure required for brake release at RI is low, the actual pressure sent to that port could be full supply pressure. Use a 5,000 psi gauge.

2. Start dozer and set to high-free idle.
3. Slowly meter the control lever into the **LINE-IN** position while monitoring both gauges.
4. **BR** pressure will jump to full pilot supply pressure when **RI** reaches the pilot setting of the brake valve.

5. Check pressure as indicated in Table 3-8. The brake valve sets the overlap between the hydraulic motor drive and brake release.
6. A low setting on the brake release valve will release the brake before the motor begins driving. A high setting on the brake release valve will momentarily drive the motor against the brake before the brake releases.

Brake Valve Adjustment

1. Slowly meter the control lever into the **LINE-IN** position.
2. Measure pressure at **BR** and **RI** pressure test ports.
3. Loosen brake valve locknut. Turn adjusting capscrew **OUT** to decrease pressure and **IN** to increase pressure. Adjust pressures as shown in Table 3-8.

NOTICE

The values in Table 3-8 are based on information available at time of publishing. Refer to the service/maintenance manual supplied with your dozer to verify the available pilot pressure.

Dozer	Pressure in PSI [kPa]	
	RI BRAKE RELEASE PRESSURE	TP-BRAKE PILOT PRESSURE
TCi 920 (Y46F)	80-100 [552-689]	350 - 400 [2,413 - 2,758]

Table 3-8 Hydraulic Pressure Readings

FREESPOOL Pressure Check

All installations with optional **DRAG-BRAKE**

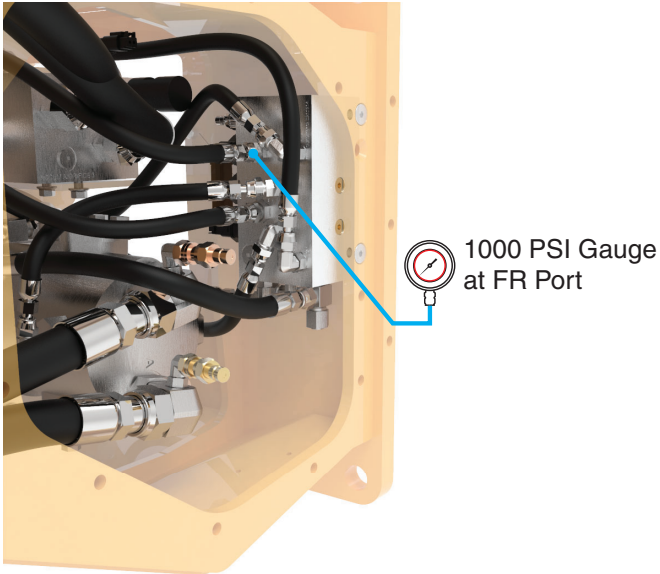


Figure 3-15 Test Equipment Setup

Instructions

1. With the engine shut off, use tees and fittings as available to connect a 1000 psi pressure gauge to the **FR** port.
2. Start dozer and set to high-free idle
3. Measure pressure with the **FREESPOOL** switch activated.
4. Check pressure. The pressure at this port should be equal to the pilot supply pressure from the dozer. **FREESPOOL** requires 170 psi to release. Low pressure will not allow for full disengagement of gears for **FREESPOOL** function.

If pressure is not at least 170 psi, check for:

1. Improper pilot supply pressure.
2. Malfunctioning solenoid valve.
3. Leaking pressure hoses or fittings.
4. Restriction in pressure hose or manifold port.
5. Leaking in gear side of winch. Watch oil level at the fill level plug to determine if there is leaking in gear side.

Test Equipment:

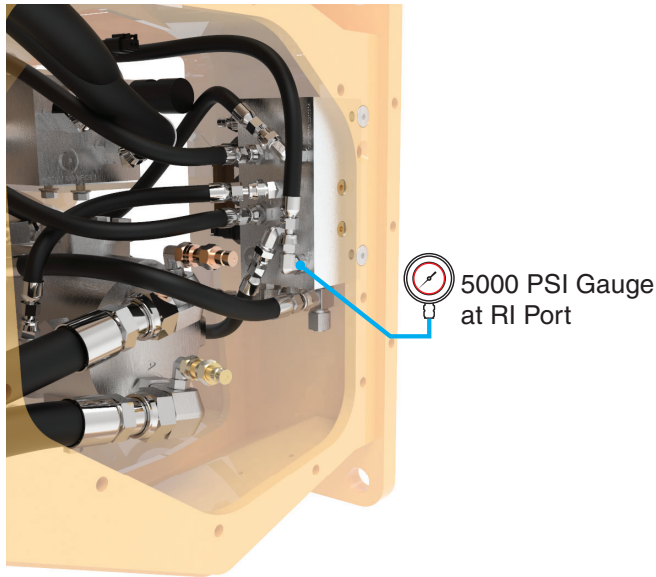
- (1) 1,000 psi (6,895 kPa) Gauges

Connect pressure gauges to port:

- **FR (Tee into existing line)**

LINE-IN Pressure Check

All installations with optional DRAG-BRAKE



Instructions

1. With the engine shut off, connect pressure gauge in line on the **RI** hose at the control manifold.
2. Start dozer and set to high-free idle.
3. Measure pressure with the control lever in the **LINE-IN** position.
4. Pressure should be as specified in Table 3-9.

If the **LINE-IN** pressure is not as specified in Table 3-9, check for:

1. Improper pilot supply pressure.
2. Malfunctioning control lever.
3. Leaking pressure hoses or fittings.
4. Restriction in pressure hose or manifold port.

Figure 3-16 Test Equipment Setup

Test Equipment:

- (1) 5,000 psi (34,474 kPa) Gauge

Connect pressure gauge to port:

- **RI (Tee into existing line)**

NOTICE

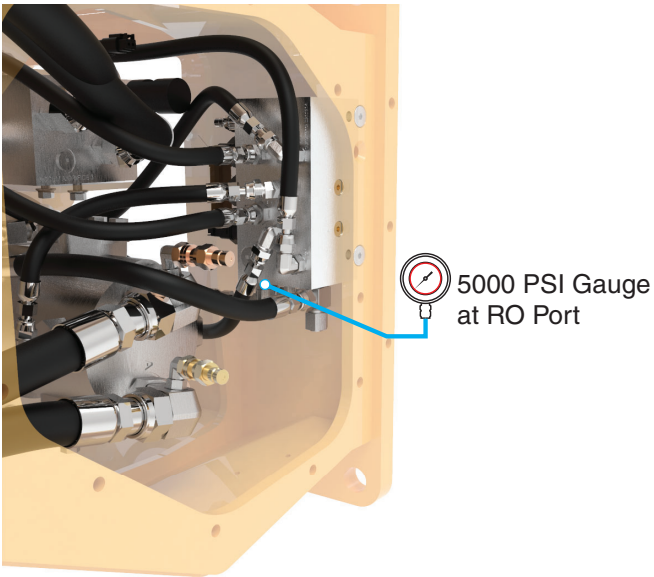
The values in Table 3-9 are based on information available at time of publishing. Refer to the service/maintenance manual supplied with your dozer to verify the available pilot pressure.

Pilot Pressure in PSI [kPa]	
Dozer	Test Port RI
TCi 920 (Y46F)	3,185 - 3,335 [21,960 - 22,994]

Table 3-9 Hydraulic Pressure Readings

LINE-OUT Pressure Check

All installations with optional DRAG-BRAKE



Instructions

1. With the engine shut off, connect pressure gauge in line on the **RO** hose at the control manifold.
2. Start dozer and set to high-free idle.
3. Measure pressure with the control lever in the **LINE-OUT** position.
4. Pressure should be as specified in Table 3-10.

If the **LINE-OUT** pressure is not as specified in Table 3-10, check for:

1. Improper pilot supply pressure.
2. Malfunctioning control lever.
3. Leaking pressure hoses or fittings.
4. Restriction in pressure hose or manifold port.

Figure 3-17 Test Equipment Setup

Test Equipment:

- (1) 5,000 psi (34,474 kPa) Gauge

Connect pressure gauge to port:

- **RO (Tee into existing line)**

NOTICE

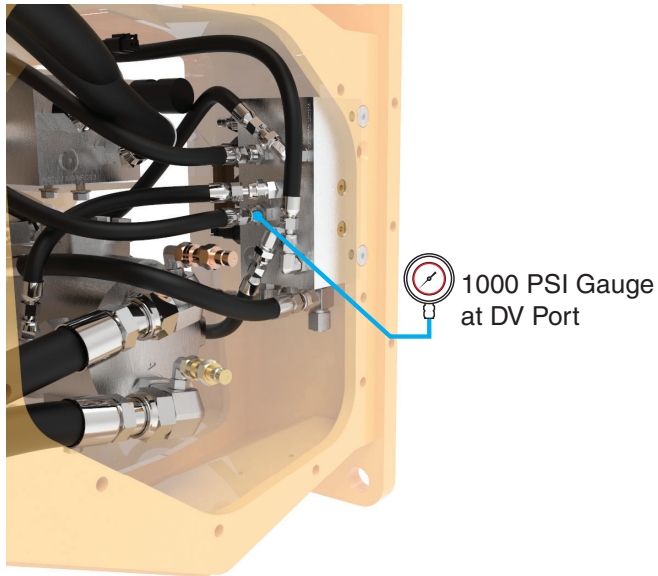
The values in Table 3-10 are based on information available at time of publishing. Refer to the service/maintenance manual supplied with your dozer to verify the available pilot pressure.

Dozer	Pilot Pressure in PSI [kPa]
	Test Port RI
TCi 920 (Y46F)	3,185 - 3,335 [21,960 - 22,994]

Table 3-10 Pilot Pressure Readings

DRAG-BRAKE Pressure Check

All installations with optional DRAG-BRAKE



Instructions

1. With the engine shut off, connect pressure gauge in line on the **DV** hose at the control manifold.
2. Start dozer and set to high-free idle
3. Measure pressure with the **DRAG-BRAKE** switch activated.
4. The drag brake requires 350 psi to fully engage. Low pressure will result in premature wear of the friction discs and added heat generation

If pressure is not at least 350 psi, check for:

1. Improper pilot supply pressure.
2. Malfunctioning solenoid valve.
3. Leaking pressure hoses or fittings.
4. Restriction in pressure hose or manifold port.
5. Leaking in gear side of winch. Watch oil level at the fill level plug to determine if there is leaking in gear side.

Figure 3-18 Test Equipment Setup

Test Equipment:

- (1) 1,000 psi (6,895 kPa) Gauges

Connect pressure gauges to test ports:

- **DV (Tee into existing line)**

Repairs

General

This section includes the disassembly of select components, the inspection of all major assemblies, and reassembly and installation. The wear points detailed in Figure 4-4 should be inspected at the time of disassembly so that worn parts may be ordered and replaced prior to reassembly.

NOTE: Always use the troubleshooting procedures given in Section 2 to locate a malfunction before performing a major overhaul of the unit. Make all checks in a systematic manner. Haphazard checking wastes time and can cause further damage.

Review and perform any adjustments that may be the cause of a malfunction (refer to Section 3).

Use new seals, gaskets and O-rings when installing components.



CAUTION

Cleanliness is of extreme importance in the repair and overhaul of any hydraulic unit. Before attempting any repairs, the exterior of the winch must be thoroughly cleaned to prevent the possibility of contamination.

Winch Removal

1. Remove the arch or fairlead from the winch. If these accessories are left on the winch, the winch will not remain level when lifted from the tractor.
2. Remove the wire rope from the drum. Clean the outside of the winch and the area where the winch contacts the tractor.



WARNING

Be careful when you remove the wire rope from the drum. The end of the wire rope can move like a compressed spring, causing an injury when the ferrule is released from the drum.

3. Disconnect hoses and wire harness from tractor.
4. Connect slings and a crane or lifting device to the winch. Install lifting eyes into the lifting holes provided in the frame.



WARNING

The slings and crane used to lift the winch must have a minimum lifting capacity of 1500 kg (3000 lb.).

5. Drain the oil from the winch.
6. Remove mounting hardware securing winch to tractor.

NOTE: When removing the mounting nuts or cap-screws, loosen all nuts slightly, then pry winch away from mounting pad. Loosen all nuts again and pry winch again. Continue this sequence until winch can be removed.

Winch Disassembly

See Figures 4-1 and 4-2 for the location of the Drum and Drum Shaft as well as the Freespool and Intermediate Shaft components.

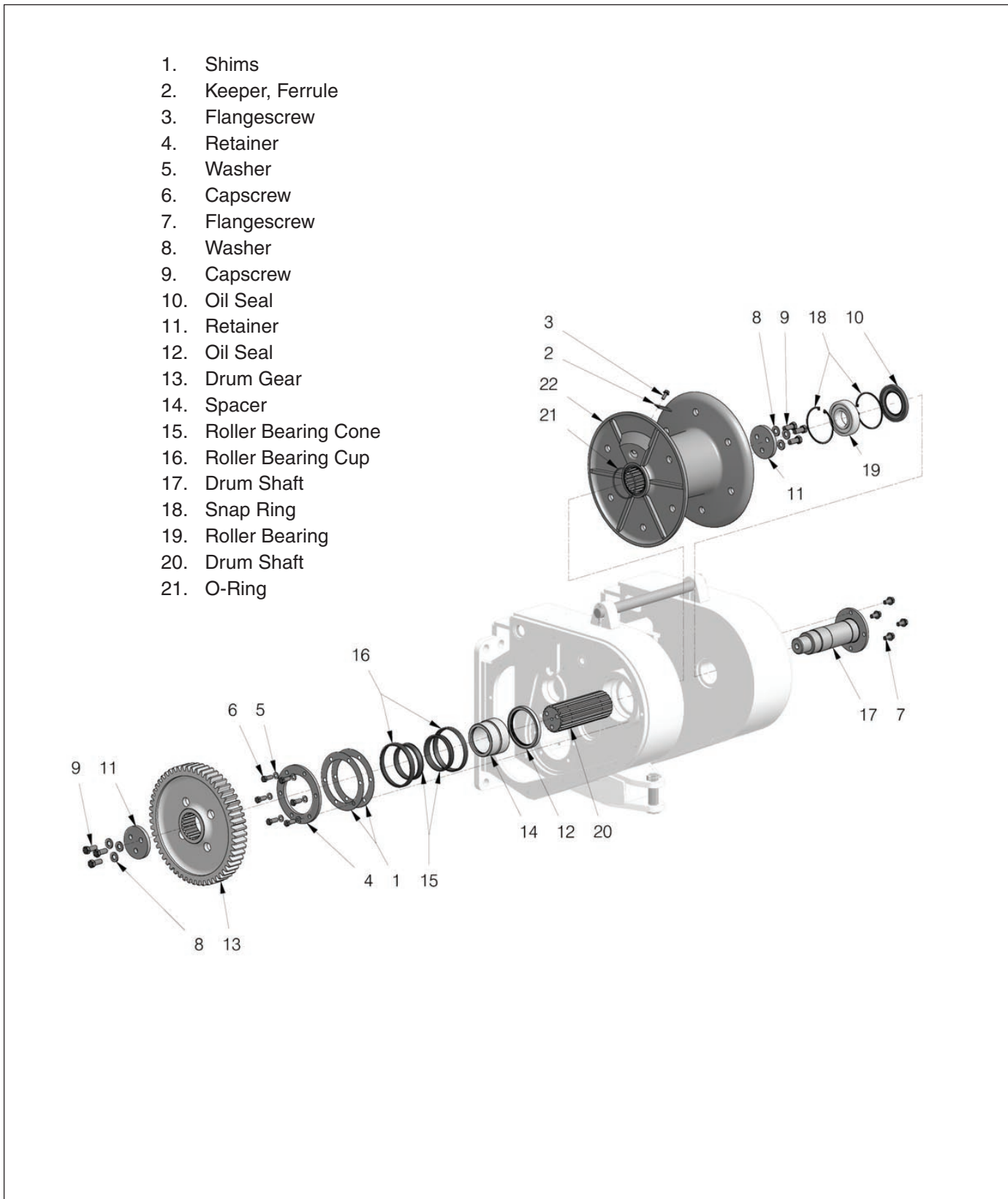


Figure 4-1 Location of Drum and Drum Shaft Components

- | | |
|----------------------------|------------------------------|
| 1. O-Ring | 11. Roller Bearing Cone |
| 2. Spring, Freespool | 12. Roller Bearing Cup |
| 3. O-Ring | 13. Nut |
| 4. Capscrew | 14. Screw |
| 5. Freespool Shaft | 15. Intermediate Gear |
| 6. Freespool Adjust Piston | 16. Freespool Shifter Fork |
| 7. O-Ring | 17. Freespool Adjust Housing |
| 8. Bearing Cone | 18. Flangescrew |
| 9. Roller Bearing Cup | 21. Fitting |
| 10. Pinion Shaft | 22. Hose Assembly |

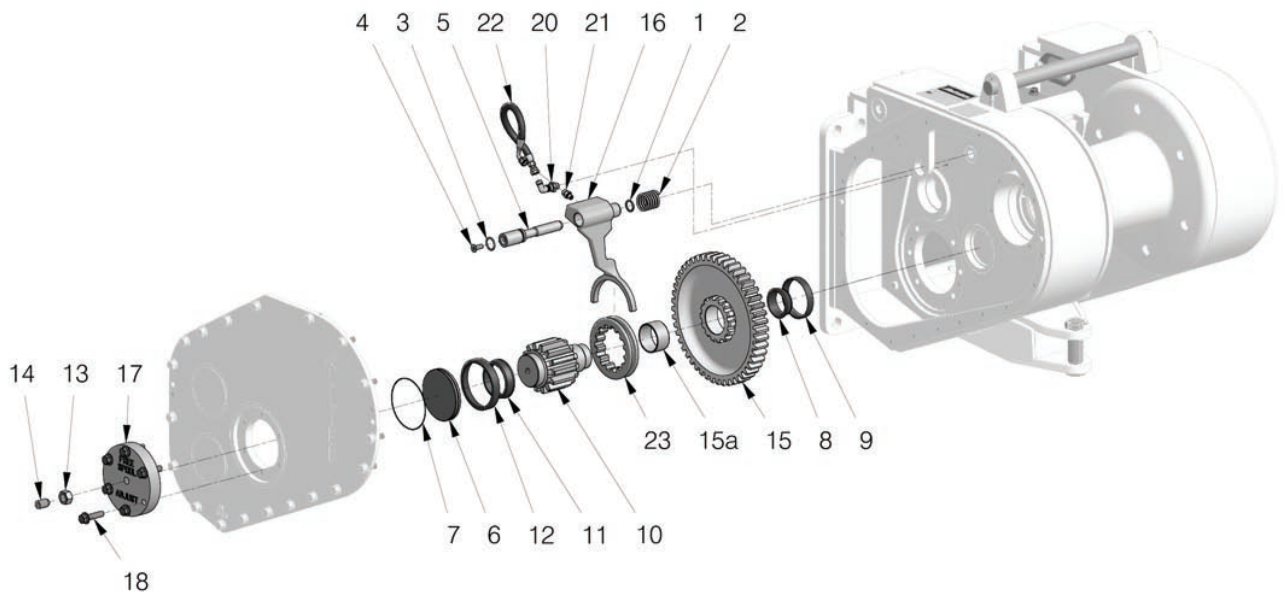


Figure 4-2 Location of Freespool and Intermediate Shaft Components

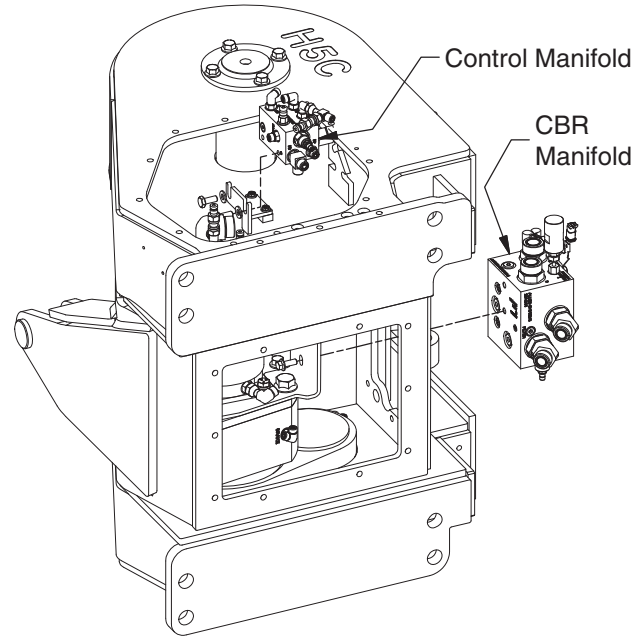
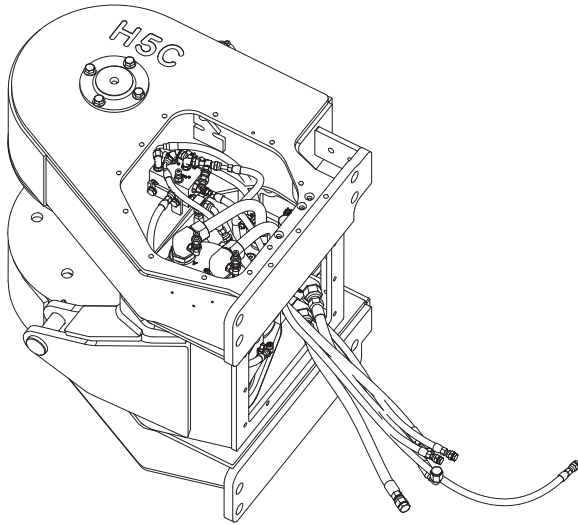
Motor Removal

Winches without optional DRAG-BRAKE

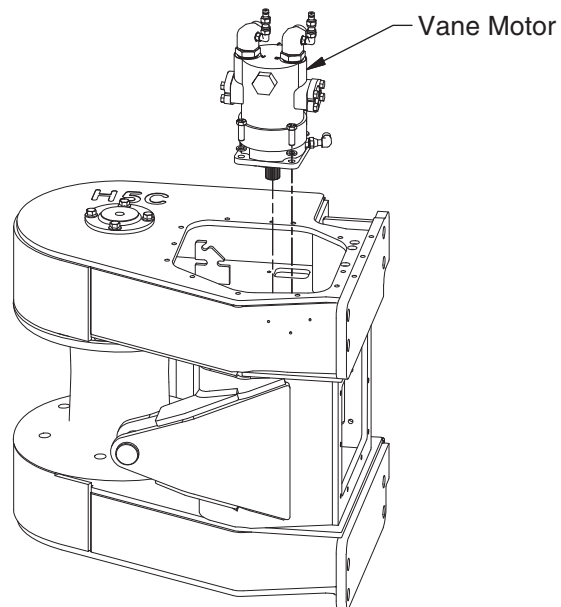
1. Drain oil from gear compartment or remove breather and install pipe plug.

Note: Tag or label all hydraulic hose ends and tubes to aid during reinstallation. Also note the location of any hose clamps.

2. Remove winch from tractor.
3. Position winch on its left side and block securely.
4. Remove right-hand side cover, front cover, and top cover.



5. Remove all hoses, wiring harnesses, and tube assemblies. Tag hose ends and ports for reassembly. Use caps to prevent contamination of open ports and hose ends.
6. Remove the control manifold and counterbalance relief (CBR) manifold.
7. Remove the four fasteners in the motor flange. Then you can remove the motor, using a suitable lifting strap or device. Note motor orientation to aid in reinstallation.



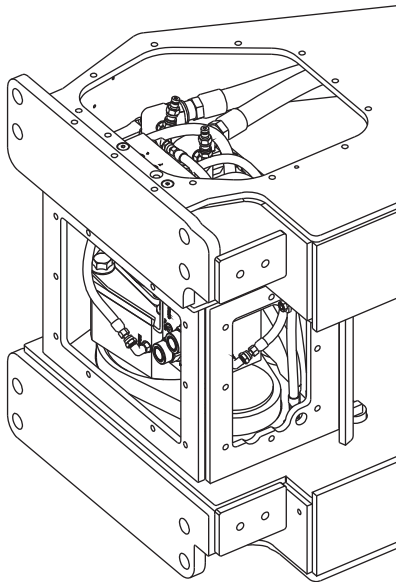
Motor Removal

Winches with optional DRAG-BRAKE

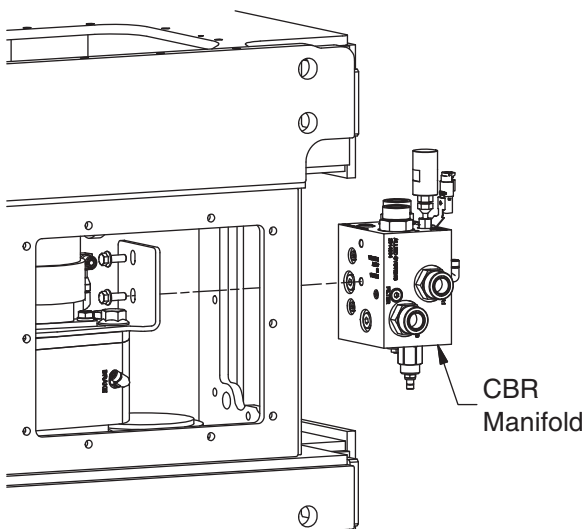
1. Drain oil from gear compartment or remove breather and install pipe plug.

Note: Tag or label all hydraulic hose ends and tubes to aid during reinstallation. Also note the location of any hose clamps.

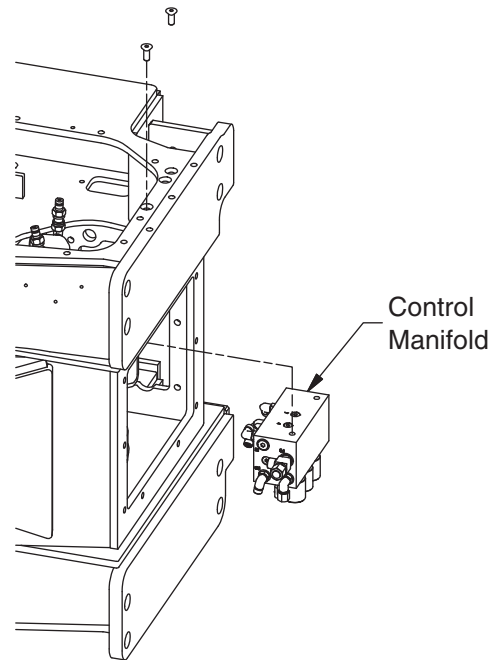
2. Remove winch from tractor.
3. Position winch on its left side and block securely.
4. Remove right-hand side cover, front cover, and top cover.



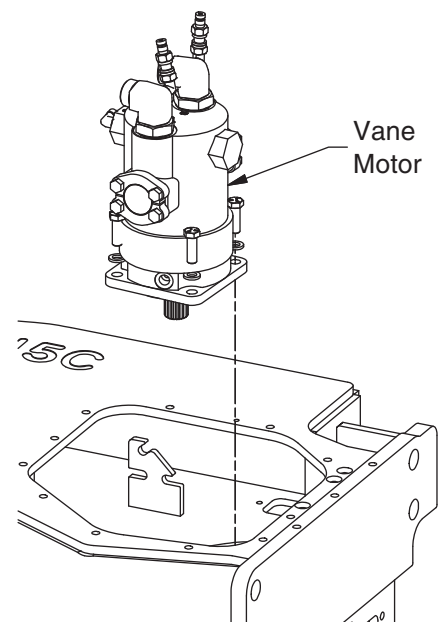
5. Remove all hoses, wiring harnesses, and tube assemblies. Tag hose ends and ports for reassembly. Use caps to prevent contamination of open ports and hose ends.
6. Remove the counterbalance relief (CBR) manifold.



7. Remove the control manifold.



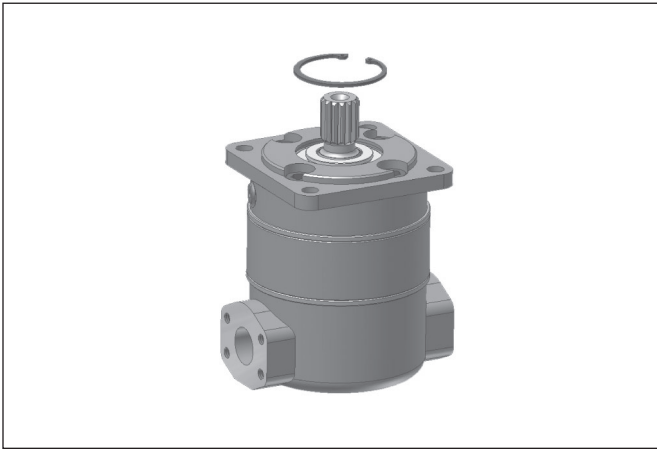
8. Remove the four fasteners in the motor flange. Then you can remove the motor, using a suitable lifting strap or device. Note motor orientation to aid in re-installation.



Motor Disassembly

NOTE: Disassembling the motor while it's still under its warranty period immediately invalidates the warranty. If the motor malfunctions before its warranty period expires, please contact Allied Systems Company first before attempting to repair it.

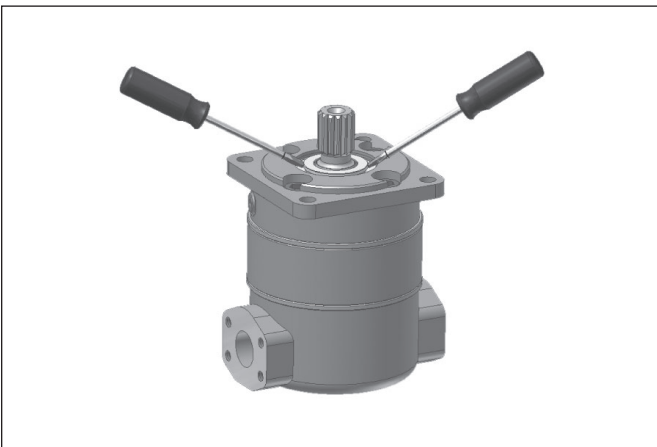
1. Remove snap ring.



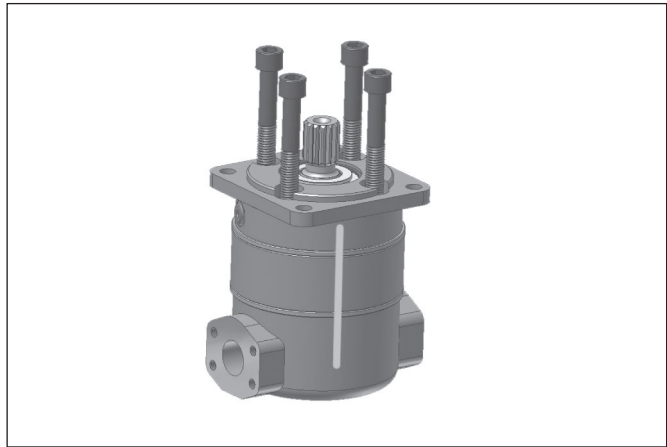
CAUTION

Use caution when removing snap ring. If released accidentally, it can become an airborne hazard.

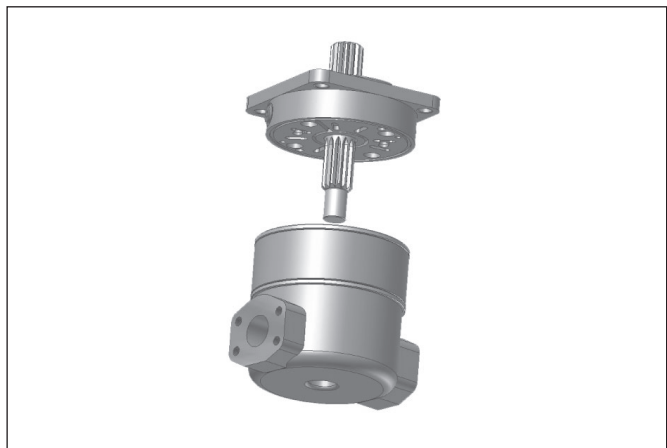
2. Pry out shaft seal plate with two screwdrivers. Remove seal plate O-ring from groove in bearing bore.



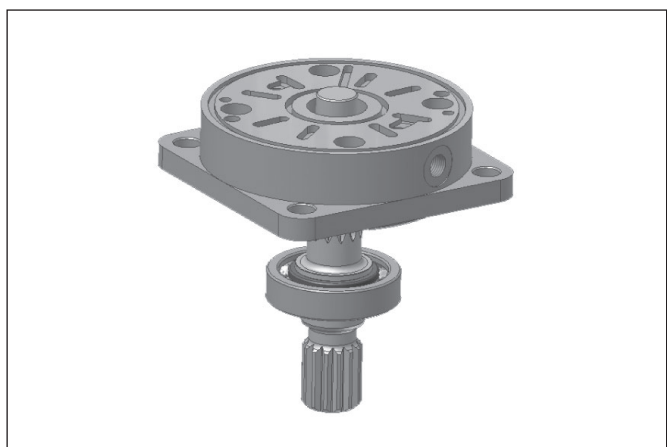
3. Mark one side of the motor for proper assembly, paying careful attention that the cartridge will not be installed upside down. Secure the motor prior to loosening the 5/8-11 bolts.



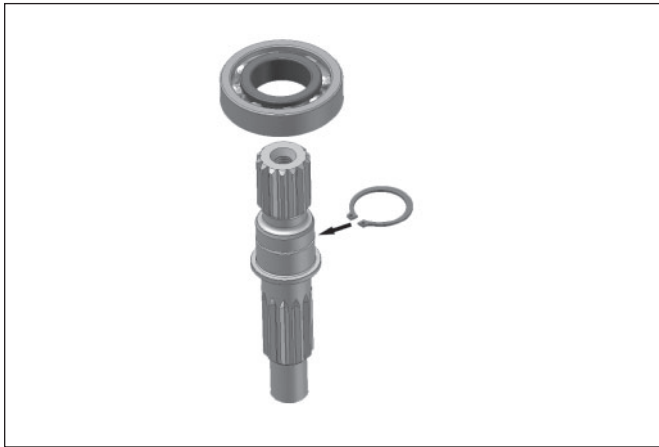
4. Remove front housing. **NOTE: Two 5/16" ball checks and one main body O-ring may be dislodged and fall free.**



5. With the seal plate removed, press shaft and ball bearing out of front housing.



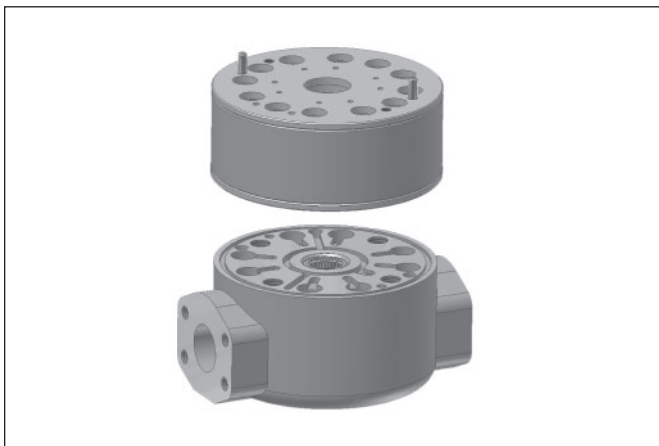
6. Remove snap ring from shaft. Press shaft out of bearing.



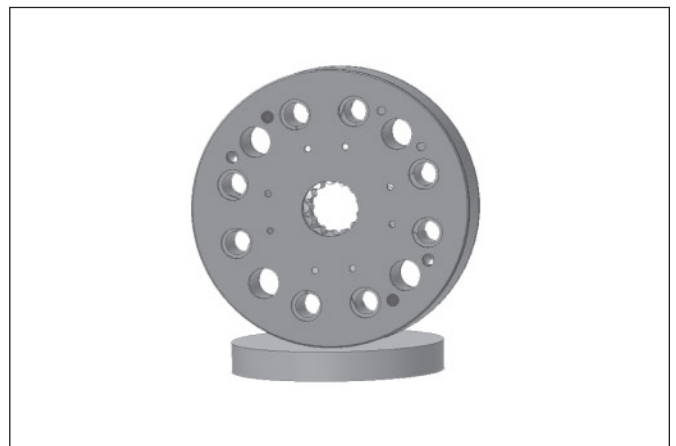
9. Remove O-ring and springs with a small screwdriver. Remove dowel pins.



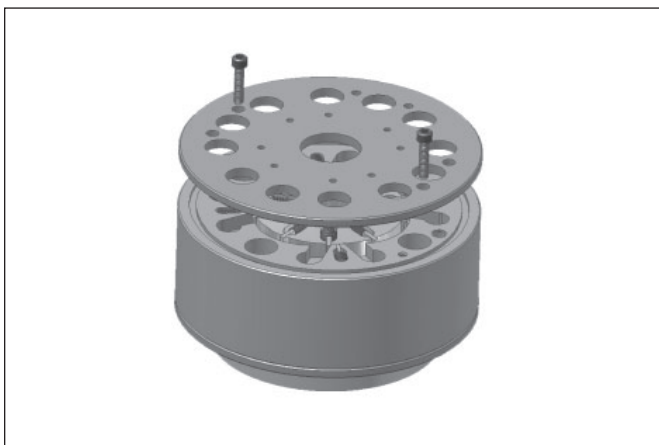
7. Lift up rotor/stator cartridge and remove from the rear housing.



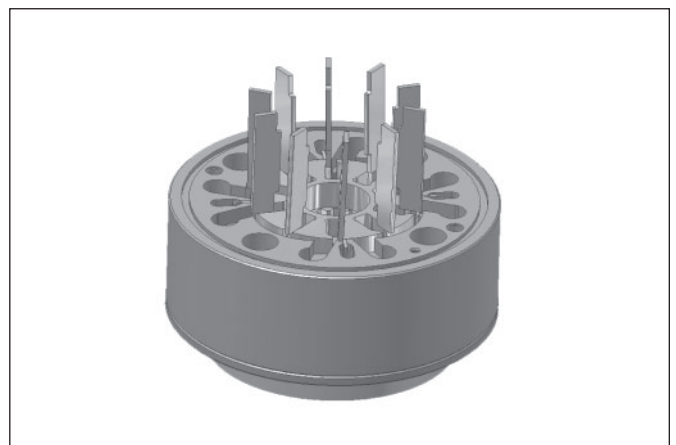
10. Replace plate on rotor/stator cartridge. Turn rotor/stator cartridge over.



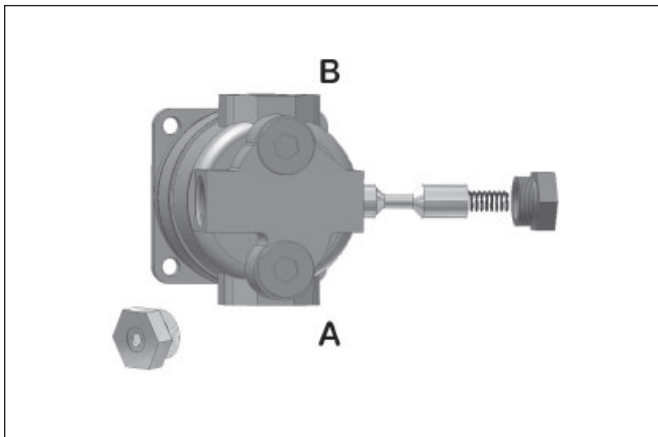
8. Place cartridge on any object which will hold it off the table. Remove screws and timing plate.



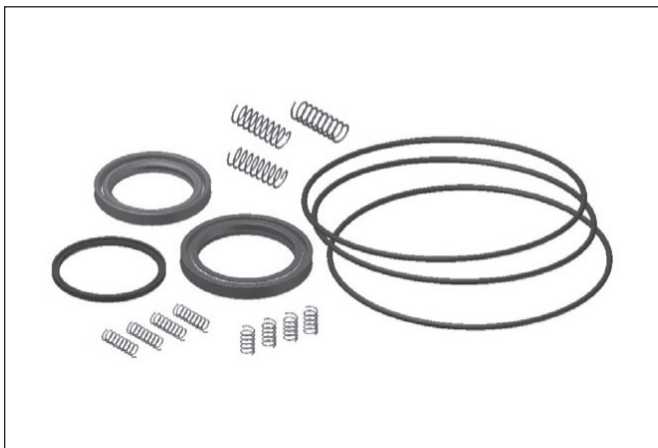
11. Remove the rotor. Remove both the rotor and stator vanes.



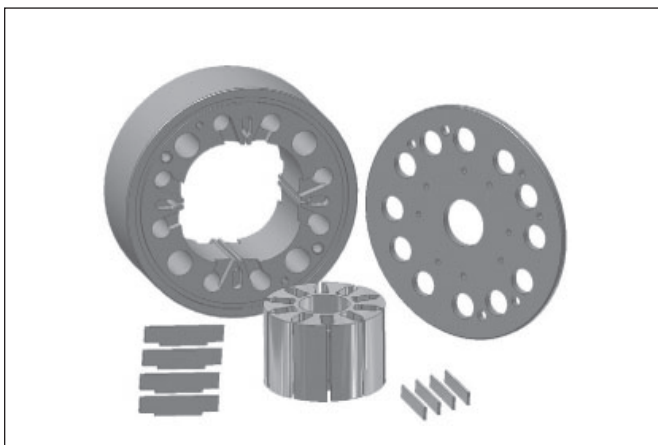
12. Remove the spool assembly.



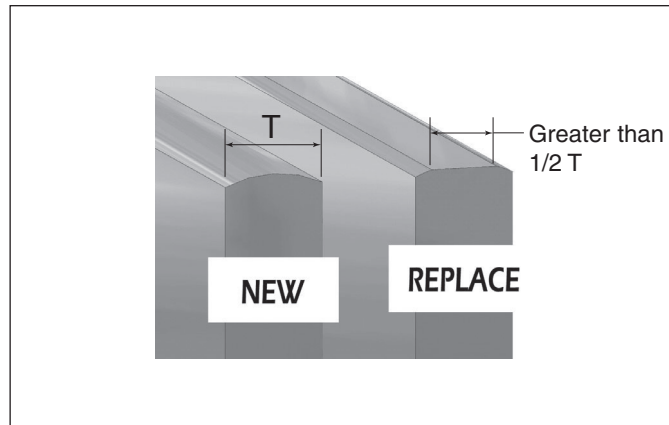
13. Inspect all springs and seals. We recommend replacement of all seals and springs whenever the motor has been disassembled.



14. Inspect all parts and replace any parts which obviously show excessive wear or damage.



15. **Vanes:** Normal wear results in slight flattening of vane tips which does not impair motor performance. Replace vane if radius is reduced by 50%. Clearance between the rotor vane and rotor vane slot varies with the vane selection. The design allows the vane to “lean” slightly in the slot, providing the required mechanical seal.

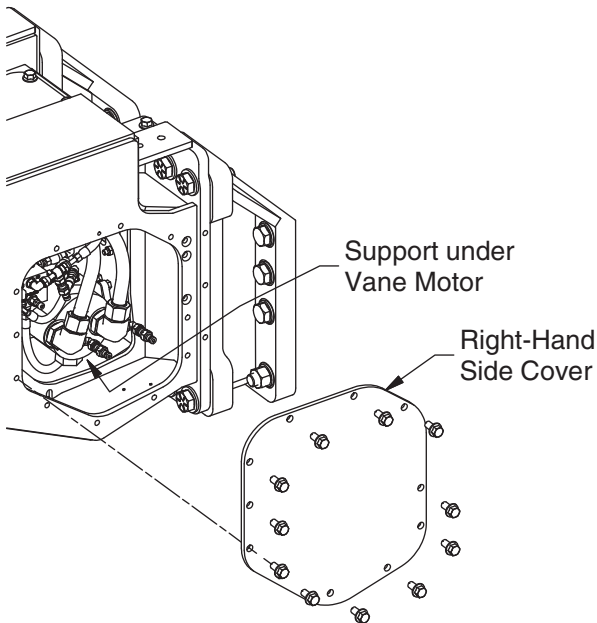


Intentionally Blank

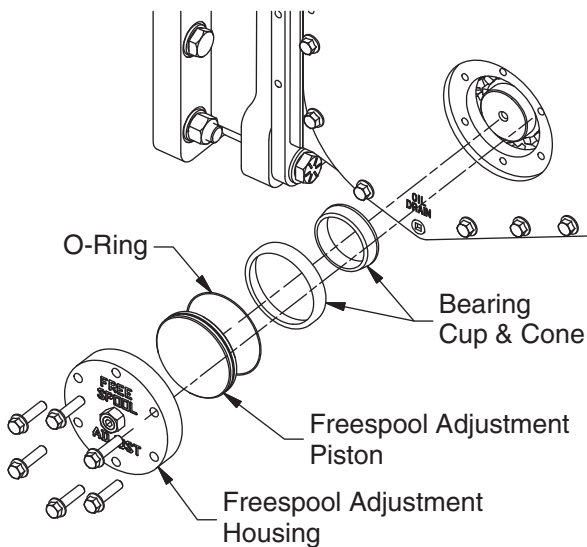
Brake Removal

If you need to service the brake piston, you need to remove the hydraulic motor to get access to the entire brake assembly by using the following procedure.

1. Drain winch case oil into a suitable container and dispose of properly.
2. Position the winch in the upright position. Remove the right hand side cover.
3. Place a support under winch motor to hold it in position.

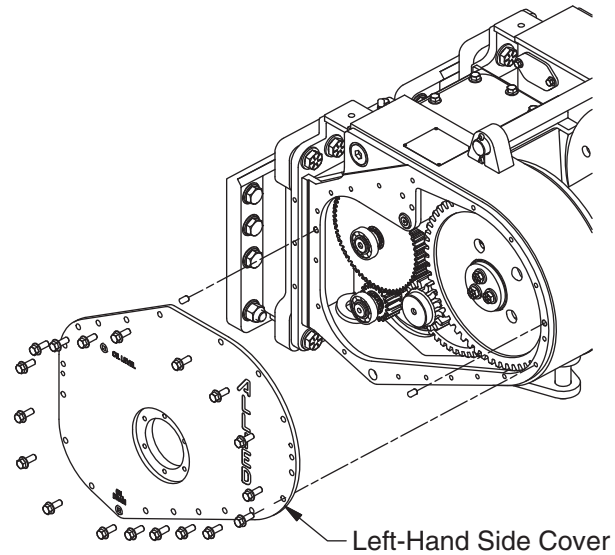


4. On the left side cover, remove the freespool adjustment housing, freespool adjustment piston, the bearing cup and cone.

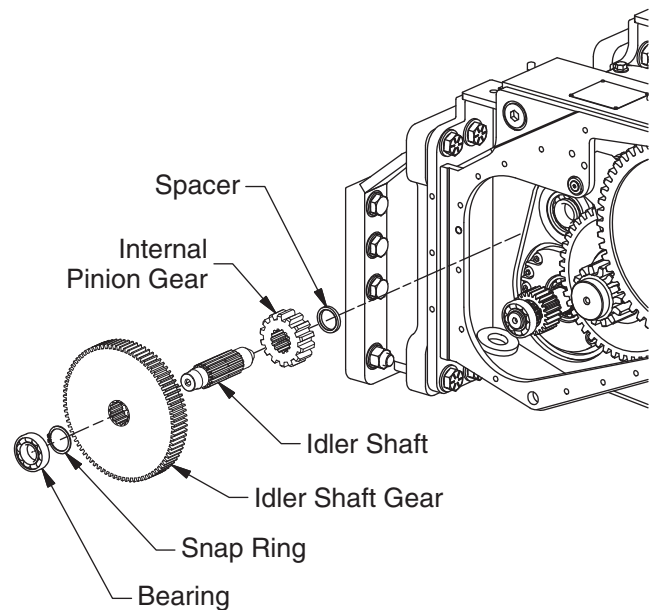


5. Remove the left hand frame side cover.

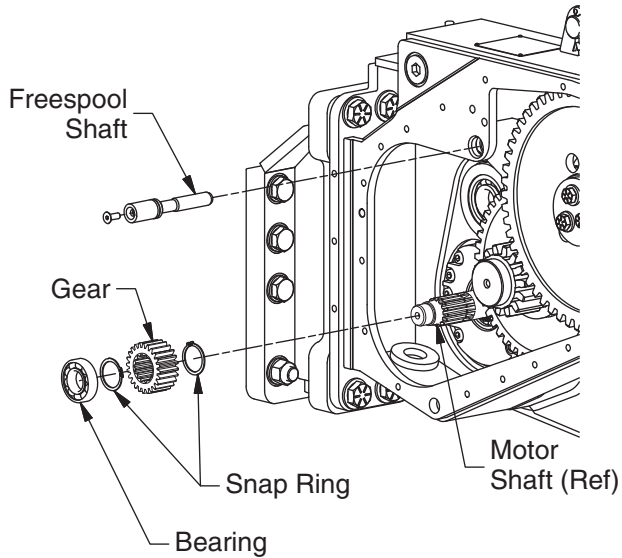
Note: Be aware that the freespool shaft, idler shaft and bearing, and the bearing for the motor shaft may drop down out of position.



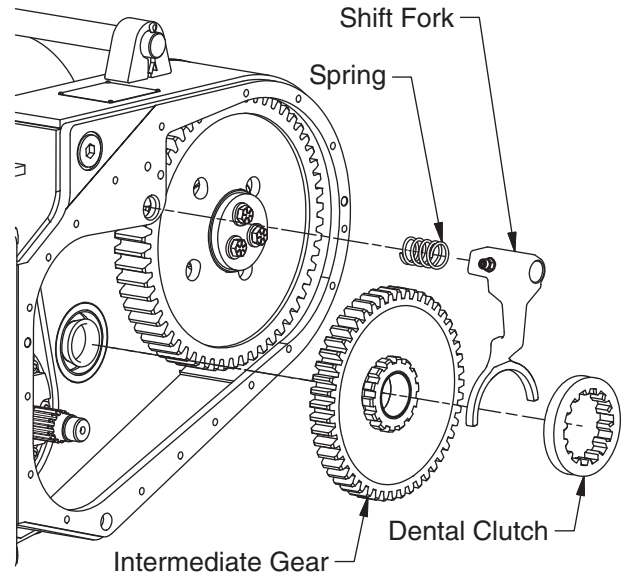
6. Remove the idler shaft and gears.



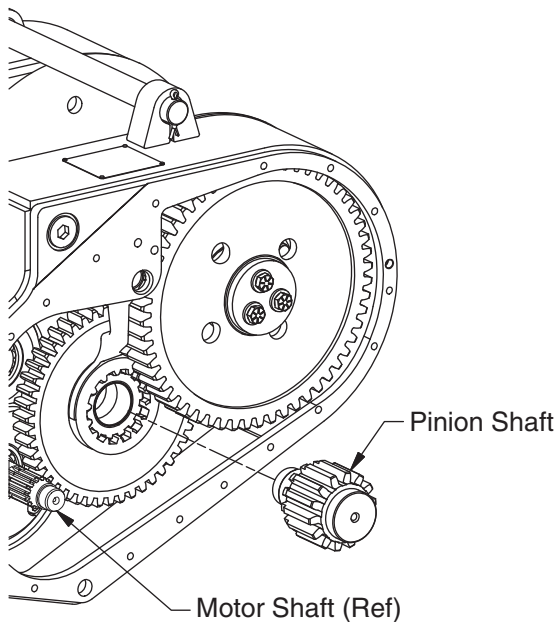
7. Remove freespool shaft, the gear and the bearing from the motor shaft.



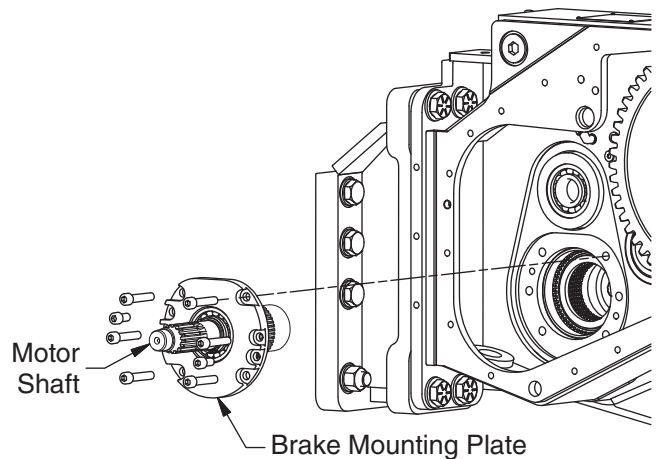
9. Disconnect the freespool hydraulic hose, remove the shift fork assembly and the intermediate gear.



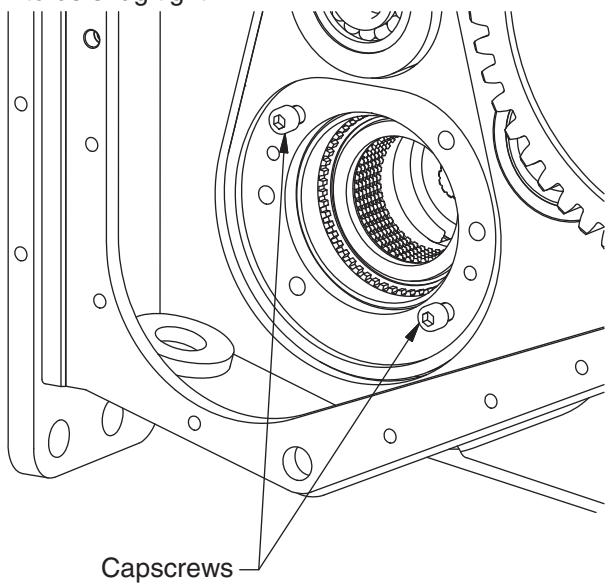
8. Remove the pinion shaft.



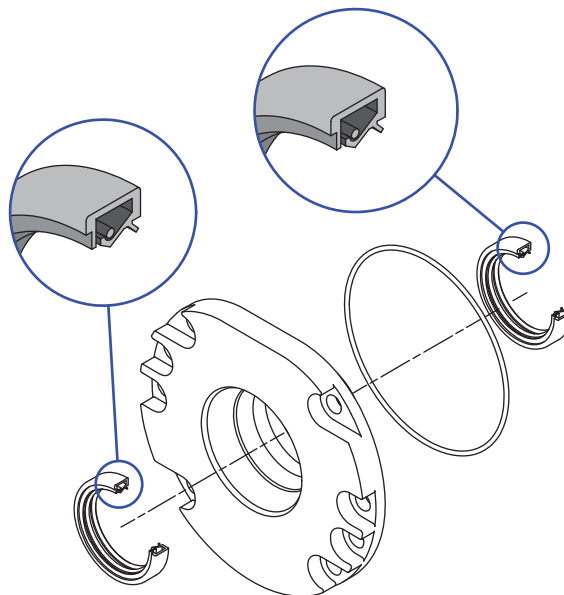
10. Remove the capscrews from the brake mounting plate, and use the shaft-like slide hammer to pull out the motor shaft and the brake mounting plate together.



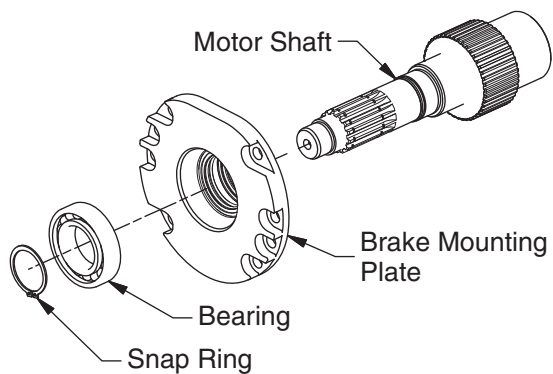
11. Temporarily install two longer capscrews removed from the brake mounting plate, to hold the brake housing to the winch frame. These capscrews need to be snug tight.



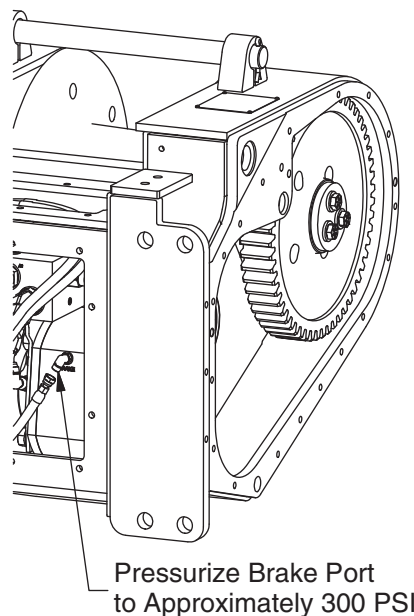
13. The oil seals are contained in the brake mounting plate. Inspect the seals for damage and note the direction they are installed.



12. Remove the snap ring holding the roller bearing, and separate the brake mounting plate and the motor shaft.



14. To remove the internal snap ring that holds the brake discs in place you will need to pressurize the brake port to approximately 300 psi, using a suitable hand pump.



This holds the brake piston back and relieves the tension on the brake disc.

⚠ CAUTION

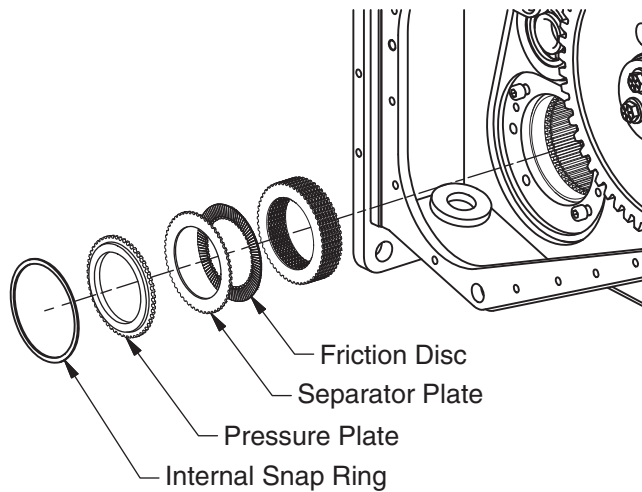
Should pressure be lost during this procedure, personal injury may occur from pinched fingers and flying tools.

15. Once the internal snap ring is fully removed, slowly release the pressure from the brake port. The pressure plate and brake disc should move out as the pressure is released.

16. Inspect the friction disc for wear and the separator plates for wear and flatness.

Note: Care should be taken to keep the friction disc free from oil contamination. Any oil on the friction disc will decrease the holding capacity of the brake and they must be replaced.

At this point if you need to access the piston, then disconnect and remove the winch motor and housing as an assembly. You must remove the two temporary capscrews installed after the removal of the brake mounting plate in step 10.



Brake Disassembly

1. Remove the motor from the motor mounting plate. Refer to Hydraulic Motor Removal procedures described earlier. Then loosen the two 1/2" capscrews (one at the 12 o'clock, and one at the 6 o'clock position).

CAUTION

The mounting plate holds the brake springs under tension. Loosen capscrews alternating, one turn each to slowly un-cage the springs.

2. Once all tension is relieved from the mounting plate, remove the capscrews, and pull out the two springs. Note the spring orientation for re-assembly.

3. Remove brake piston and brake discs.

CAUTION

The brake is a dry multi-disc design. Do not get any oil on the friction disc. If the friction discs are contaminated with oil, the brake will greatly reduce holding power, and the brake discs must be replaced.

4. Remove the external snap ring and sleeve from brake housing.
5. Using a small magnet, remove friction and separator discs from brake housing.
6. To remove brake housing, the brake mounting plate and motor shaft must be removed from gear side of winch.

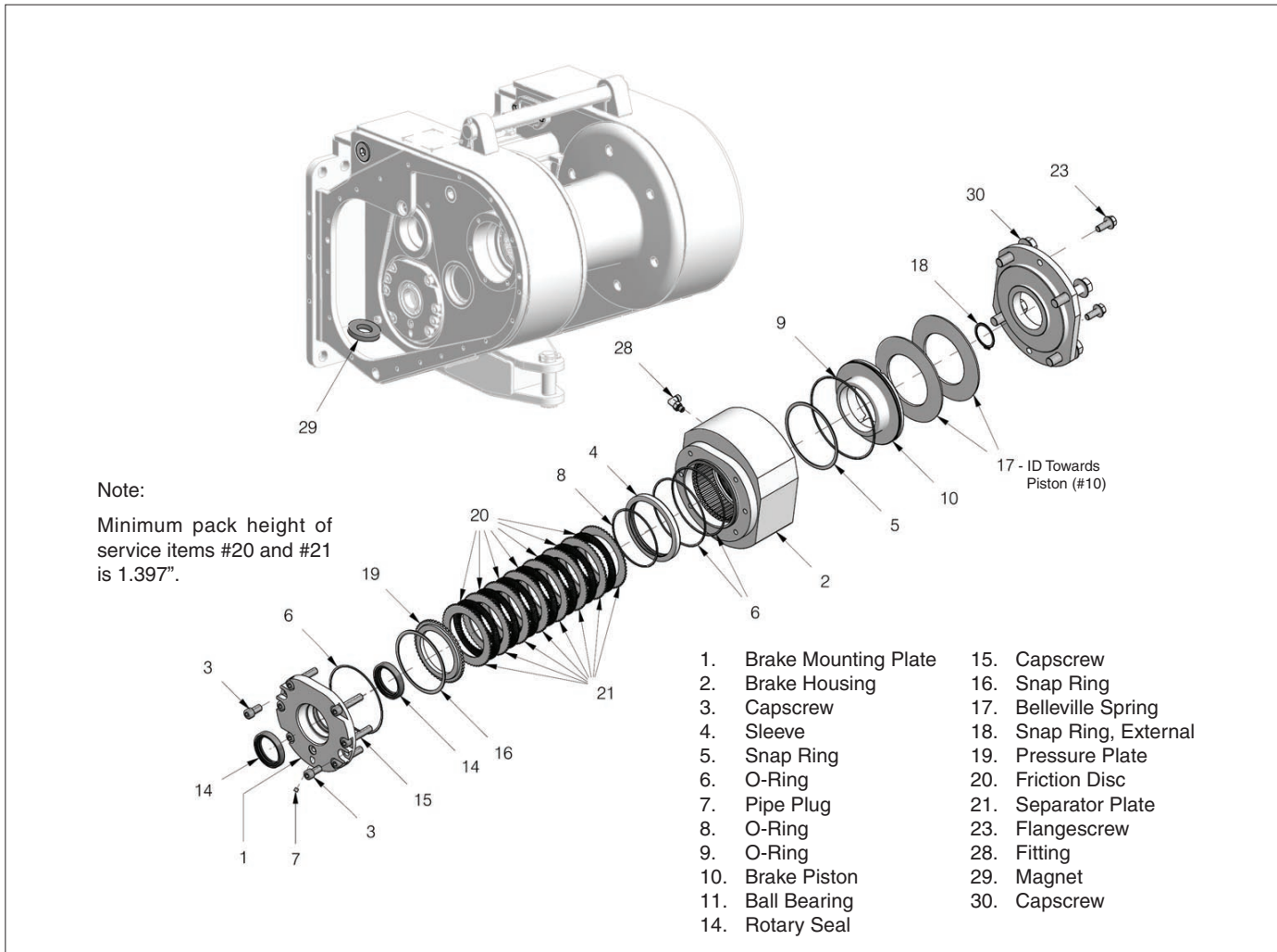
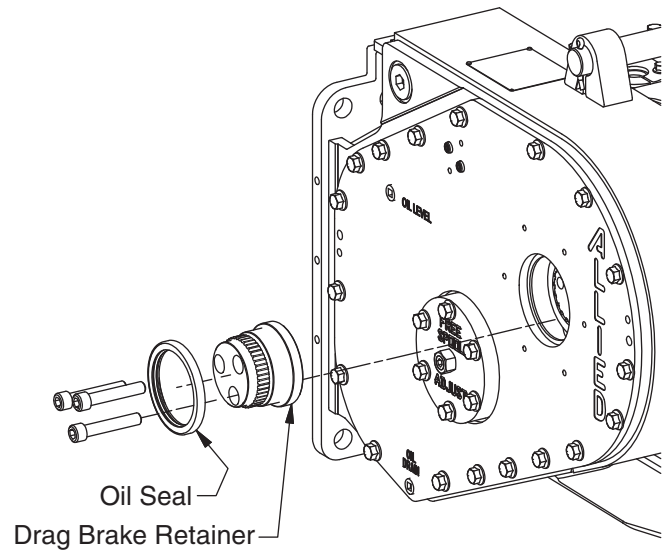
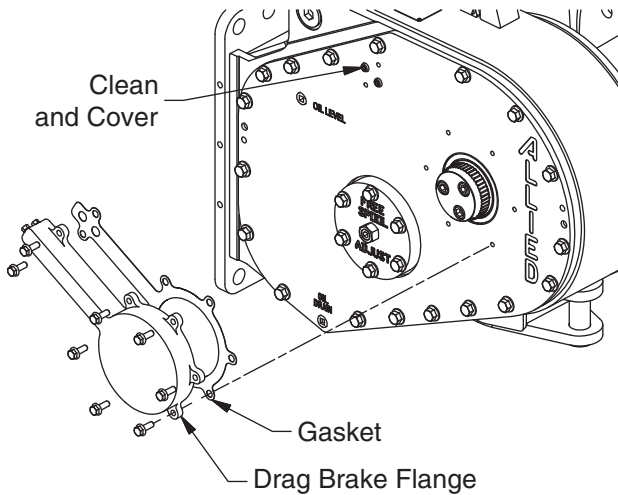


Figure 4-3 Brake Assembly

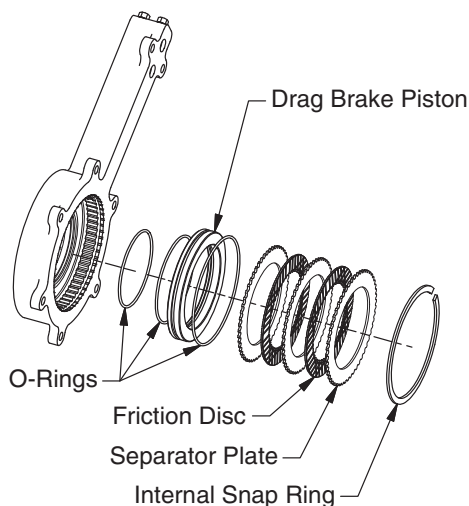
Drag Brake Disassembly

If you need to service the drag brake (winches with optional **DRAG-BRAKE**):

1. The drag brake may be serviced with the winch still installed on the dozer if necessary.
2. Clean the exterior of the left side of the winch.
3. Slowly remove the capscrews and drag brake flange.
4. Remove and discard the gasket.
5. Clean the area around the open fittings on the left cover, and cover them to prevent contamination.
6. Once the drag brake flange is removed, carefully remove the internal snap ring, and the three separator plates and two friction discs.
7. Remove the drag brake piston, and all O-Rings. Discard all O-Rings.
8. Remove the drag brake retainer and oil seal. Discard the oil seal.



6. Once the drag brake flange is removed, carefully remove the internal snap ring, and the three separator plates and two friction discs.



Winch Assembly

All components should be inspected for wear or damage as they are removed. Refer to Figure 4-4, Visual Inspection. All seals that were removed should be replaced during assembly. Carefully inspect all bearings that have

been removed. Used bearings often appear satisfactory, but may fail when placed under a load. When in doubt, it is recommended to install a new bearing. Any component that indicates excessive wear or damage should be replaced. The following reassembly and installation sequence assumes a complete winch overhaul.

Figure 4-4 Visual Inspection

ITEM	INSPECTION REQUIREMENTS	CORRECTIVE ACTION
Drag Brake Assembly	Inspect flange for leakage or damage.	Replace if sealing surfaces are damaged
	Check the friction discs for wear, distortion, or damage. The discs should be free of hydraulic oil.	Replace the friction discs if the wear grooves are worn away, the discs are burned, damaged, warped, or exposed to oil. Brake cleaner may be used to clean dust from the discs but will not remove impregnated oil.
	Check that the separator plates are flat, free of large blue areas (caused by overheating) or damaged surfaces.	Replace damaged separator plates.
Brake Assembly	Check for cracked or broken belleville/coil springs.	Replace springs if cracked or broken.
	Inspect housing and covers for leakage or damage.	Replace component if sealing surfaces or splines are damaged.
	Check the friction discs for wear, distortion, or damage. The discs should be free of hydraulic oil. The minimum pack thickness is 1.397".	Replace the friction discs if the wear grooves are worn away, the discs are burned, damaged, warped, or exposed to oil. Brake cleaner may be used to clean dust from the discs but will not remove impregnated oil.
	Check the brake/motor shaft seals for leakage into the brake housing.	Replace damaged seals.
	Inspect the brake/motor shaft for wear or damage.	Replace a damaged shaft.
	Check that the separator plates are flat, free of large blue areas (caused by overheating) or damaged surfaces.	Replace damaged separator plates.
	Inspect the piston for damage. Make sure the seal groove and sealing surfaces are in good condition.	Replace a damaged piston. Always replace the piston seals when the brake is repaired.
Counterbalance Relief Manifold	Check that all passages and cartridge valves are free of contaminants.	Clean or replace cartridge valves. Clean all hydraulic passages.
Control Manifold	Check that all passages and cartridge valves are free of contaminants.	Clean or replace cartridge valves. Clean all hydraulic passages.
	Check torque on solenoid coils. Do not over-tighten.	Check that solenoid spool moves freely. Replace cartridge if stiction is present. Torque for solenoid cartridge is 20 ft-lbs. Torque for coil retaining nut is 5 ft-lbs.

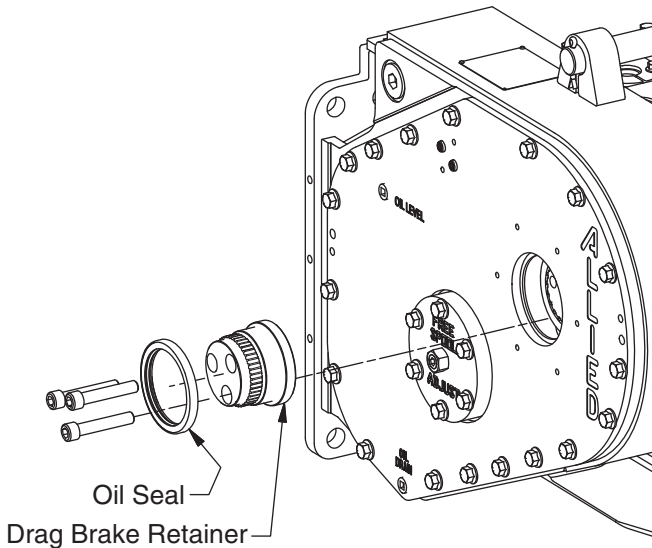
(Continued on next page)

Figure 4-4 Visual Inspection (continued)

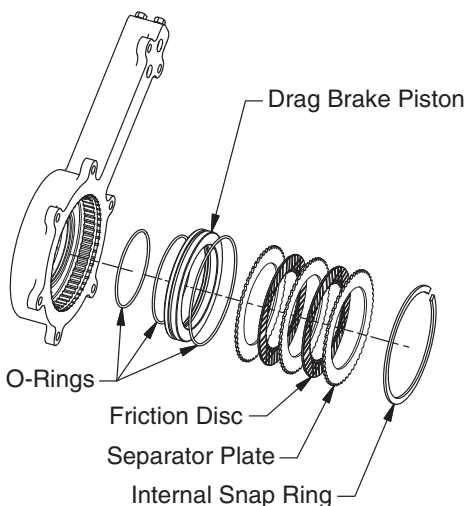
ITEM	INSPECTION REQUIREMENTS	CORRECTIVE ACTION
Winch Motor	Inspect motor shaft seal for wear or damage.	Note: A leaky motor shaft seal will contaminate the brake with oil and the brake will likely require service. Replace seal.
	Inspect vanes for wear or damage.	Normal wear results in slight flattening of vane tips, which does not impair motor performance. Replace vanes if radius is reduced by 50%.
	Inspect plates for wear or damage.	Normal wear results in marking of timing plates which does not impair motor performance. Replacement of the timing plate is required if any smearing, galling, or heat cracks are present.
	Inspect stator for wear or damage.	Normal wear results in polishing of cam form which does not impair motor performance. Noticeable wear may be apparent along the corner of one side of the vane slot. This does not require replacement of the stator, but may slightly affect volumetric efficiency.
Freespool Shifter	Check oil level in winch is not over full. This is an indication that the freespool hose or piston seals are leaking.	Tighten or replace freespool shifter hose. Replace piston seals.
Freespool Dental Clutch	Check for broken or worn teeth.	Replace dental clutch if teeth are broken or severely worn.
Intermediate Shaft	Check for deep scratches or scoring on bearing surfaces at each end of shaft.	Dress surface or replace shaft if severely worn.
	Check for broken or severely worn splines.	Replace if splines are broken or severely worn.
Intermediate Gears	Inspect both gears for broken or severely worn teeth. Pay particular attention to leading edges of straight-cut gear teeth.	Replace gears if teeth are broken or severely worn.
Drum Shaft	Check for deep scratches or scoring on bearing surfaces.	Dress surface or replace shaft if severely worn.
	Check O-ring groove and seal surface.	Dress groove or replace shaft if severely worn.
	Check for crosstreaded or damaged threads.	Dress threads with thread chaser.
Drum Gear	Check for broken or severely worn gear teeth. Pay particular attention to leading edges of straight-cut gear teeth.	Replace gear if teeth are broken or severely worn.
Drum	Inspect quad-ring groove for burrs, scoring and rust.	Replace drum or rebuild drum groove if a new quad-ring will not seat properly.
Drum Adapter	Carefully inspect double seal contact surface for deep scratches, burrs and rust.	Replace if damaged.
Winch Frame	Check area around drum and drum adapter for damage if cable has slipped between cable guard and winch frame.	Consult the factory.

Drag Brake Assembly

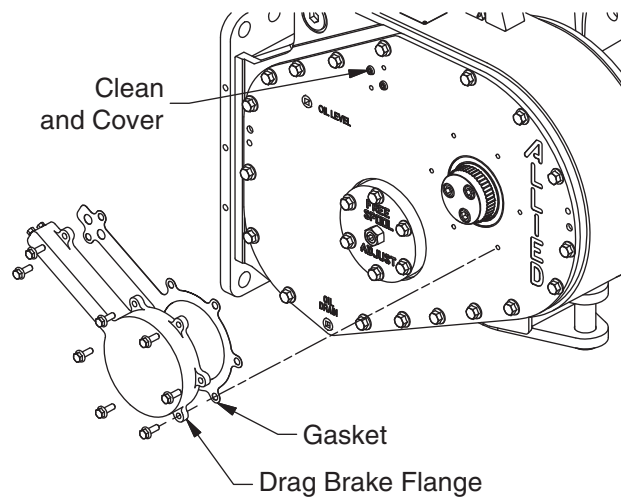
1. Clean all parts thoroughly. All O-rings, the oil seal, and the gasket should be replaced.
2. Install the drag brake retainer with the three cap-screws, and install a new oil seal. Torque capscrews to approximately 160 ft-lbs.



3. Install new O-rings on the piston and lightly coat with hydraulic oil. Install new O-ring in the drag brake flange. Install the drag brake piston into the drag brake flange.
4. Install brake discs starting with a separator disc, and then alternate with a friction disc. You should start and end with a separator disc.



5. Manually align the internal teeth on the friction discs.
6. Install the internal snap ring to retain the friction and separator plates.
7. Reinstall the drag brake flange. Rotate the flange until the internal teeth on the friction disc engage with the external teeth on the drag brake retainer. Use a new gasket.
8. Make sure that the two hydraulic ports are aligned with the two o-ring face seal bulkhead fittings in the left-hand cover.
9. Torque capscrews to approximately 35 ft-lbs.
10. Once winch is operational again, check for external and internal leaks and proper operation. Check for internal leaks by running the drag brake function to see if the gear side oil level changes.



Brake Assembly

1. Clean all parts thoroughly.
2. Install brake discs starting with a separator disc, and then alternate with a friction disc. You should start and end with a separator disc.

CAUTION

The brake is a dry multi-disc design. Do not get any oil on the friction discs. If the friction discs are contaminated with oil, the brake will greatly reduce holding power, and the brake discs must be replaced.

3. Install new o-rings on the piston and lightly coat with hydraulic oil. Do not get any oil on brake discs, see Caution above.

4. Install brake springs. Make sure that they are stacked together like dinner plates with the outer rim towards you.
5. Install mounting plate. Hand tighten all four cap-screws evenly. Then tighten one turn at a time in rotation until mounting plate is flat against the brake housing. Torque capscrews to 285 lbs ft.
6. Reinstall the motor, replace o-rings on motor pilot. Torque 1/2" capscrews to 80 lbs ft. (3/4" capscrews to 285 lbs ft.).
7. Connect hydraulic hard lines and hose. Replace any o-rings that were disturbed with new.
8. Install side cover. Once winch is reinstalled on the tractor, check for leaks, pressure settings, and proper operation.

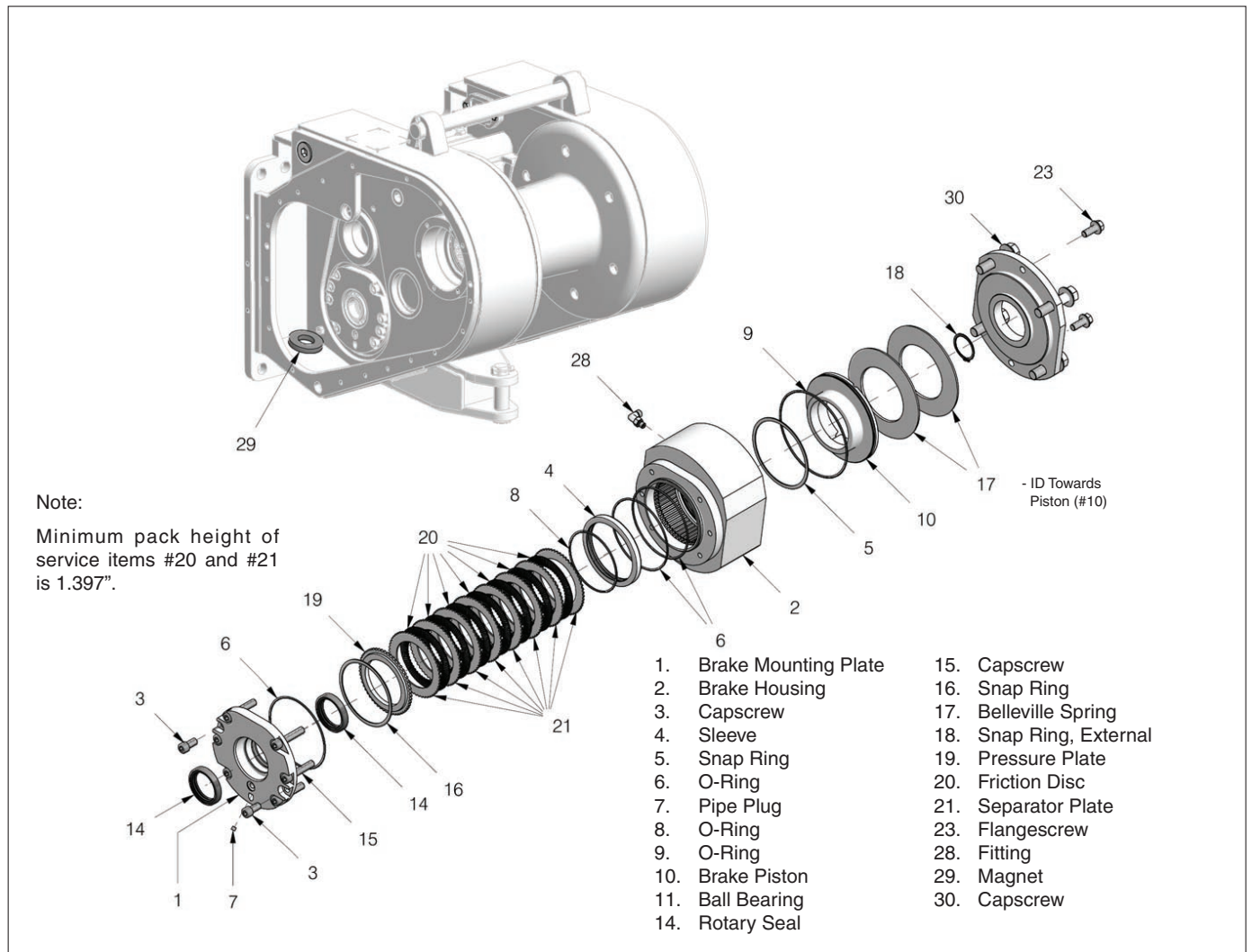
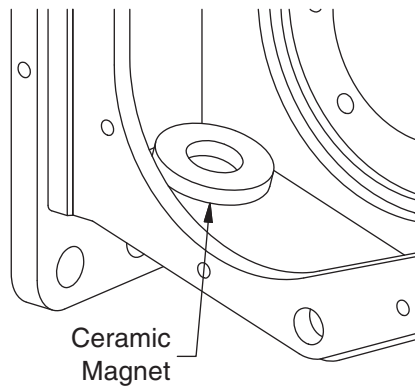


Figure 4-5 Brake Assembly

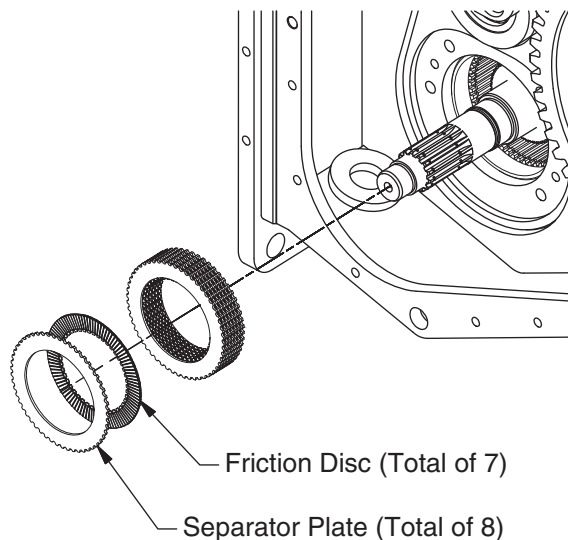
Brake Installation

1. Remove, clean, and then re-install the round magnet that is positioned on the bottom of the winch case ahead of the drain port.

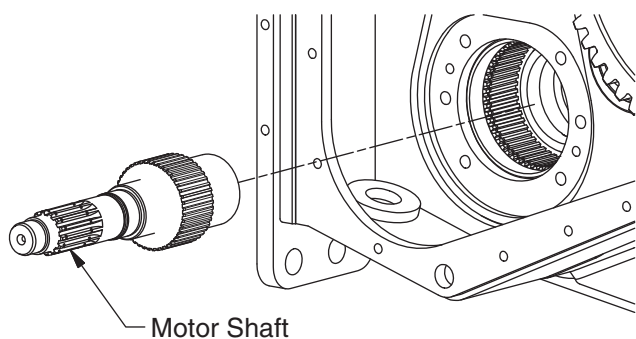


3. Install the brake disc starting with separator plate, then a friction, and continue alternating. You should end with a separator plate. There should be a total of (8) separator plates and (7) friction discs.

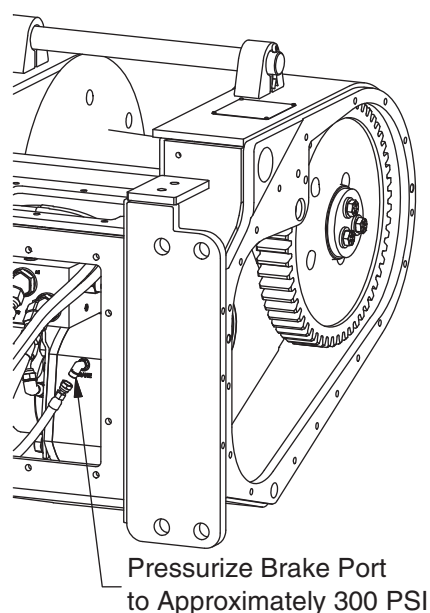
Note: Care should be taken to keep the friction disc free from oil contamination. Any oil on the friction discs will decrease the holding capacity of the brake and they must be replaced.



2. Insert the motor shaft, engaging the splines on the motor.



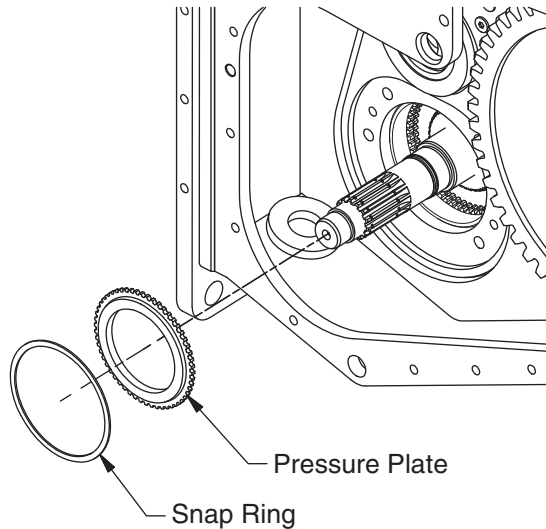
4. Connect the hand pump to the brake port and pressurize to 300 psi.



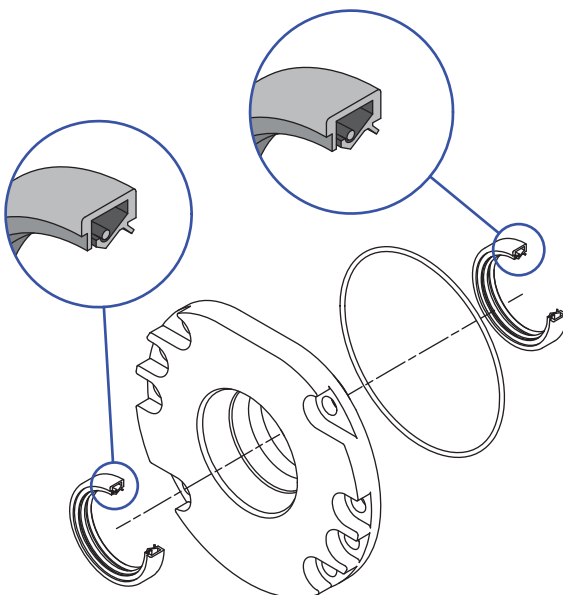
- With the piston fully retracted, install the pressure plate and the internal snap ring into the groove in the brake housing. Once the pressure plate and the internal snap ring are fully seated, slowly release the pressure.

⚠ CAUTION

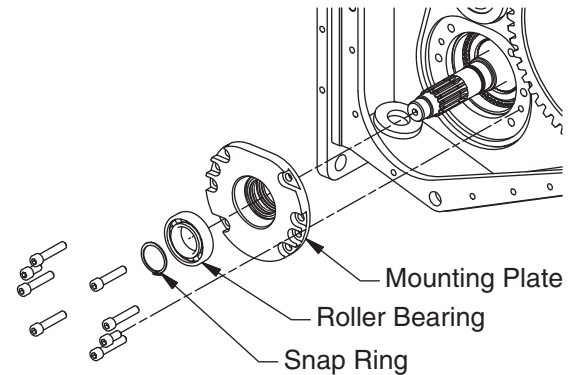
Should pressure be lost during this procedure, personal injury may occur from pinched fingers and flying tools.



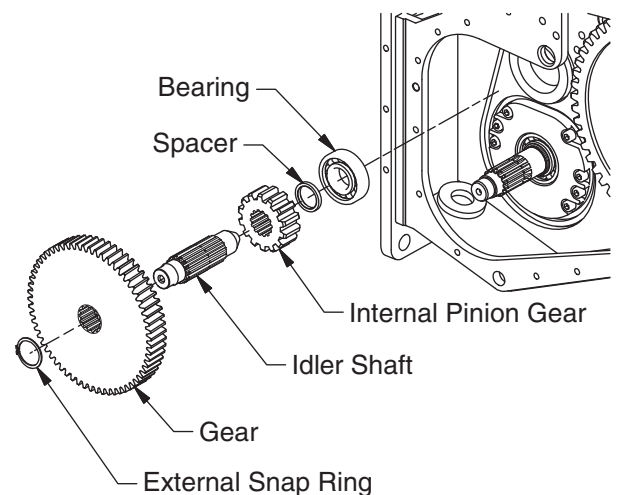
- Install new seals in the brake mounting plate. Be sure to install the seals in the correct direction. Lubricate new seals with a very light coat of hydraulic oil. **Do not get any oil in the brake housing where the brake discs are.**



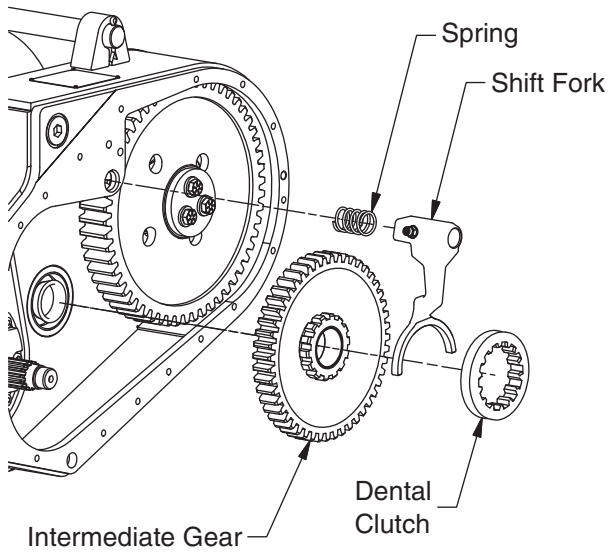
- Install the roller bearing in to the mounting plate to help guide the seals over the shaft, to prevent damage to the lip seals.
- Remove the two temporary capscrews.
- Install the mounting plate, and torque the capscrews to 80 LBS FT.
- Install snap ring on motor shaft to retain the roller bearing.



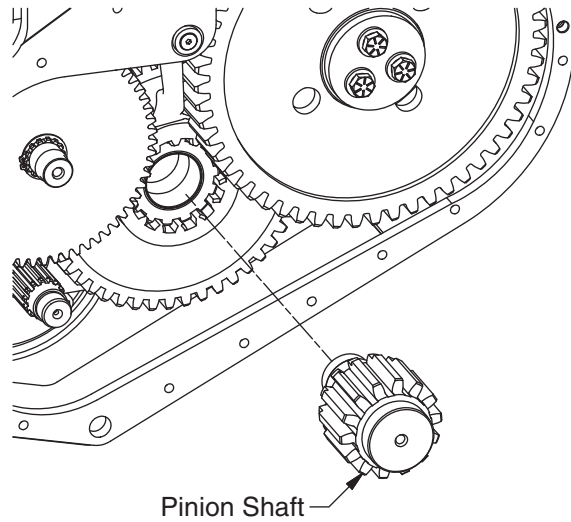
- Install inner support bearing for the idler shaft, and then the spacer, the idler shaft, and the internal pinion gears.



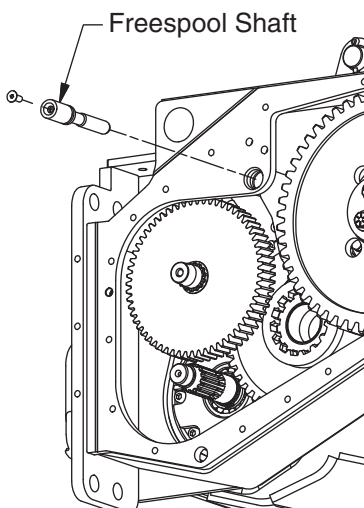
12. Install the intermediate gear, the dental clutch, and the freespool shift fork with the spring.



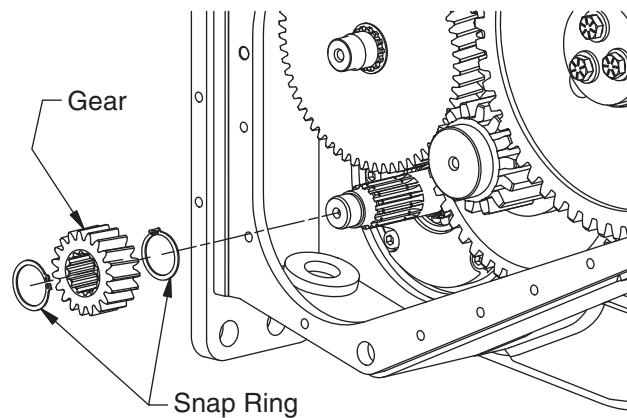
14. Install the pinion shaft.



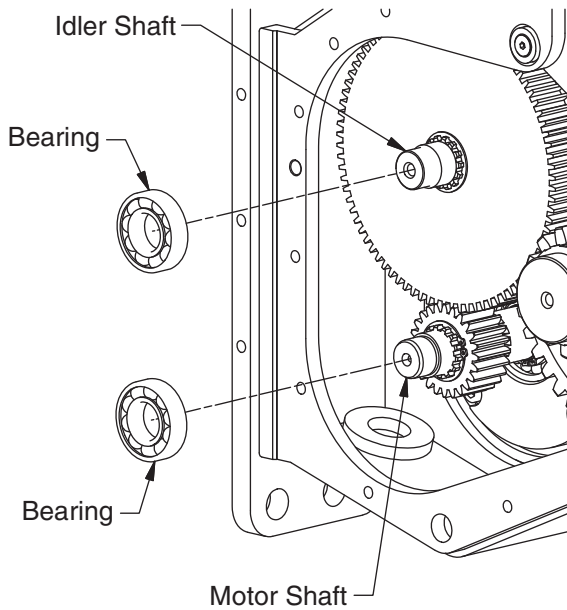
13. Install the freespool shaft and the capscrew. Reconnect the hydraulic hose from the shift fork to the fitting on the winch frame.



15. Install the gear on the motor shaft, install both snap rings.

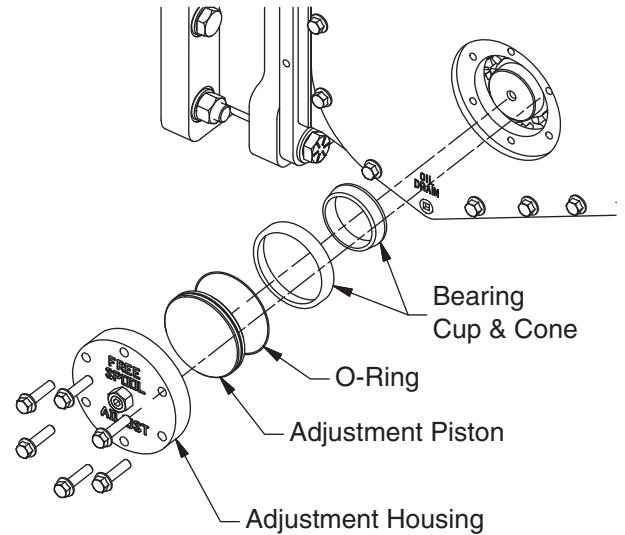


16. Position the bearings on the end of the motor and the idler shafts.

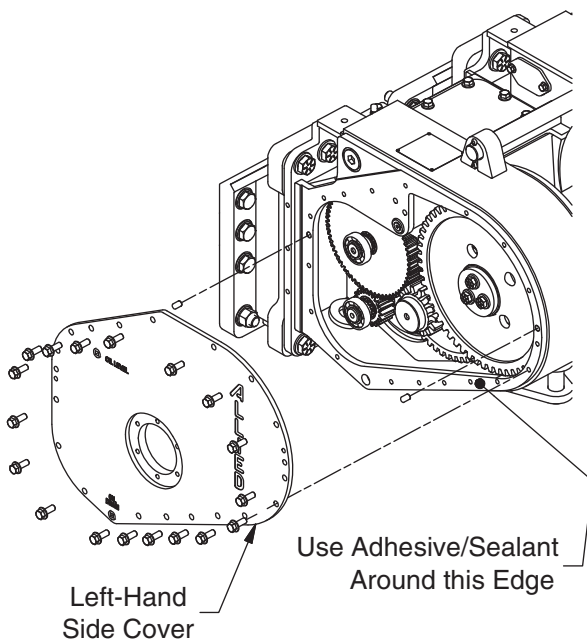


18. Install the freespool bearing (cone and cup). Inspect o-ring on freespool adjustment piston, and replace if damaged. Then, install freespool adjustment housing using adhesive/sealant. Torque capscrews to 80 LBS FT.

Note: Back adjustment screw out until there is no pressure on the piston. This will be adjusted when winch is mounted and on the tractor.

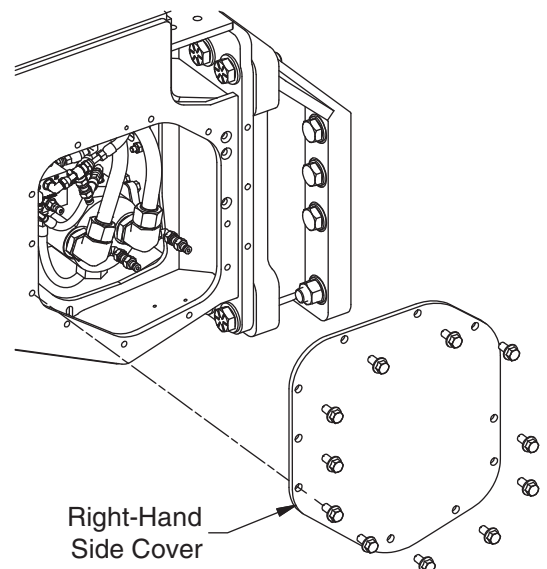


17. Using adhesive/sealant install the left hand frame cover. Torque capscrews to 80 LBS FT.



19. Refill the winch case with an approved oil listed in the service section of this manual up to the oil level port on the left side cover. Approximately 5-6 gallons. (To be verified by final assembly.)

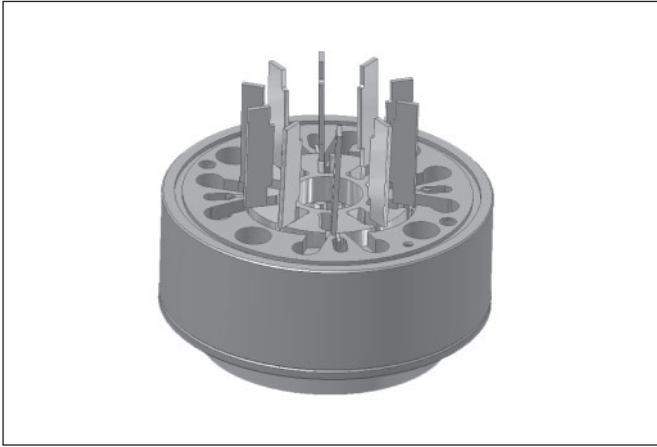
20. Install the right-hand side frame cover. Torque capscrews to 80 LBS FT.



Motor Assembly

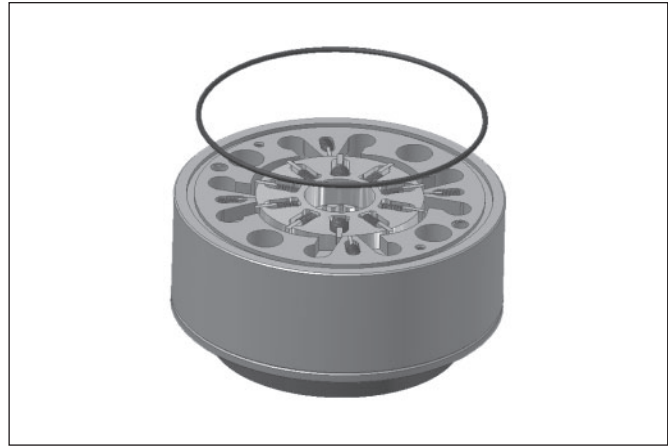
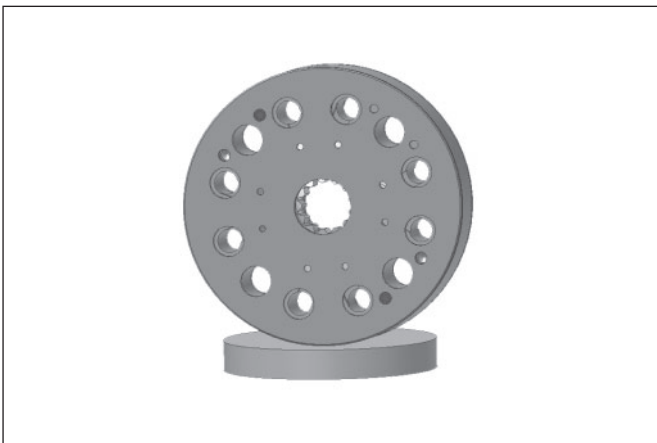
NOTE: Disassembling the motor while it's still under its warranty period immediately invalidates the warranty. If the motor malfunctions before its warranty period expires, please contact Allied Systems Company first before attempting to repair it.

1. Install the rotor and stator vanes. Install the rotor.



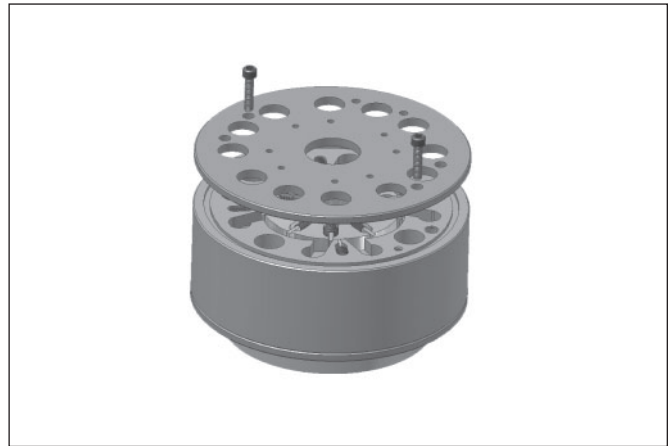
NOTE: Make sure that the radiused edge of each stator vane points to the rotor and the radiused edge of each rotor vane points to the stator.

2. Replace timing plate on rotor/stator cartridge. Install O-ring and springs, and install dowel pins. Turn plate over and repeat.



NOTE: Make sure springs are seated in the bottom of the spring pocket in both the rotor and stator.

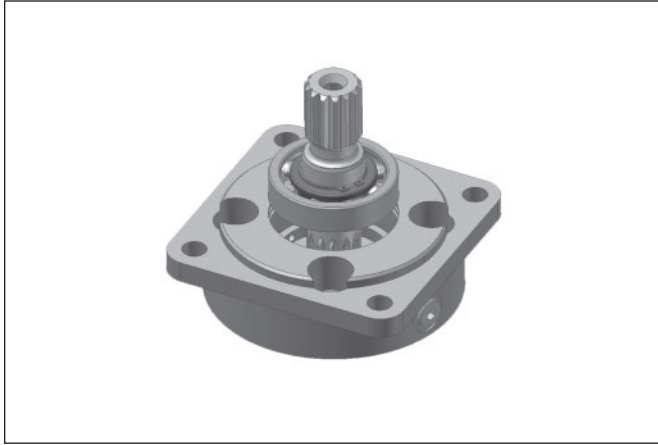
3. Place cartridge on any object which will hold it off the table. Install screws and timing plate.



4. Press bearing onto shaft. Install snap ring.

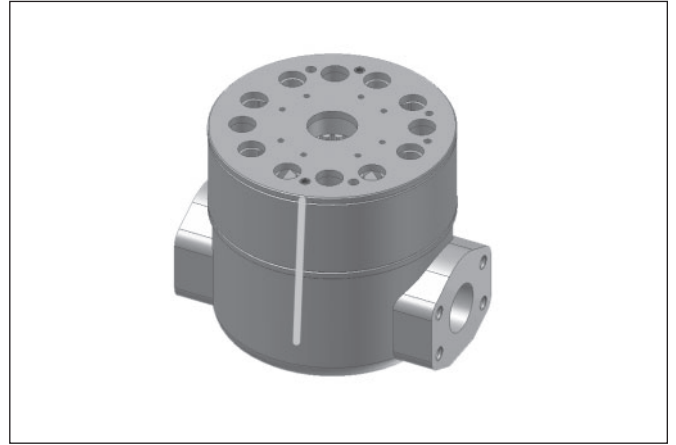


5. Press shaft and bearing assembly into front housing by pressing on the outer race of bearing.



8. Place rotor/stator cartridge onto rear housing.

NOTE: Make sure assembly marks from step 3 in the Motor Assembly section are lined up.



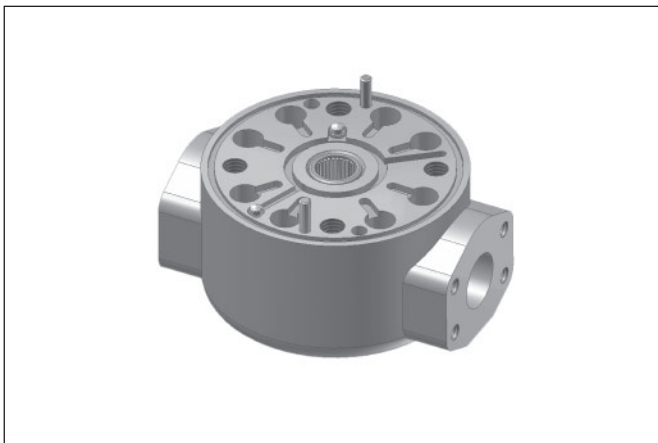
6. Place seal in seal plate. Place O-ring into groove in the front housing, then press seal plate into housing. Install snap ring.



9. Install main body O-ring and ball checks into front housing. Place a small amount of grease over ball checks and O-ring, then wipe off excess grease.



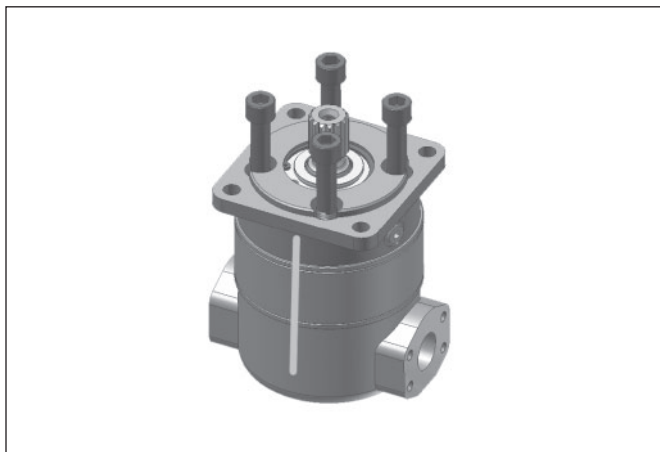
7. Install dowel pins and ballchecks into rear housing. Install main body O-ring.



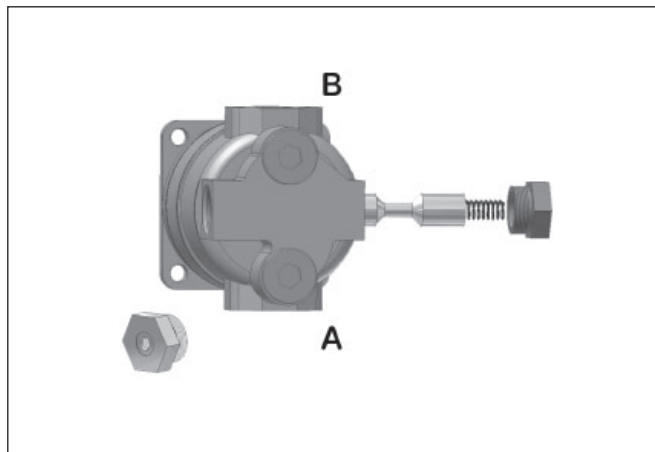
10. Install dowel pins into rotor/stator cartridge. Pour a small amount of clean oil into the cartridge, then install front housing. Make sure alignment marks are lined up.



11. Install 5/8-11 bolts. Torque bolts to 50 ft. lbs.



13. Reassemble the spool assembly. Ensure spool, spring and plug are oriented as shown for high-performance winches.



12. Rotate shaft in both directions to assure that the shaft turns smoothly. Torque motor to 190 ft. lbs. Rotate shaft again in both directions to assure that the shaft turns smoothly.

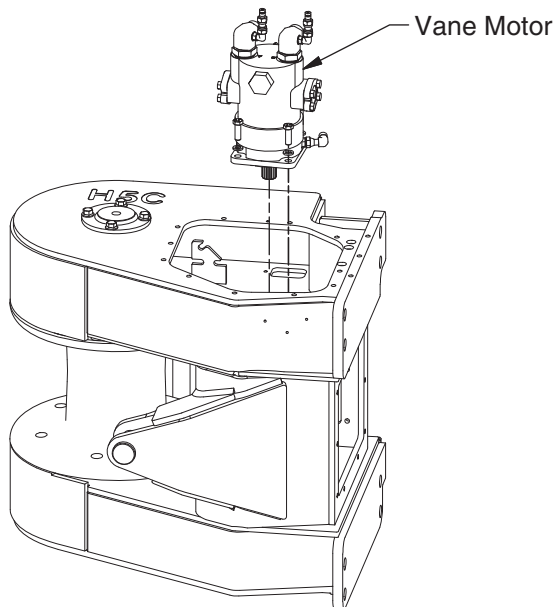


Intentionally Blank

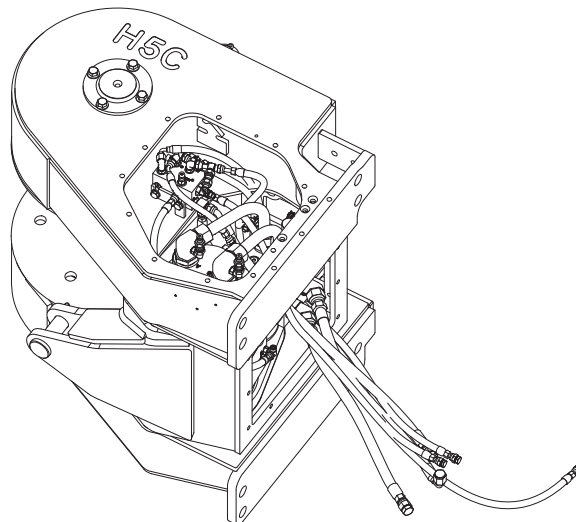
Motor Installation

Winches without optional DRAG-BRAKE

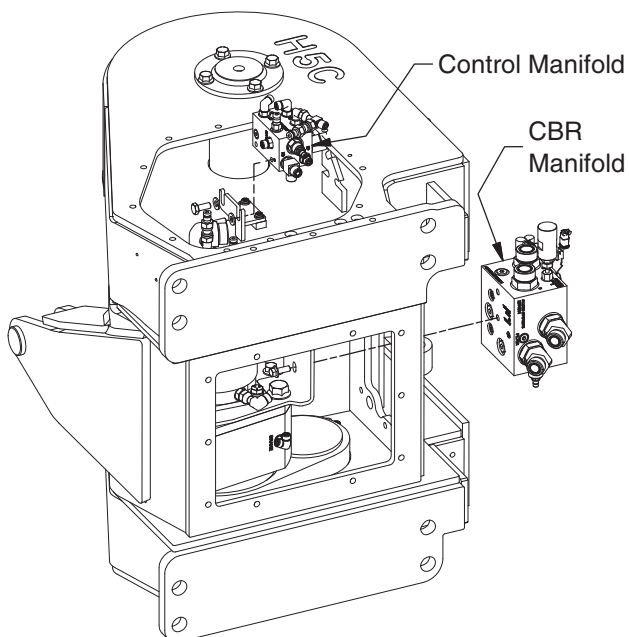
1. Using suitable lifting device position new motor in winch frame, in the same orientation as original motor. Install four fasteners in motor flange. 82 ft-lbs.



5. Install right-hand side cover and reposition winch to the upright position. Refill gear compartment with the proper oil, or remove installed pipe plug and reinstall breather.
6. Install winch on tractor and test for proper operation.



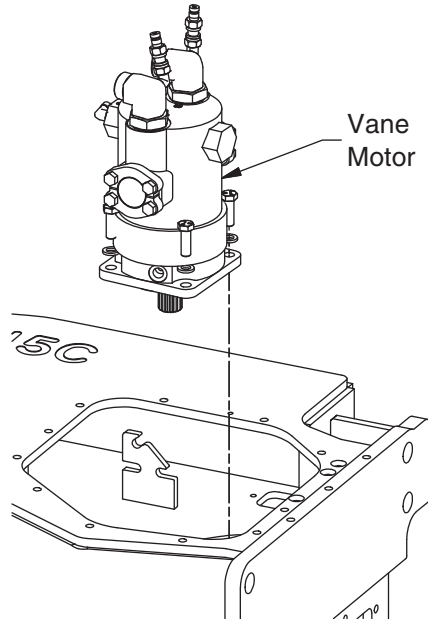
2. Reinstall CBR and control manifolds in their original positions and hand tighten fasteners only.
3. Reinstall all tube assemblies, hose assemblies, and wiring harnesses.
4. Tighten the fasteners used to mount the CBR and control manifolds. Use blue loc-tite on fasteners and tighten to 33 ft-lbs.



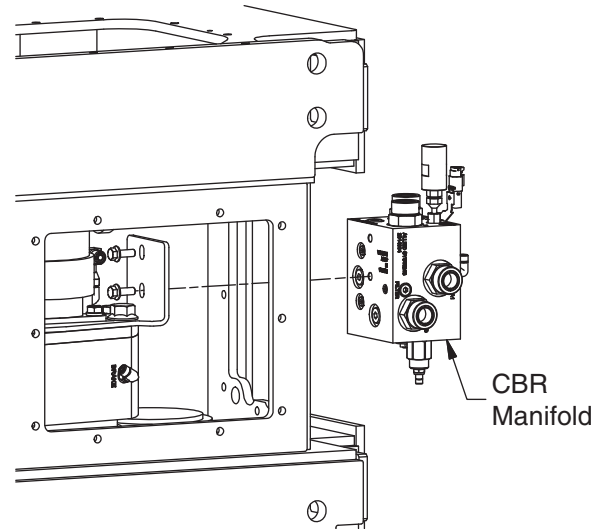
Motor Installation

Winches with optional DRAG-BRAKE

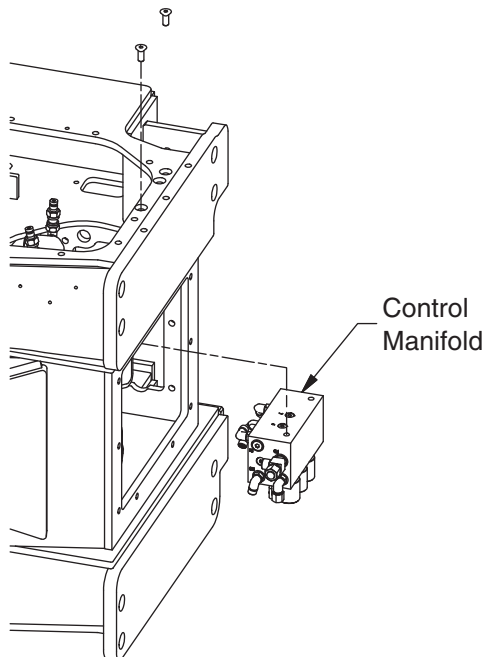
1. Using suitable lifting device position new motor in winch frame, in the same orientation as original motor. Install four fasteners in motor flange. 82 ft-lbs.



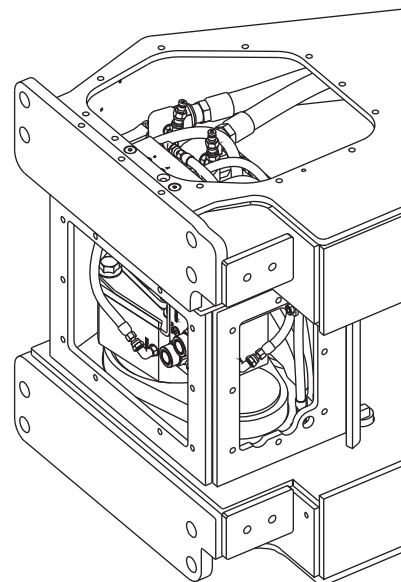
3. Reinstall CBR manifold in its original position and hand tighten fasteners only.
4. Reinstall all tube assemblies, hose assemblies, and wiring harnesses.
5. Tighten the fasteners used to mount the CBR and control manifolds. Use blue loc-tite on fasteners and tighten to 33 ft-lbs.



2. Reinstall control manifold in its original position and hand tighten fasteners only.



6. Install right-hand side cover and reposition winch to the upright position. Refill gear compartment with the proper oil, or remove installed pipe plug and reinstall breather.
7. Install winch on tractor and test for proper operation.



Winch Installation

1. Thoroughly clean the mounting surfaces on the winch and the tractor. Clean the mounting holes and hardware of dirt, grit and oil.
2. Attach sling or chain fall to lift points.
3. Raise the winch.



WARNING

Make sure the lifting device has a minimum rated capacity of 1,500 kg (3,500 lbs.) before lifting the winch.

4. Align the studs with the mounting holes to prevent thread damage.
5. Loosely install the two top nuts or capscrews before the winch is fully seated against the tractor.
6. Secure the winch in place using the parts listed in the mounting kit instructions. Tighten the nuts/capscrews alternately at each side of the winch to pull the winch evenly against the tractor.
7. Install control lever assembly per mounting kit instructions.



To find a dealer in your area,
Call: (503) 625-2560,
Fax: (503) 625-7269 , or
Email: marketing@alliedsystems.com, or
Visit our website: <http://www.alliedsystems.com>



599028W 1/3/2023 Printed in U.S.A.