



Allied Winches for Case Dozers

Options



Fairlead

Designed for maximum line pull from all angles. Strong vertical and horizontal rollers to reduce wire rope damage.



Drawbar

Provides an additional hitch for towing. Bolt-on drawbar optional on H4A. Built-in drawbar comes standard on all other models.



Integral Arch

Makes ground skidding easier by lifting butt-ends of logs.



Freespool

This disengages the drum from the gearing. Allows the winch line to be pulled out easily by hand. Standard on H4A, W5C, H5C and W6F winches.



Gearing

We offer a wide variety of gear ratios to meet different line speed requirements.



Electronic Controls

Simplifies winch installation and provides excellent line speed control.

Parts



Service Parts

World-class parts support. 98% same day fill rate. Orders received by 3 PM Pacific time shipped same day. Arrives at your office by 10am next day in the U.S. by special courier.



Allied Systems Company
21433 SW Oregon Street
Sherwood, OR 97140, USA
Phone: 503.625.2560
Fax: 503.625.7269 503.625.5132
marketing@alliedsystems.com
www.alliedsystems.com

Features

Hydraulic Winch Features

1. Simple "Plug and Play" installation – just bolt the winch to the tractor. No need for "winch ready" option on tractor.
2. Motor turns only on demand – less wear and tear, quiet operation.
3. Finger tip precision control – line speeds as fine as 0.5 ft/min (150 mm/min).
4. Large covers for easy service access.

PTO Winch Features

1. Simple "Plug and Play" installation – just bolt the winch to the tractor. No need for "winch ready" option on tractor.
2. SCH (Self Contained Hydraulics) – no exposed hydraulic lines.
3. Oil Clutch, Oil Brake – eliminates adjustments, runs cooler.
4. Large covers for easy service access.

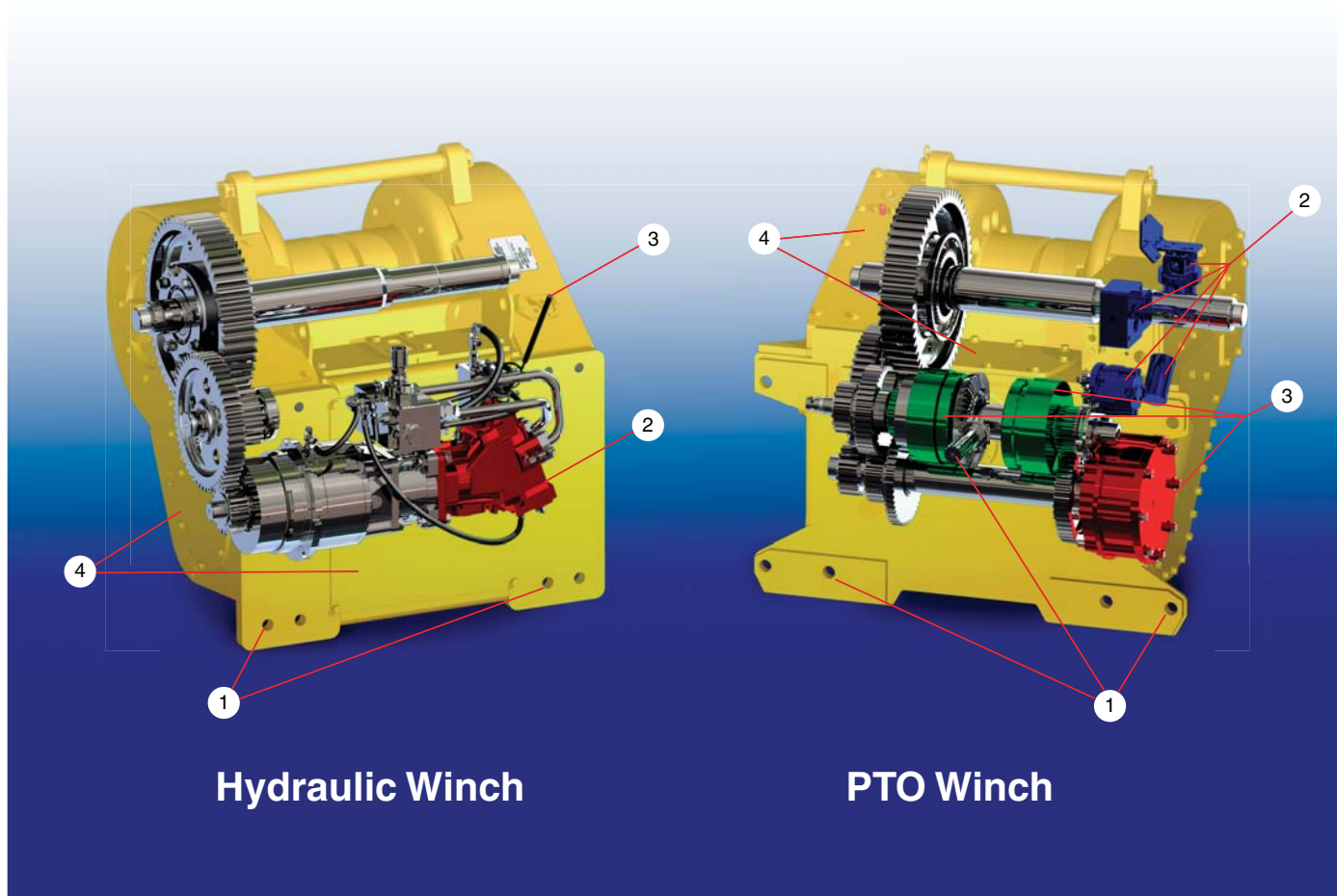

Hydraulic Winch

PTO Winch

ALLIED WINCHES FOR CASE DOZERS

TRACTOR MODEL*			650L	750M, 850M*	1150M	1650M	1650M	2050M	1850K	
(Specs based on representative model *, others similar)										
WINCH MODEL			H4AH	H4AH	H5CT	H5CT	H6HT	H6HT	W6G	
WINCH TYPE: Hydraulic or Power Take-Off			HYD	HYD	HYD	HYD	HYD	HYD	PTO	
STANDARD GEAR RATIO			94:1	94:1	48:1	48:1	153:1	153:1	83:1	
Unit										
S T A N D A R D	BARE DRUM	Maximum Line Pull**	lbs (kg)	38,650 (17,531)	38,650 (17,531)	61,150 (27,737)	61,150 (27,737)	78,900 (35,788)	88,800 (40,279)	88,800 (40,279)
		Approximate Line Speed @	fpm (mpm)	78 (24)	78 (24)	25 (8)	35 (11)	44 (13)	63 (19)	56 (17)
		Typical Working Load of	lbs (kg)	20,000 (9,072)	20,000 (9,072)	30,000 (13,608)	30,000 (13,608)	40,000 (18,144)	40,000 (18,144)	40,000 (18,144)
D A R D	FULL DRUM	Maximum Line Pull**	lbs (kg)	21,600 (9,798)	21,600 (9,798)	32,950 (14,946)	32,950 (14,946)	42,350 (19,210)	51,250 (23,247)	88,800 (40,279)
		Approximate Line Speed @	fpm (mpm)	89 (27)	89 (27)	47 (14)	65 (20)	48 (15)	66 (20)	101 (31)
		Typical Working Load of	lbs (kg)	20,000 (9,072)	20,000 (9,072)	30,000 (13,608)	30,000 (13,608)	40,000 (18,144)	40,000 (18,144)	40,000 (18,144)
		Maximum Line Speed	fpm (mpm)	149 (45)	149 (45)	91 (28)	126 (38)	133 (41)	149 (45)	139 (42)

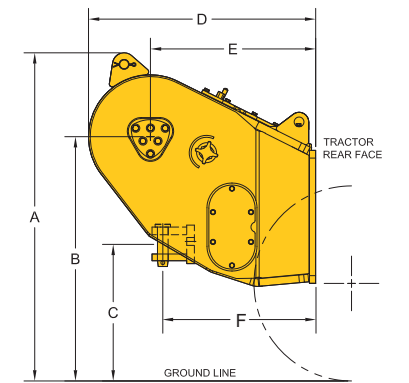

H4A

O P T I O N A L	MAXIMUM LINE SPEED BARE DRUM USING OPTIONAL GEAR RATIO	Shaded ratios not available for this model	45/1	fpm (mpm)						140 (43)	
			56/1	fpm (mpm)							
			100/1	fpm (mpm)							
			103/1	fpm (mpm)							60 (18)
			153/1	fpm (mpm)							

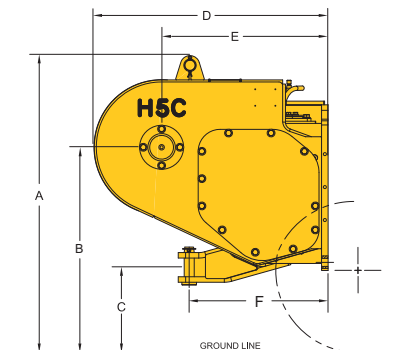

H5C

D I M E N S I O N A L D A T A	See illustrations	A	Ground to highest point	in (mm)	46 (1,168)	46 (1,168)	47 (1,194)	47 (1,194)	51 (1,295)	53 (1,346)	57 (1,448)
		B	Ground to drum center	in (mm)	35 (889)	35 (889)	34 (864)	34 (864)	37 (940)	39 (991)	43 (1,092)
		C	Ground to drawbar center	in (mm)	21 (533)	21 (533)	18 (457)	18 (457)	18 (457)	20 (508)	24 (610)
		D	Dozer face to end of winch	in (mm)	35 (889)	39 (991)	35 (889)	35 (889)	39 (991)	39 (991)	40 (1,016)
		E	Dozer face to drum center	in (mm)	27 (686)	31 (787)	25 (635)	25 (635)	29 (737)	29 (737)	29 (737)
		F	Dozer face to drawbar center	in (mm)	25 (635)	29 (737)	22 (559)	22 (559)	28 (711)	28 (711)	28 (711)
		G	Winch max. width (not shown)	in (mm)	31 (787)	31 (787)	32 (813)	32 (813)	40 (1,016)	40 (1,016)	38 (965)

S H I P P I N G W E I G H T S	Shaded options not available	Winch, approx. w/o wire rope	lbs (kg)	1,680 (762)	1,680 (762)	2,100 (953)	2,100 (953)	2,900 (1,315)	2,900 (1,315)	2,900 (1,315)
		Fairlead	lbs (kg)	310 (141)	310 (141)	450 (204)	450 (204)	875 (397)	875 (397)	875 (397)
		Drawbar	lbs (kg)	30 (14)	30 (14)	w/winch	w/winch	w/winch	w/winch	w/winch
		Integral Arch	lbs (kg)	420 (191)	420 (191)	875 (397)	875 (397)	1,100 (499)	1,100 (499)	1,100 (499)

W I R E R O P E C A P A C I T Y	Shaded sizes not available Capacity per SAE J1158	WINCH MODEL	Barrel Diameter	WIRE ROPE DIAMETER					
				1/2 in. (13 mm.)	5/8 in. (16 mm.)	3/4 in. (19 mm.)	7/8 in. (22 mm.)	1 in. (25 mm.)	
		H4A	8 in. (203 mm.)	422 ft. (129 m)					
		H5C	8.56 in. (217 mm.)		423 ft. (129 m)	298 ft. (91 m)	215 ft. (66 m)		
		W6G	10.00 in. (254 mm.)			376 ft. (115 m)	271 ft. (83 m)	210 ft. (64 m)	
H6H	10.00 in. (254 mm.)			413 ft. (126 m)	297 ft. (91 m)	230 ft. (70 m)			

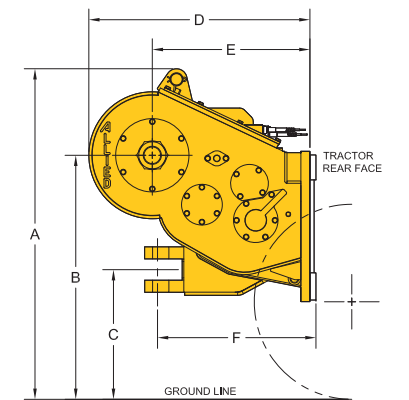

H6H/W6G

Notes:
 **Maximum line pull is the lesser of the maximum line pull that the tractor will develop with the standard gear ratio or the breaking strength for the maximum recommended wire rope for that winch model.
 Allied Systems Company reserves the right to change and/or improve specifications and performance at its own discretion without prior notice. Check with dealer for latest data.