

Allied H4A Winch for John Deere 450, 550, 650, and 700 Dozers

- Smooth speed control. No shock load.
- “Plug and Play” easy installation.
- Powerful



Advantages:

- Infinitely variable speed - from creeping to full speed control with single lever movement. Smooth operation. No shock load.
- Self-Contained Hydraulic (SCH) design. All hydraulic components contained inside winch frame for integrity and protection. Just bolt the winch to dozer for simple “Plug and Play” installation.
- Winch pump is PTO-driven, hydraulically controlled. Full PTO horsepower available to winch for powerful line pull.
- Simplified inventory control. Same H4A winch fits all JD 450, 550, 650 “J” and “K” series dozers. Simple mounting conversion to JD 700 “H”, “J” and “K” series dozers.
- Large covers for easy service access.
- Winch comes standard with power-in, power-out and freespool.
- Easy bolt-on options:
 - Adjustable 4-Roller Arch
 - 4-Roller Fairlead
 - Drawbar

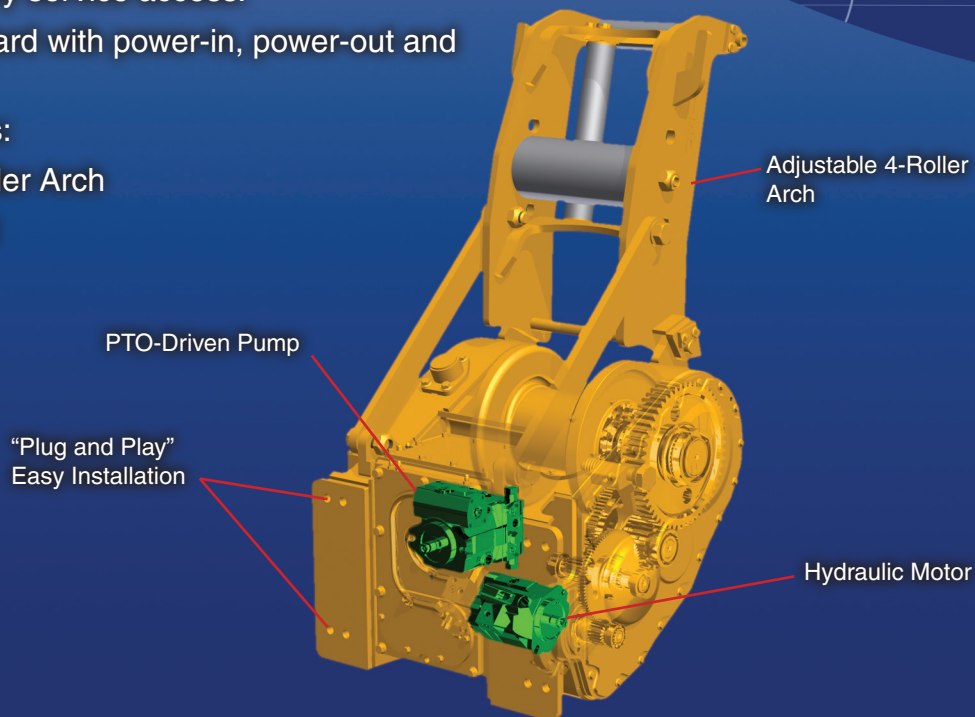

Building the world's most technologically advanced winches

Specifications

H4A Winch for John Deere 450, 550, 650, and 700 Dozers

Performance



		Winch Model:	H4A	
		Tractor Models:	450-550-650 J/K 700 H/J/K	
Bare Drum	Maximum Line Pull	lbs (kg)	38,200 (17,327)	
	Line Speed @	fpm (mpm)	78 (24)	
	Typical Working Load of	lbs (kg)	20,000 (9,072)	
	Maximum Line Speed	fpm (mpm)	83 (25)	
Full Drum	Maximum Line Pull	lbs (kg)	21,300 (9,662)	
	Line Speed @	fpm (mpm)	52 (16)	
	Typical Working Load of	lbs (kg)	20,000 (9,072)	
	Maximum Line Speed	fpm (mpm)	149 (45)	
Weight (approximate)	Winch w/o wire rope	lbs (kg)	1,680 (762)	
	Fairlead (optional)	lbs (kg)	310 (141)	
	Drawbar (optional)	lbs (kg)	30 (14)	
	Integral Arch (optional)	lbs (kg)	420 (191)	
Wire Rope Capacity	Barrel Diameter	in (mm)	8.00 (203)	
	Wire Rope Diameter	1/2 (13) ft (m)	422 (129)	
		5/8 (16) ft (m)	277 (84)	
		3/4 (19) ft (m)	195 (59)	
	Ferrule	Name	Bantam	
		Length	in (mm)	2 (51)
Diameter		in (mm)	1.5 (38)	
Dimensional Data (see illustration)	A	Ground to highest point	in (mm)	46 (1,168)
	B	Ground to drum center	in (mm)	35 (889)
	C	Ground to drawbar center	in (mm)	20 (508)
	D	Dozer face to end of winch	in (mm)	36 (914)
	E	Dozer face to drum center	in (mm)	28 (711)
	F	Dozer face to drawbar center	in (mm)	27 (686)
	G	Winch max width (not shown)	in (mm)	31 (787)

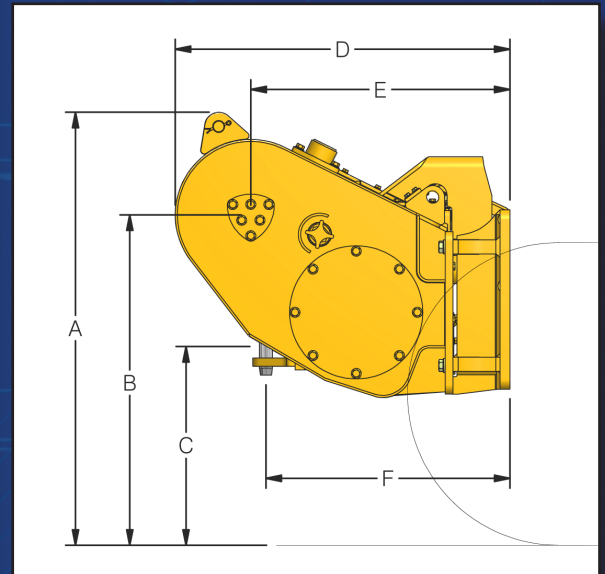

Allied Systems Company
 21433 SW Oregon St
 Sherwood, OR 97140 USA
 503.625.2560
www.alliedsystems.com
marketing@alliedsystems.com

