

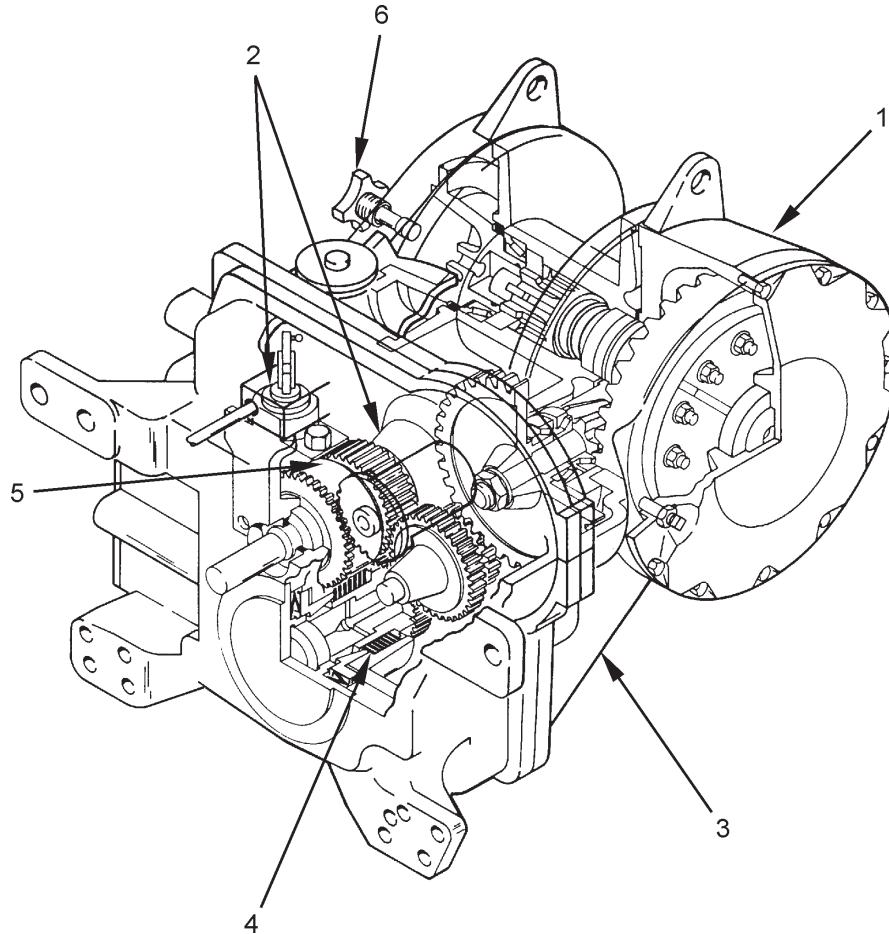

ALLIED W3C WINCH FOR NEW HOLLAND DC75, DC85 & DC95 CRAWLER DOZERS



Features

- 1. FLUSH DRUM**
Drum flush with frame to reduce line wear from side pulls.
- 2. SELF-CONTAINED HYDRAULICS (SCH)**
Valve, pump, filter and hydraulic lines are inside winch for long component life and simplified winch installation.
- 3. HEAVY-DUTY FRAME**
Protects, and allows easy access to internal components.
- 4. OIL BRAKE**
Spring applied, multiple-disc hydraulically released and oil cooled for long life. No heat fade. Eliminates routine adjustments.
- 5. MULTI-DISC CLUTCH**
Hydraulically applied clutch is automatically synchronized with the oil brake for smooth winch line control.
- 6. FREESPOOL**
Standard freespool disconnects drum from gearing to allow wire rope to be pulled out by hand. Adjustable drag is standard.

Performance & Specifications

		DC95	DC85	DC75
Bare Drum	Max. Line Pull (lbs)	41,800	40,300	34,800
	Line Speed @ 12,000 lbs	88 fpm	87 fpm	87 fpm
	Max. Line Speed	91 fpm	91 fpm	91 fpm
Full Drum	Max. Line Pull (lbs)	24,000	23,100	18,900
	Line Speed @ 12,000 lbs	149 fpm	148 fpm	147 fpm
	Max. Line Speed	158 fpm	158 fpm	158 fpm

Drum Size

Barrel diameter 8.00 in.
 Barrel length 7.62 in.
 Flange diameter 16.02 in.

Drum Capacity

5/8" wire rope 232 ft.
 3/4" wire rope 164 ft.
 (capacity may be less if wire rope is not tightly and evenly spooled.)

Ferrule Size

	Type	Length	Diameter
5/8" wire rope	B5	2 in.	1.5 in.
3/4" wire rope	B5	2 in.	1.5 in.

Weight

Winch, without wire rope approx. 1250 lbs.

Dimensional Data

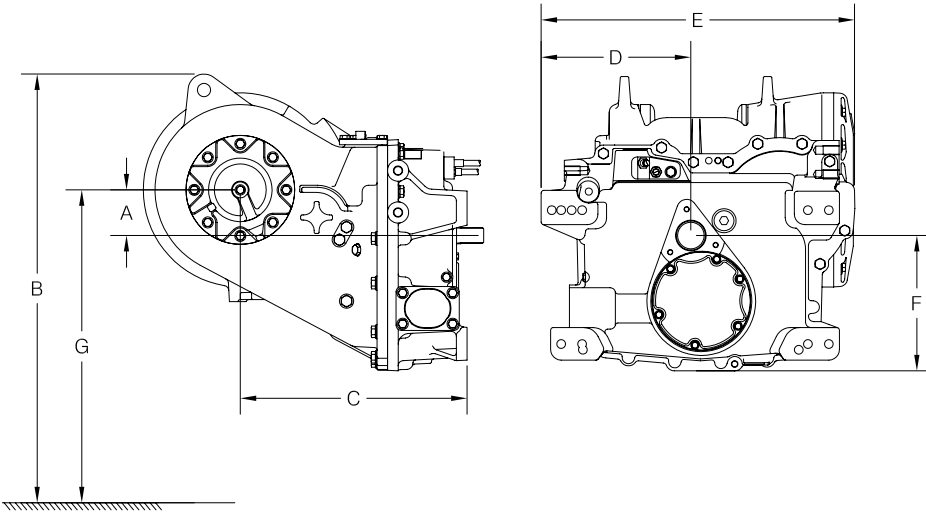

Dimensions

A 4.29 in.
 B 42.00 in.
 C 27.00 in.
 D 14.00 in.
 E 29.56 in.
 F 12.68 in.
 G 31.00 in.

Options

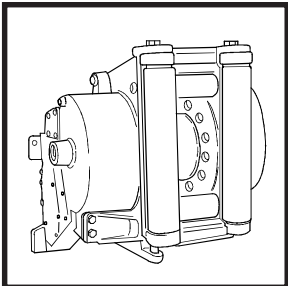

FAIRLEAD

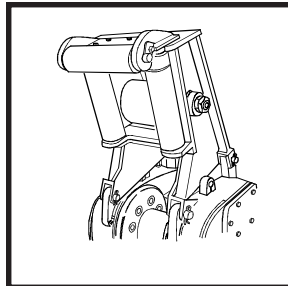

ARCH

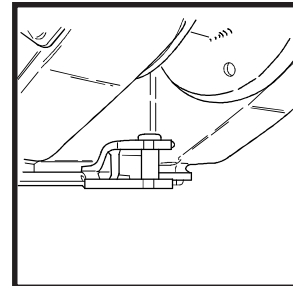

DRAWBAR

Allied Systems
 COMPANY

2300 Oregon Street
 Sherwood, OR 97140 USA
 ph: 503.625.2560
 fx: 503.625.7269
www.alliedsystems.com
marketing@alliedsystems.com

DISTRIBUTED BY: