Electrical System, Cummins

Electrical System, Cummins

Item	Part No.	Qty	Description	Item	Part No.	Qty	Description
	602040		Electrical System, Cummins				
1	602119	1	. Wire Harness, "A" Chassis	9.23	R13801840	1	.. Capscrew
	237172	3	.. Resistor, 1K Ohm	9.24	R13801760	2	.. Fitting
	241893	1	.. Resistor, 18K Ohm	9.25	R13801782	1	.. Capscrew
2	602120	1	. Wire Harness, "B" Chassis	9.99	602194	1	.. Battery Harness
	237172	2	.. Resistor, 1K Ohm	9.99.1			... Battery Cable "A"
3	602121	1	. Wire Harness, "C" Chassis	9.99.2			... Battery Cable "C"
	594744	1	.. Capacitor, 4 Pin	9.99.3			... Battery Cable "B"
4	602122	1	. Wire Harness, "D" Chassis	9.99.4			... Battery Cable "D"
	594742	2	.. Capacitor, 2 Pin	9.99.5			... Battery Cable "E"
5	599843	1	. Harness, After Treatment	9.99.6			... Battery Cable "F"
6	602124	1	. Wire Harness, Engine	9.99.7			... Battery Cable "G"
	597377	5	.. Relay, Micro, 24V Spdt	9.99.8			... Battery Cable "H"
	597379	2	.. Fuse, Auto Mini, 10Amp	9.99.9			... Battery Cable "J"
	597380	1	.. Fuse, Auto Mini, 15Amp	9.99.10			... Battery Cable "D"
	597382	1	.. Fuse, Auto Mini, 30Amp	9.99.11			... Battery Cable "M"
7	598644	1	. Linear Position Sensor	9.99.12			... Battery Cable "N"
	598911	1	.. Kit, Spherical Rod Ends	10	593637	1	. Horn , Dual Trumpet
8	597233	1	. Sending Unit, Fuel	11	* R19361	1	. Alarm, Reverse
9	602193	1	. Inst, Battery Harness, Cummins	12	Y25G-(1024)08	1	. Capscrew
9.1	200220	2	.. Battery	13	595326	A/R	. Mount, Tack
9.2	246927	1	.. Switch, Battery Disconnect	14	249329	A/R	. Cable Tie
9.3	601714	1	.. Fuse Holder, Anl	15	R13801359	1	. Clip, Insulated
9.4	601715-750	1	.. Fuse, Anl	16	209578	1	. Clamp
9.5	601743	1	.. Battery Mount	17	Y35E-#10	2	. Washer
9.6	601723	2	.. J-Bolt	18	603606	2	. Bracket, Harness Mount
9.7	583417	2	.. Pad	19	302401W	1	. Locknut
9.10	585189	1	.. Battery Lockout Installation	20	2311550	3	. Clip, Harness Mounting
9.11	249329	6	.. Cable Tie	22	221767W	8	. Washer
9.12	221767W	2	.. Washer	23	237567	4	. Locknut
9.13	237567	2	.. Locknut	24	221499W	4	. Capscrew
9.14	231537	12	.. Clamp	25	293628W	1	. Capscrew
9.15	221763W	10	.. Washer	27	293631W	1	. Capscrew
9.16	15113W	4	.. Locknut	28	603551	1	. Bracket, Fuel Level Guard
9.17	R13801783	4	.. Capscrew	29	R13808094	5	. Clip, Insulated
9.18	R13811190	2	.. Locknut	30	296420W	3	. Washer
9.19	R13802914	4	.. Washer	31	296422W	2	. Washer
9.20	R13811015	2	.. Capscrew	32	R13811225	2	. Capscrew
9.21	231252	3	.. Clamp	33	599855	1	. Bracket Assembly
9.22	221771W	1	.. Washer	34	599797	1	. Boot Connector

* See Separate Coverage

2. ROUTE WIRE HARNESS AS SHOWN. DEVIATION FROM THIS ROUTING WILL AFFECT HARNESS LENGTHS.
 -WIRE HARNESS SHALL BE SUPPORTED EVERY 18 INCHES AS REQUIRED WITH TACK MOUNTS AND CABLE TIES.
 -WHEN SECURING WIRES HARNESS TO TACK MOUNT, RUN CABLE TIE THROUGH BOTH TACK MOUNT LOOPS AND STRADDLE HARNESS IN TACK MOUNT.
 -WHEN NOT SECURING HARNESS TO TACK MOUNT, USE THE FIRST LOOP TO SECURE CABLE TIE TO SUPPORT OBJECT, THEN USE THE SECOND LOOP TO SECURE THE WIRE HARNESS.

3. THIS COMPONENT IS NOT USED ON THE LC90.

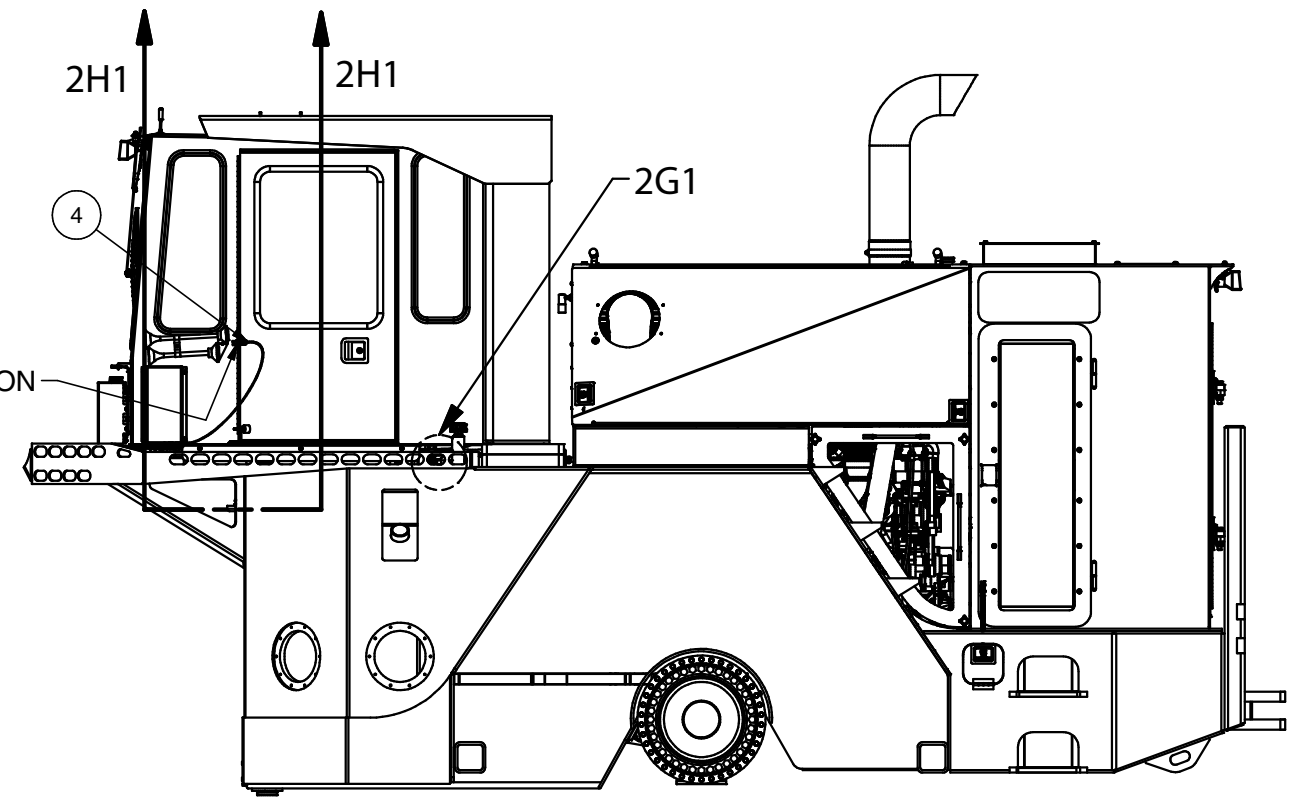
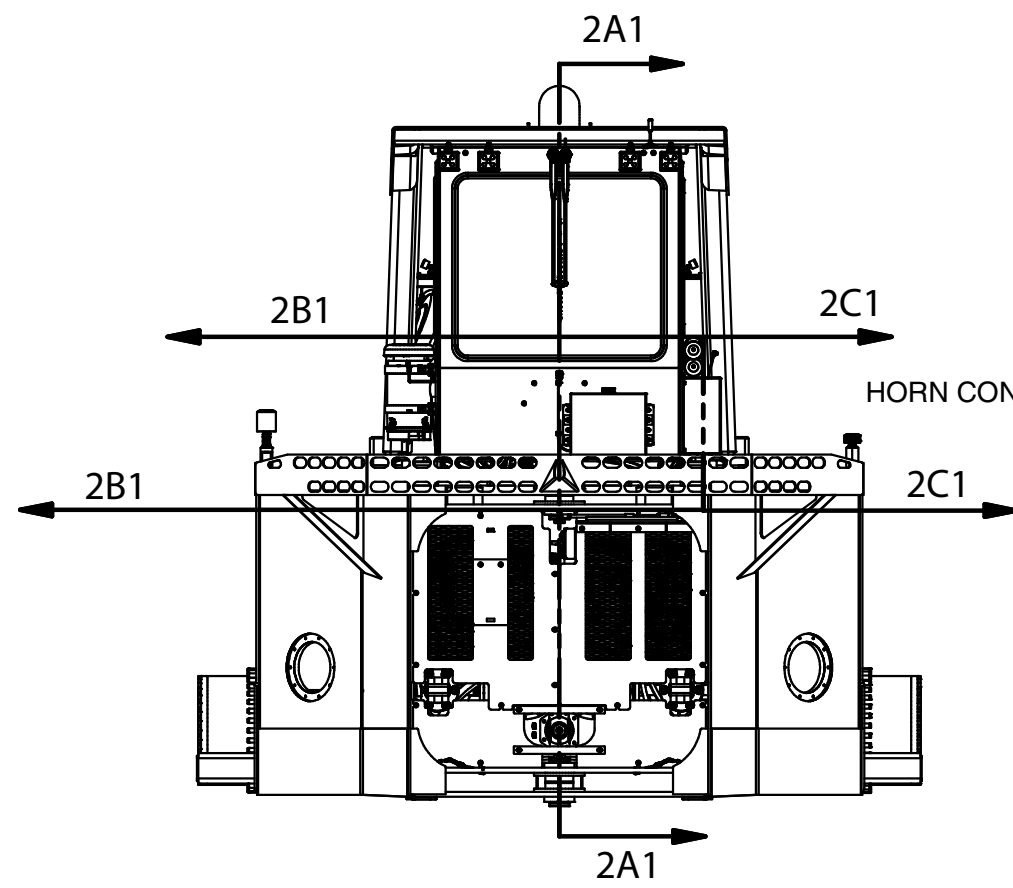
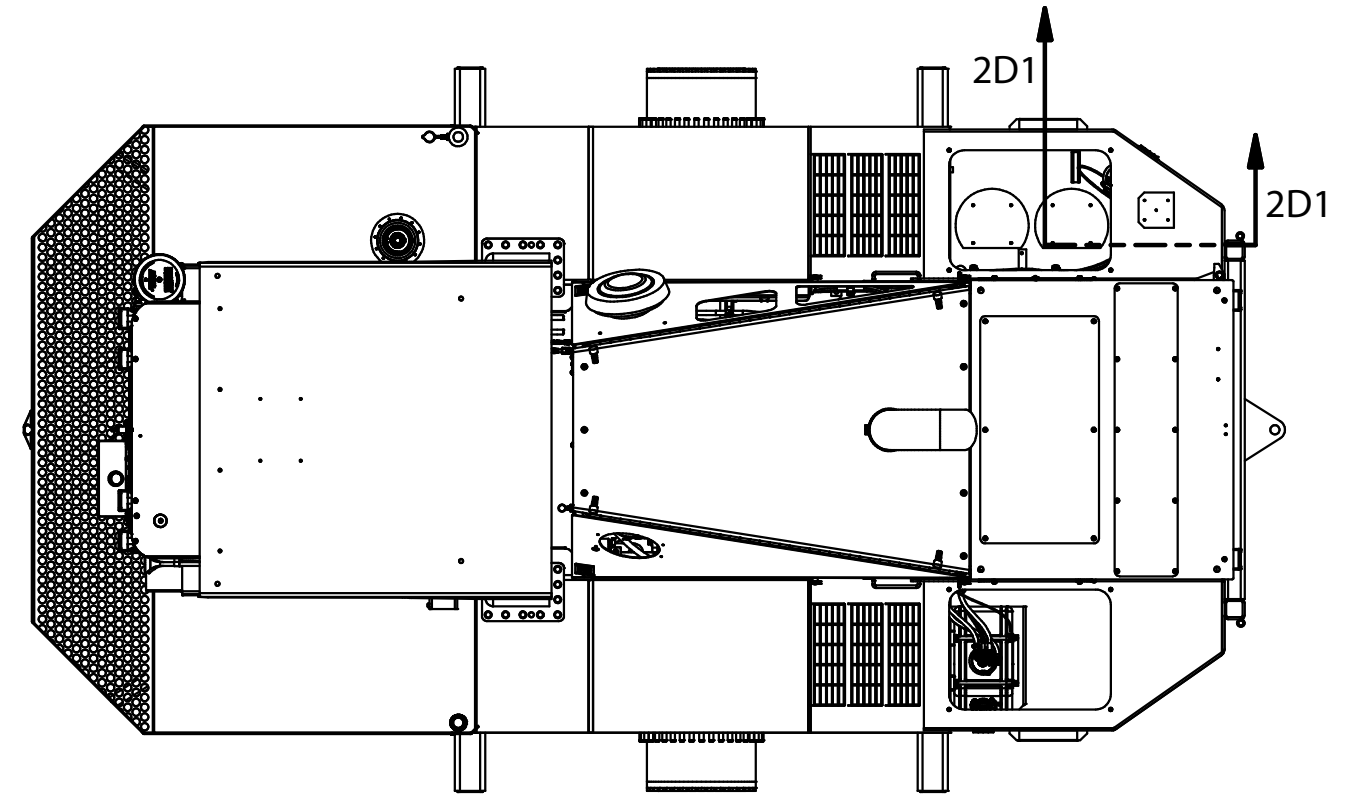

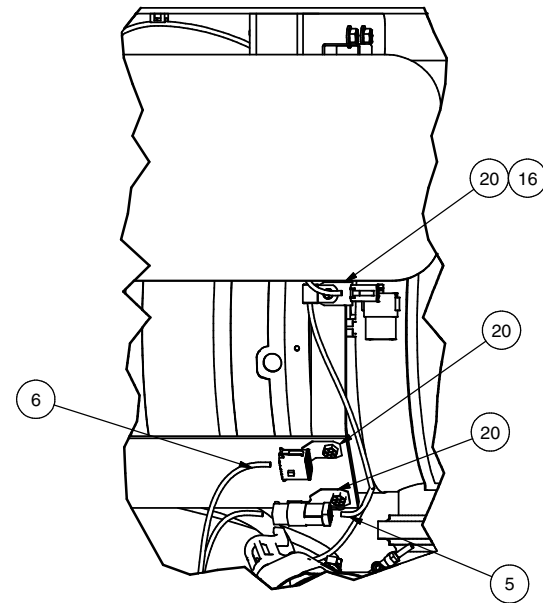

DETAIL 2F2

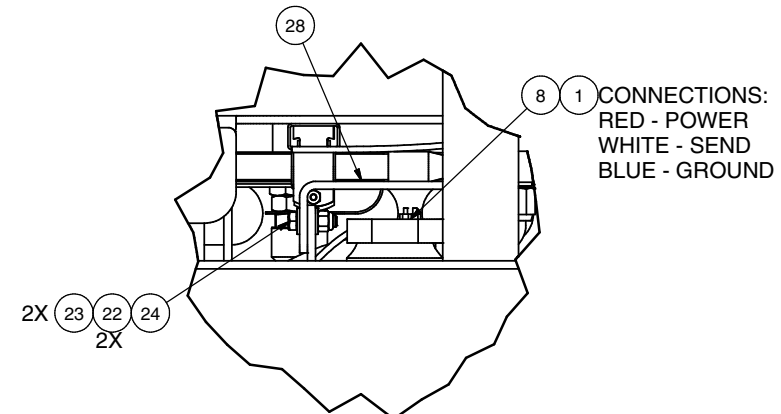

DETAIL 2G1
FUEL LEVEL SENSOR
PARTS HIDDEN FOR CLARITY

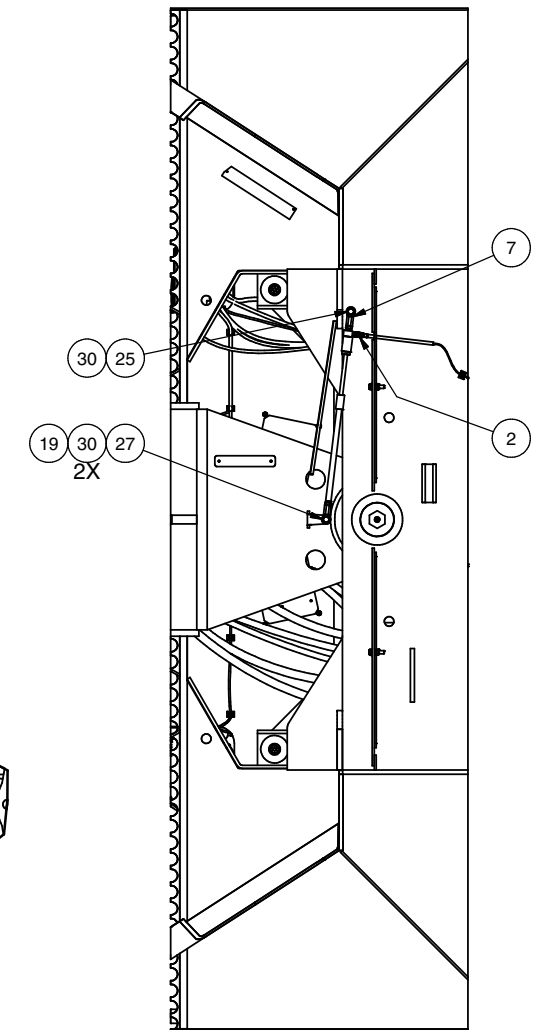

SECTION 2H1-2H1
STEERING POSITION SENSOR

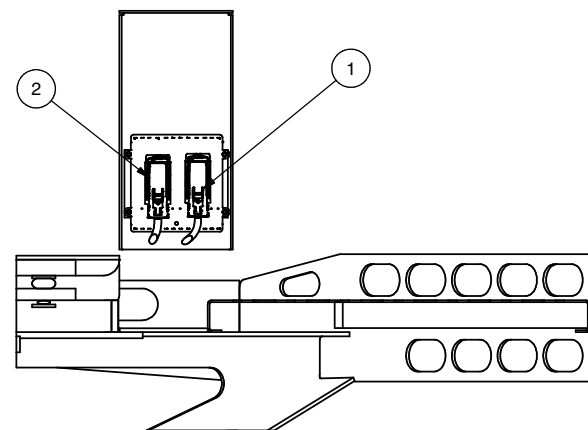

SECTION 2C1-2C1
CAB ELECTRICAL BOX
VIEW CROPPED FOR CLARITY

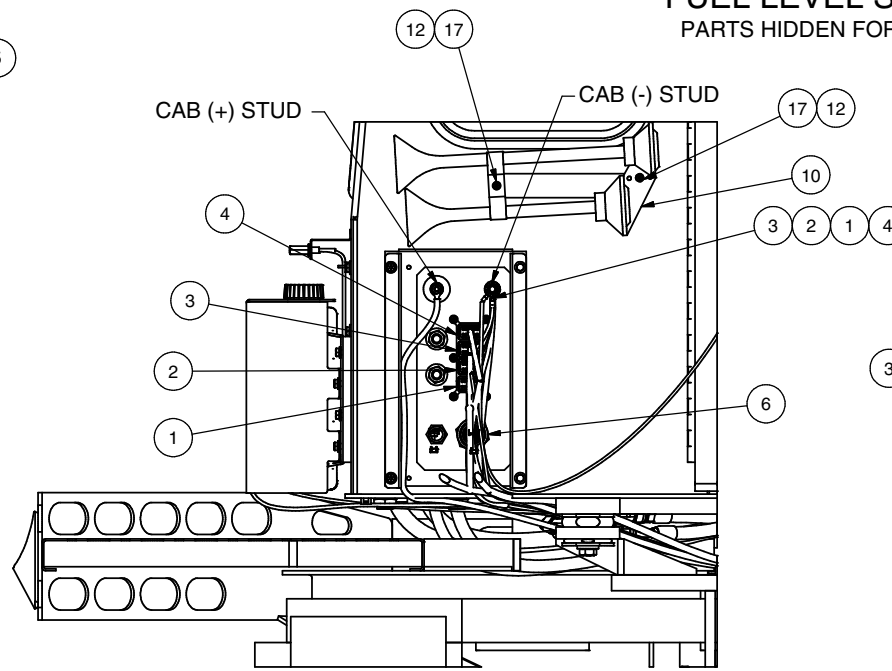

SECTION 2B1-2B1
CAB ELECTRICAL BULKHEAD
AND HORN LOCATION
VIEW CROPPED FOR CLARITY

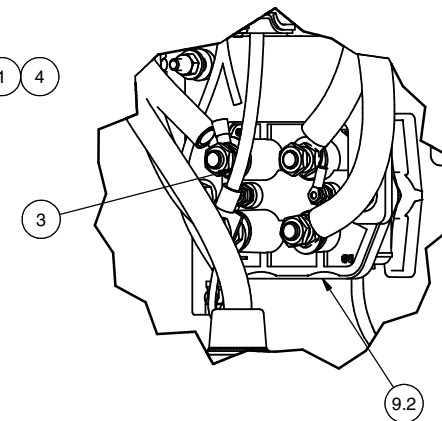

DETAIL 2E2
BATTERY SWITCH

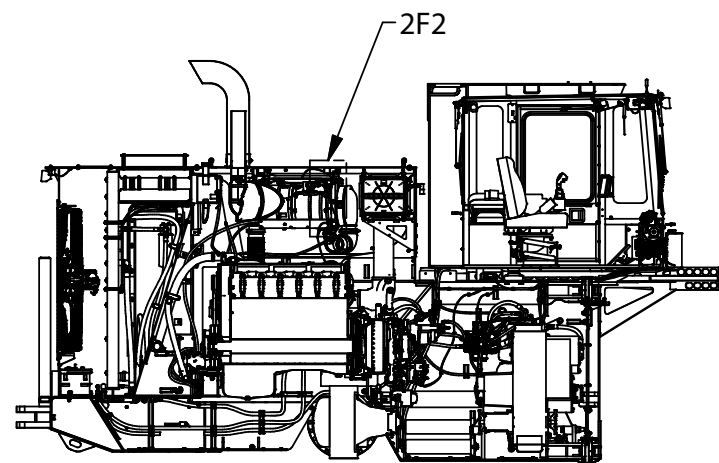

SECTION 2A1-2A1

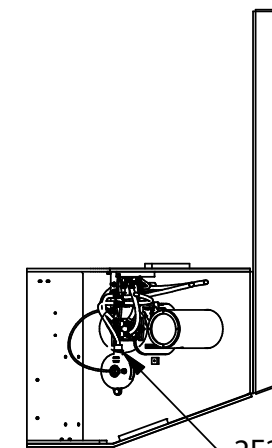

SECTION 2D1-2D1

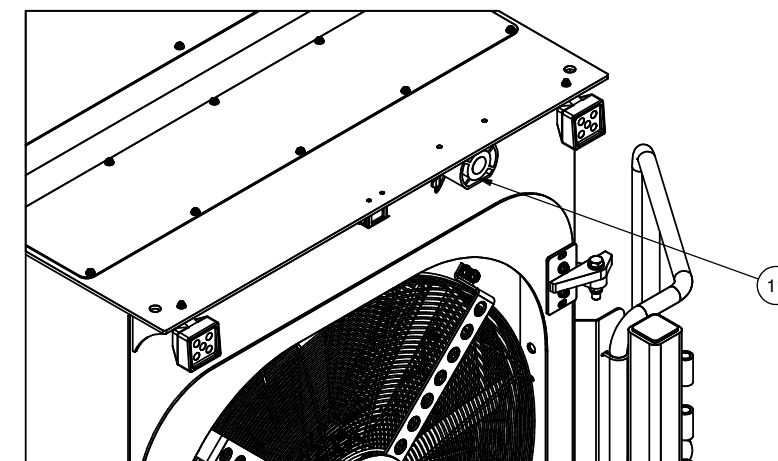

REAR HOOD

CHASSIS HARNESS "A"

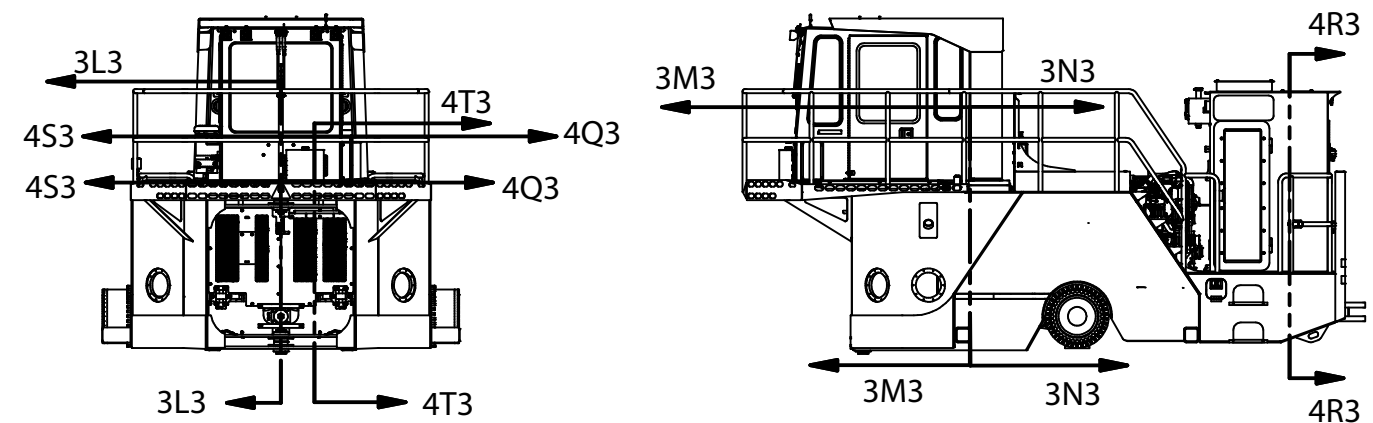
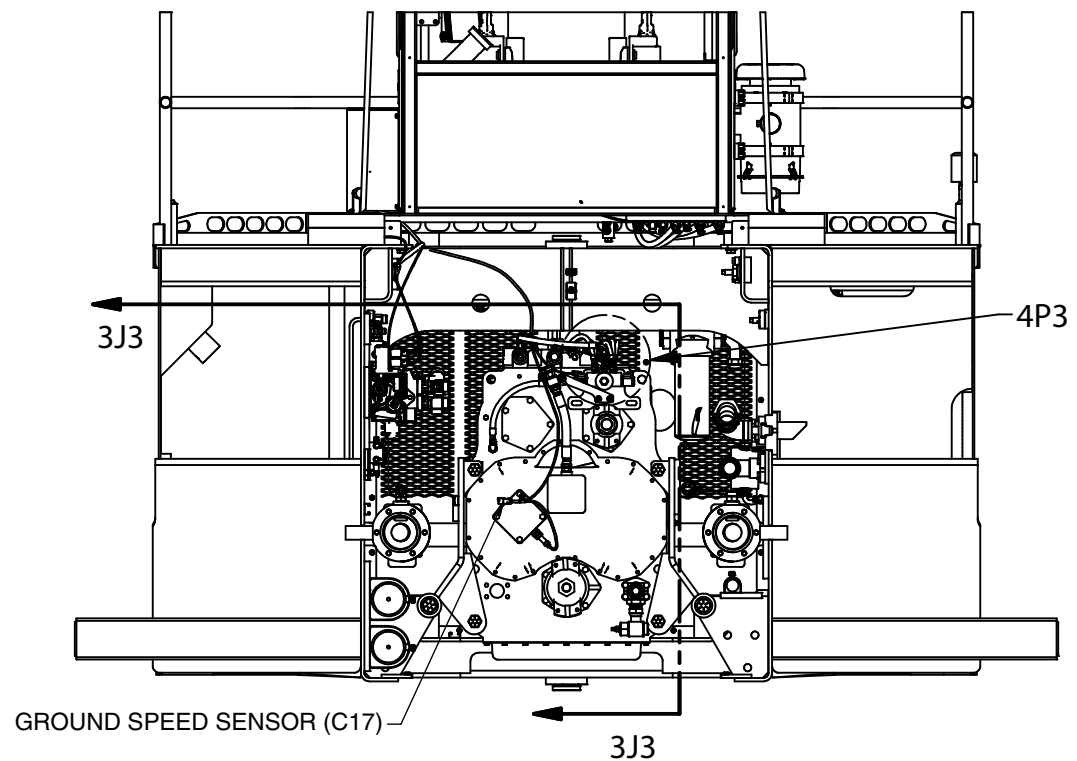
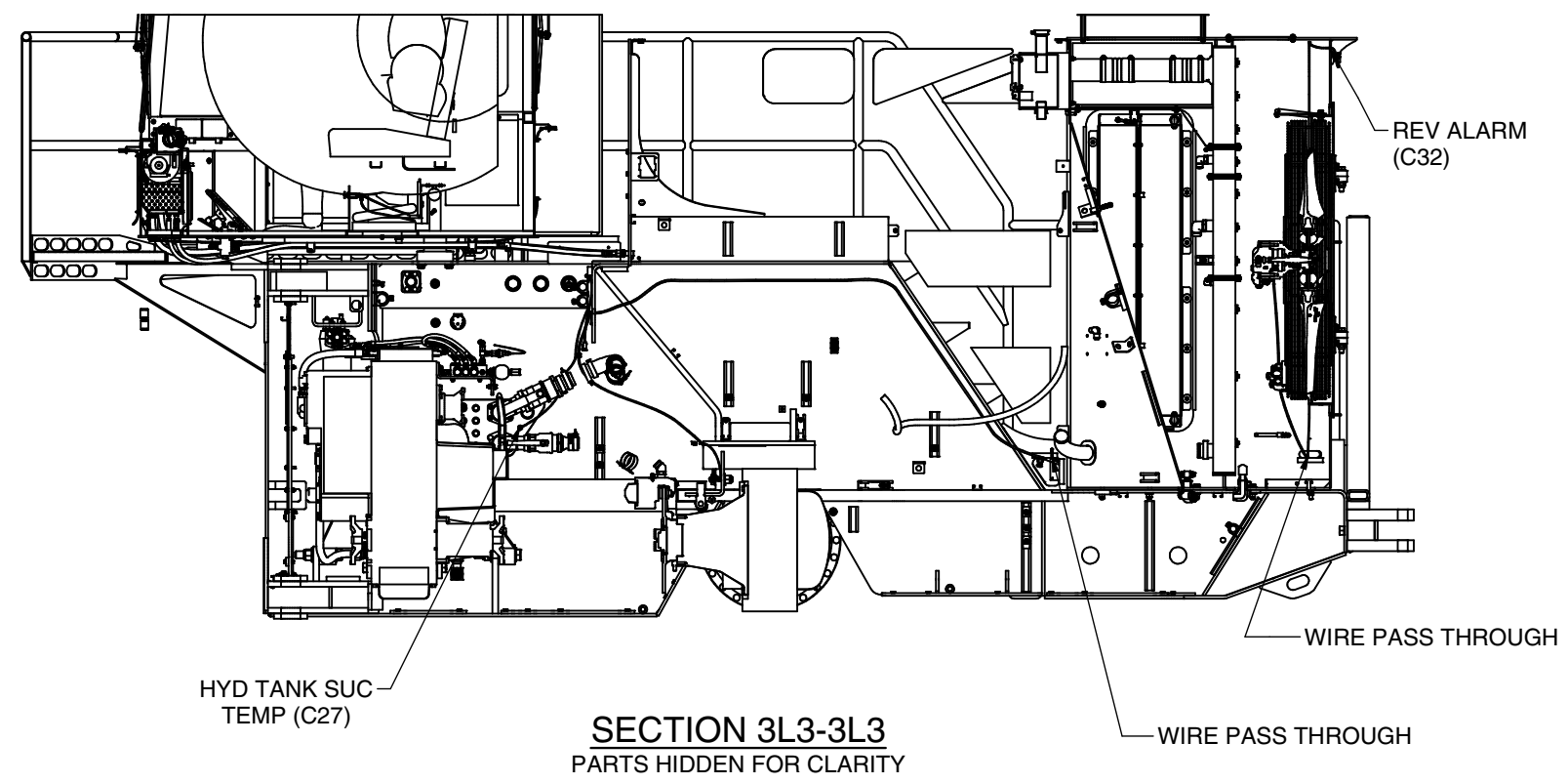
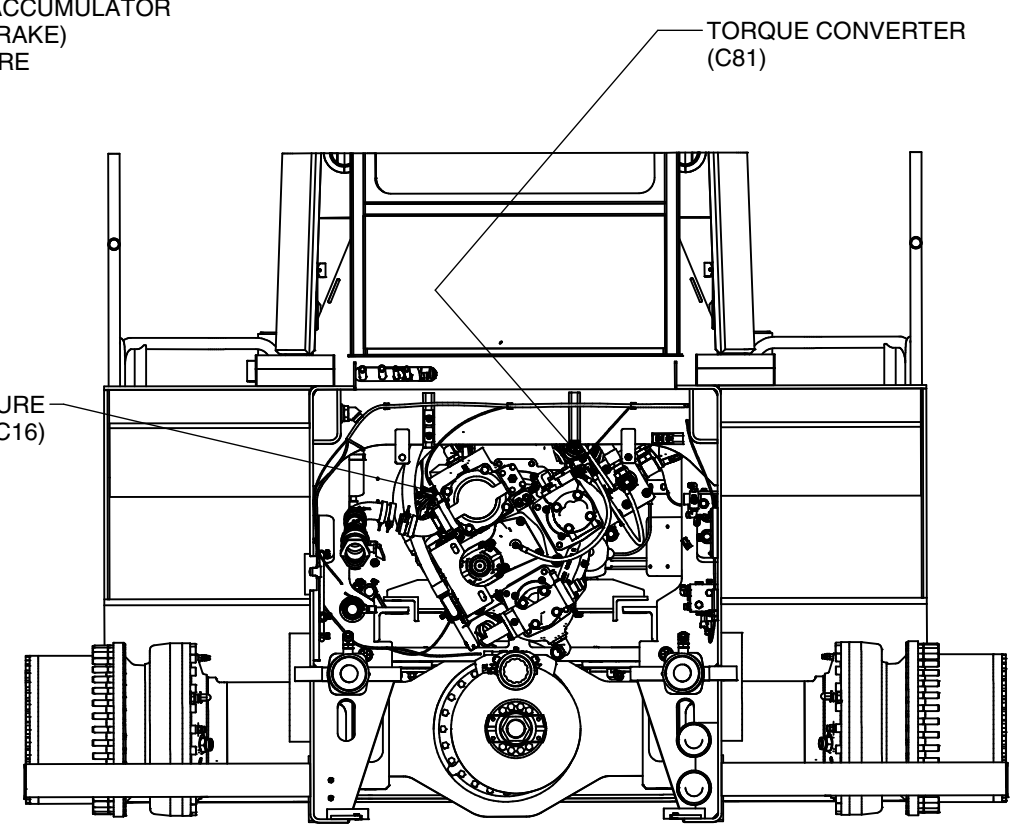
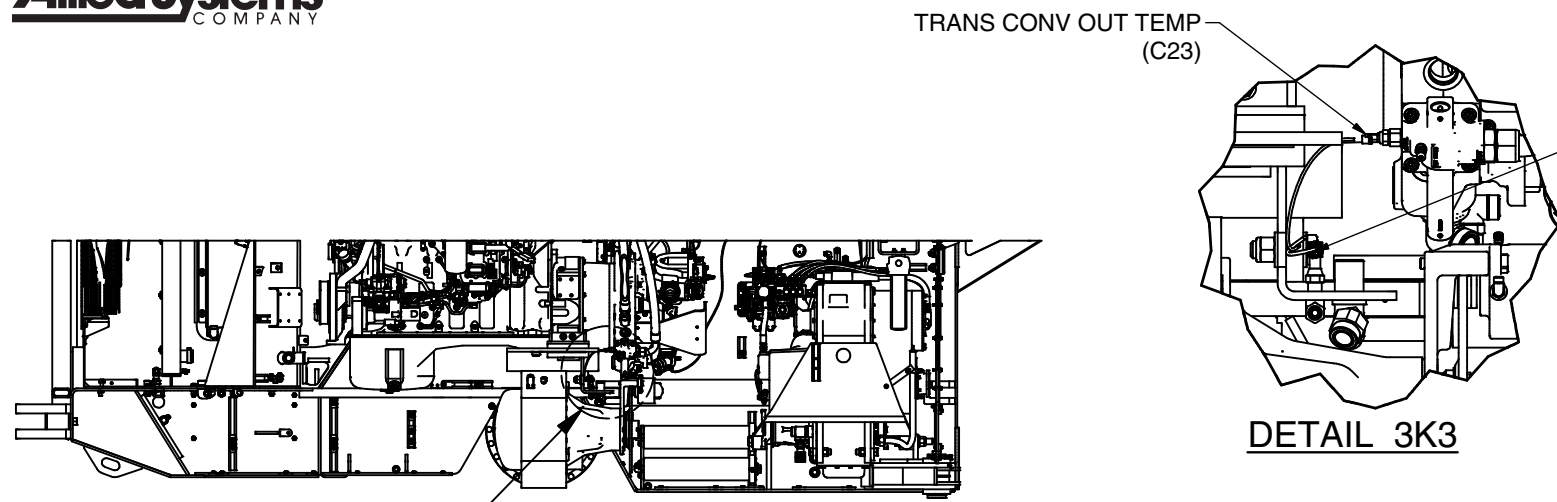

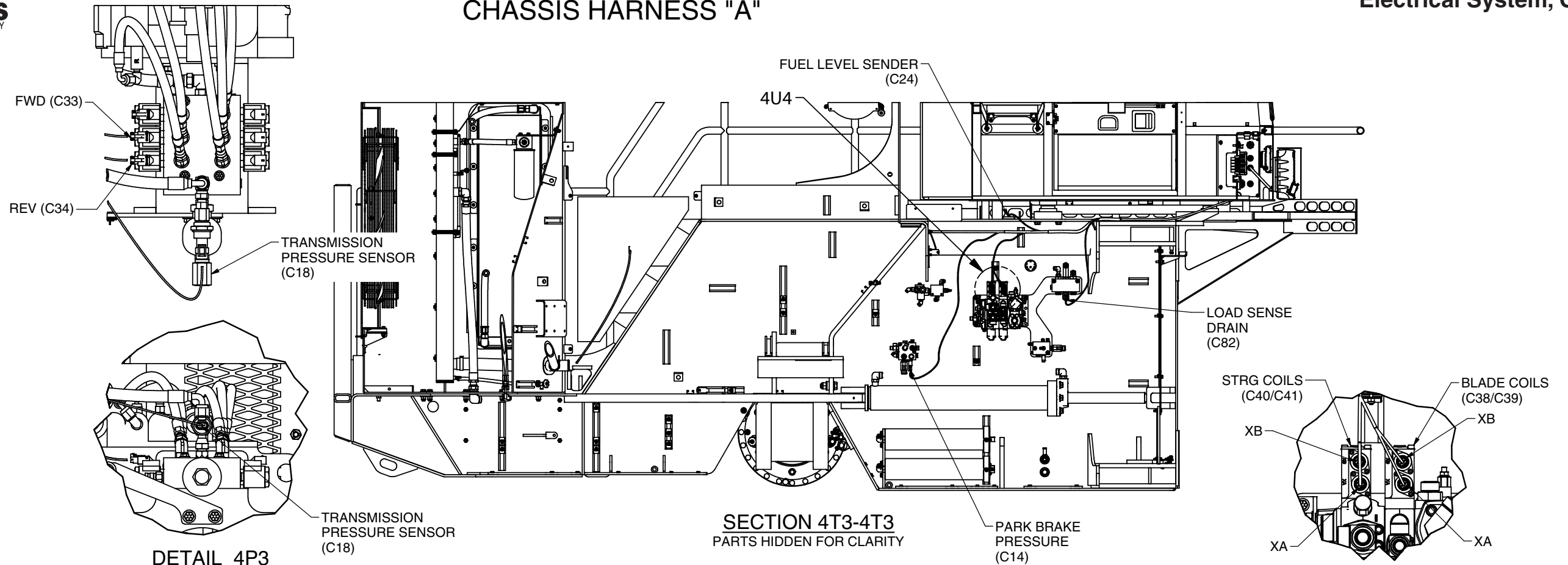

DETAIL 4P3
TRANS SHIFT MANIFOLD

SECTION 4T3-4T3
PARTS HIDDEN FOR CLARITY

DETAIL 4U4

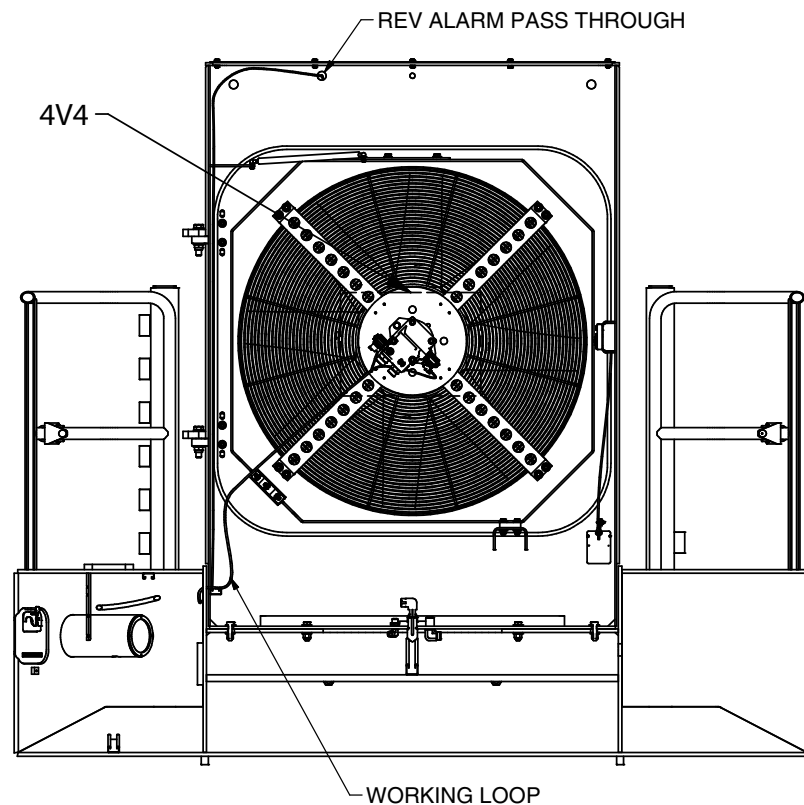

SECTION 4R3-4R3
FAN & REV ALARM CONNECTIONS

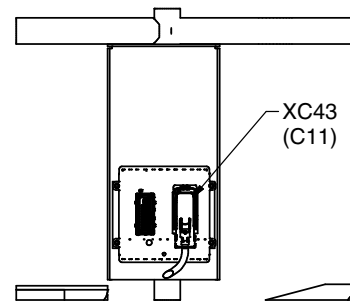

SECTION 4Q3-4Q3
VIEW CROPPED FOR CLARITY

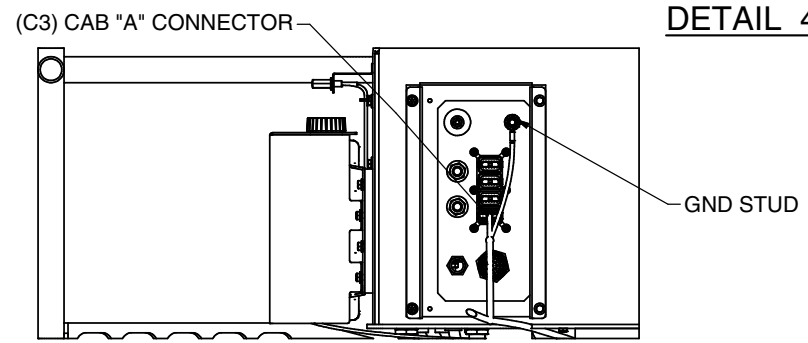

SECTION 4S3-4S3
VIEW CROPPED FOR CLARITY

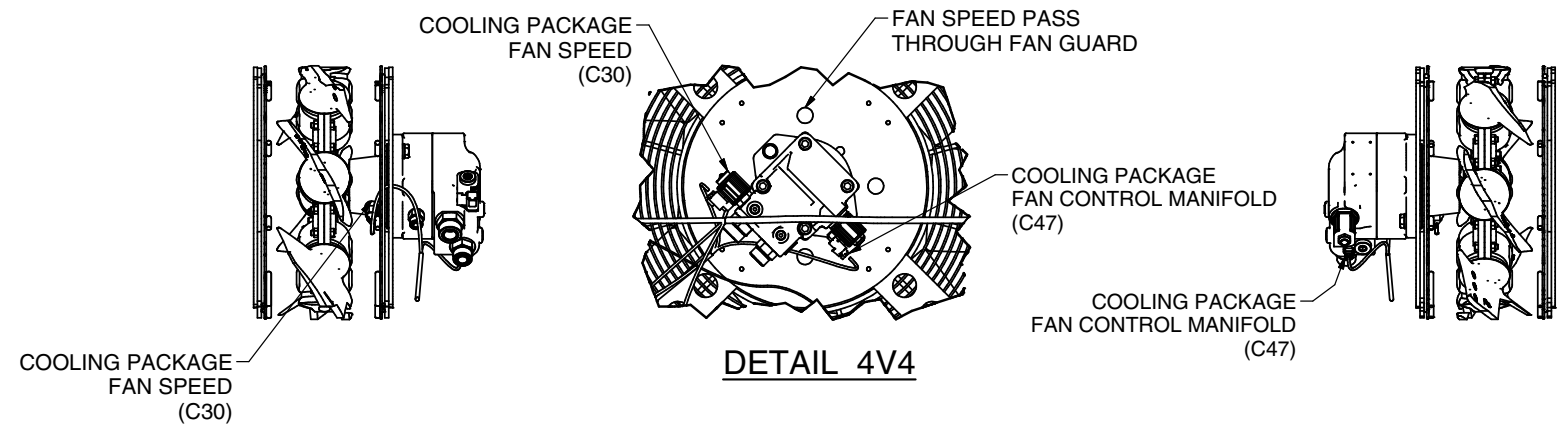

DETAIL 4V4

CHASSIS HARNESS "B"

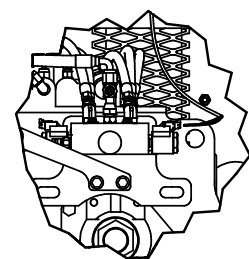
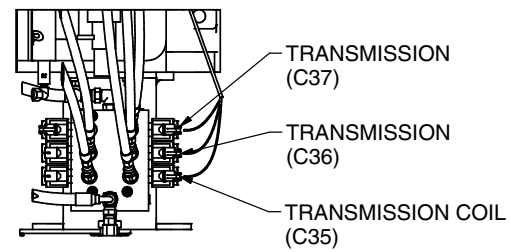
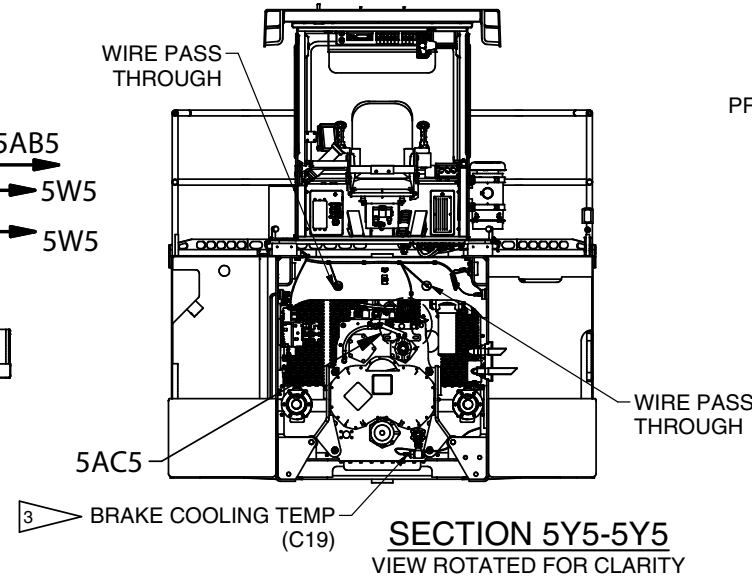
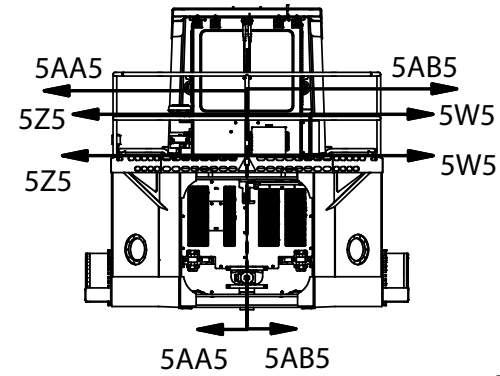
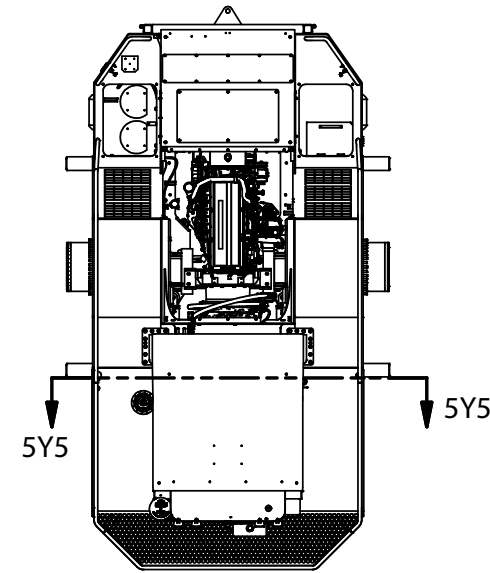

DETAIL 5AC5

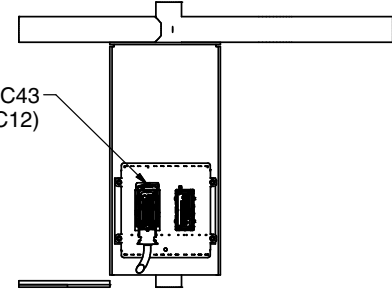

SECTION 5W5-5W5
VIEW CROPPED FOR CLARITY

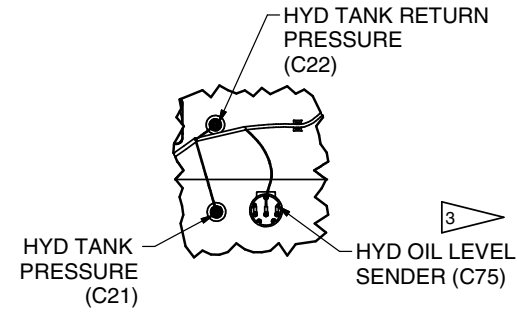

DETAIL 5X5

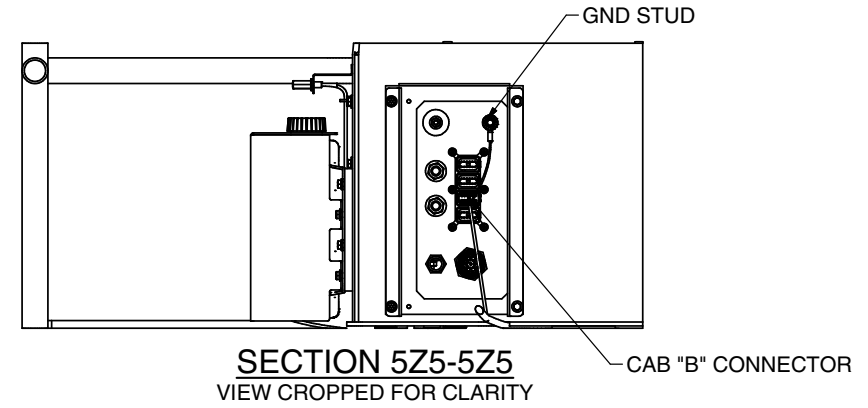

SECTION 5Z5-5Z5
VIEW CROPPED FOR CLARITY

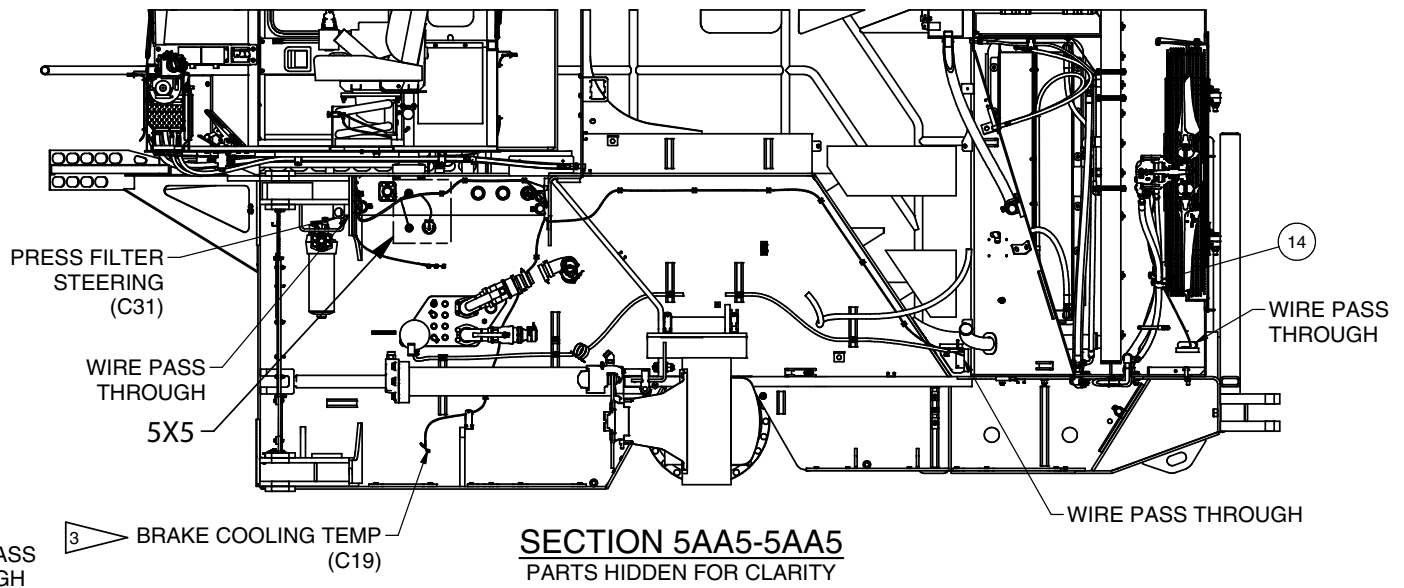

SECTION 5AA5-5AA5
PARTS HIDDEN FOR CLARITY

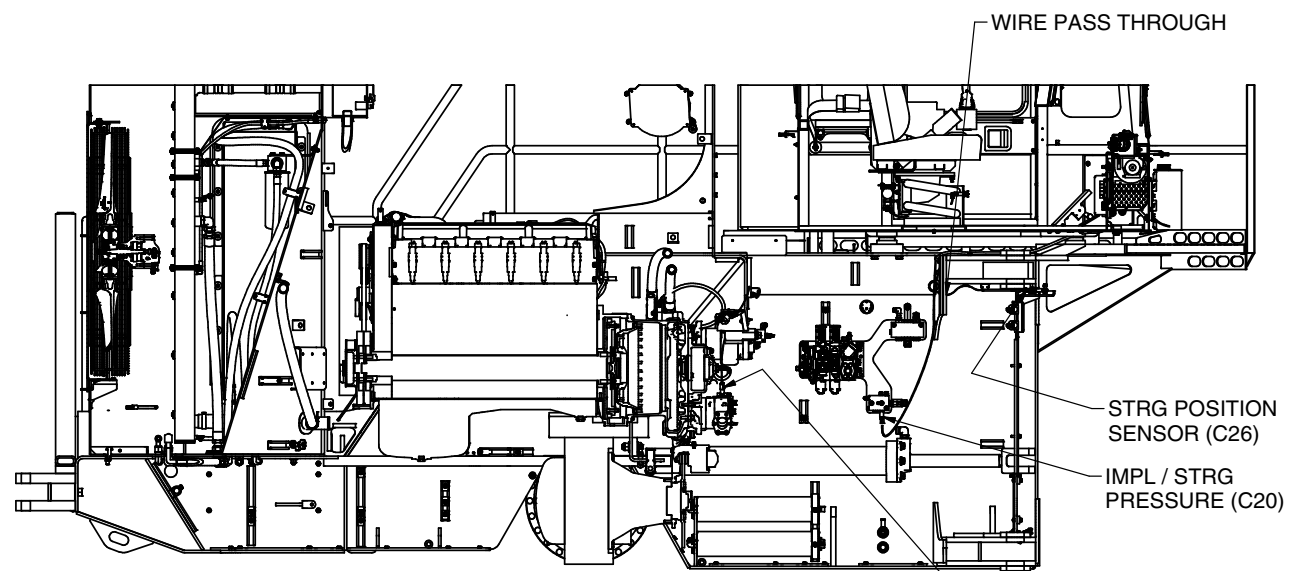

SECTION 5AB5-5AB5
PARTS HIDDEN FOR CLARITY

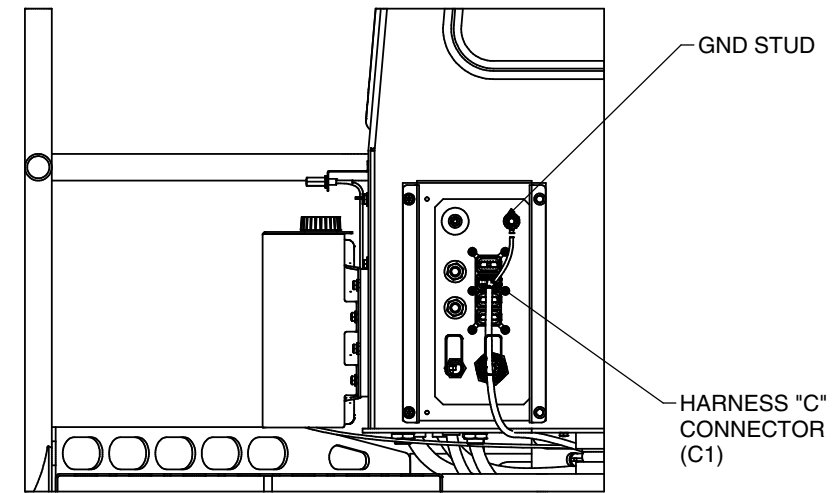
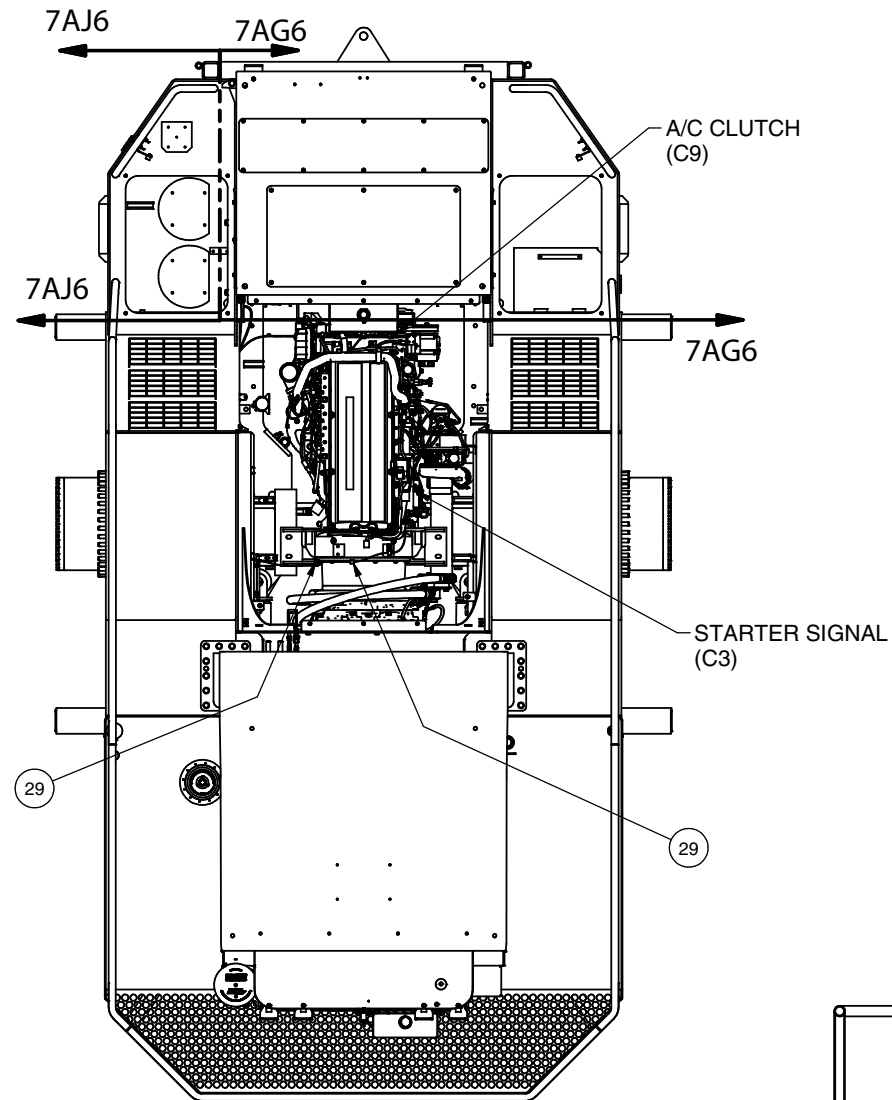

SECTION 6AF6-6AF6
VIEW CROPPED FOR CLARITY

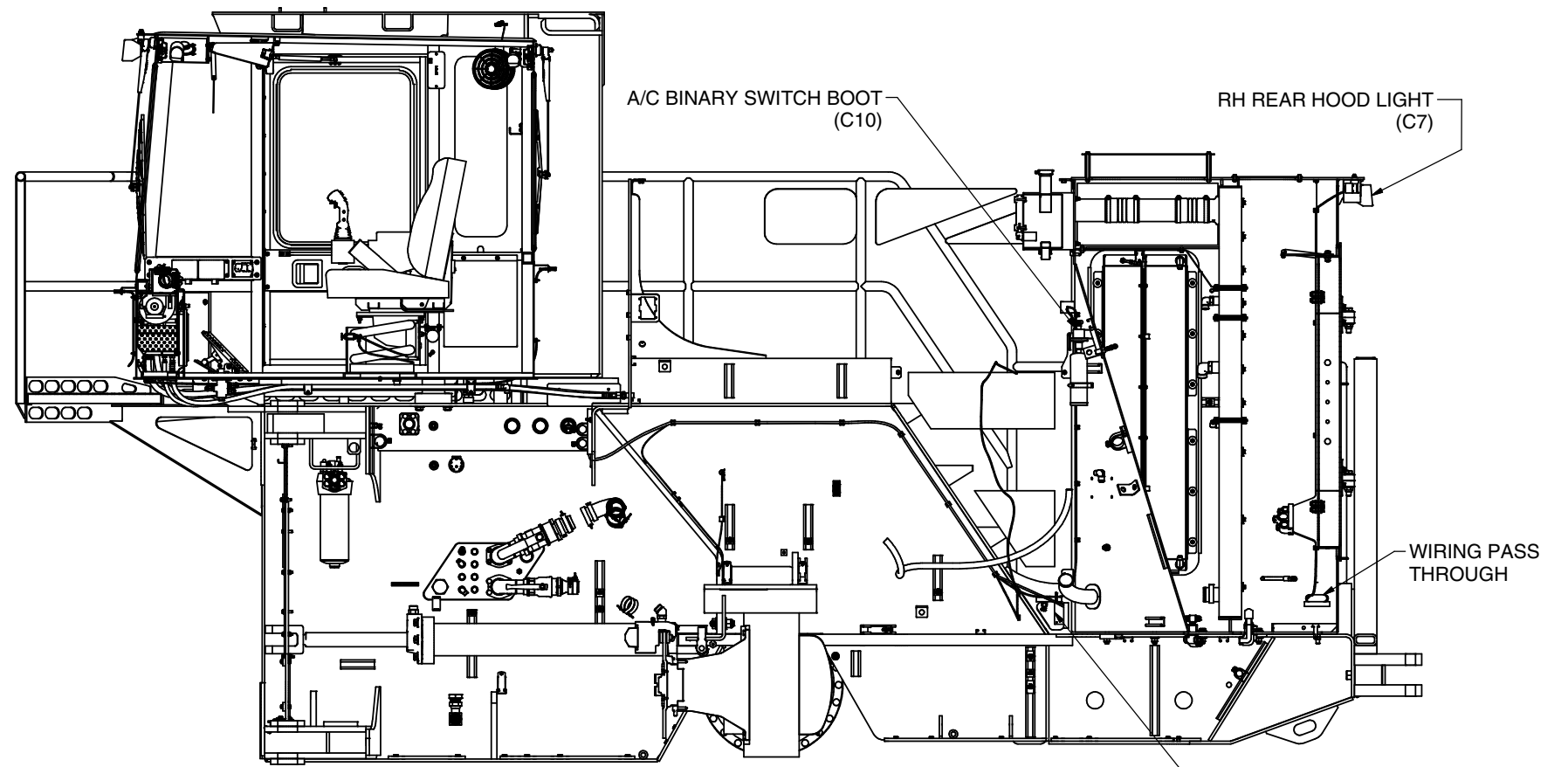
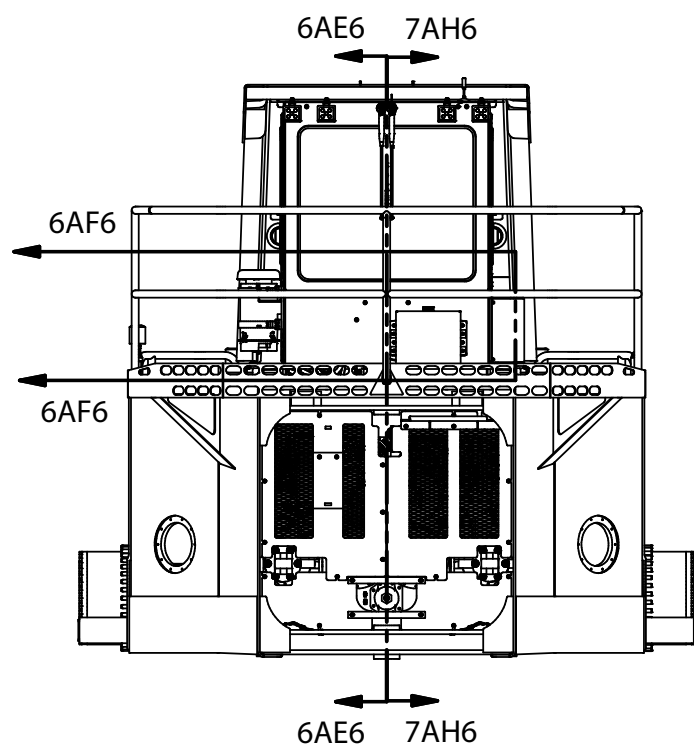

SECTION 6AE6-6AE6
PARTS HIDDEN FOR CLARITY

CHASSIS HARNESS "C"

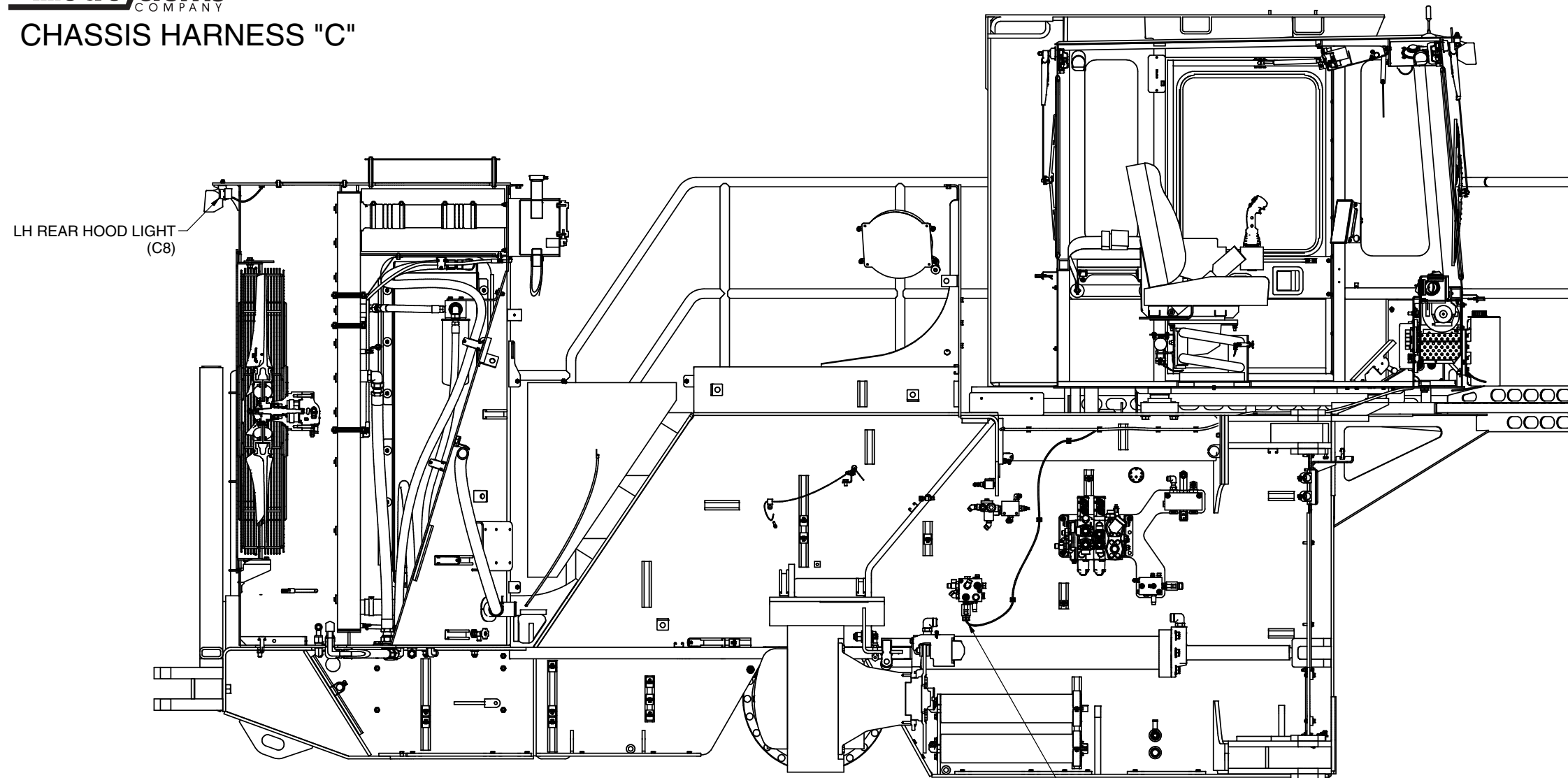

SECTION 7AH6-7AH6
PARTS HIDDEN FOR CLARITY

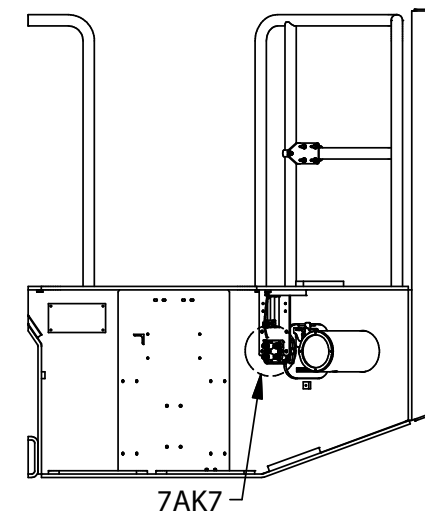

SECTION 7AJ6-7AJ6
VIEW ROTATED FOR CLARITY

BATTERY DISCONNECT
UN-SWITCHED POWER
TERMINAL 3

IQAN RELAY GND
MASTER SWITCH
TERMINAL 6

DETAIL 7AK7

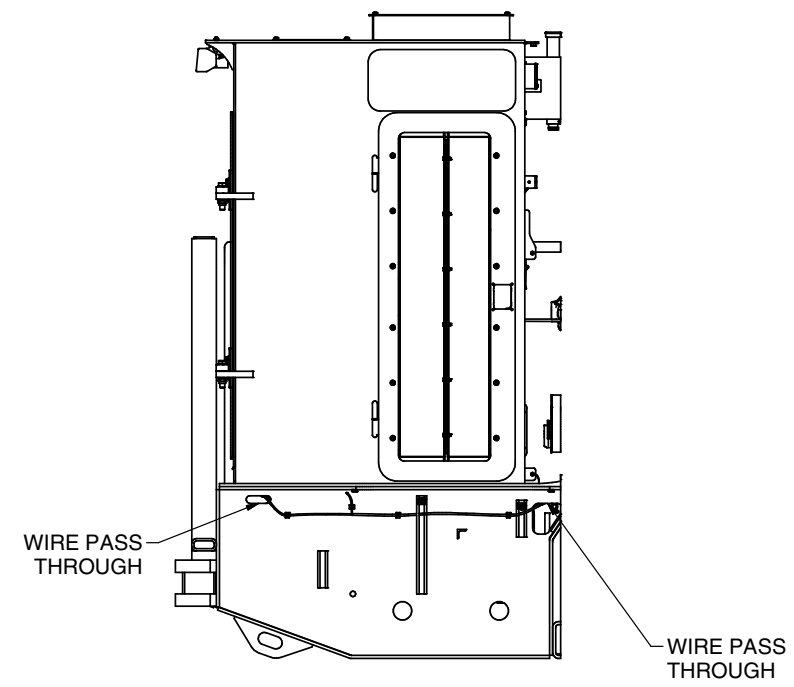

SECTION 7AG6-7AG6
VIEW ROTATED FOR CLARITY

CHASSIS HARNESS "D"

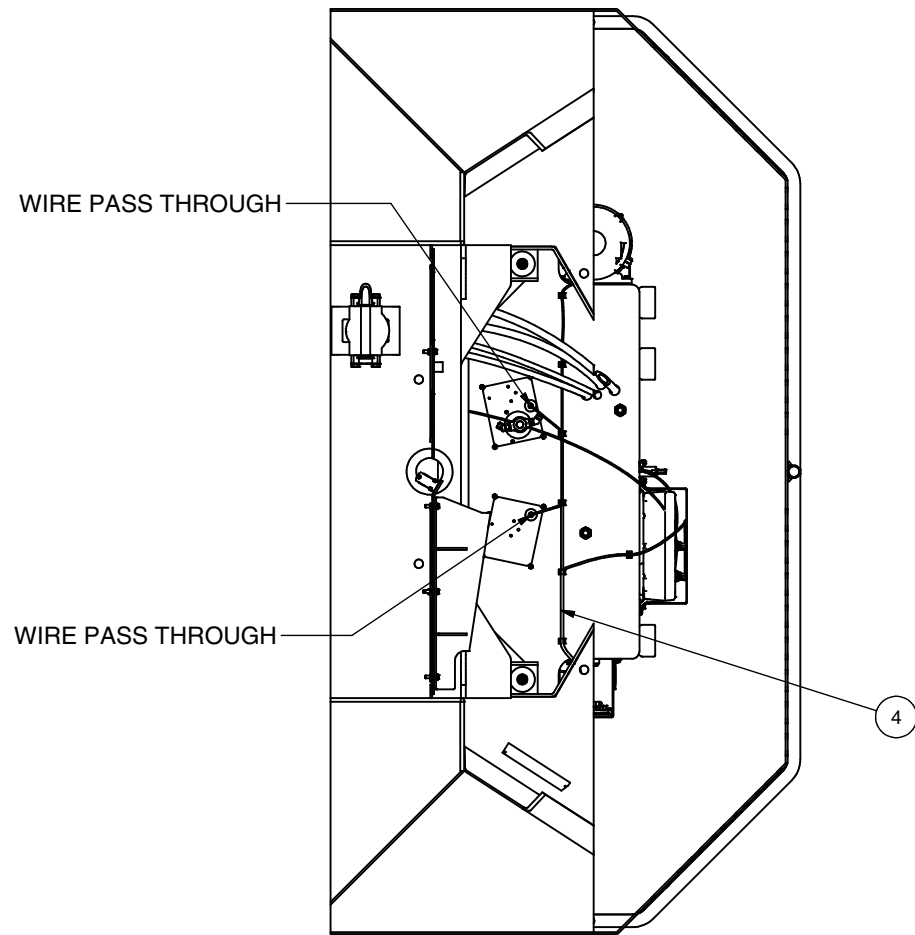
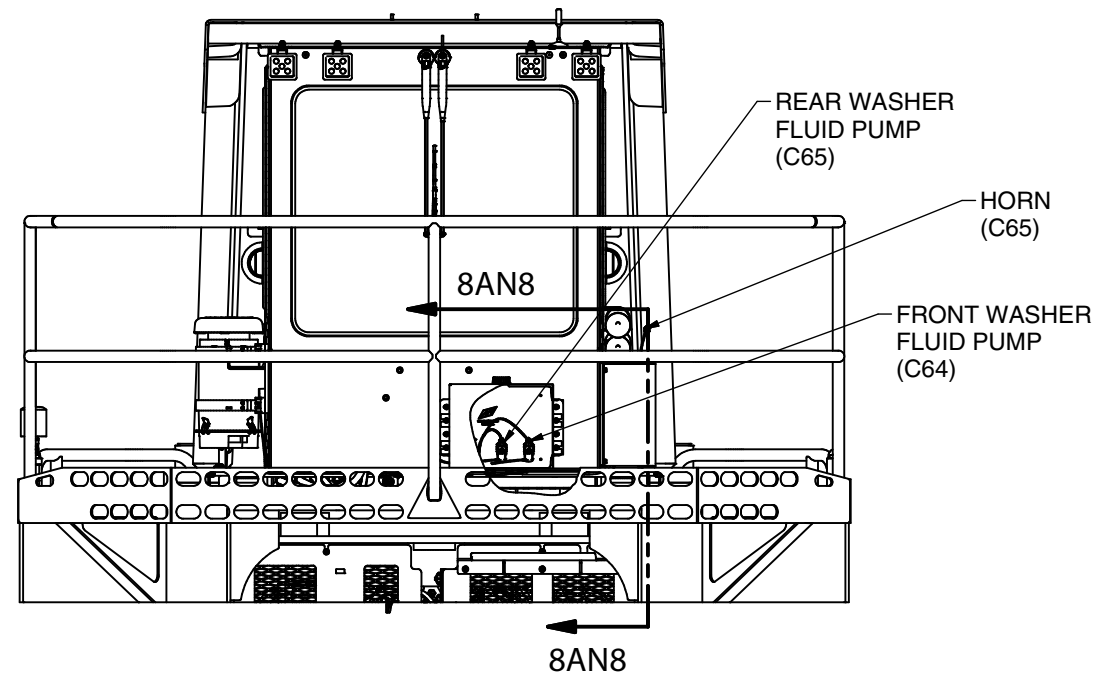
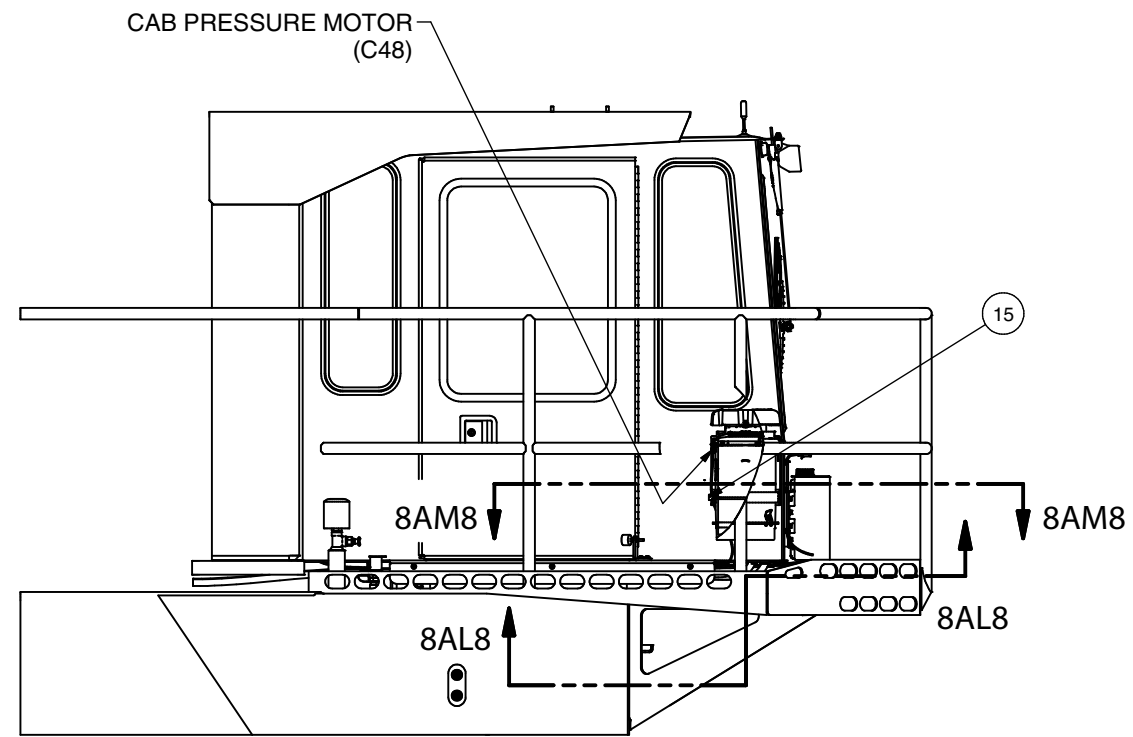

SECTION 8AL8-8AL8

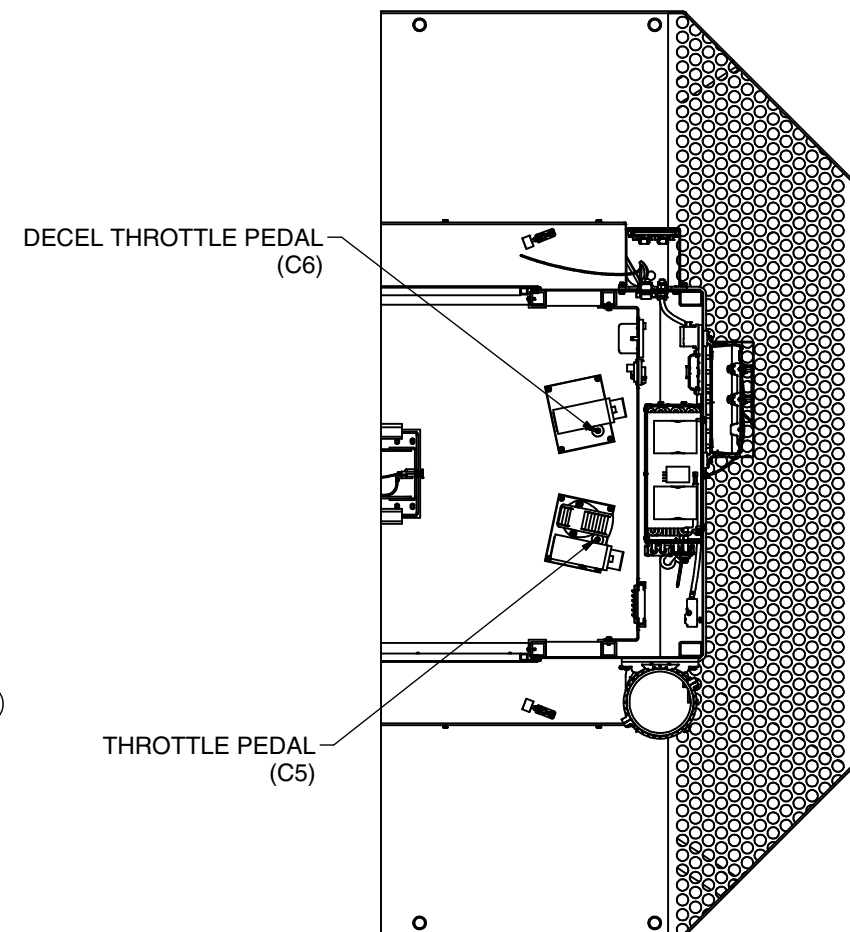

SECTION 8AM8-8AM8

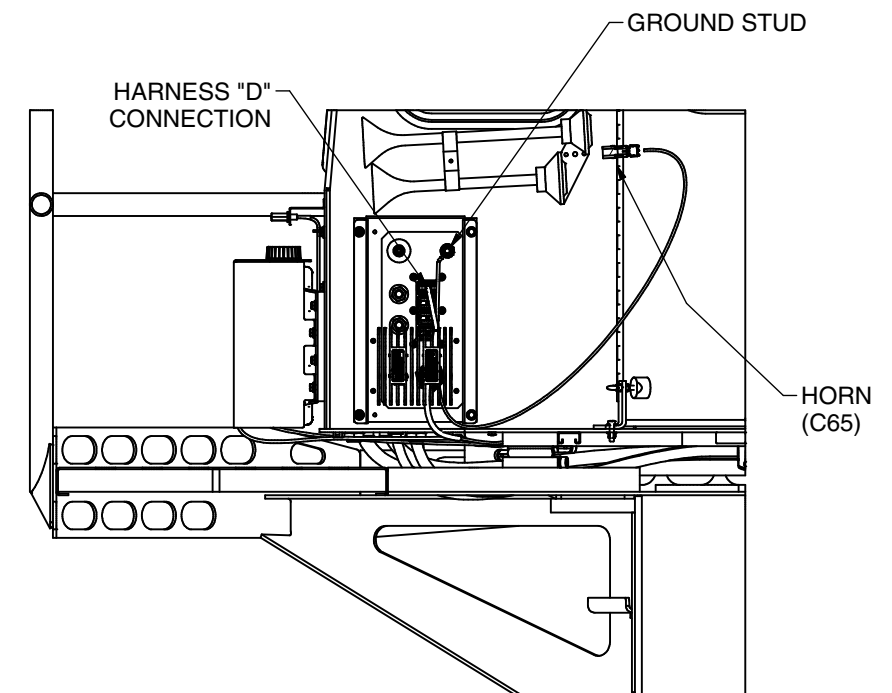

SECTION 8AN8-8AN8
VIEW CROPPED FOR CLARITY

HARNESS, AFTER TREATMENT; QSX15 T4F

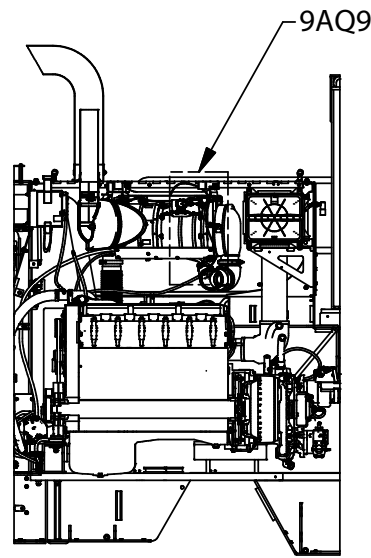

SECTION 9AT9-9AT9

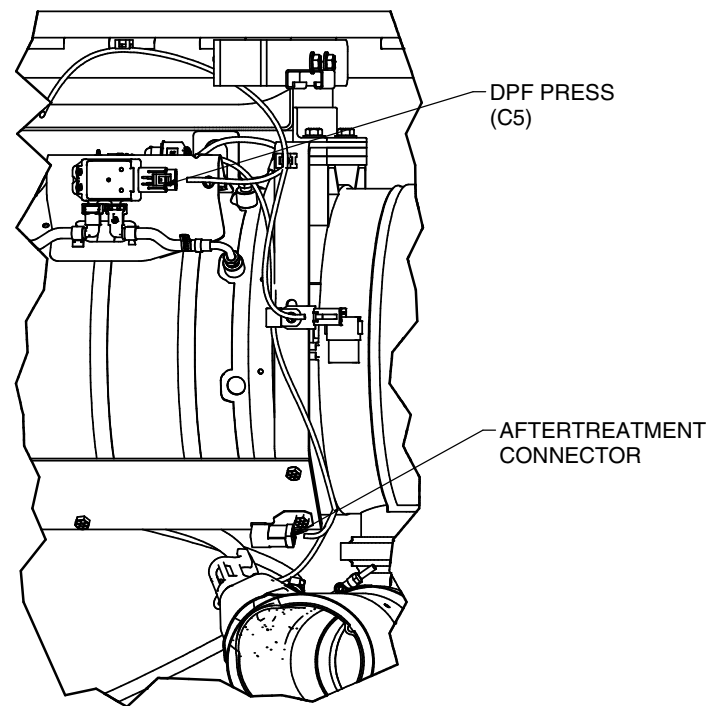

DETAIL 9AQ9

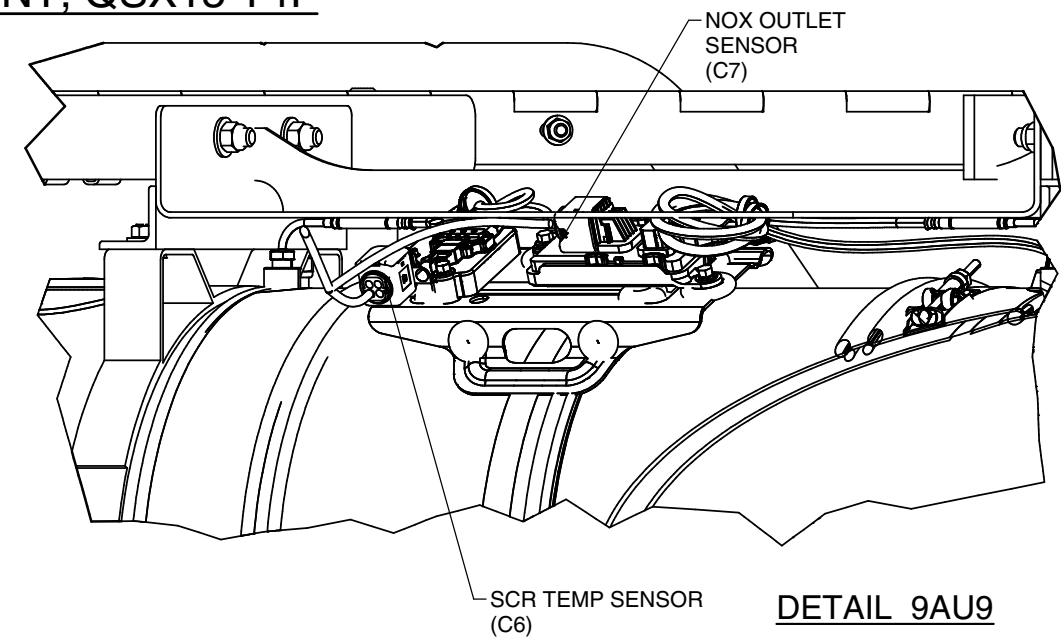

DETAIL 9AU9

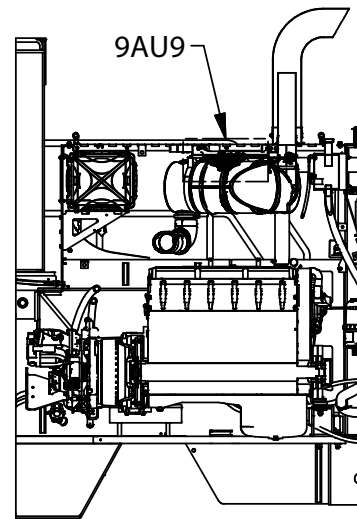

SECTION 9AS9-9AS9
VIEW ROTATED FOR CLARITY

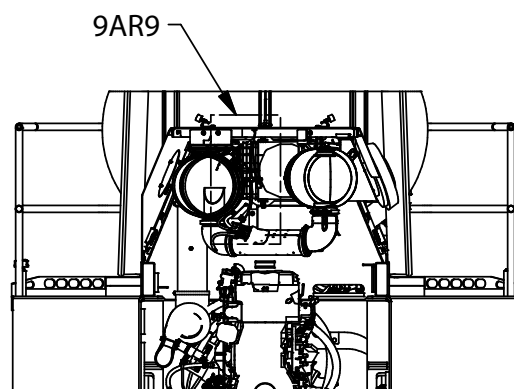
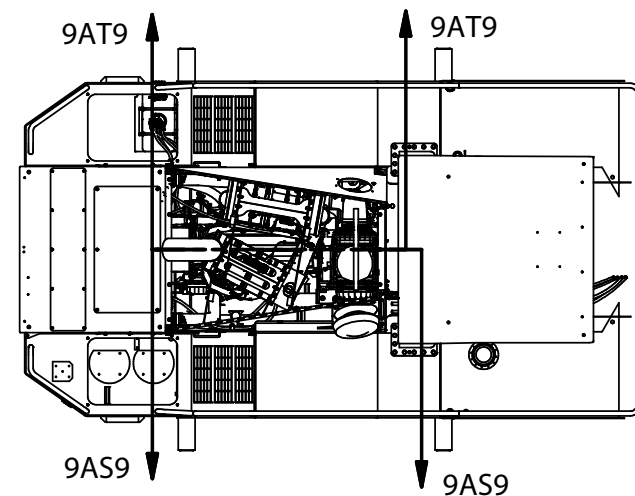

SECTION 9AP9-9AP9

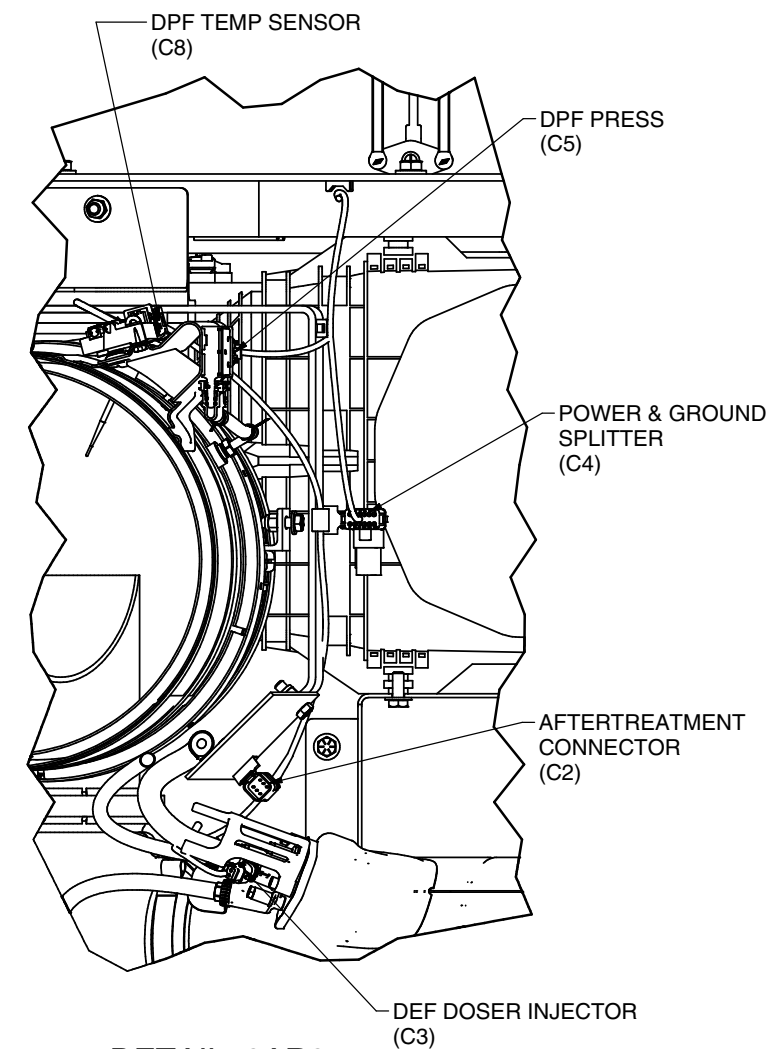
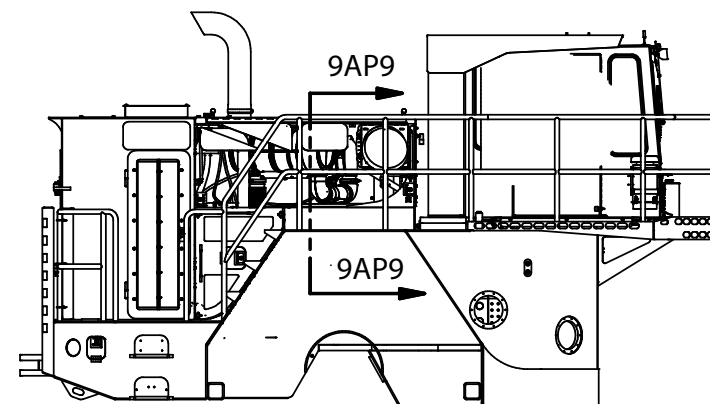

DETAIL 9AR9

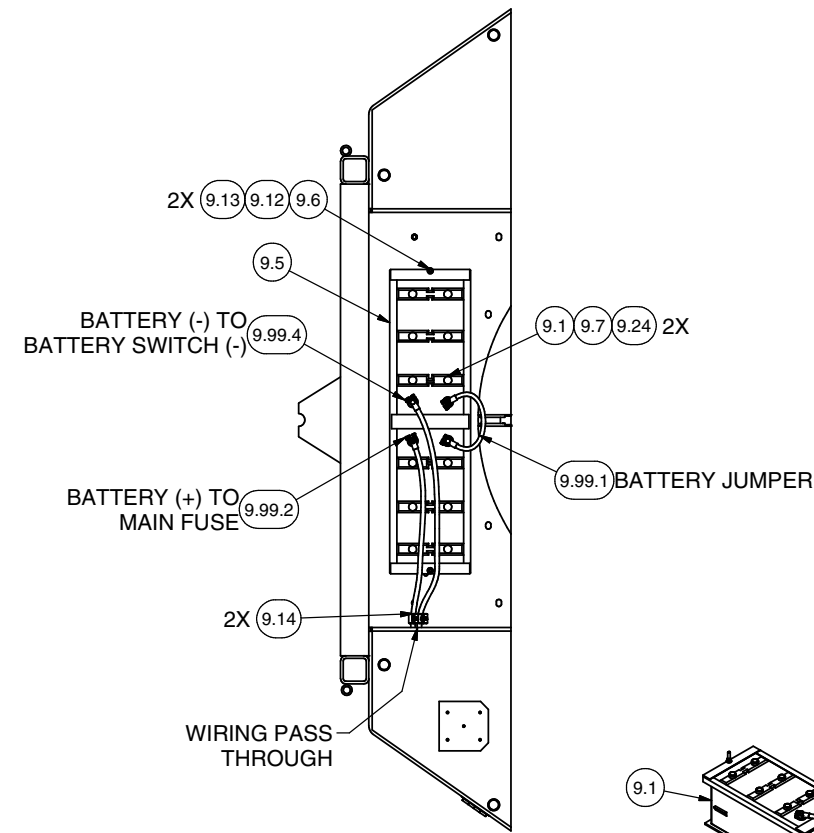

**SECTION 10AW10-10AW10
BATTERIES INSIDE OF AIR BOX**

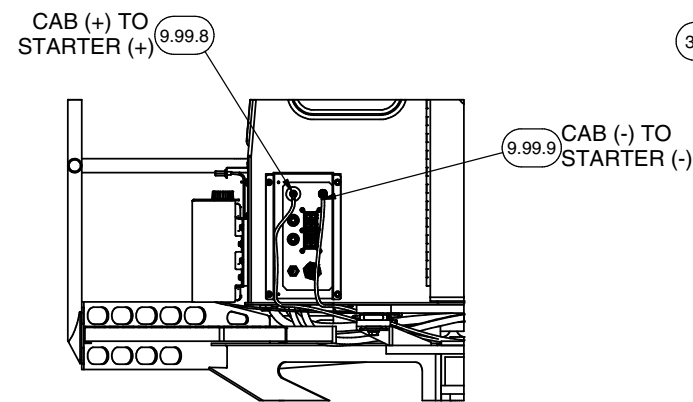
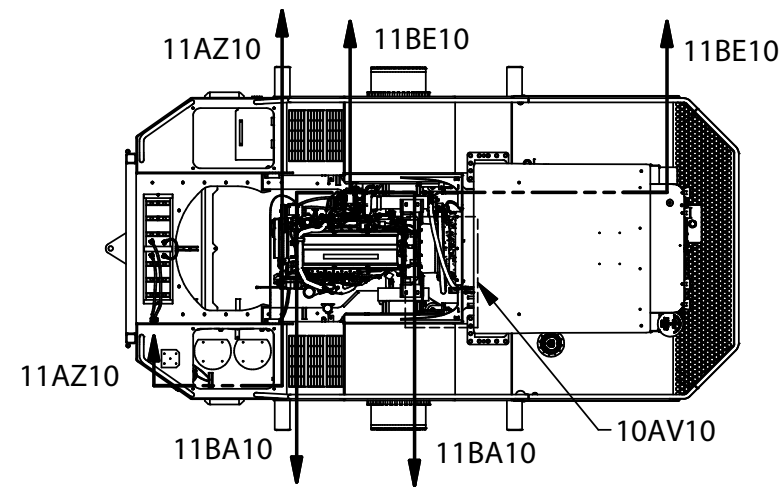
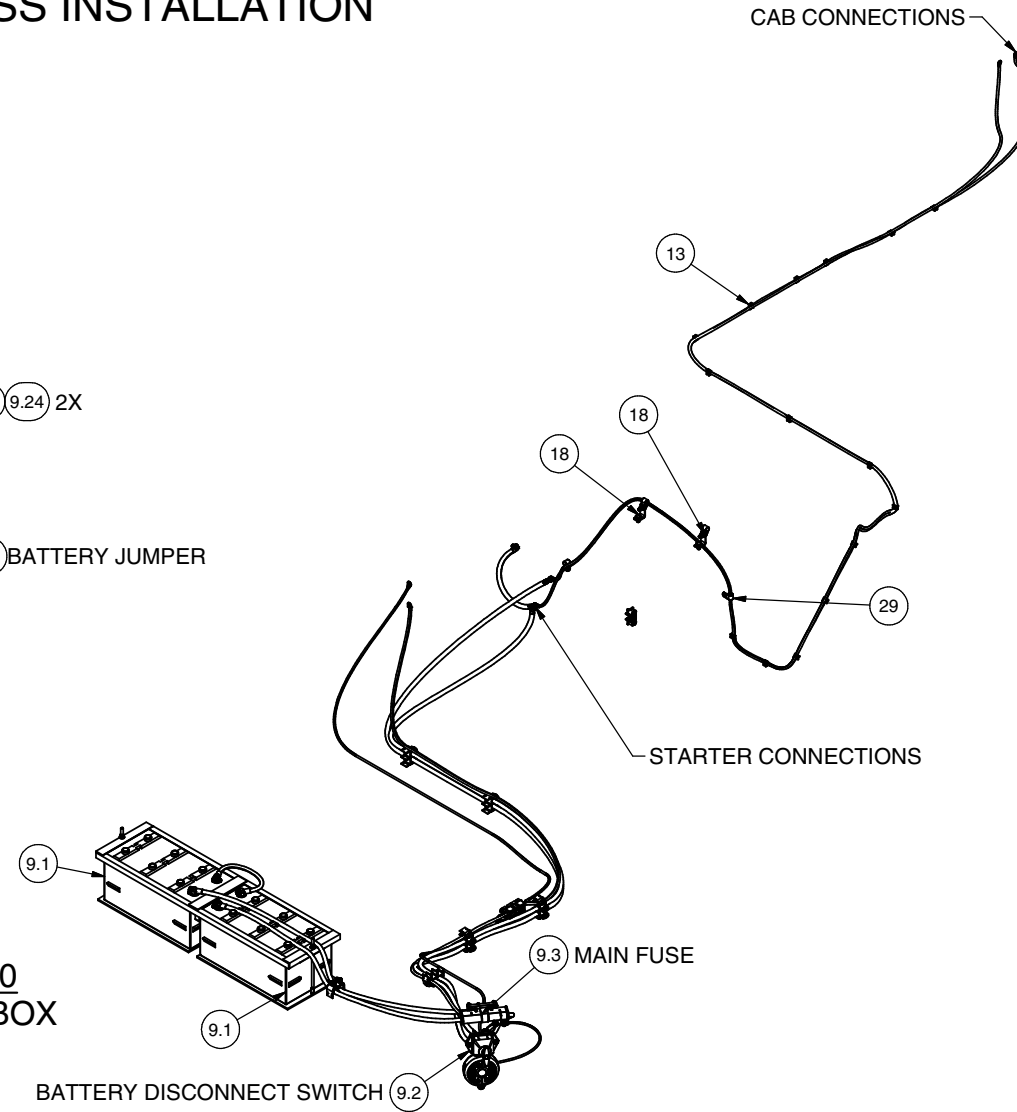

**SECTION 10AX10-10AX10
CAB CONNECTIONS
VIEW CROPPED FOR CLARITY**

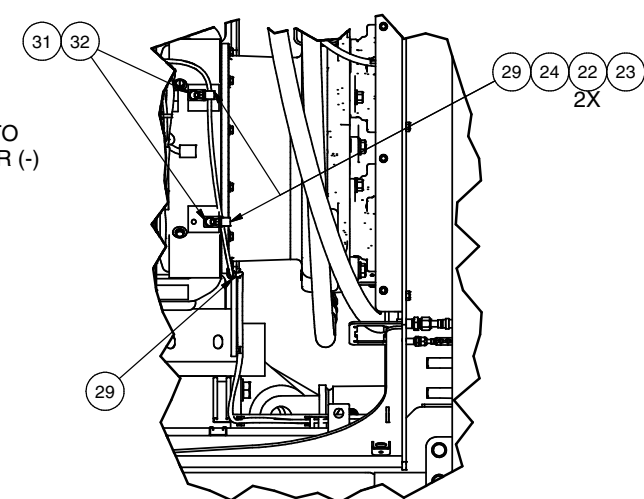

DETAIL 10AV10

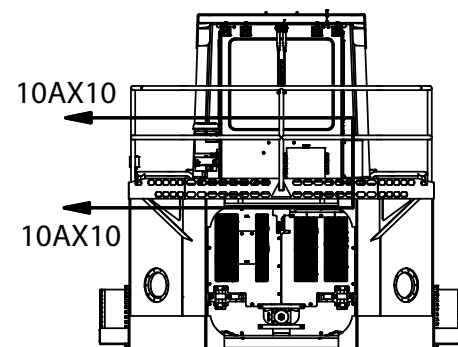
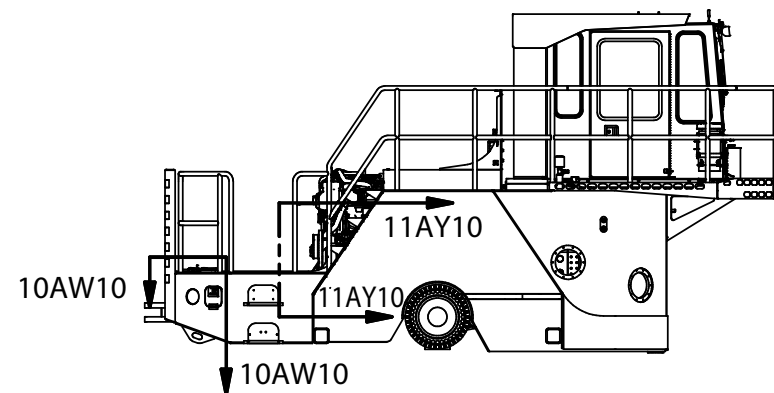

CUMMINS BATTERY HARNESS INSTALLATION

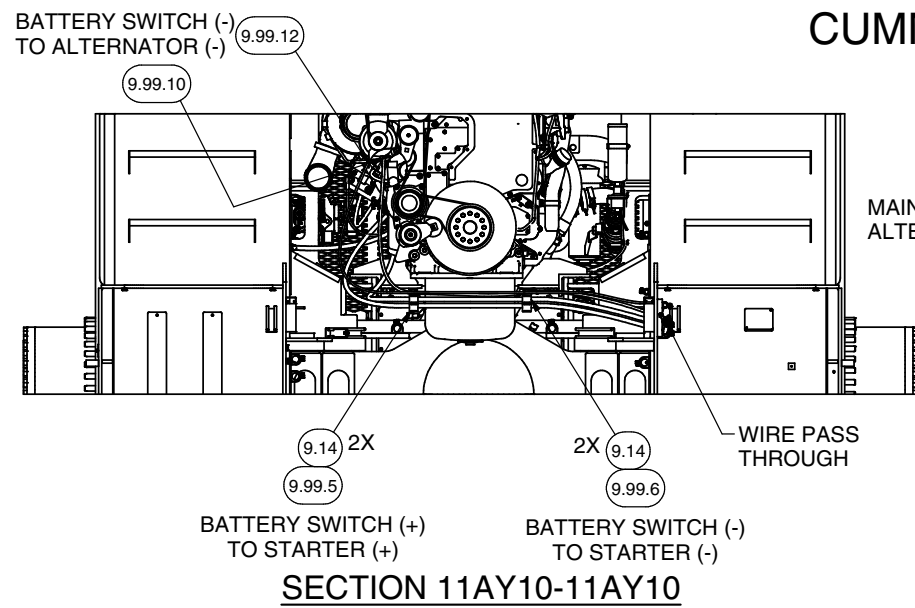

SECTION 11AY10-11AY10

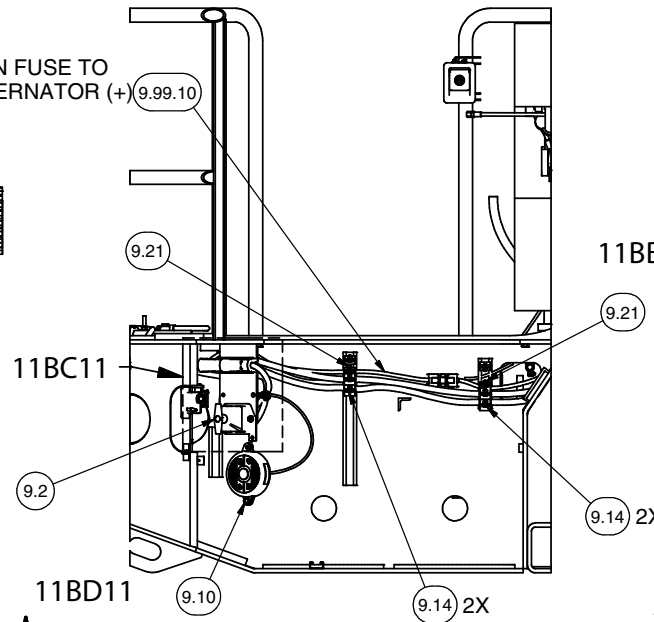

SECTION 11AZ10-11AZ10

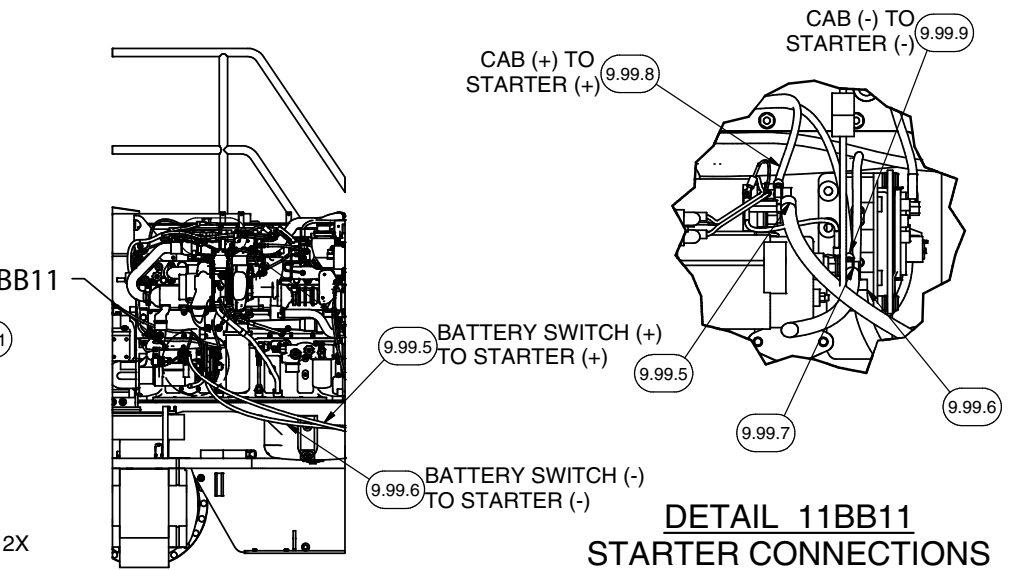

SECTION 11BA10-11BA10

**DETAIL 11BB11
STARTER CONNECTIONS**

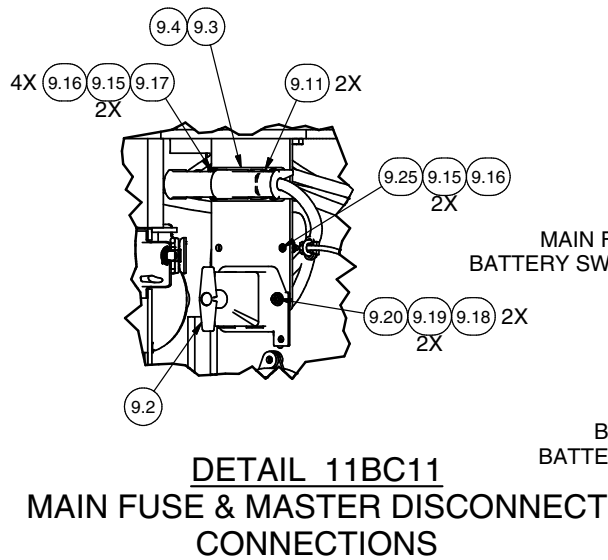

**DETAIL 11BC11
MAIN FUSE & MASTER DISCONNECT
CONNECTIONS**

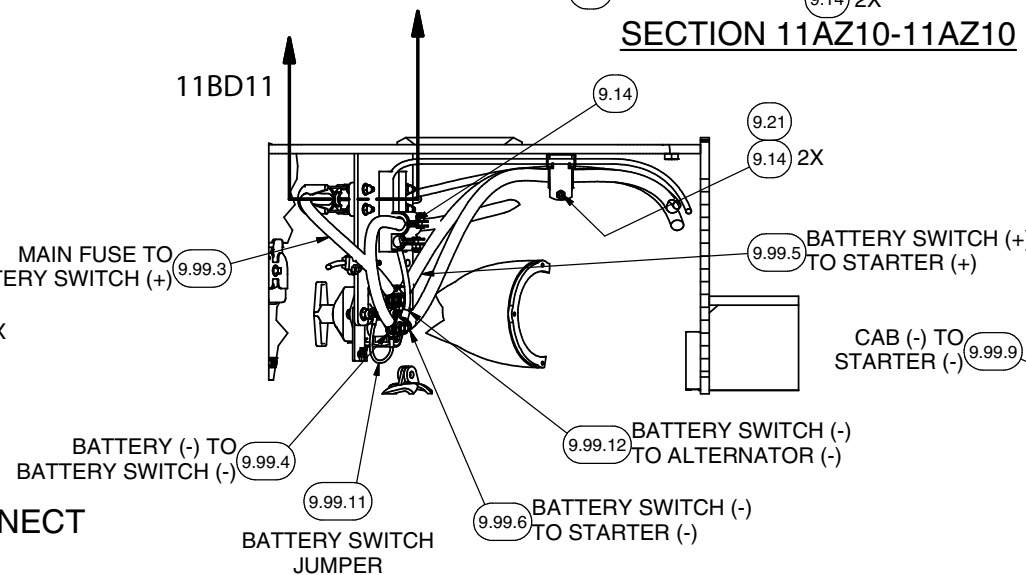

**SECTION 11BD11-11BD11
MAIN FUSE CONNECTIONS**

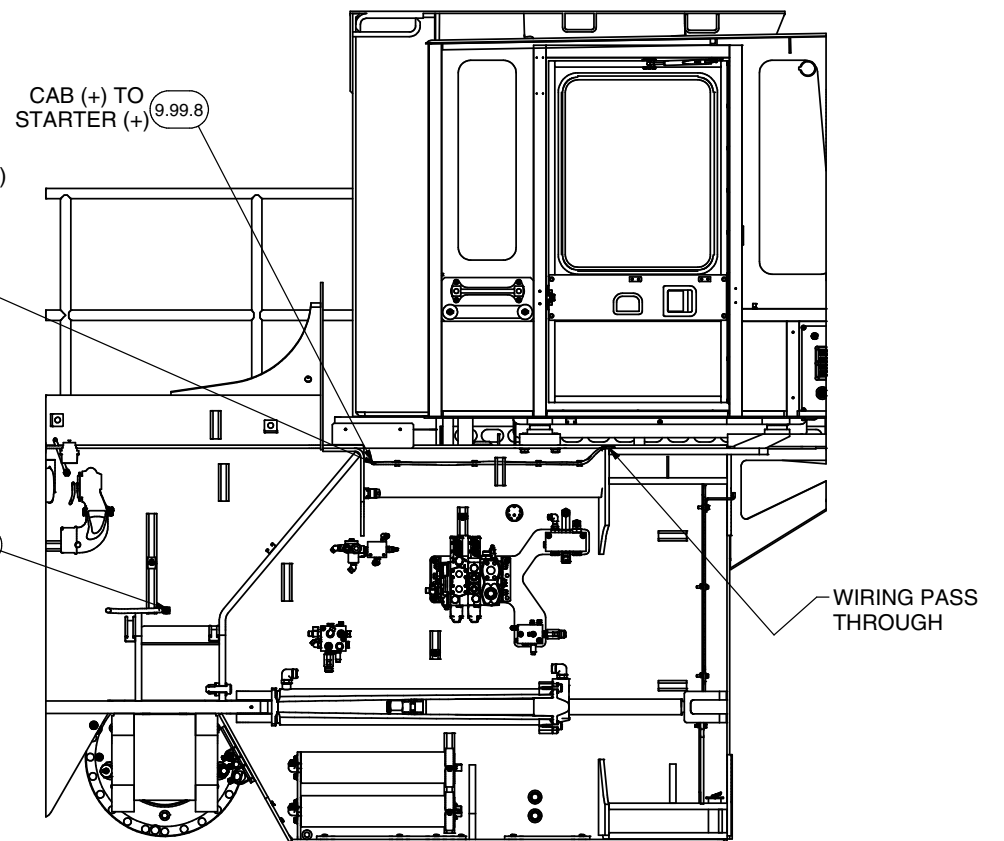

**SECTION 11BE10-11BE10
PARTS HIDDEN FOR CLARITY**

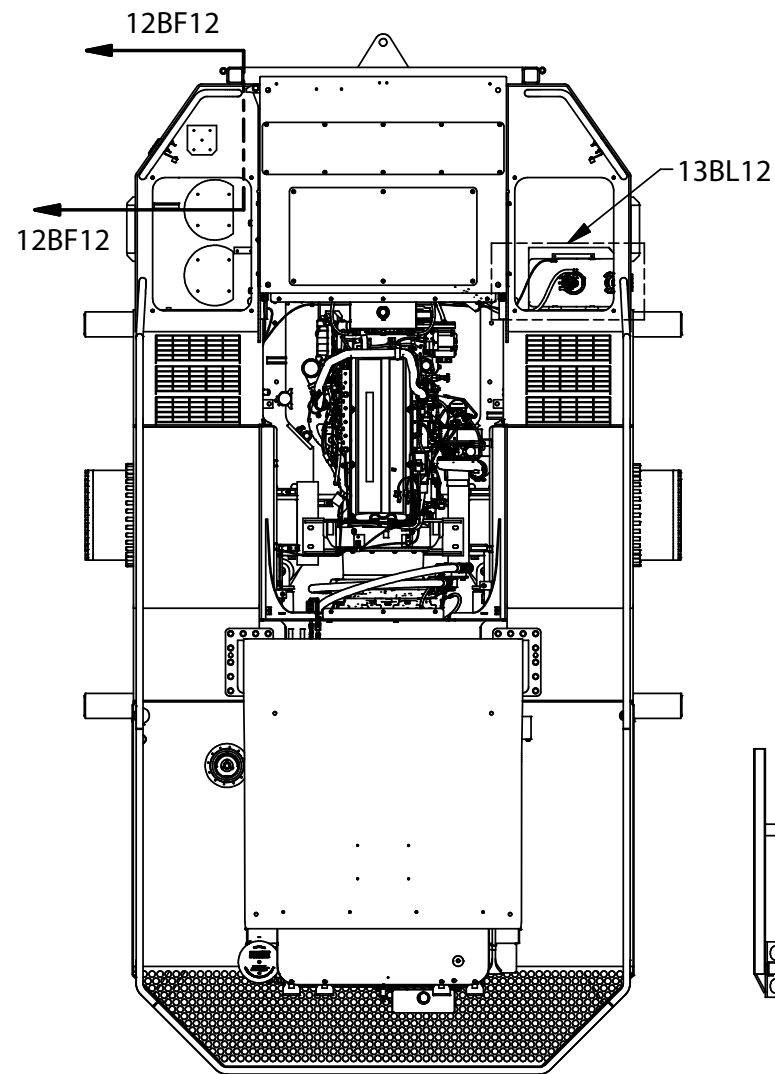

SECTION 12BF12-12BF12
VIEW ROTATED FOR CLARITY

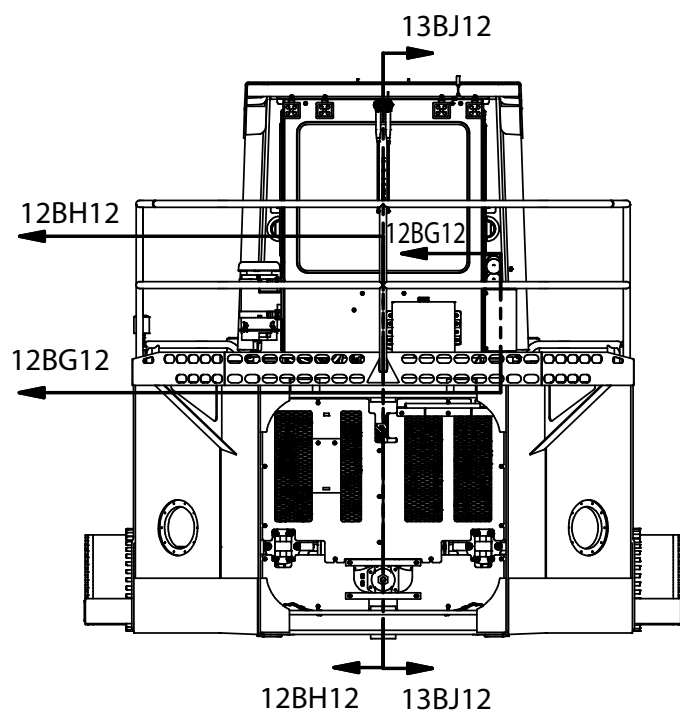
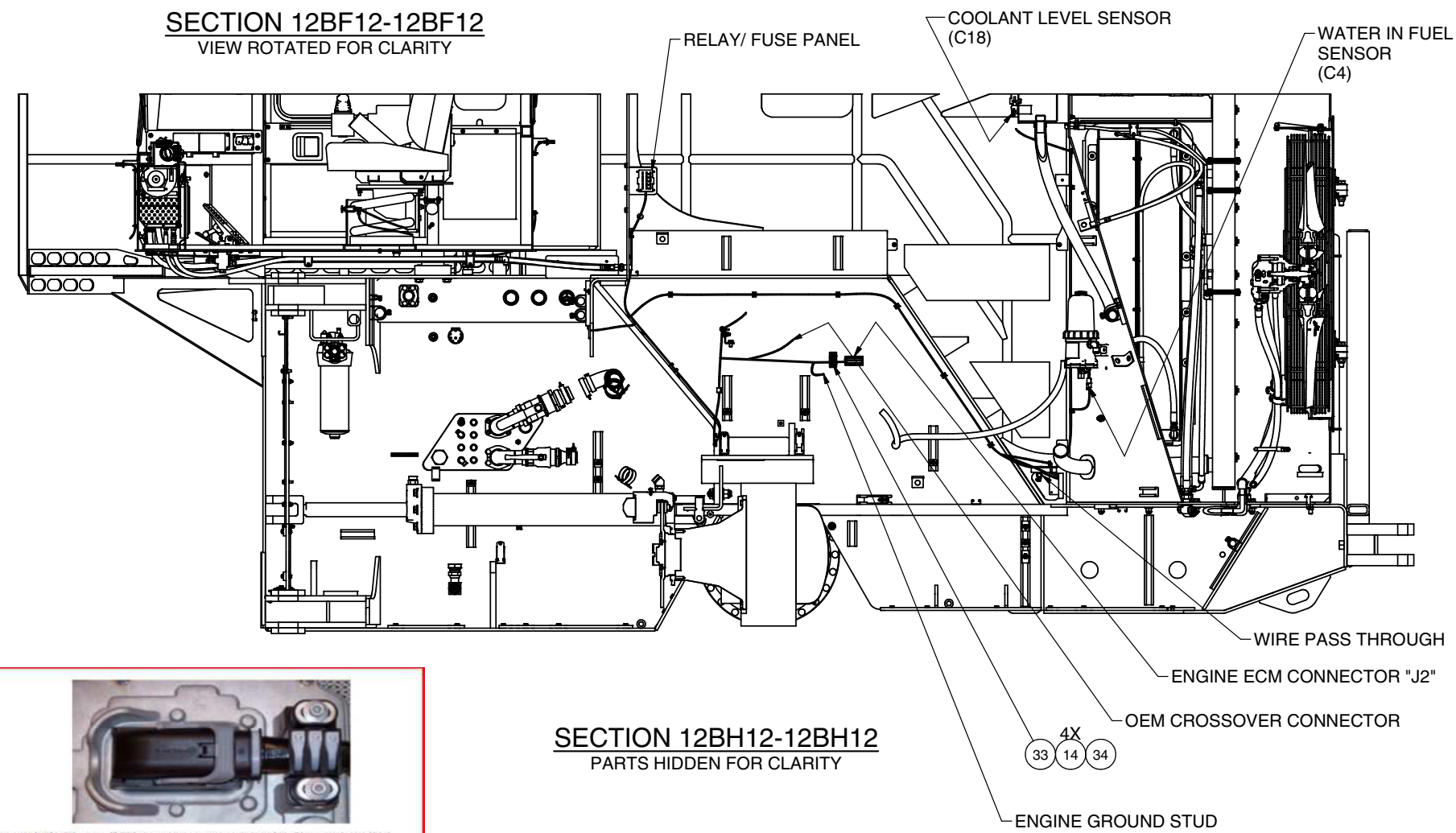
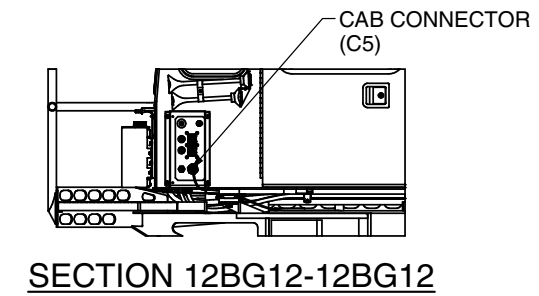
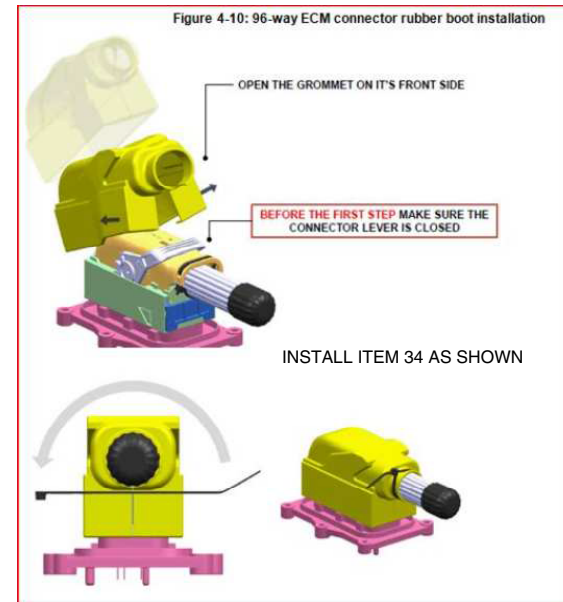

OEM CONNECTOR INSTALLED WITH CLAMP
USE 3X CABLE TIES TO SECURE HARNESS
TORQUE CLAMP SCREWS TO 6 IN-LBS

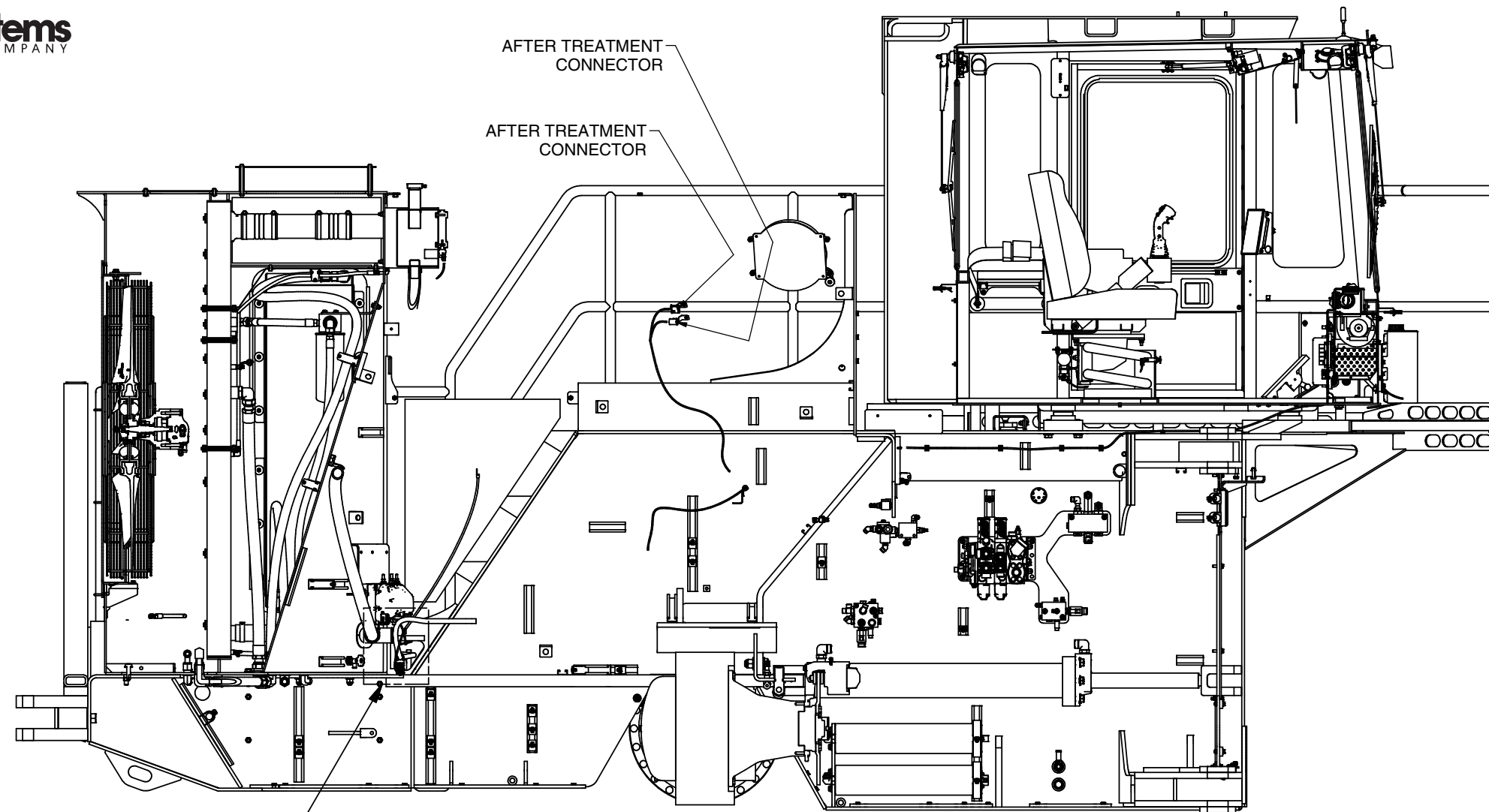

SECTION 13BJ12-13BJ12
PARTS HIDDEN FOR CLARITY

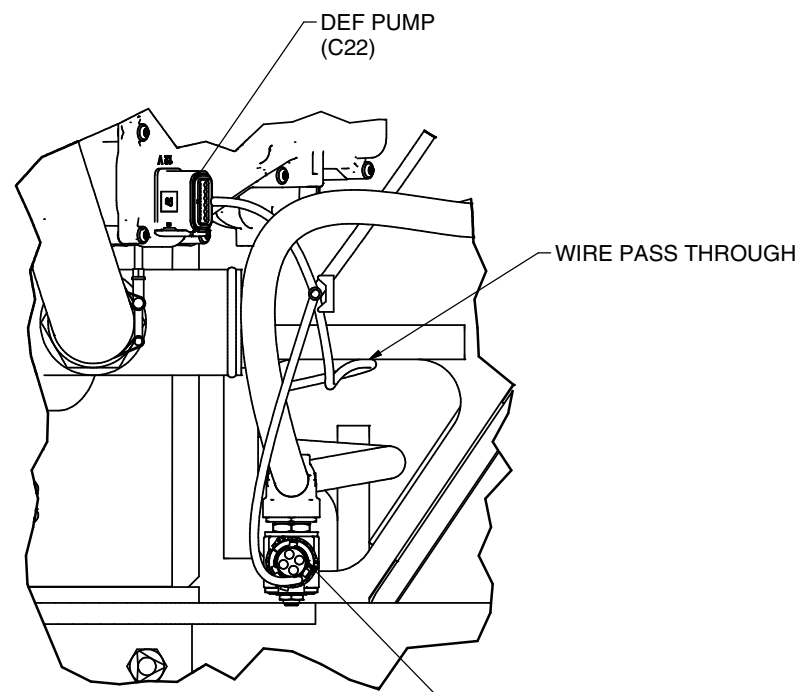

DETAIL 13BK13

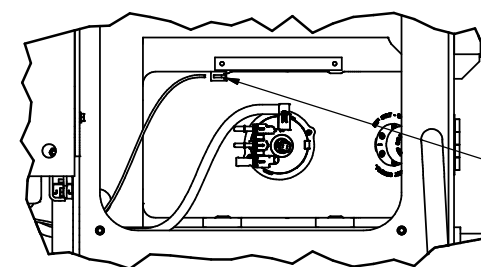

DETAIL 13BL12

- DEF LINE HEATER 1 (C19)
- DEF LINE HEATER 2 (C20)
- DEF LINE HEATER 3 (C21)
- DEF QUALITY/TEMP/LEVEL SENSOR (C24)