

---

Cooling System Installation

# Cooling System Installation

Item	Part No.	Qty	Description	Item	Part No.	Qty	Description
<b>602023 Cooling System Installation</b>							
1.1	* 602106	1	. Cooling Assembly	1.14	Y17C-1036	13	. Capscrew
1.2	601289	2	. Plate, Door Stop	1.15	221763W	22	. Washer
1.3	590052	2	. Stop, Door	1.16	234271	23	. Washer
1.4	R833218	1	. Fitting	1.17	15113W	20	. Locknut
1.5	231452	1	. Fitting	1.18	Y17D-10	10	. Locknut
1.6	594450	1	. Fitting	1.19	602557	1	. Fitting
1.7	23390	1	. Kit, Split Flange	1.20	253983	1	. Ball Valve
	203523	1	. O-Ring	1.21	603646	2	. Plate, Baffle
	209539	2	. Clamp Half	1.22	248148-39.50	2	. Trim, Edge
1.8	219321	4	. T-Bolt Clamp	1.99	602421	1	. Kit, Hose
1.9	256890	10	. U-Bolt	1.99.1	258951-33	1	. Hose Suction
1.10	231537	5	. Clamp	1.99.2	602856	1	. Hose Assembly
1.11	CLP0100112	6	. Clamp, Hydra-Zorb	1.99.3	602854	1	. Hose Assembly
1.12	255588	3	. Clamp, Hydra-Zorb	1.99.4	602855	1	. Hose Assembly
1.13	R13810989	2	. Capscrew				

\* See Separate Coverage

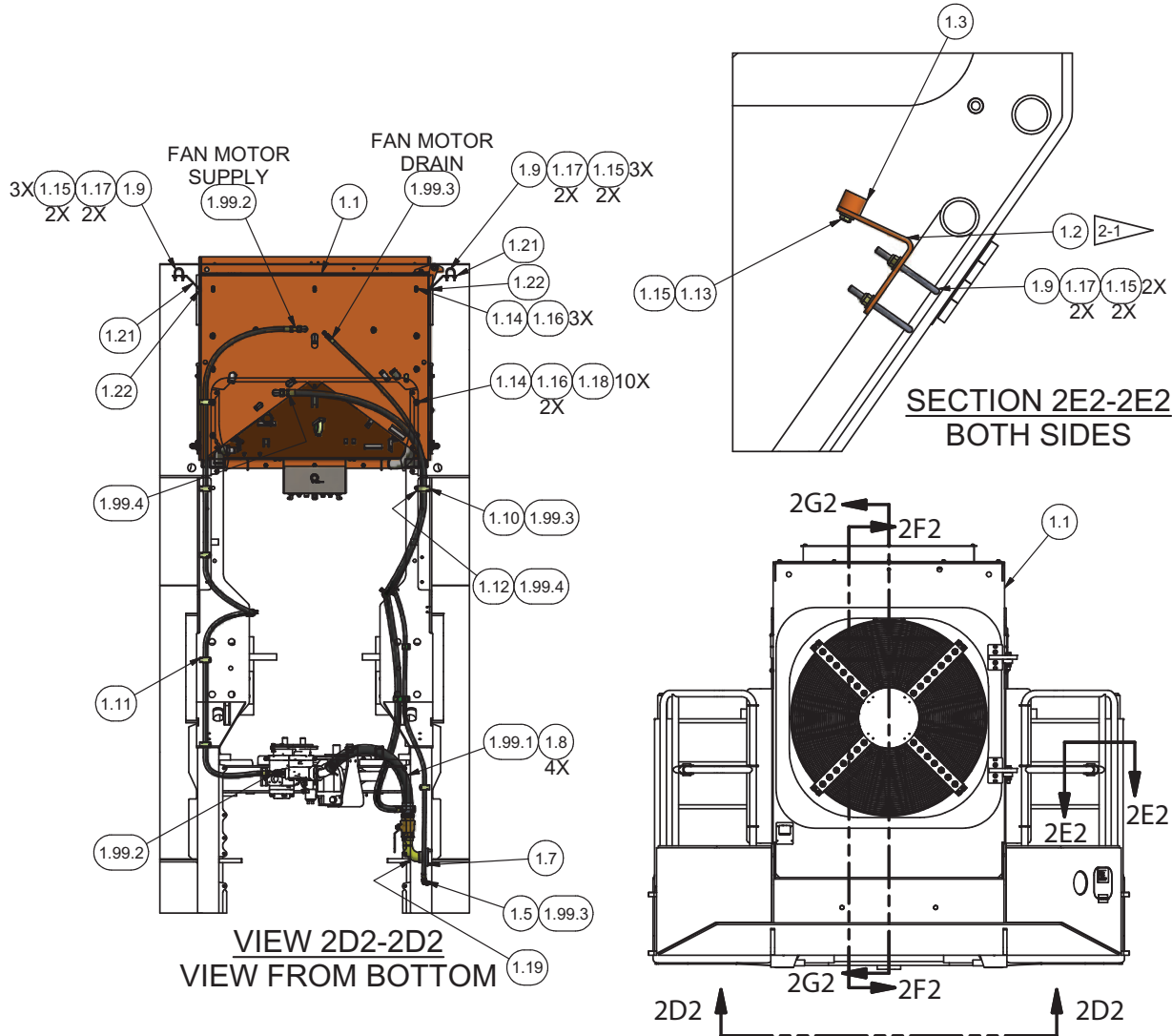

NOTES:  
2-1: LOCATE ALONG HANDRAIL TO PREVENT THE COOLING BOX DOOR FROM CONTACTING THE HANDRAIL.

# Cooling System Installation

