

---

Power Unit Installation

## Power Unit Installation

Item	Part No.	Qty	Description	Item	Part No.	Qty	Description
	<b>600987</b>		<b>Power Unit Installation</b>				
1	* 601052	1	. Power Unit Assembly	61	595496	1	. Fitting
2	234497	5	. Vibration Dampener	62	2510143	1	. Fitting
3	230682W	4	. Capscrew	63	2514292	1	. Fitting
4	578361	10	. Washer	64	591648	1	. Ball Valve
5	R13811196	5	. Locknut	66	209080	1	. Fitting
6	293708W	4	. Capscrew	71	206289	2	. Hose Clamp
7	293714W	4	. Capscrew	72	CLP7051171	4	. Mini Worm Drive Clamp
8	221777W	20	. Washer	74	238429	7	. Clamp
9	302405W	4	. Locknut	75	231296	3	. Clamp
10	231537	7	. Clamp	76	231250	5	. Clamp
11	293629W	3	. Capscrew	77	231249	1	. Clamp
12	251967	4	. Capscrew	78	231248	1	. Clamp
13	R13811432	55	. Washer	79	599486	1	. Plate, Isolator Mount
14	R13808094	1	. Clip, Insulated	80	599489	1	. Tail Support
15	R13802914	4	. Washer	81	599488	1	. Coil Spring
16	221767W	5	. Washer	82	599487	1	. Rod
17	598218	1	. Fill Cap Holder	83	234271	1	. Washer
18	208202	1	. Cap	84	Y17C-1028	1	. Capscrew
19	209820	1	. Fitting	85	221716W	4	. Hex Nut
20	230464	1	. Hose End	86	238381	2	. Jam Nut
21	606204	1	. Dipstick Housing	87	208242	2	. Elbow
22	243585	1	. Fitting	88	569792	1	. Tube, Exhaust
23	605251	1	. Dipstick	89	600290	1	. Tube, Flex
24	231251	1	. Clamp	90	600293	1	. Tube, CAC
25	293628W	25	. Capscrew	91	600294	2	. Hump Hose, Hot Side
26	302401W	18	. Locknut	92	589479	1	. Reducer, Exhaust
27	599724	1	. Bulkhead	93	226586	5	. Seal Clamp
28	598107	1	. Bulkhead	94	17100018	1	. Gauge, Sight Level
29	* 598103	1	. Assembly, Panel	95	597124	2	. Adaptor
30	600280	1	. Panel	96	209087	1	. Fitting
31	R13811210	14	. Capscrew	97	2510224	1	. Fitting
32	600292	1	. Tube, CAC	98	226552	1	. Fitting
33	600291	1	. Tube, CAC	99	209486	2	. Fitting
34	243488	4	. Connector	100	225640	2	. T-Bolt Clamp
35	600567	1	. Fitting	101	600323	1	. Reducer Elbow
36	243489	8	. Clamp	102	597116	1	. Decal, Eng Oil Level
37	2512841	1	. Fitting	199	600322	1	. Kit, Hose
38	209511	4	. Fitting	199.1	592605-116	1	.. Hose, Coolant
39	600305	1	. Plate, Support	199.2	592605-96	1	.. Hose, Coolant
40	598222	1	. Tube, Radiator	199.3	23551-27	1	.. Hose
41	209405	1	. Fitting	199.4	592088	1	.. Hose, Radiator
42	23543	2	. Fitting	199.5	211791-15	1	.. Hose, Radiator
43	241688	1	. Hose, Molded Elbow	199.6	219460-4	1	.. Hose, Radiator
44	225369	6	. T-Bolt Clamp	199.7	600319	1	.. Hose Assembly, Fuel
45	YDHA 8212-37.00	1	. Tube	199.8	600321	1	.. Hose Assembly, Fuel
46	598257	1	. Mount, Air Intake	199.9	600310	1	.. Hose Assembly, Fuel
47	209166	1	. Fitting	199.10	594222	1	.. Hose Assembly, Fuel
48	224354	1	. Elbow	199.11	598250	1	.. Hose Assembly, Fuel
49	217577	1	. Fitting	199.12	599760	1	.. Hose Assembly, Fuel
50	248819	1	. Fitting	199.13	599761	1	.. Hose Assembly, Fuel
51	2519048	1	. Fitting	199.14	600311	1	.. Hose Assembly, Fuel
52	216609	2	. T-Bolt Clamp	199.15	600312	1	.. Hose Assembly, Fuel
53	207245	1	. T-Bolt Clamp	199.16	600313	1	.. Hose Assembly, Fuel
54	224199	1	. T-Bolt Clamp	199.17	600568	1	.. Hose Assembly, Fuel
55	206207	4	. Hose Clamp	199.18	600569	1	.. Hose Assembly, Fuel
56	216494	1	. T-Bolt Clamp	199.19	210236	1	.. Hose Assembly
59	592029	1	. Fitting	199.20	207855	1	.. Hose Assembly
60	598178	1	. Fitting				

\* See Separate Coverage

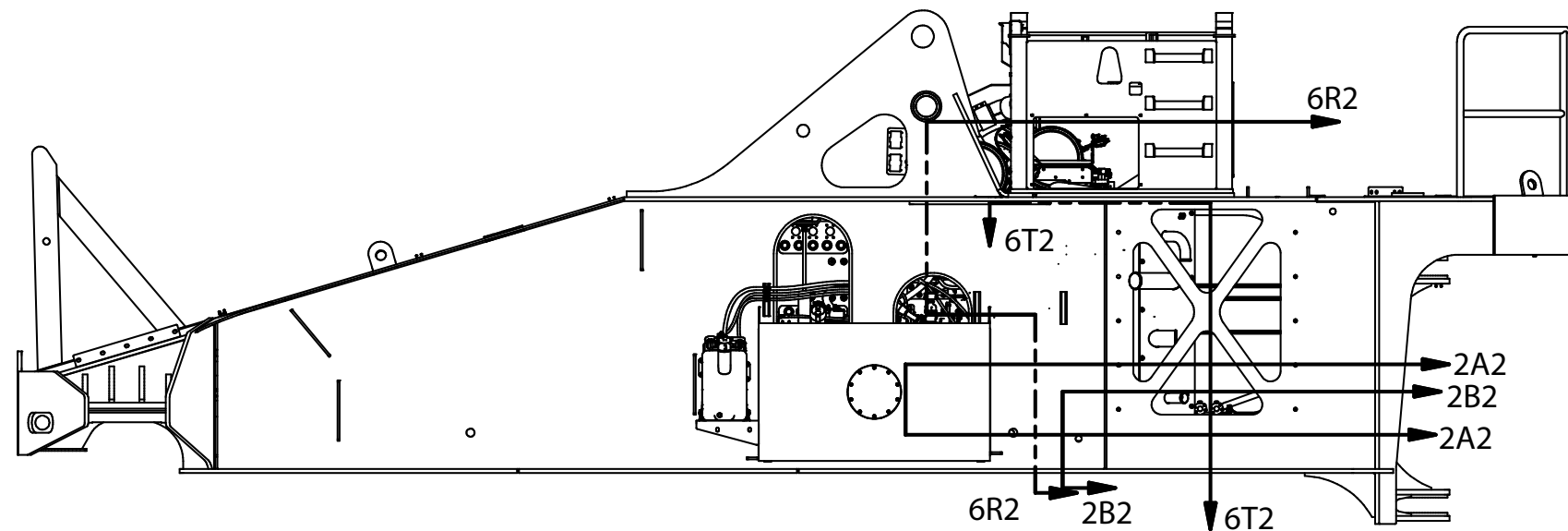
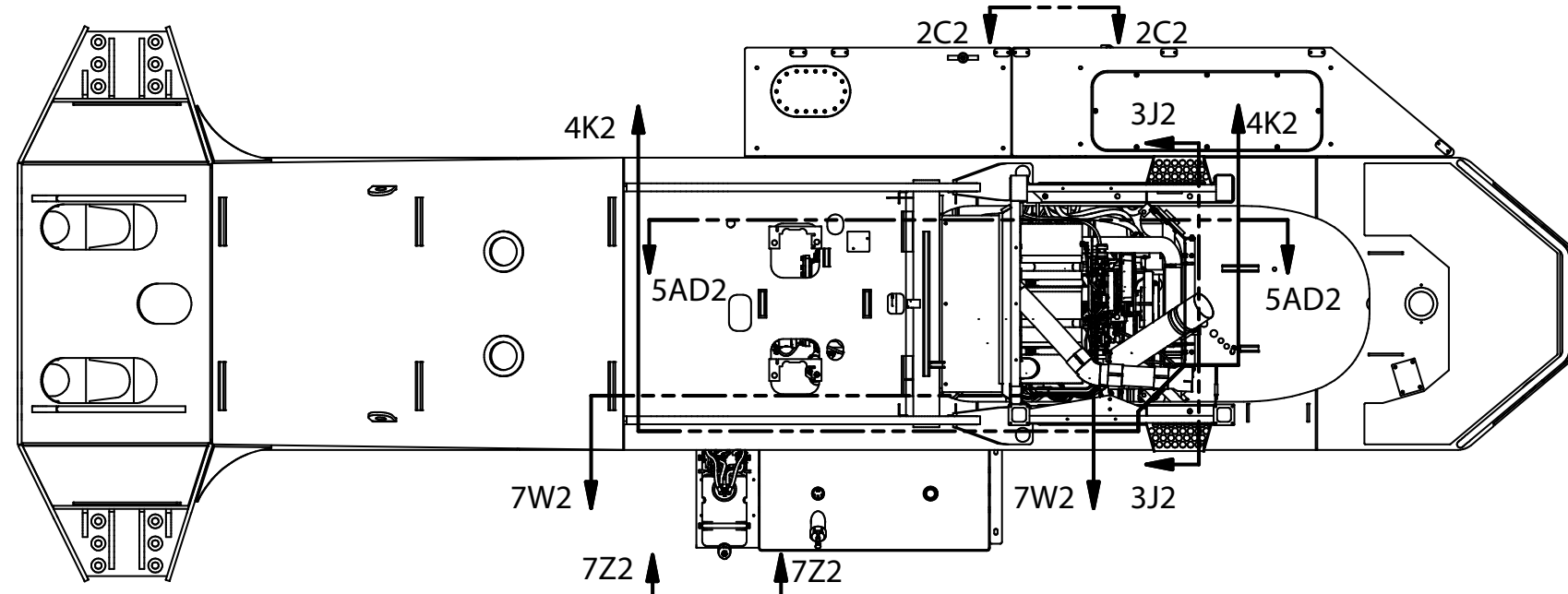
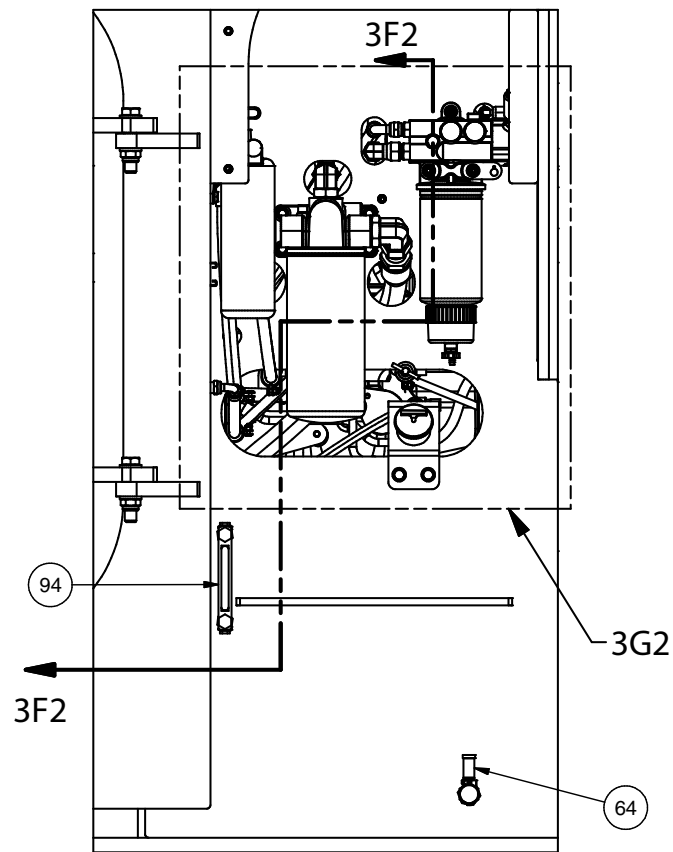
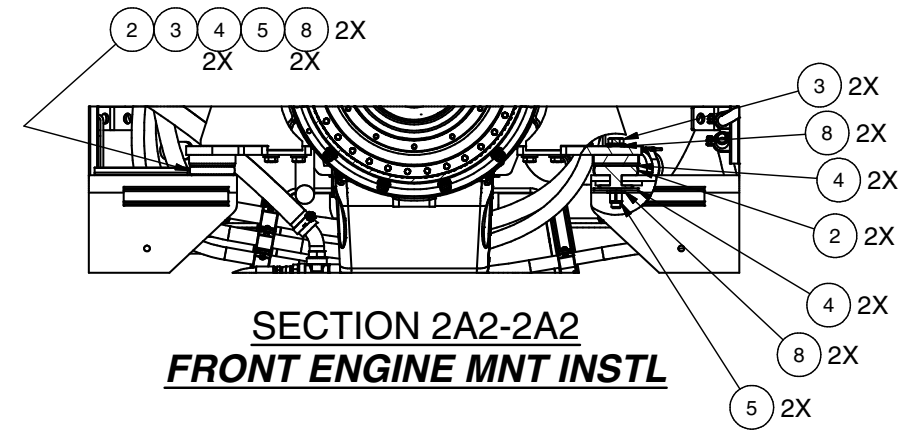
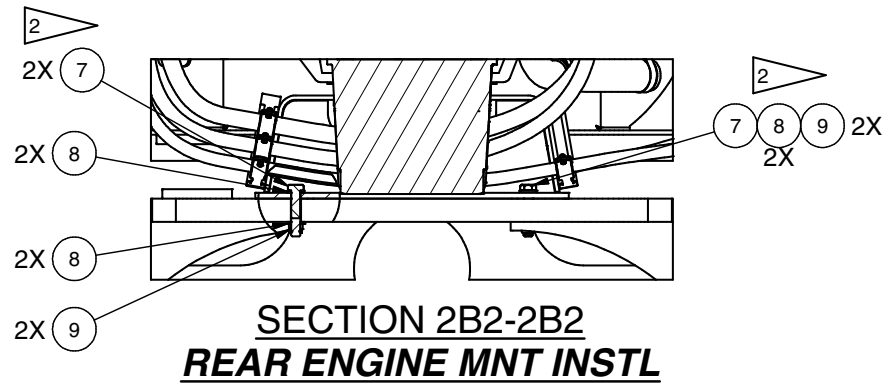

2 LONG BOLTS ( ITEM 7- 293714W ) FOR 4WD  
SHORT BOLTS ( ITEM 6- 293708W ) FOR 2WD

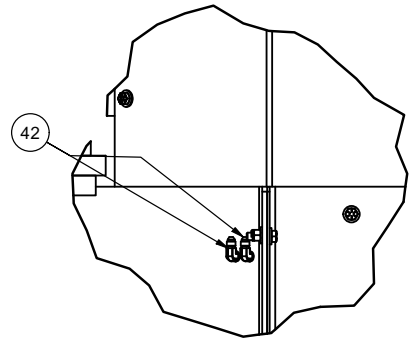

**DETAIL 3E3  
COOLANT VENT LINE  
BULKHEAD FITTINGS**

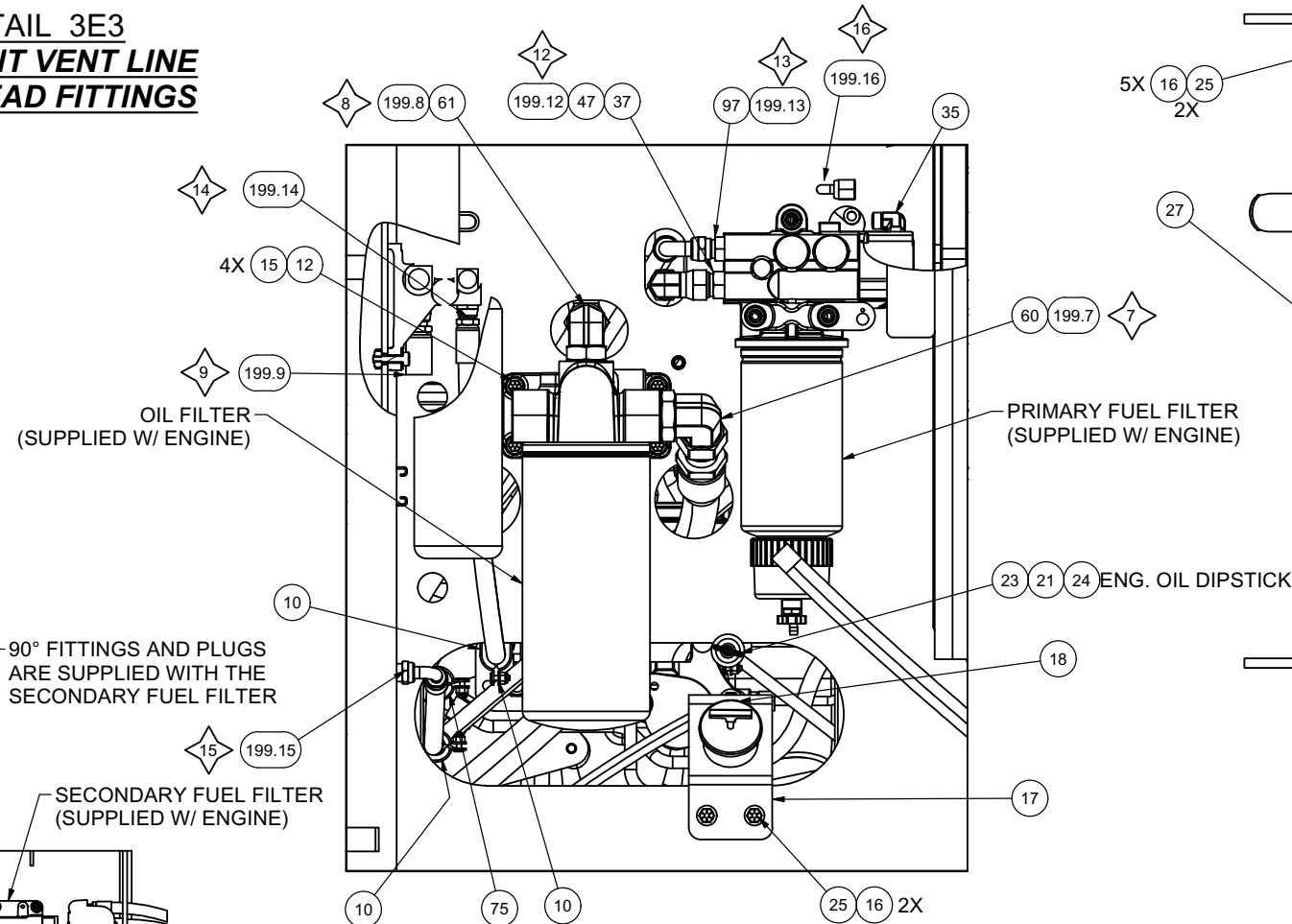

**DETAIL 3G2  
OIL FILTER/ FUEL FILTER INSTL**

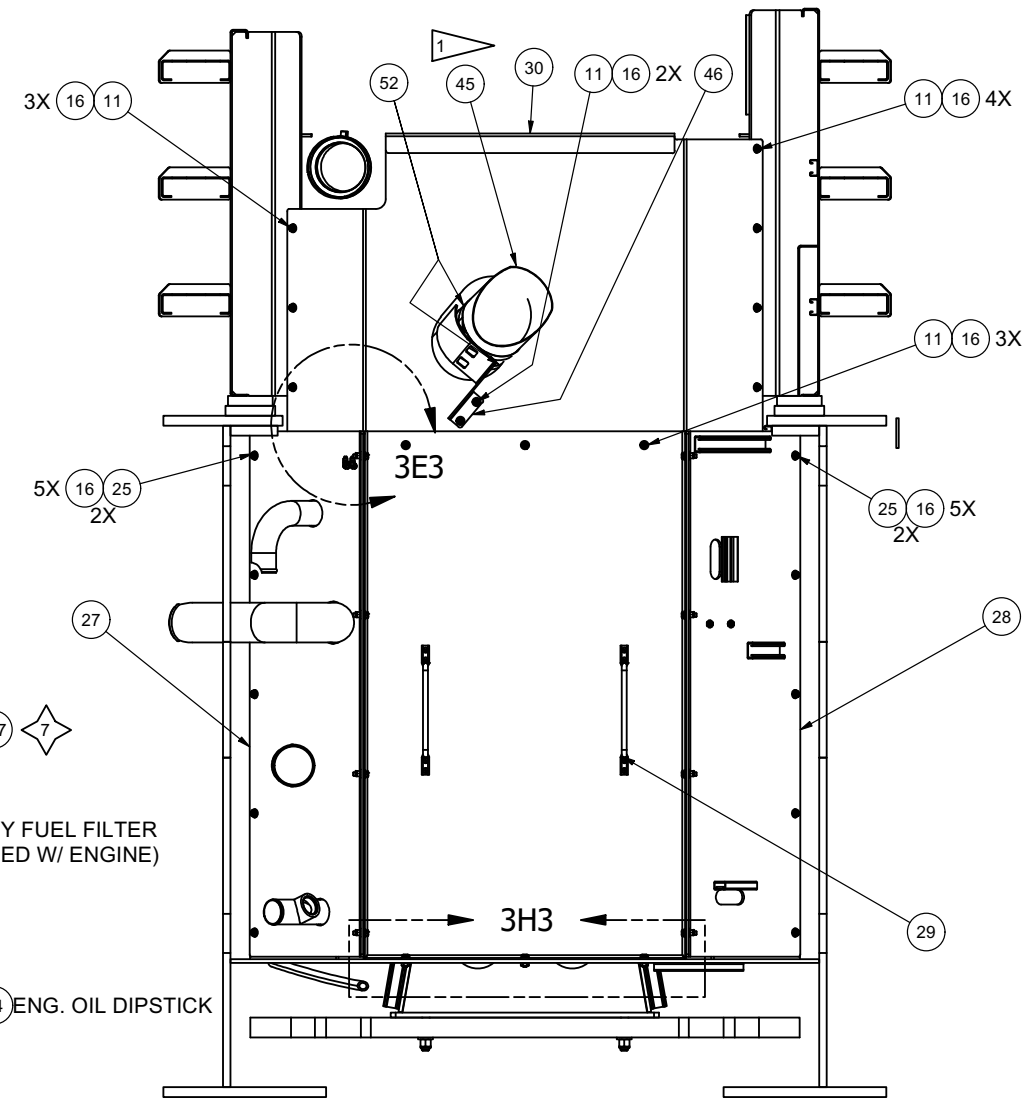

**SECTION 3J2-3J2  
BULKHEAD/ISOLATION PLATE INSTL  
VIEW ROTATED 90°**

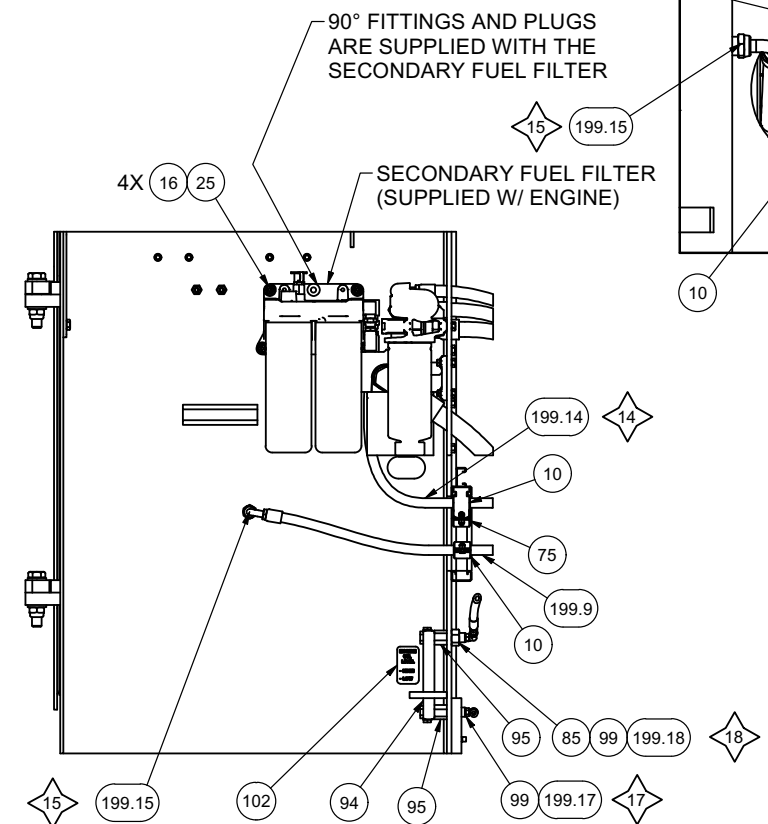

**SECTION 3F2-3F2**

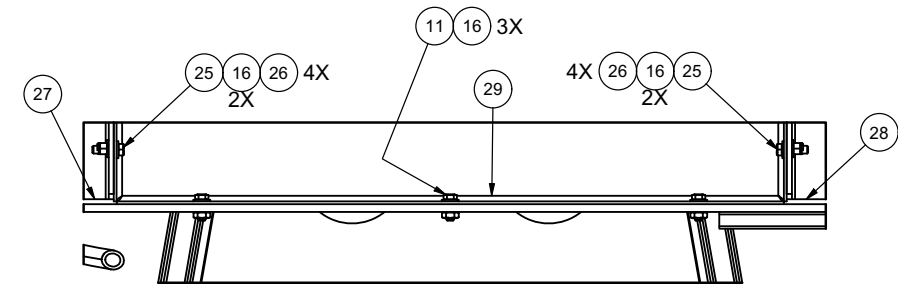

**DETAIL 3H3**

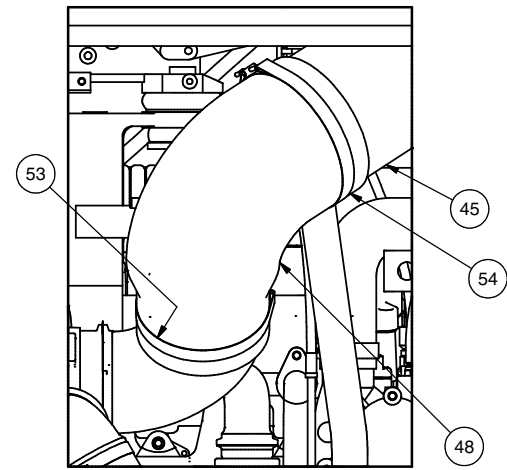

**DETAIL 4P4**  
**AIR CLEANER INSTL**  
**COMPONENTS REMOVED FOR CLARITY**

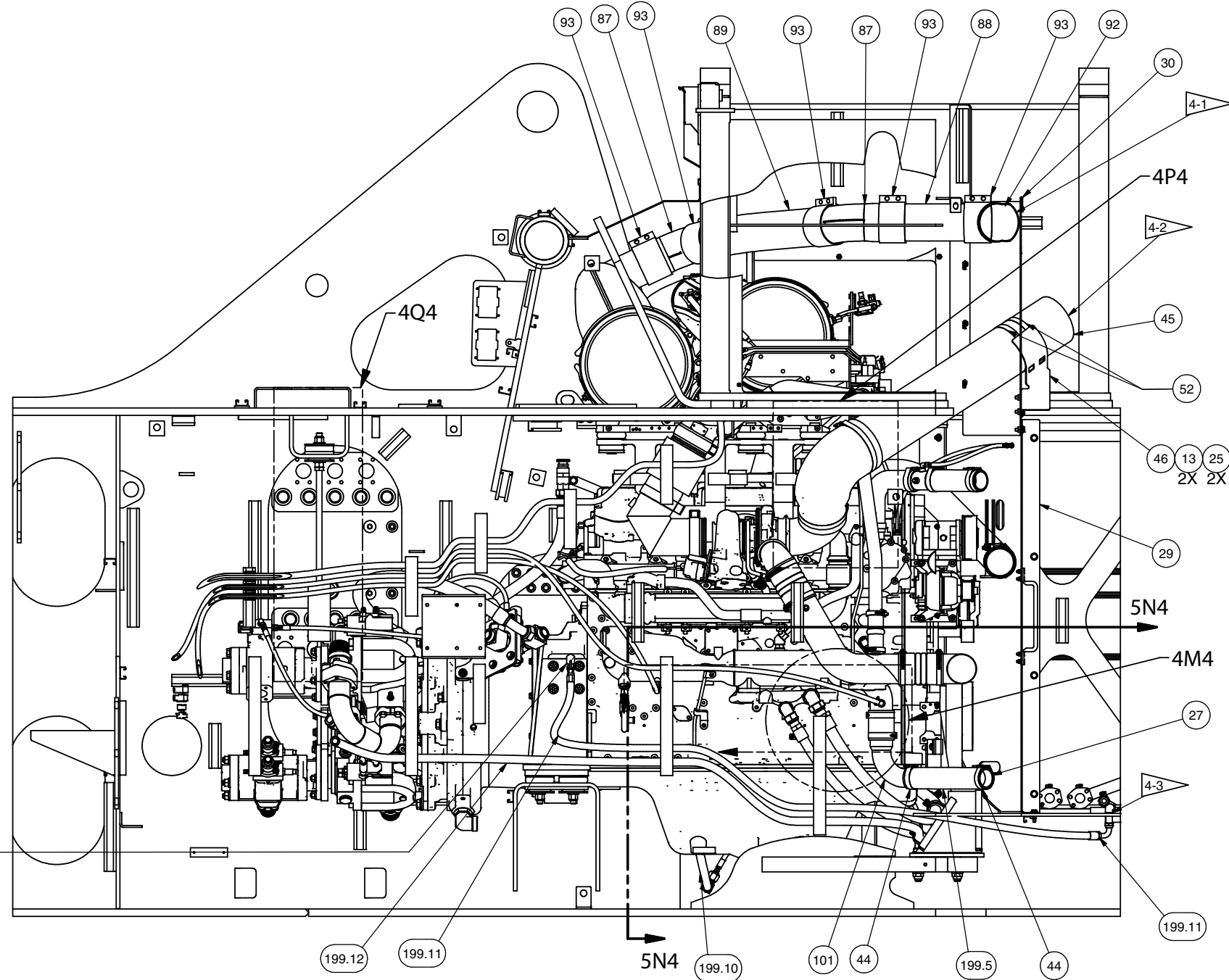

**SECTION 4K2-4K2**  
**COMPONENTS REMOVED FOR CLARITY**

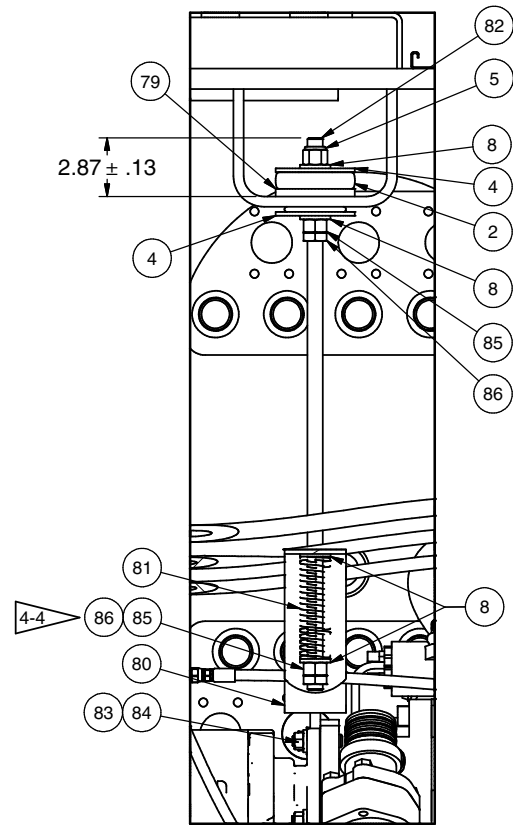

**DETAIL 4Q4**

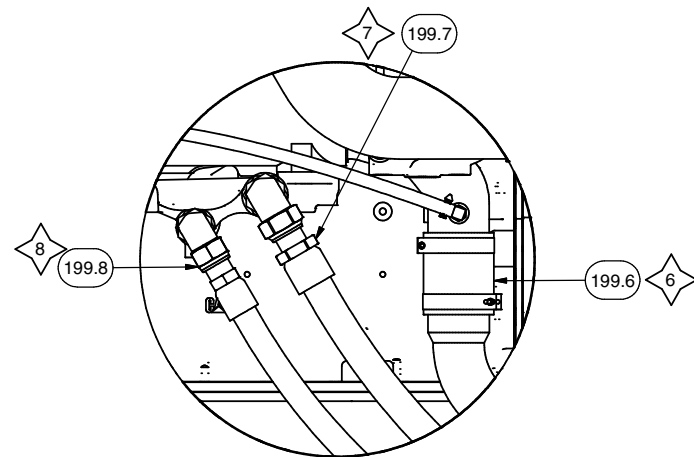

**DETAIL 4M4**  
**OIL FILTER LINES (ENGINE SIDE)**

**NOTES:**

- 4-1 EXHAUST ROUTING CONTINUED ON EXHAUST INSTALLATION.
- 4-2 AIR INTAKE ROUTING CONTINUED ON AIR INTAKE INSTALLATION.
- 4-3 FUEL LINE ROUTING CONTINUED ON COOLING PACKAGE INSTALLATION.
- 4-4 AFTER PRE-LOADING ISO-MOUNT, TIGHTEN ITEM 84 (NUT) UNTIL ITEM 80 (SPRING) COMPRESSES 1.00" (SPRING COMPRESSED LENGTH OF 4.00"). THIS WILL APPLY APPROXIMATELY 210 LBS OF UPWARD SUPPORT ON THE REAR FLANGE OF HYDRAULIC PUMP FLANGE.



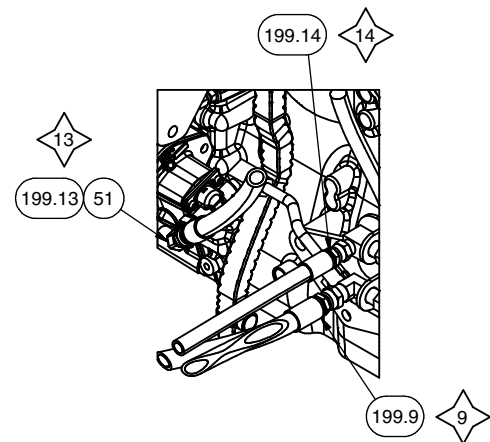

**ISO VIEW OF DETAIL 6S6**

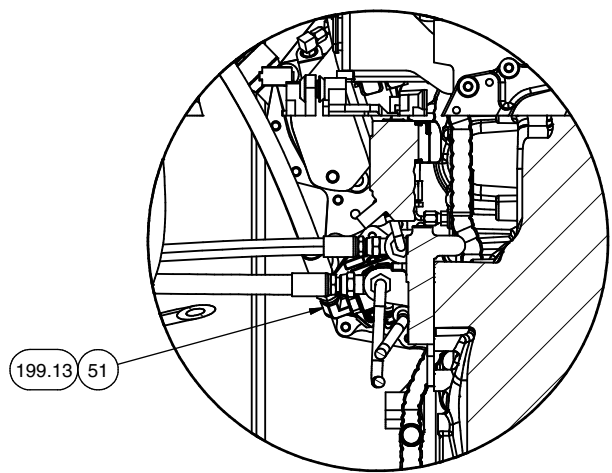

**DETAIL 6S6  
FUEL FILTER PLUMBING  
(ENGINE SIDE)**

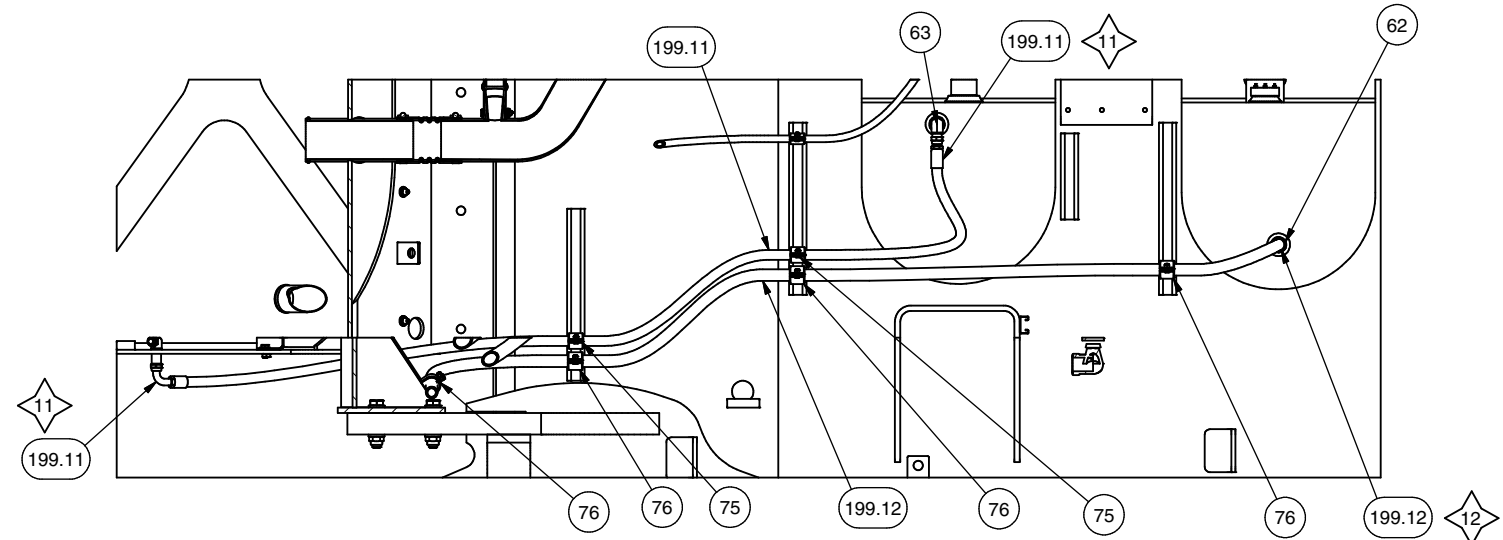

**SECTION 6U6-6U6  
FUEL LINE ROUTING**

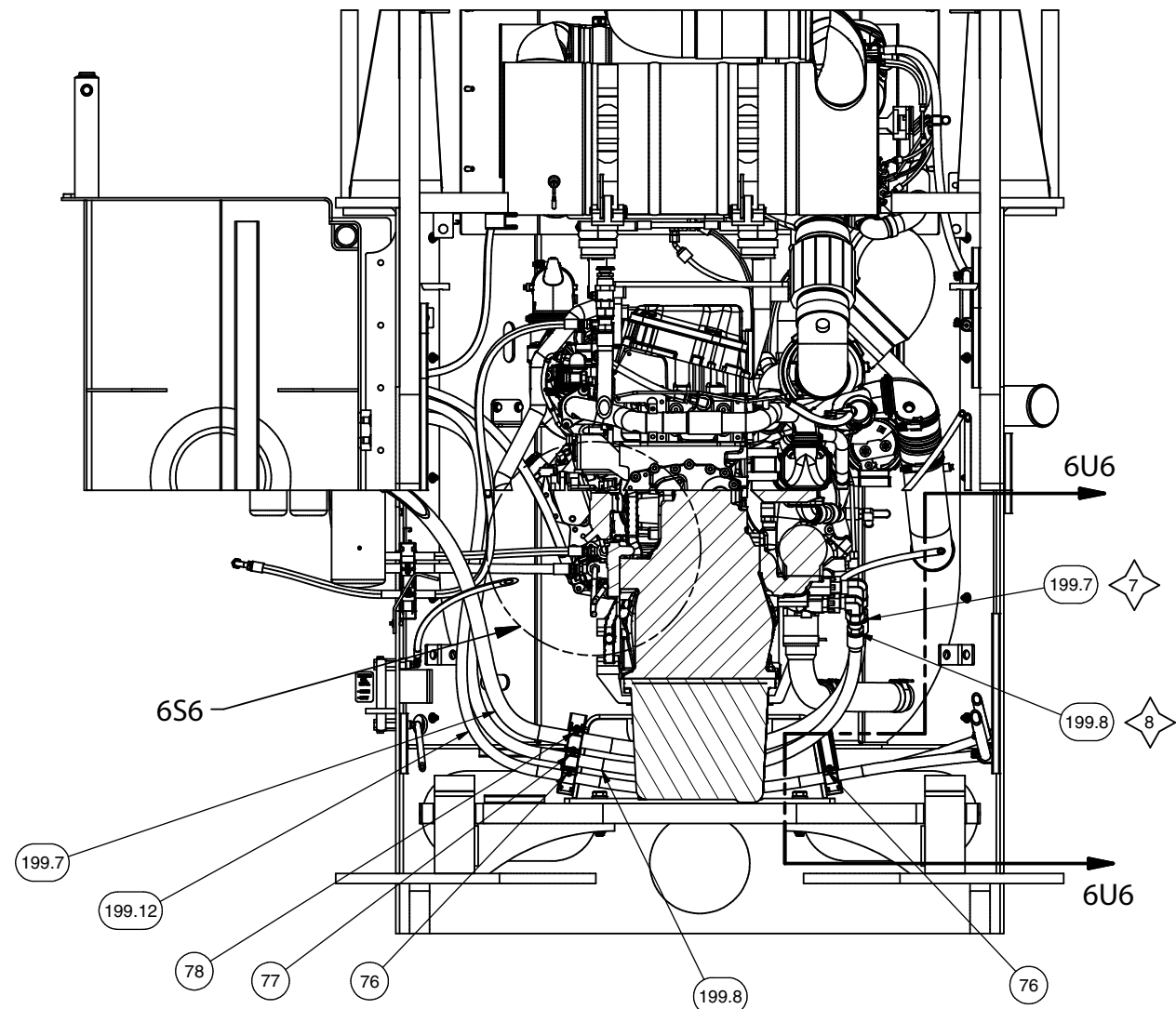

**SECTION 6R2-6R2  
PLUMBING INSTL  
ITEMS REMOVED FOR CLARITY**

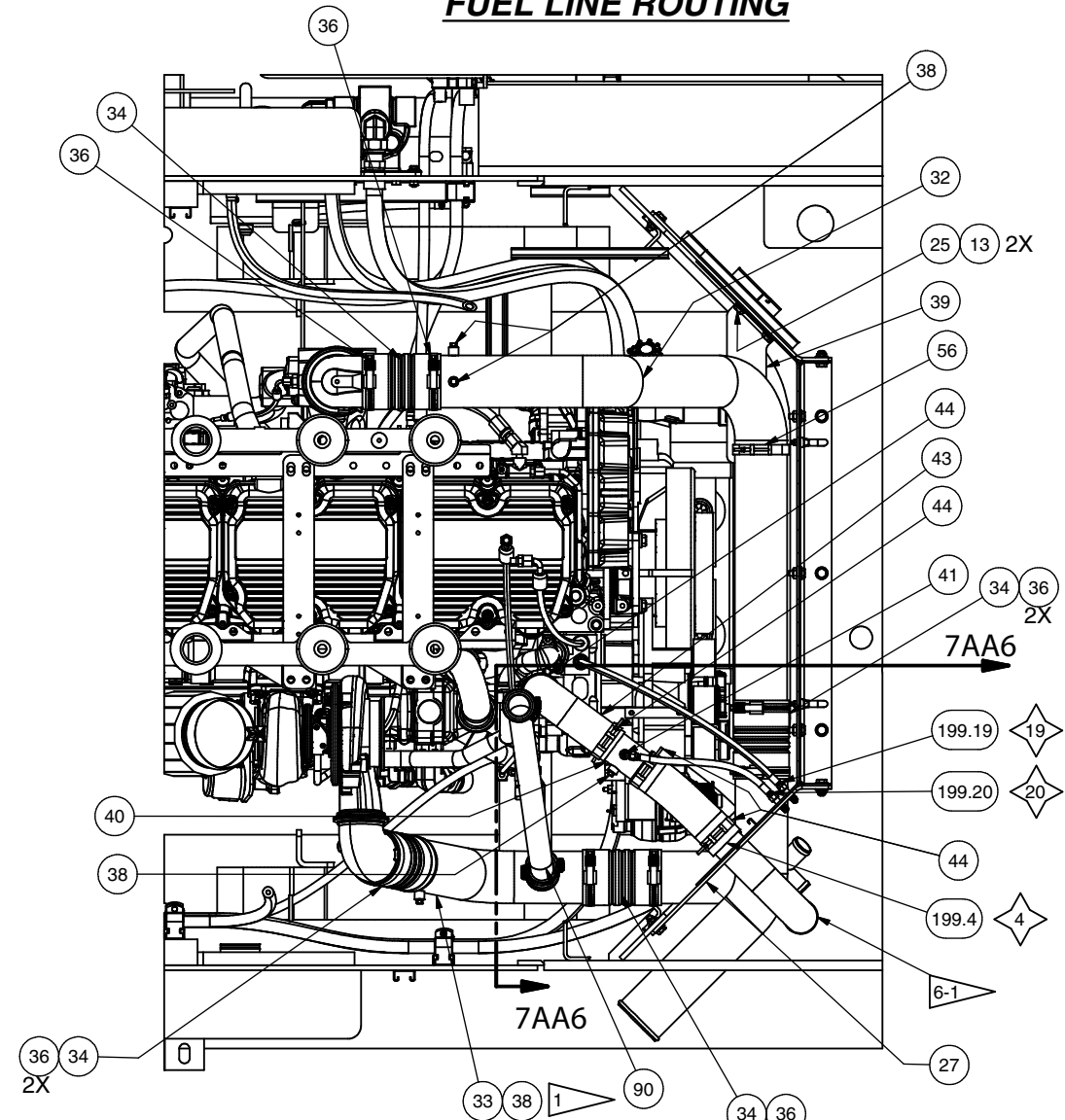

**SECTION 6T2-6T2  
CAC PLUMBING & JACKET WATER (HOT) INSTL  
COMPONENTS REMOVED FOR CLARITY**

**NOTES:**

6-1 CAC AND JACKET WATER ROUTING CONTINUED ON COOLING PACKAGE INSTALLATION.

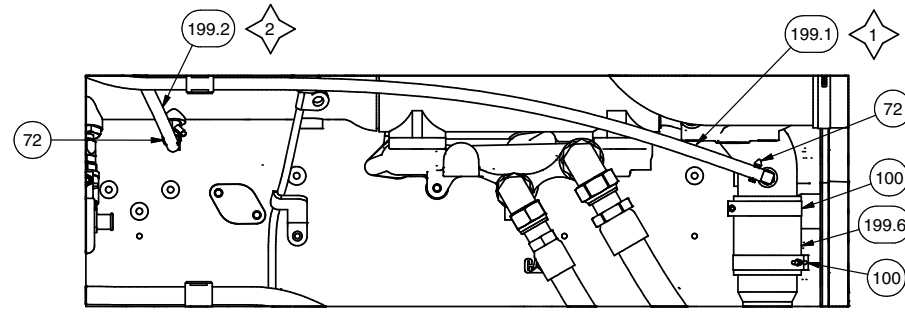

**DETAIL 7Y4  
DEF COOLANT ENGINE CONNECTIONS**

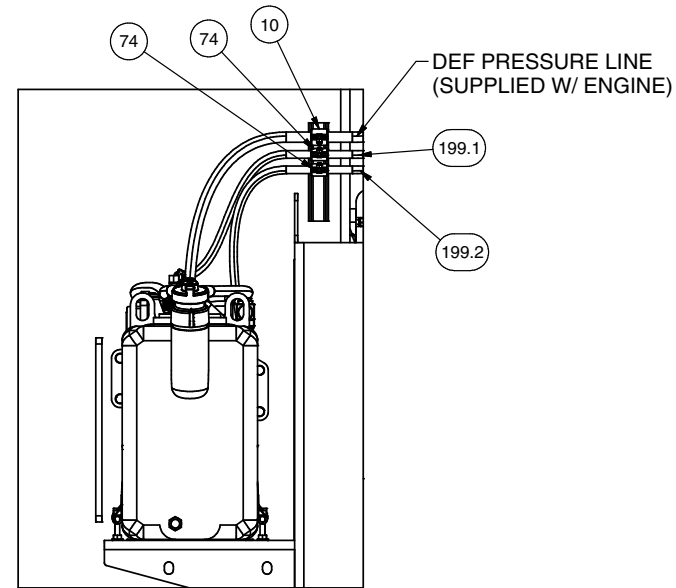
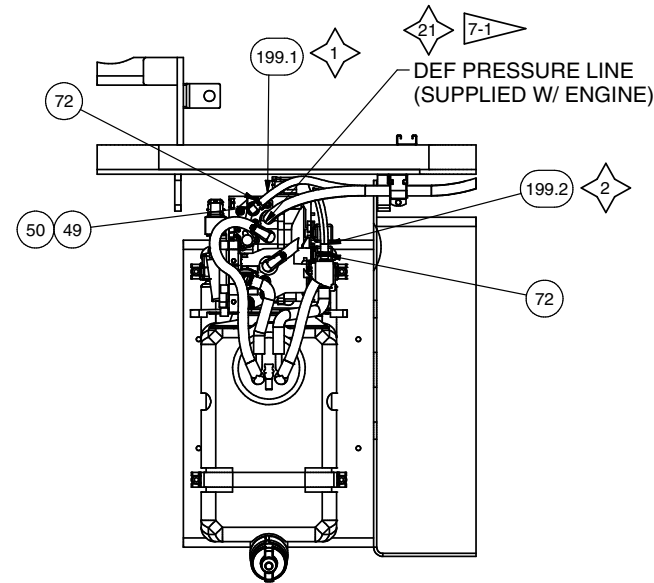

**VIEW 7Z2-7Z2  
DEF TANK INSTL/PLUMBING**

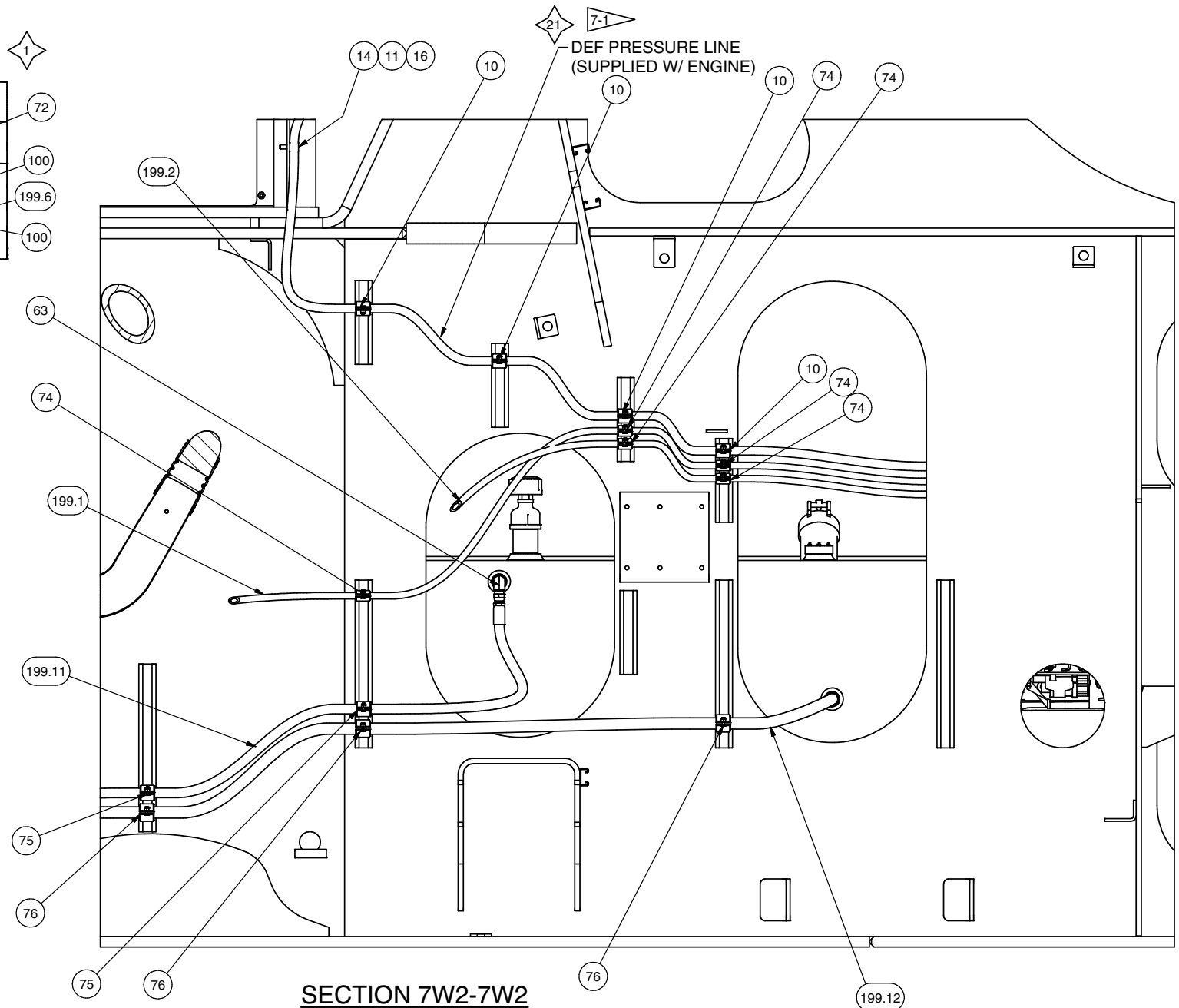

**SECTION 7W2-7W2  
DEF/COOLANT LINE PLUMBING**

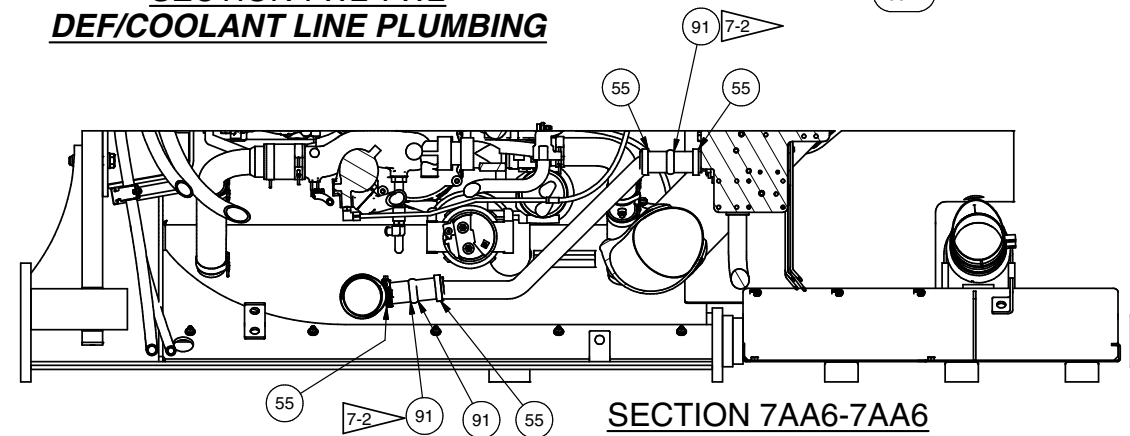

**SECTION 7AA6-7AA6**

**NOTES:**

- 7-1 LOCATE ELECTRICAL CONNECTION END OF DEF LINES CLOSEST TO THE DEF TANK.
- 7-2 TRIM HUMP HOSE (ITEM #91) AS REQUIRED TO FIT



◆ & THE ROUTING TABLE DETAIL THE START AND END OF HOSE ROUTINGS.  
USE ROUTING TABLE WHEN INSTALLING ITEM 199 HOSE KIT.

ROUTE NO.	FROM	TO
1	DEF TANK COOLANT OUTLET	JACKET WATER INLET BOTTOM OF ENGINE
2	DEF COOLANT SUPPLY PORT ENGINE	DEF TANK COOLANT INLET
3	RH CHASSIS SIDE ENGINE OIL FILL	ENGINE OIL PAN
4	JACKET WATER OUTLET TOP OF ENGINE	RAD/CAC BULKHEAD WELDMENT RAD TUBE
5	REDUCER ELBOW (ITEM 101)	RAD/CAC BULKHEAD WELDMENT RAD TUBE
6	JACKET WATER INLET BOTTOM OF ENGINE	REDUCER ELBOW (ITEM 101)
7	OIL FILTER OUTLET PORT ON ENGINE	RH CHASSIS SIDE OIL FILTER INLET
8	RH CHASSIS SIDE OIL FILTER OUTLET	OIL FILTER INLET PORT ON ENGINE
9	ENGINE FUEL OUTLET	SECONDARY FUEL FILTER INLET
10	RH CHASSIS Q.D. REMOTE OIL FILL	ENGINE OIL PAN DRAIN
11	LOWER CHASSIS BULKHEAD PLATE FROM FUEL COOLER	FUEL TANK INLET PORT
12	FUEL TANK OUTLET	PRIMARY FUEL FILTER INLET
13	PRIMARY FUEL FILTER OUTLET	FUEL PUMP INLET
14	SECONDARY FUEL FILTER OUTLET	ENGINE FUEL INLET
15	ENGINE FUEL OUTLET	RH SIDE COOLING BOX BULKHEAD TO FUEL COOLER
16	PRIMARY FUEL FILTER REGEN PUMP	CAT REGEN SYSTEM MANIFOLD ASSY
17	RH CHASSIS GAUGE SIGHT LEVEL	ENGINE OIL DRAIN
18	RH CHASSIS GAUGE SIGHT LEVEL	ENGINE CRANK CASE
19	ENGINE VENT PORT (TOP OF THERMOSTAT HOUSING)	RAD/CAC BULKHEAD WLDMT TO SURGE TANK
20	RAD TUBE VENT PORT (ITEM 40)	RAD/CAC BULKHEAD WLDMT TO SURGE TANK
21	DEF TANK SUPPLY	CEM DEF INLET

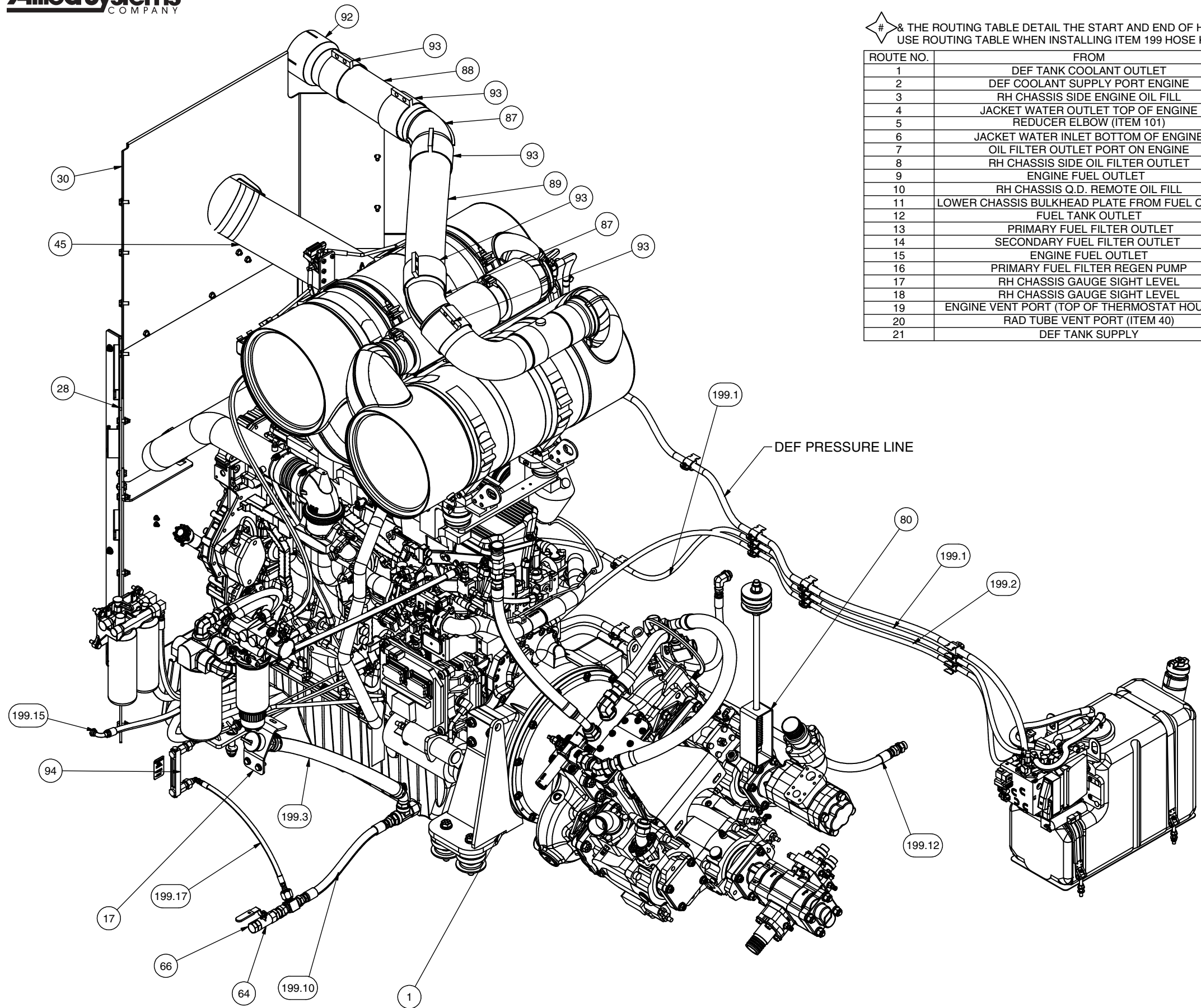

ISO TOP VIEW

