

CUMMINS QSX15 T4 ENGINE OPTION

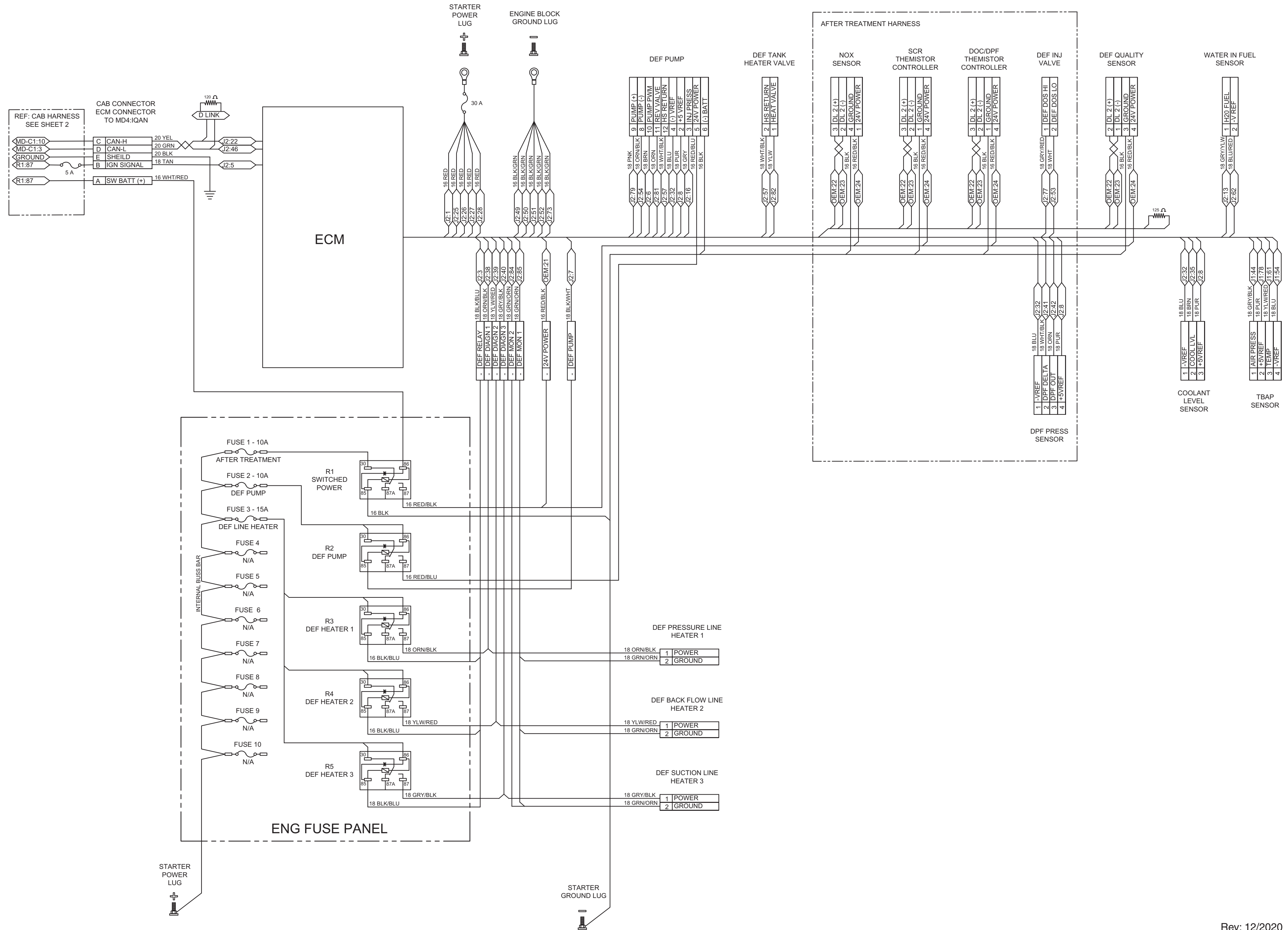

CAT C15 T4 ENGINE OPTION

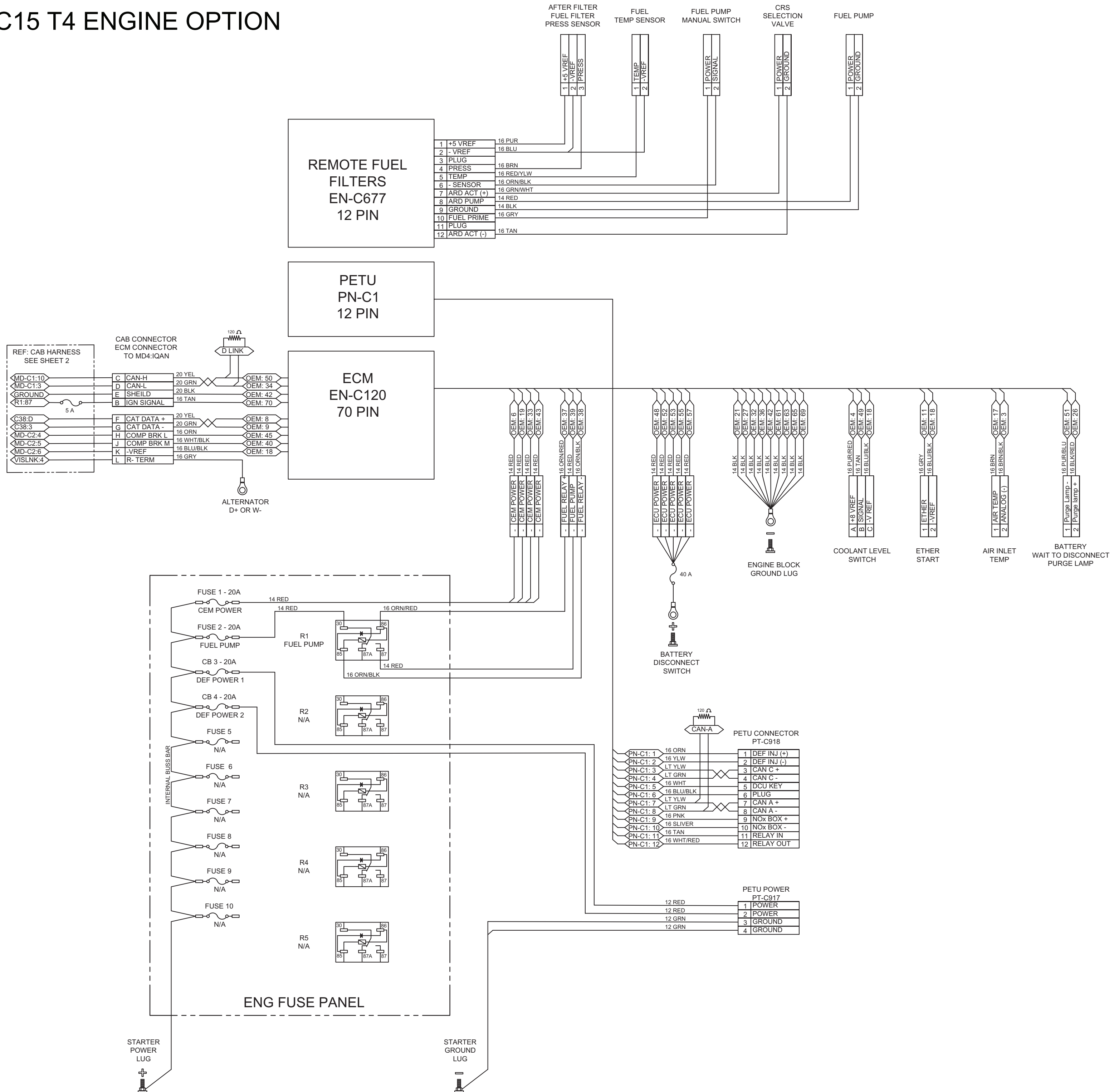

SCANIA OC16 T4 ENGINE OPTION

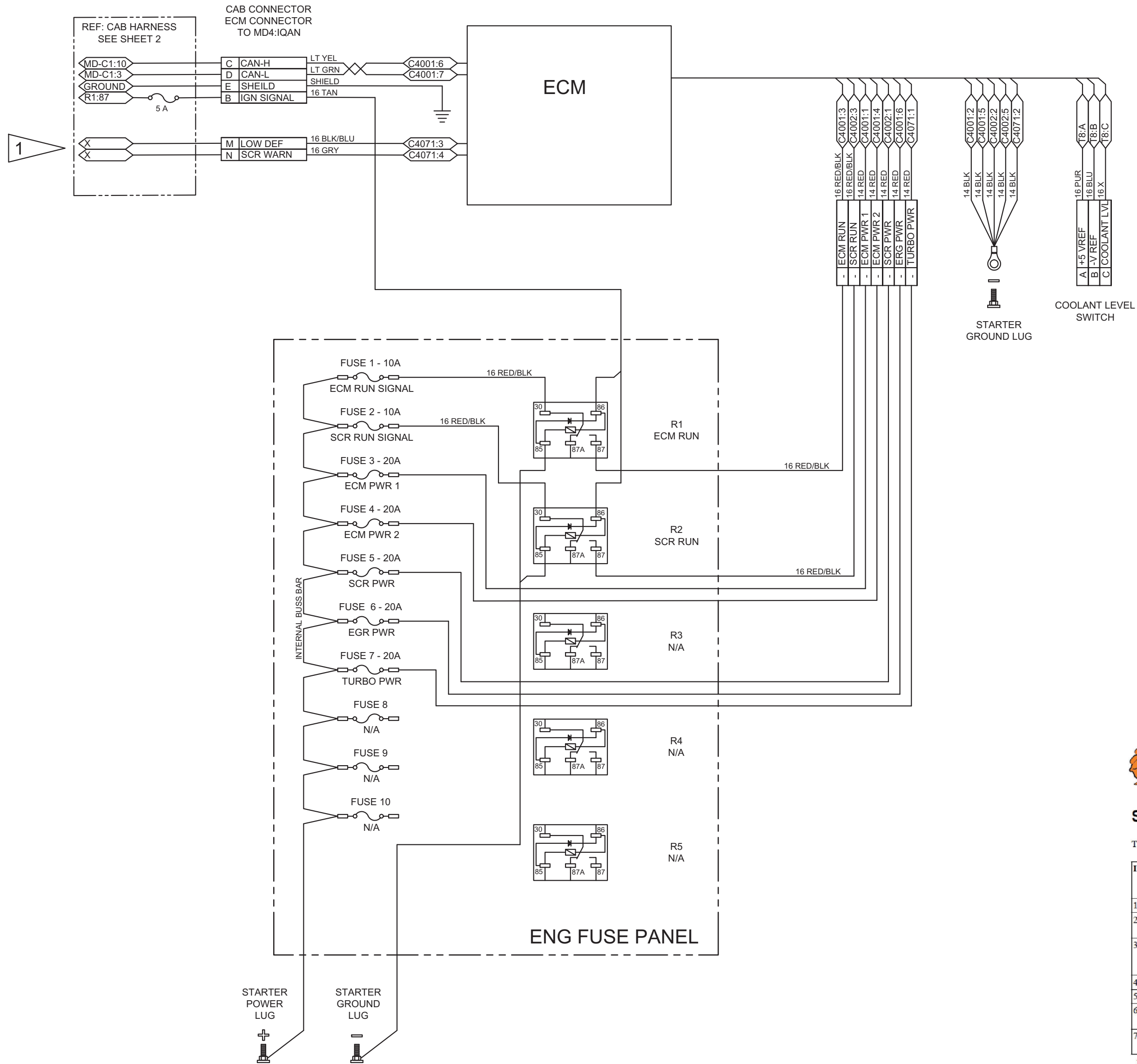

NOTES:
1. SCANIA SUPPLIED ENGINE HARNESSES AND INSTALLATION



INSTALLATION MANUAL

System overview of electrics

The illustration shows an overview of the electrical connections in the SCR system.

Item	Component	Supplied from the factory	Fitted by fitter
1	Engine interface for SCR system	X	
2	Cable harness between engine and SCR control unit	X	X
3	Electrical cable for NOx sensor in exhaust brake housing/exhaust pipe downstream of the turbocharger ¹	X	X
4	Electrical connection to SCR system	X	
5	Electrical cable for reductant doser	X	X
6	Electrical cable for exhaust gas temperature sensor	X	X
7	Electrical cable for NOx sensor on the outlet side of the SCR catalytic converter	X	X

1. Stage IV/Tier 4f only.

