Electrical System - Cab

Electrical System - Cab

Item	Part No.	Qty	Description	Item	Part No.	Qty	Description
	600324		Electrical System - Cab				
1	* 600332	1	. Assembly, Overhead Console	36	230839	1	. Connector, Cord
2	* 597914	1	. Assembly, Dash	38	234271	6	. Washer
3	* 597899	1	. Assembly, Panel - Front LH	39	Y17D-10	3	. Locknut
4	* 597898	1	. Assembly, Panel - Front RH	42	221767W	4	. Washer
6	598937	1	. Power Converter	43	221499W	2	. Capscrew
7	072-0073	1	. Latch, Lid Stay	44	Y17C-1028	3	. Capscrew
9	590865	1	. Remote Monitor	45	601057	1	. Antenna
10	598329	1	. Monitoring Module, Remote	46	586109	2	. Grommet, Rubber
11	R13803444	2	. Locknut	47	81905	11	. Grommet
12	R13812210	6	. Washer	48	242141	3	. Plug, Dome 3/4"
13	220446W	2	. Capscrew	49	598913	2	. Plug, Dome 9/16
14	596489	2	. Machine Screw	51	79603	1	. Module, Expansion
17	18699W	4	. Capscrew	52	65290	2	. Machine Screw
19	R13803445	2	. Locknut	53	WCT0000187	2	. Washer
20	R13812212	20	. Washer	54	* 600423	1	. Wiring, Cab
21	Y25G-(1024)10	16	. Capscrew	55	599681	1	. Wire Harness, "D"
23	R13806823	4	. Locknut		240519	1	. Thermistor, 1.3 Ohms
24	223428	10	. Washer		600615	2	. Relay, Mini Iso
25	R13801792	6	. Capscrew	56	593637	1	. Horn , Dual Trumpet
26	256319	1	. Receptacle	60	Y25G-(1024)12	2	. Capscrew
27	241295	1	. Receptacle	61	221763W	2	. Washer
28	R10581	1	. Stud, Battery Feeder	63	224120W	2	. Capscrew
29	241826	4	. Receptacle, Wedgelock	64	15113W	2	. Locknut
30	587704	1	. Rod	65	600080	1	. Bracket
31	Y10E-06	6	. Lockwasher	66	257424	2	. Magnet
32	221707W	2	. Hex Nut	67	591002	1	. Bracket
33	237567	2	. Locknut	68	R740836	1	. Nut
34	256320	1	. Light, Dome Red Led	69	601039	2	. Pad,Base
35	594067	2	. Speaker, Flush Mount				

* See Separate Coverage

NOTES:
* INSTALL PLUG UNLESS THE OPTION WILL BE INSTALLED, THEN INSTALL THE GROMMET. RETURN TO STOCK/SCRAP THE COMPONENTS NOT USED

1: ALL ROOF MOUNTED COMPONENTS ARE MAGNETIC SO THAT THEY CAN BE REMOVED FROM THE ROOF QUICKLY AND STORED ON THE BACK OF THE CAB.

2: WHEN ROUTING CABLES & WIRES TO THE ROOF. ALLOW WIRES TO DROOP SLIGHTLY BELOW THE GROMMET TO PREVENT WATER FROM FOLLOWING THE WIRES INTO THE CAB.

3 ATTACH THE BASE PAD ITEM 69 - 601039 TO THE BOTTOM OF THE MAGNET BASE USING 3M-HI STRENGTH 90 ADHESIVE. CENTER BASE PAD WITH AT LEAST 1/8" OF THE PAD SHOWING AROUND THE OUTSIDE OF THE MAGNET BASE.

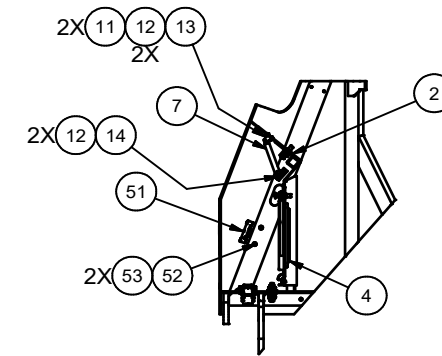
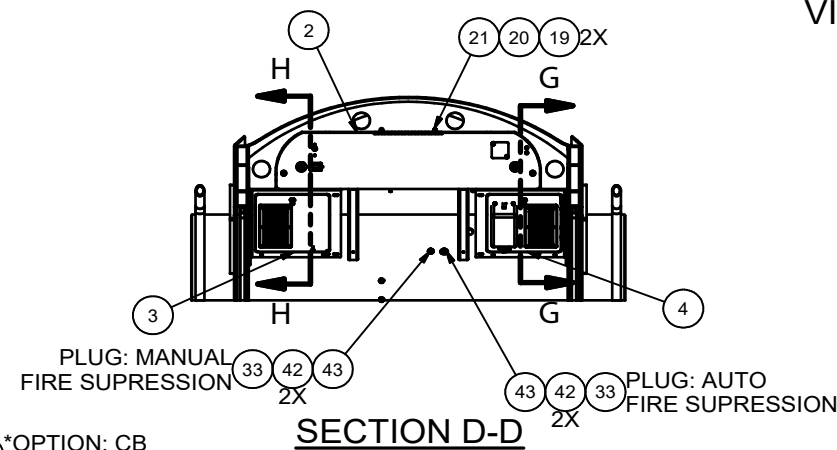
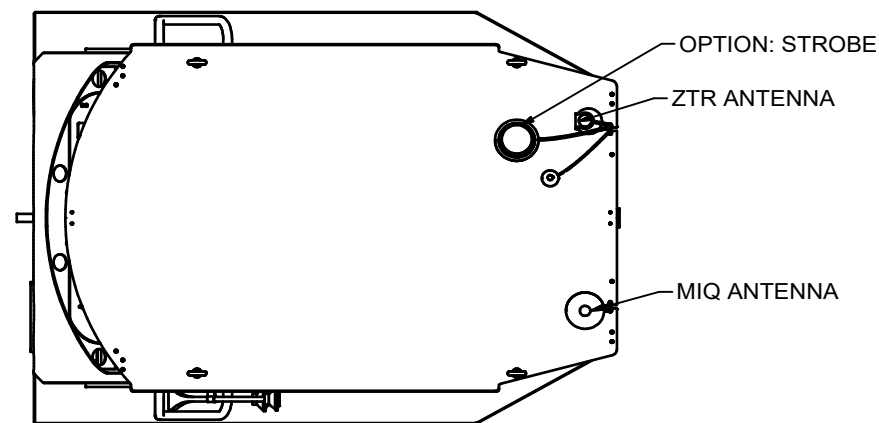

**SECTION G-G
VIEW ROTATED**

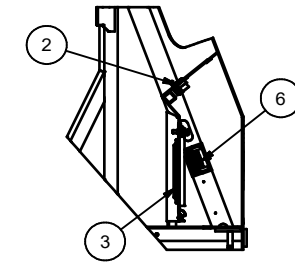

SECTION H-H

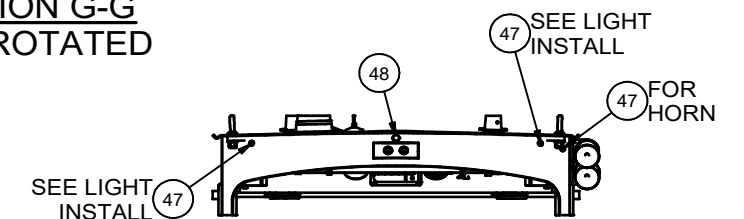

SECTION F-F

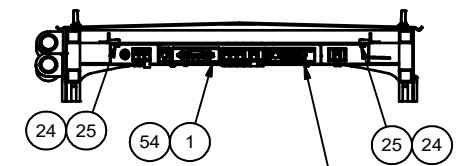

SECTION E-E

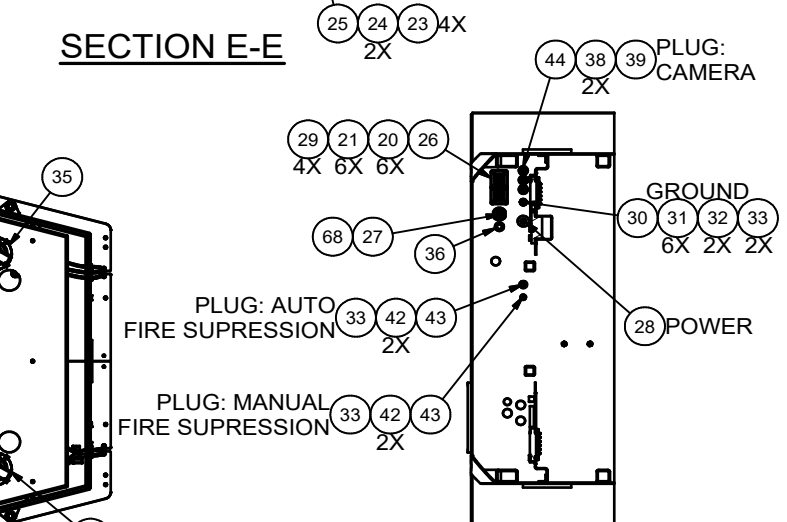

SECTION C-C

**SERVICE USE ONLY
LAST USED L120-255**

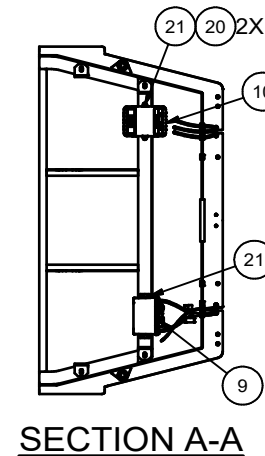
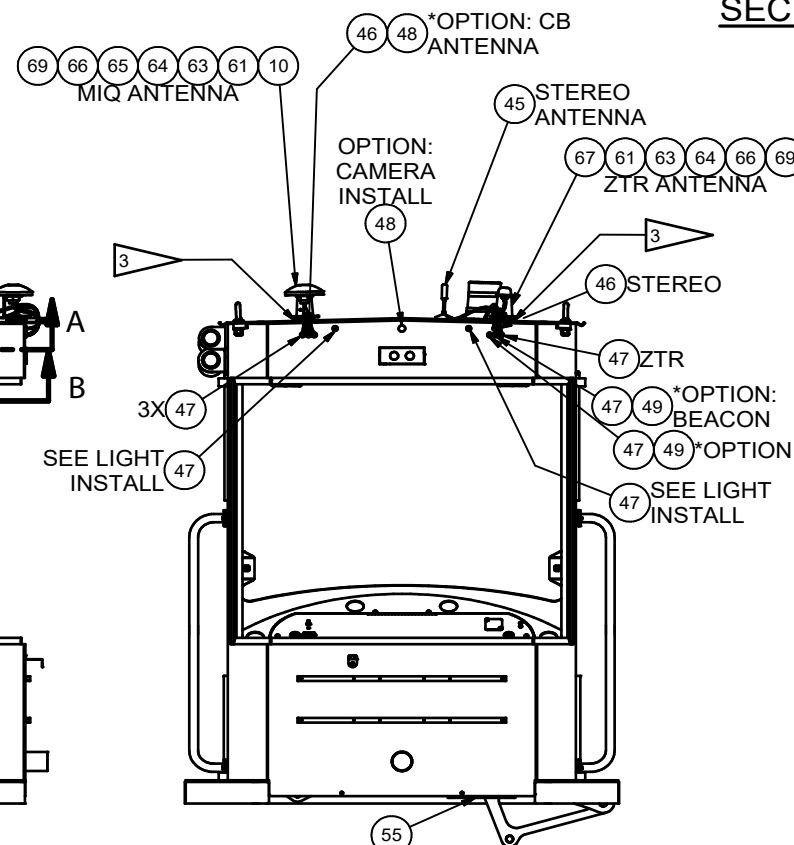
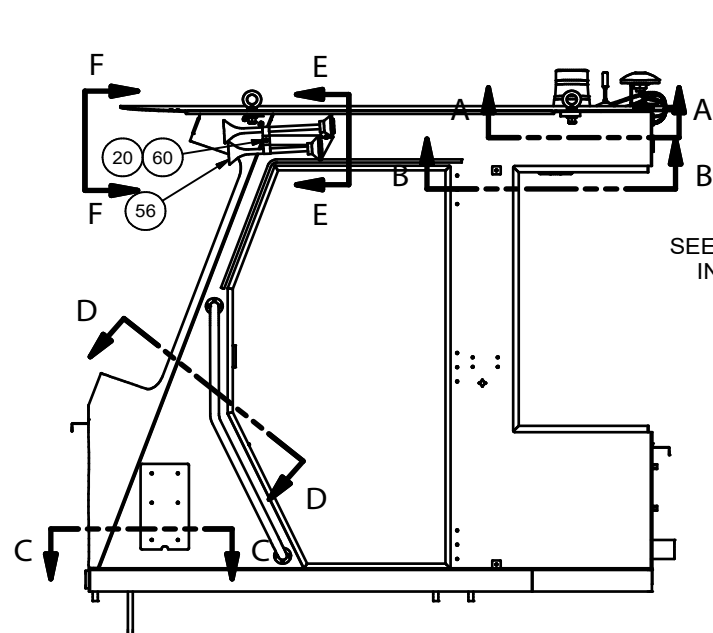

SECTION A-A

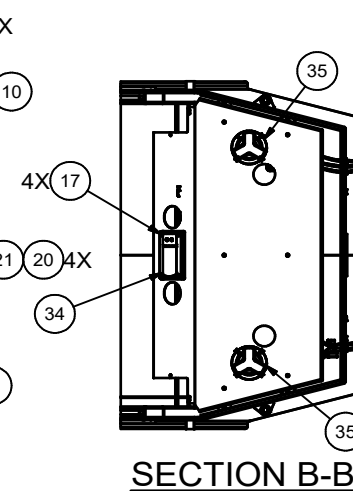

SECTION B-B