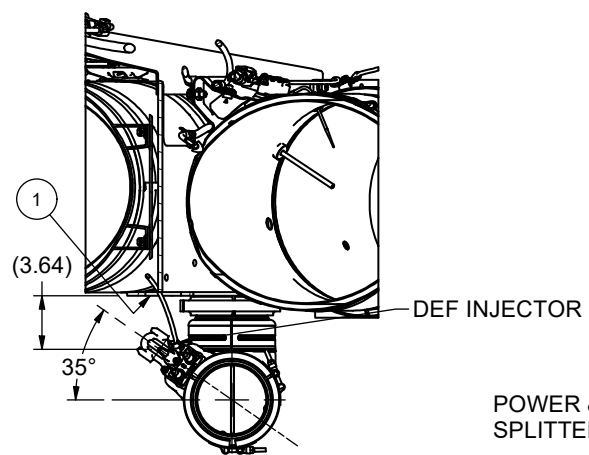
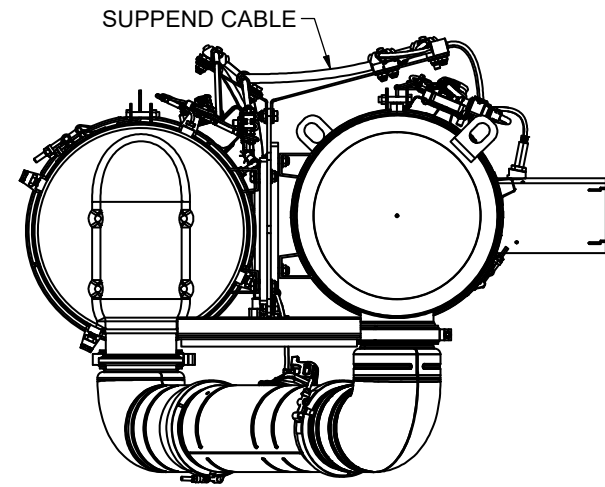
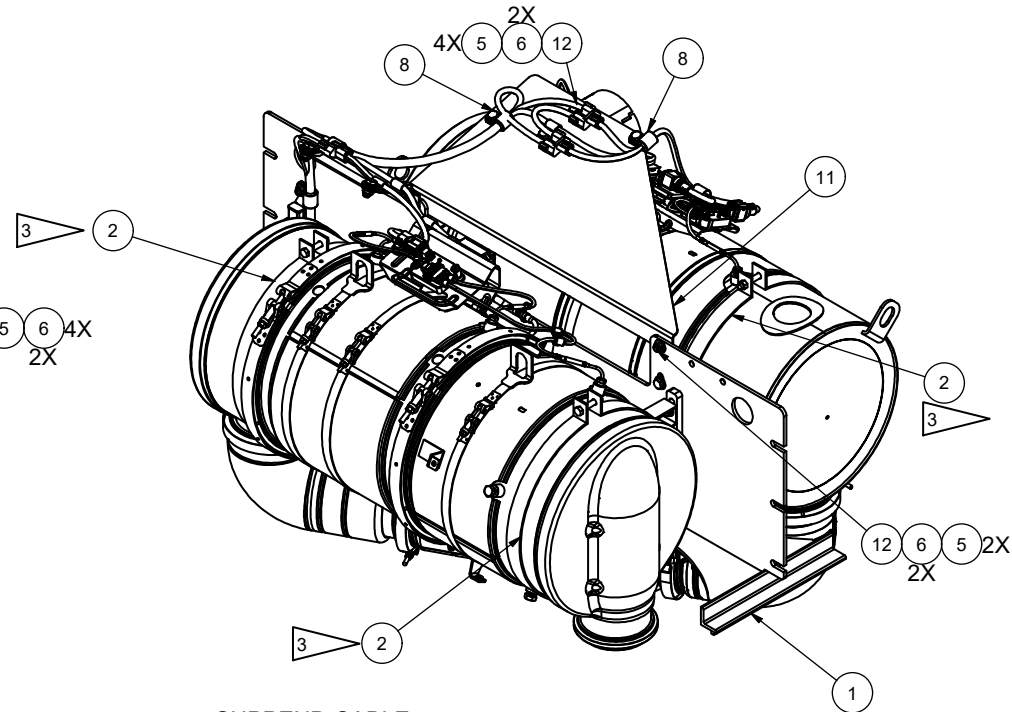
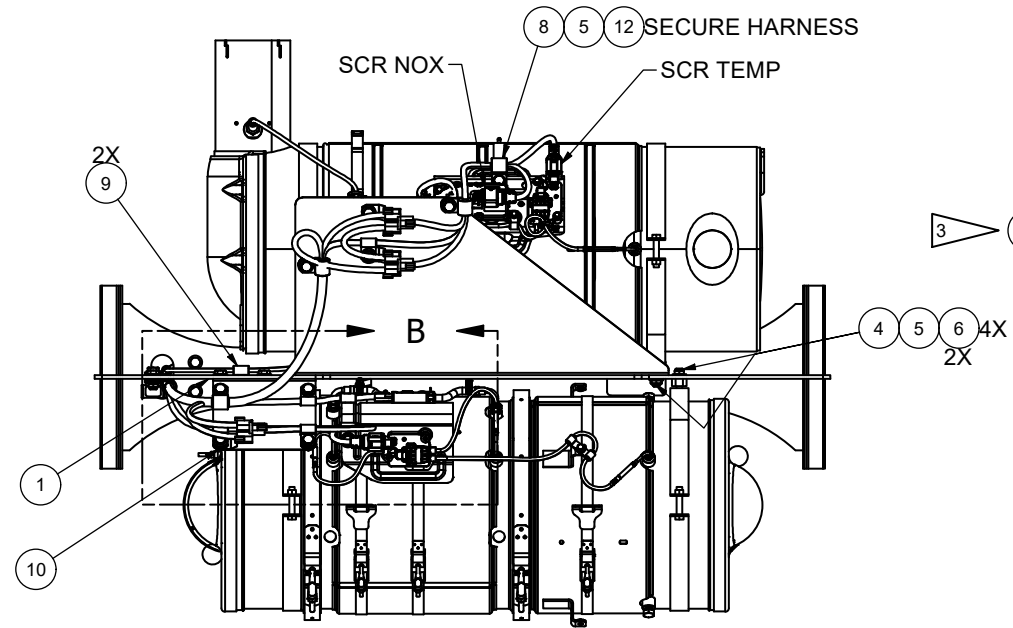

Aftertreatment Sub-Assembly

Aftertreatment Sub-Assembly

Item	Part No.	Qty	Description	Item	Part No.	Qty	Description
	599385		Aftertreatment Sub-Assembly				
1	599386	1	. Aftertreatment Mount	8	R13808098	6	. Clip, Insulated
2	92828	4	. Round Band Clamp (SS)	9	R13807640	8	. Clip, Insulated
4	R13801834	8	. Capscrew	10	599828	1	. Bracket
5	R13805167	25	. Locknut	11	599829	1	. Bracket
6	R13811432	53	. Washer	12	221532W	20	. Capscrew
7	599843	1	. Harness, Aftertreatment				

NOTES:

- 1 AFTERTREATMENT COMPONENTS ARE SHIPPED LOOSE WITH THE ENGINE. REFERENCE DWG 596989 FOR INFORMATION.
- 2 TORQUE CLAMPS TO 13.5 +/- 1.5 Nm. (AEB 24.75)
- 3 SECURE BAND CLAMP (ITEM 2) TO BOTH DPF/DOC AND SCR BY HAND TIGHTENING CLAMP HARDWARE TILL THE CLAMP IS SNUG TO AFTERTREATMENT DEVICES. ONCE SNUG, COMPLETE 1/2 TURN OF HARDWARE. SHELL DEFORMATION OF THE AFTERTREATMENT COMPONENTS TO NOT EXCEED 1mm (.04 INCHES) PER AEB 24.75.
- 4 ROTATE OUTLET OF DPF 180° SO THAT IT IS PARALLEL WITH INLET.



**SECTION A-A
VIEW ROTATED FOR CLARITY
DRT ORIENTATION**

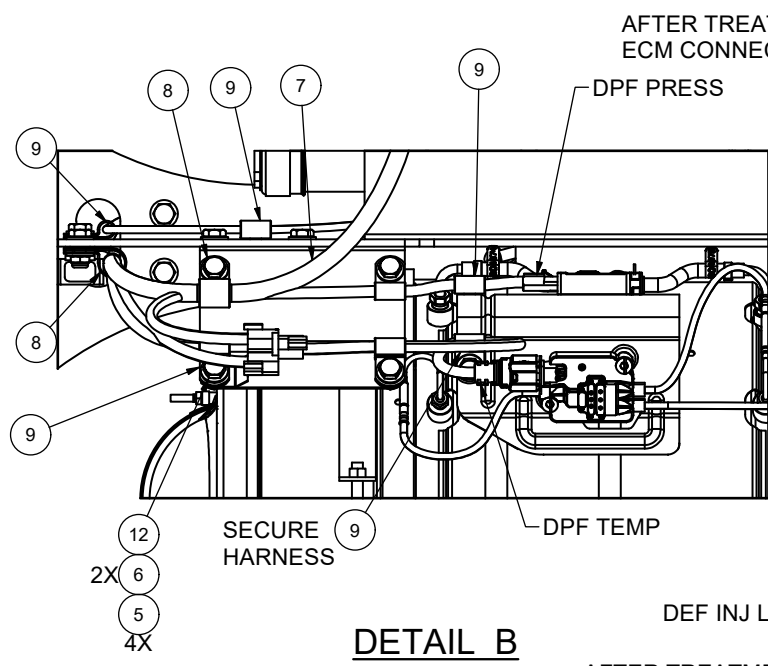
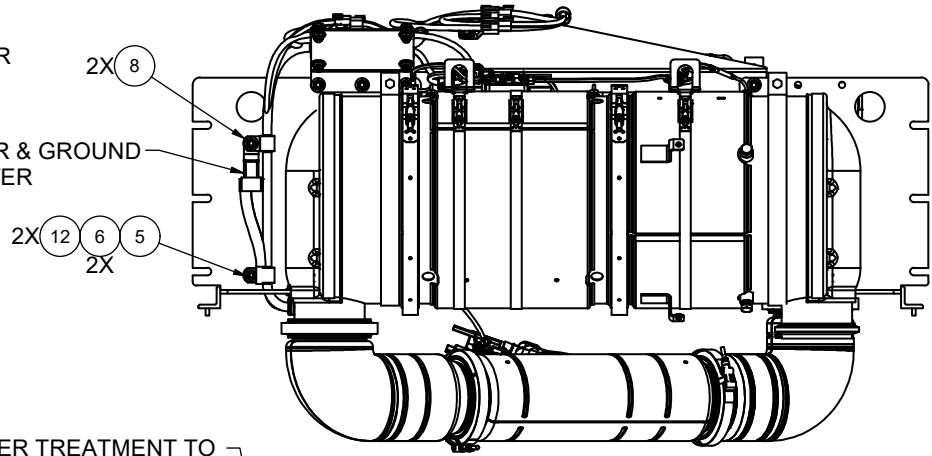

DETAIL B

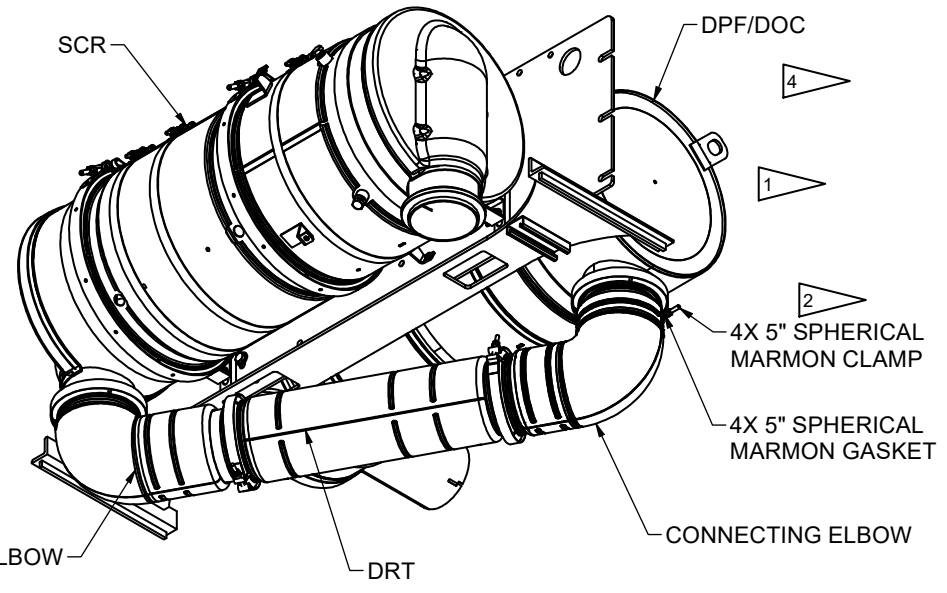
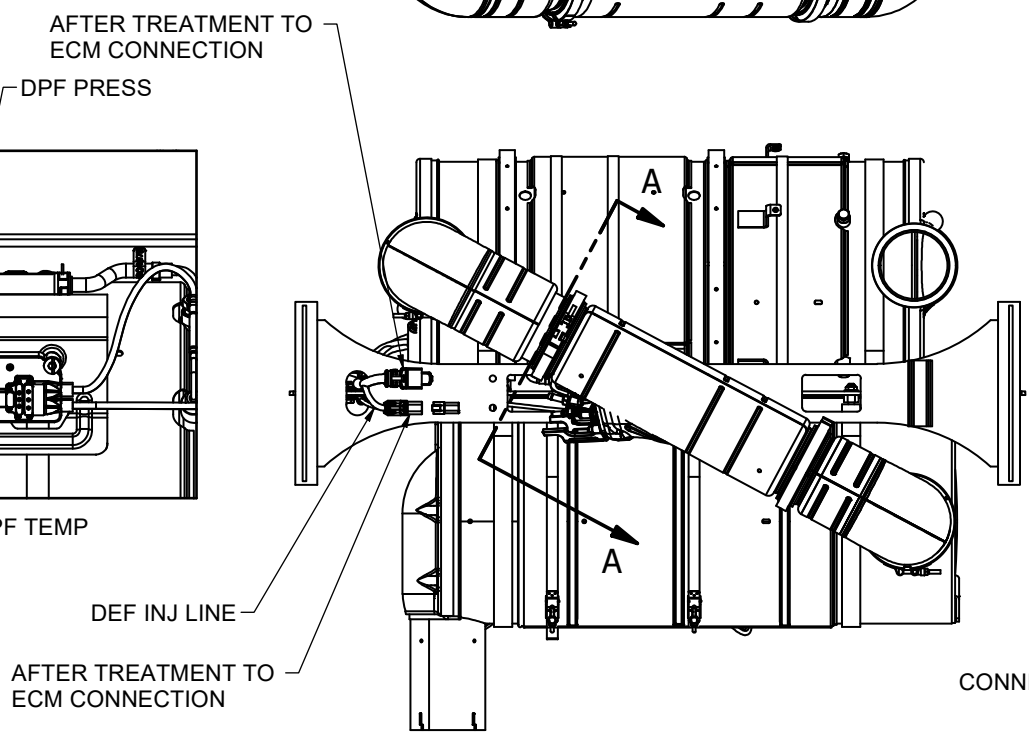

CONNECTING ELBOW