

Seat Installation

Seat Installation

Item	Part No.	Qty	Description	Item	Part No.	Qty	Description
	598942		Seat Installation				
1.1	* 598410	1	. Seat Assembly	1.34	589094	2	. Shim, 0.188
1.2	598424	1	. Platform	1.35	230838	2	. Connector, Cord
1.3	598258	1	. Cover Plate	1.36	230764	2	. Ring Nut
1.4	579412	1	. Angle	1.37	* 246923	1	. Throttle Assembly
1.5	00103341	37	. Washer	1.38	591654	1LB	. Grease
1.6	577272	1	. Plate, Pedal	1.40	* 598943	1	. Assembly, Steering Column
1.7	221771W	6	. Washer	1.41	599421	1	. Steering Column
1.8	223654	14	. Locknut	1.42	598427	3	. Plate, Column Side
1.9	Y25G-0408	6	. Capscrew	1.47	208264	2	. Grommet
1.10	Y17C-0616	6	. Capscrew	1.48	599909	19	. Machine Screw
1.11	Y17C-0624	1	. Capscrew	1.56	221499W	15	. Capscrew
1.12	R13801813	2	. Capscrew	1.59	596491	16	. Machine Screw
1.13	R13811043	1	. Capscrew	1.60	596258	1	. Cup Holder
1.14	586722	1	. Plate, Mounting	1.61	599853	1	. Wagner Smart Screen
1.15	200247	4	. Terminal Ring	1.62	600507	1	. Bracket, Monitor Mount
1.16	228351	10	. Terminal Ring	1.63	296148W	4	. Capscrew
1.17	221179	2	. Terminal Ring	1.64	WCT0000187	4	. Washer
1.18	22635	2	. Diode, 1A, 400V	1.65	600508	1	. Plate, Monitor Mount
1.19	243304	2	. Bearing Cup	1.66	00103339	10	. Washer
1.20	243305	2	. Bearing Cone	1.67	221703W	5	. Hex Nut
1.21	240151	2	. O-Ring	1.68	239083	1	. Grommet
1.22	576444	1	. Tube	1.82	586762	1	. Hose Tamer
1.23	576445	1	. Retainer	1.90	R10547	1	. Buzzer
1.24	Y09G-0820	6	. Capscrew	1.91	R13811032	4	. Capscrew
1.25	240566	2	. Relay	1.92	200454W	6	. Capscrew
1.26	240519	1	. Thermistor	1.93	R13812212	8	. Washer
1.27	574208	1	. Bracket	1.94	R13803445	4	. Locknut
1.28	574276	1	. Actuator	1.95	599703	1	. Switch, Ignition W/ Keys
1.29	574409	1	. Plate, Mounting	1.96	546943	1	. Decal, Ignition Switch
1.30	598433	1	. Bulkhead	1.98	599454	1	. Steering Cover
1.31	219436	10'	. Wire, #16 Black	1.99	R13810990	7	. Capscrew
1.32	231707	2'	. Wire, #16 Orange	1.100	221763W	13	. Washer
1.33	588904	1	. Shim, 0.060	1.101	* 590704	1	. Valve, Hydraulic Brake

* See Separate Coverage

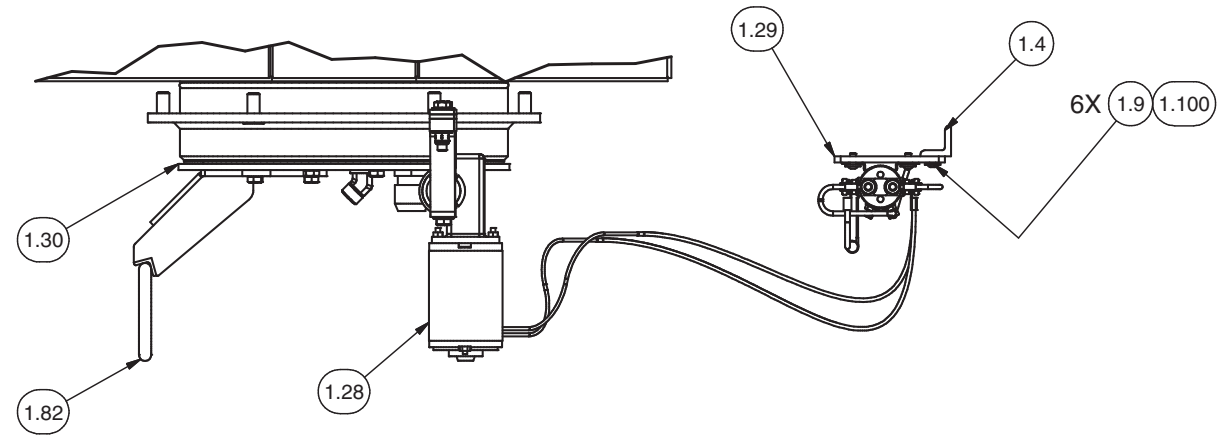

DETAIL 3B3

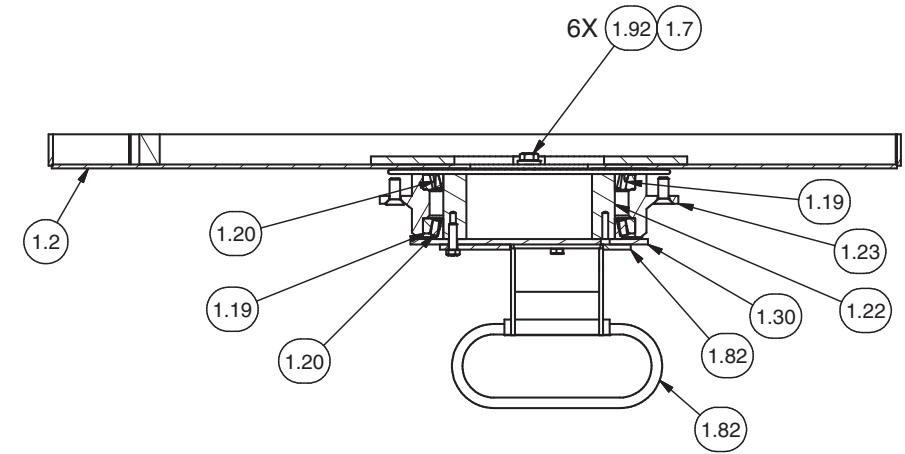

SECTION 3C3-3C3

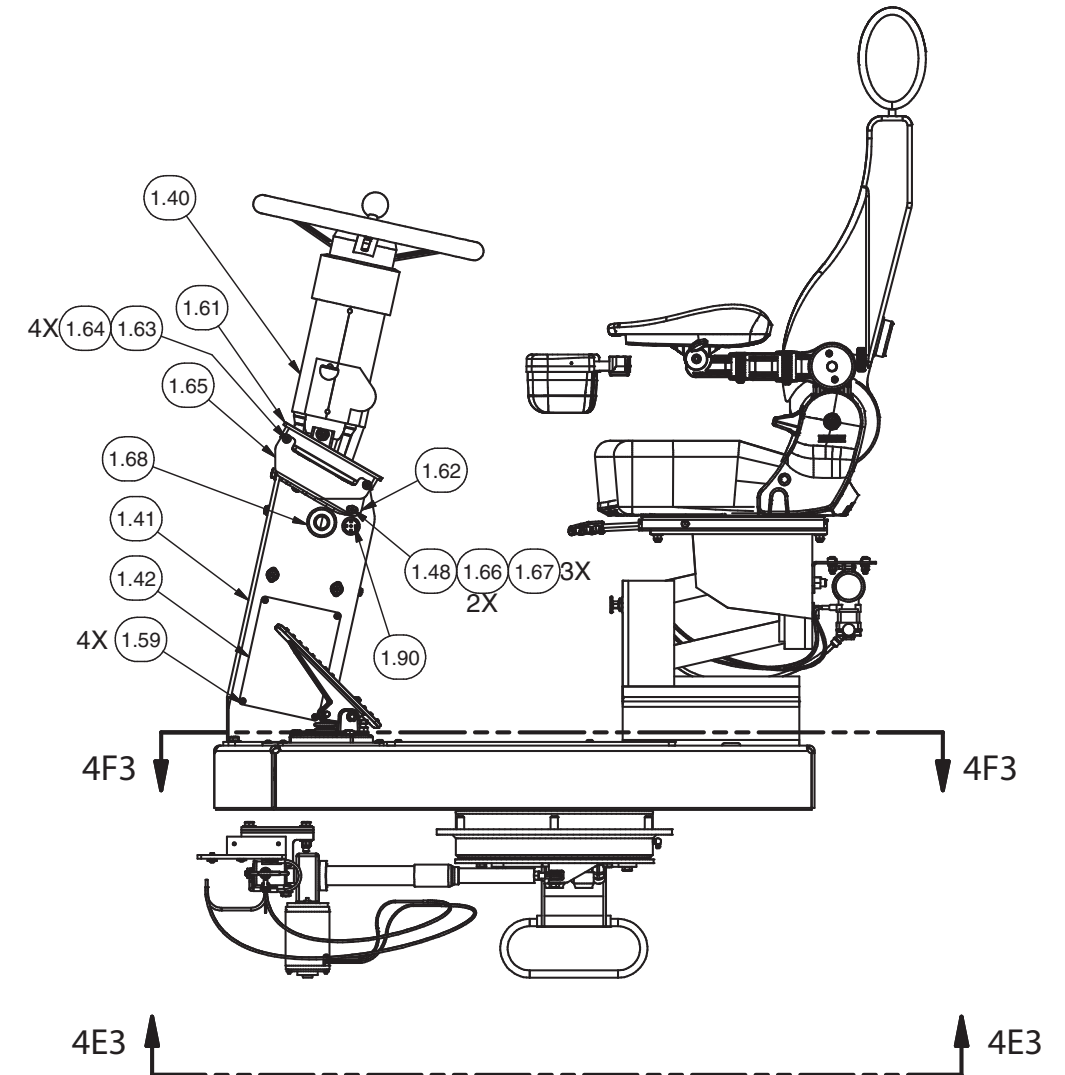
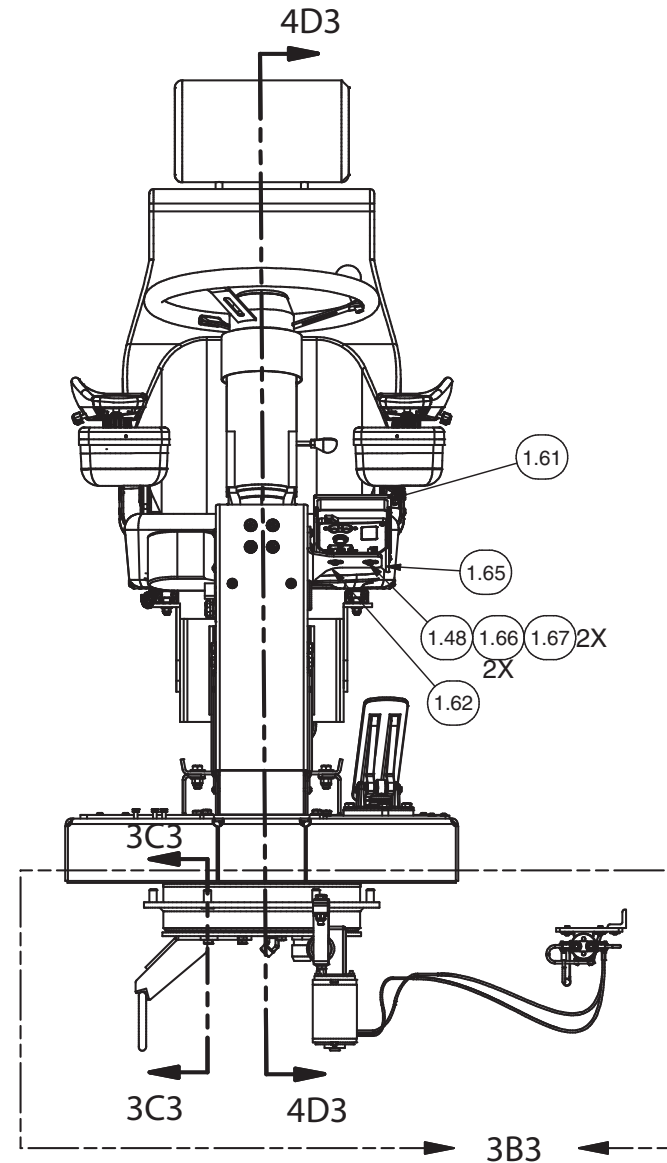
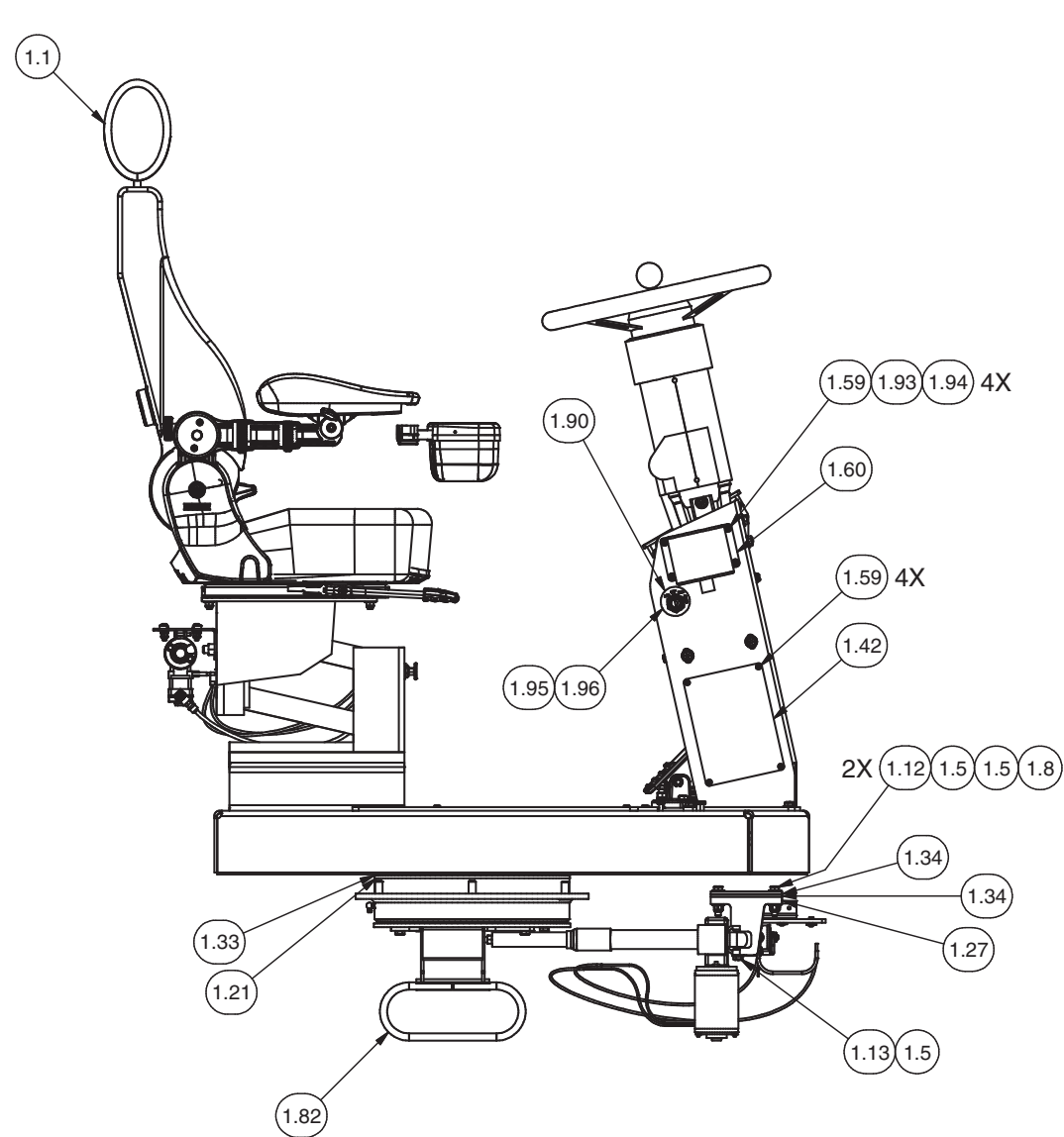

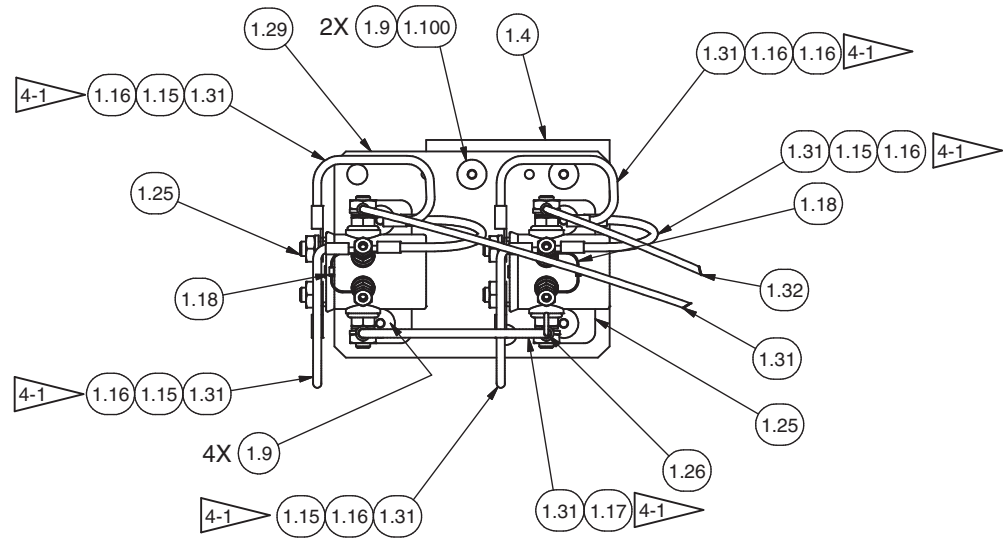

DETAIL 4G4
SEAT ROTATE RELAYS
FOLLOW WIRING SCHEMATIC FOR CONNECTIONS

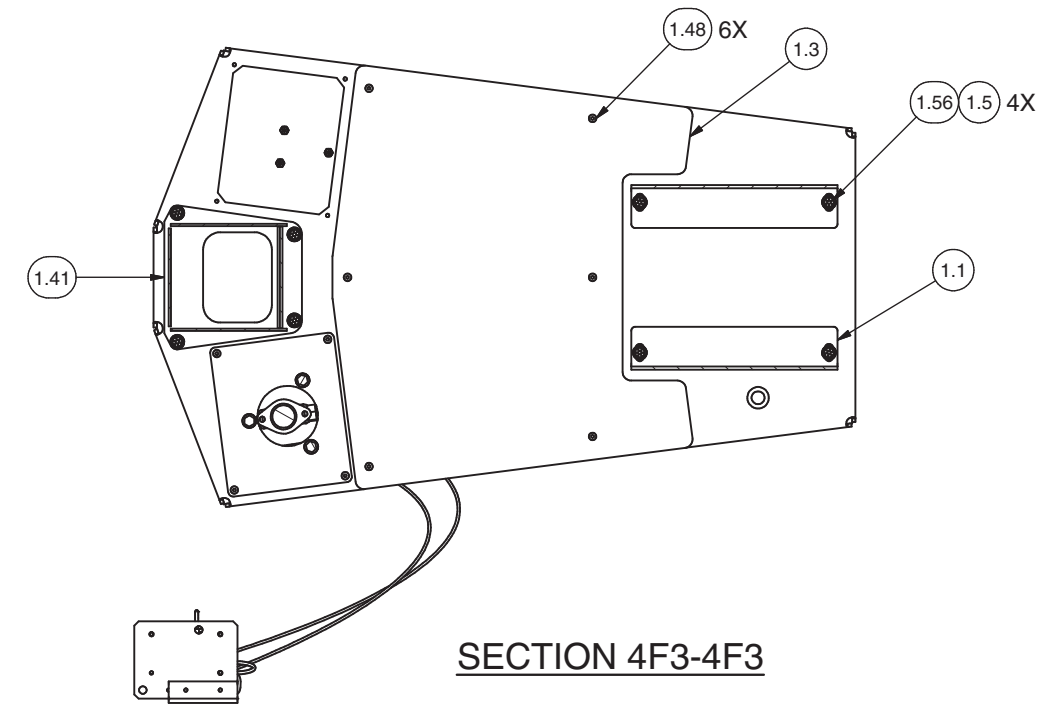

SECTION 4F3-4F3

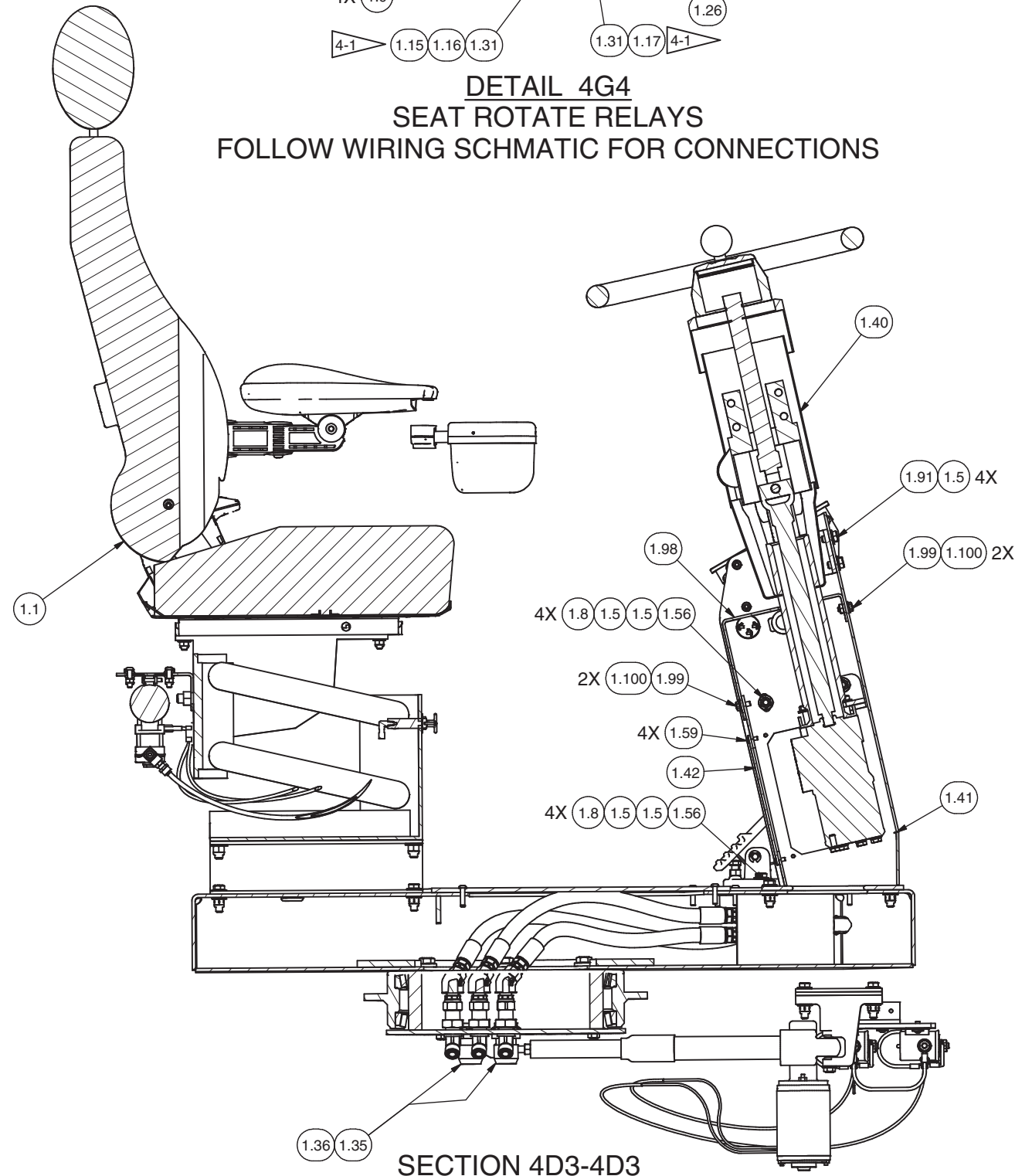

SECTION 4D3-4D3

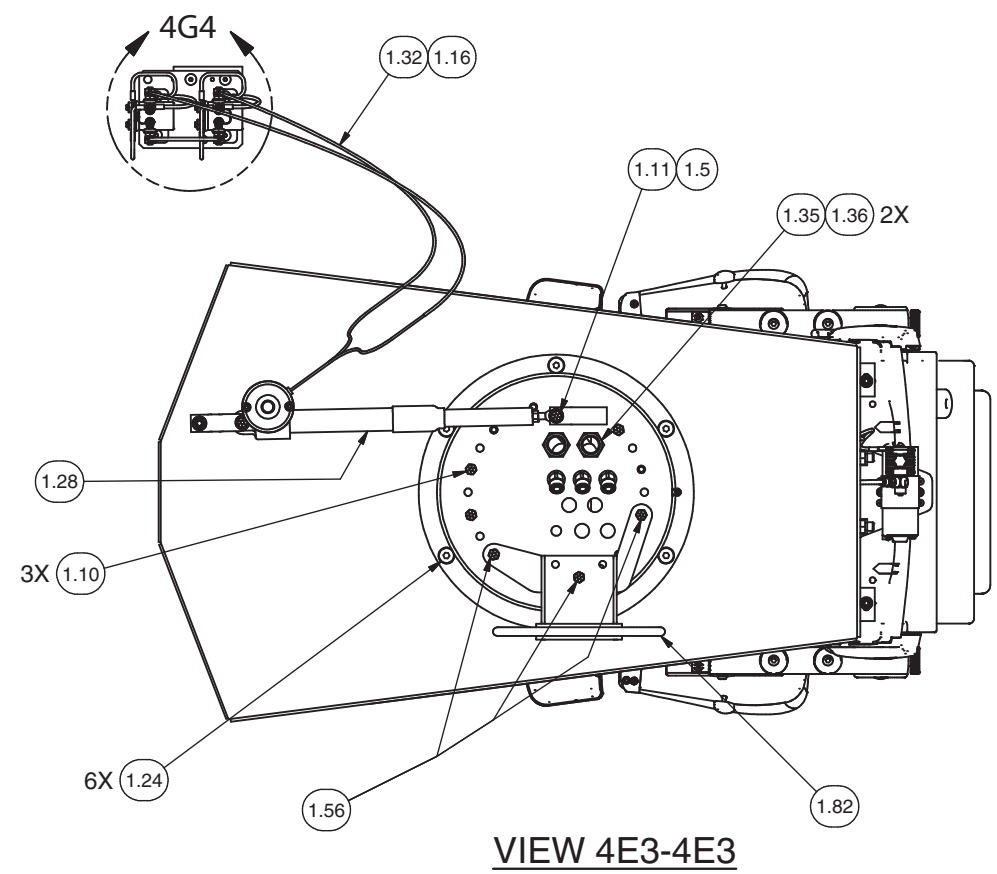

VIEW 4E3-4E3

- NOTES:
- 4-1 INSTALL LOOM ON ALL SEAT ROTATE WIRES.
 - 4-2 INSTALL SPACER PLATE AS REQUIRED

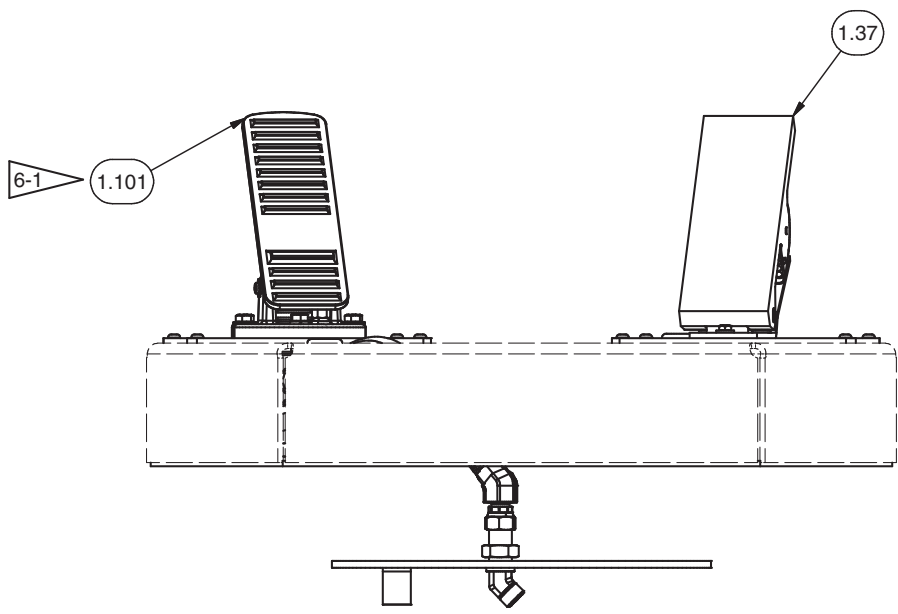
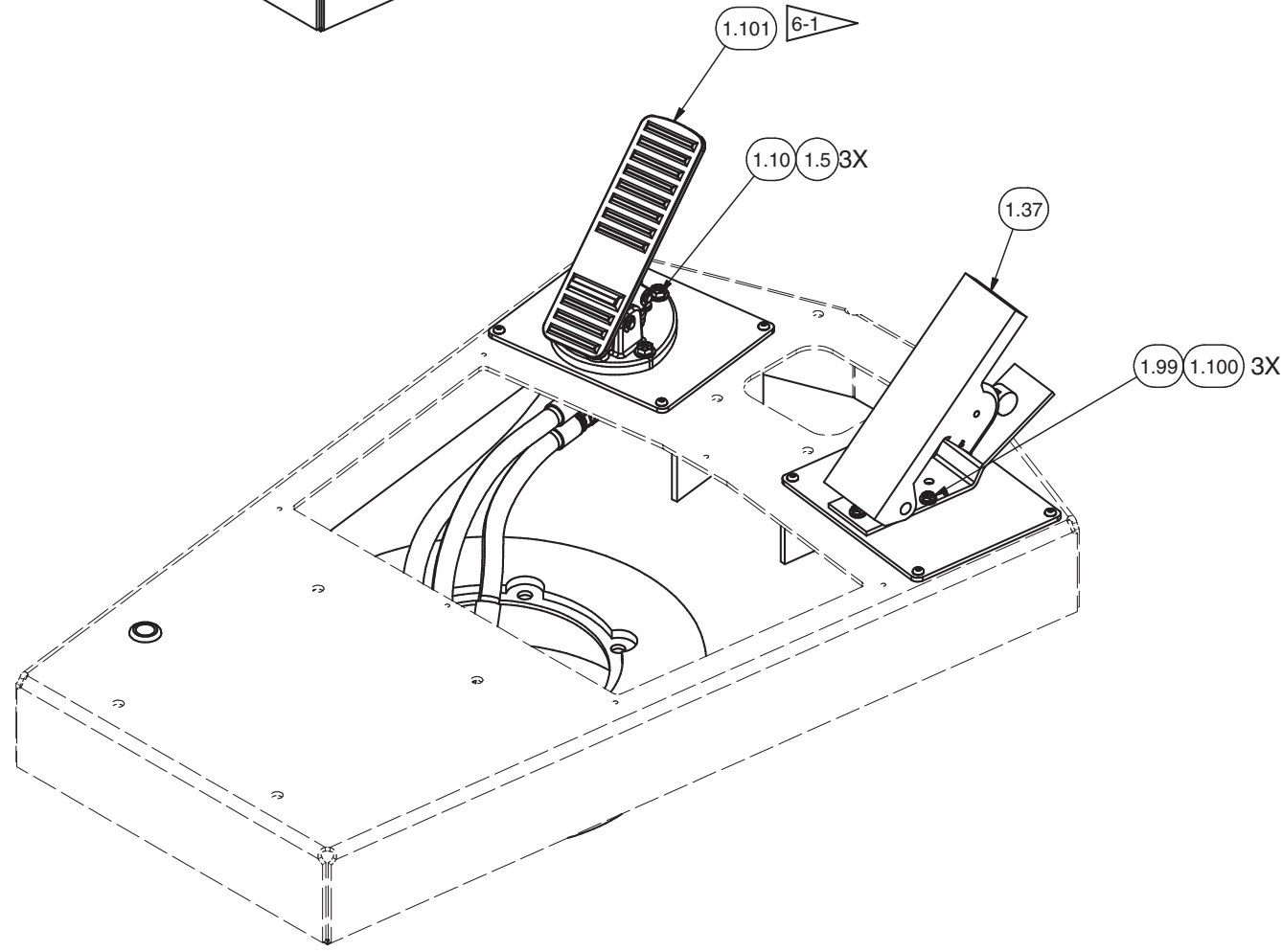
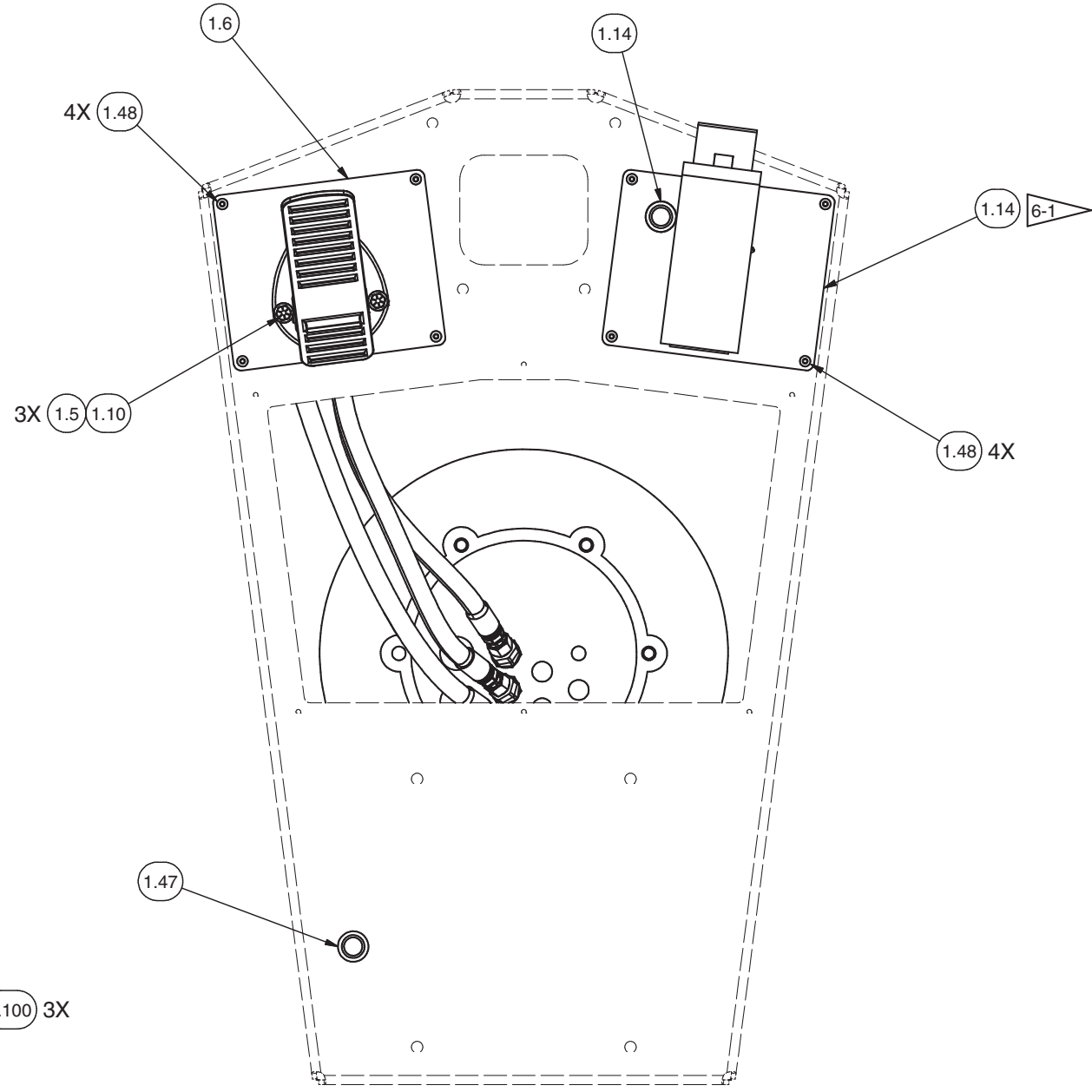
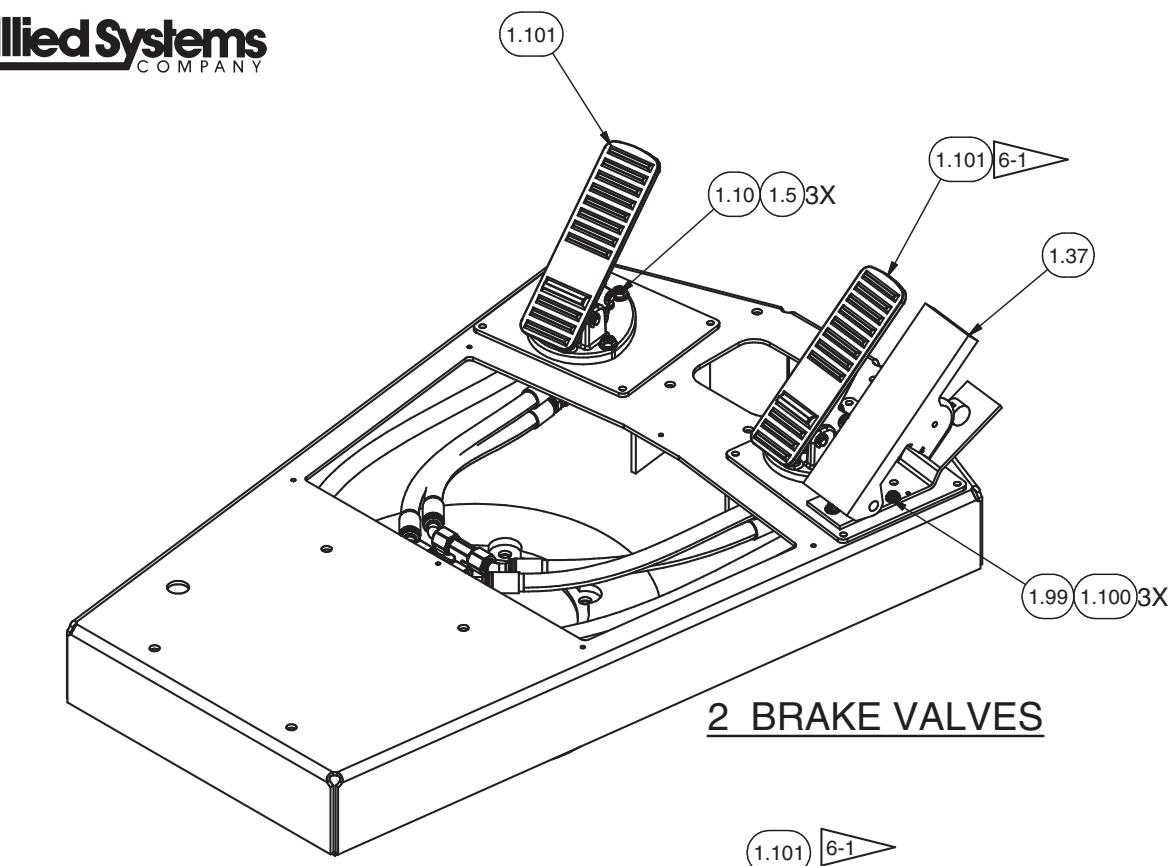

NOTES:

- 6-1 UNITS WITH (2) BRAKE VALVES (ITEM 1.101), THE SECOND BRAKE VALVE IS MOUNTED ON ITEM 1.14.
- THIS INCLUDES: (1) BRAKE VALVE ITEM 1.101
- (3) CAPSCREWS ITEM 1.5
- (3) WASHERS ITEM 1.10