

Electrical System - Carriage

Electrical System - Carriage

| Item | Part No. | Qty | Description | Item | Part No. | Qty | Description |
|------|---------------|-----|-------------------------------------|------|-----------|-----|---------------|
| | 598888 | | Electrical System - Carriage | | | | |
| 3.1 | 254837 | 1 | . Module, Expansion | 3.4 | R13811617 | 2 | . Capscrew |
| 3.2 | 598873 | 1 | . Wire Harness, Carriage XA2 | 3.5 | 595326 | 12 | . Mount, Tack |
| 3.3 | 296417W | 2 | . Washer | 3.6 | 249329 | A/R | . Cable Tie |

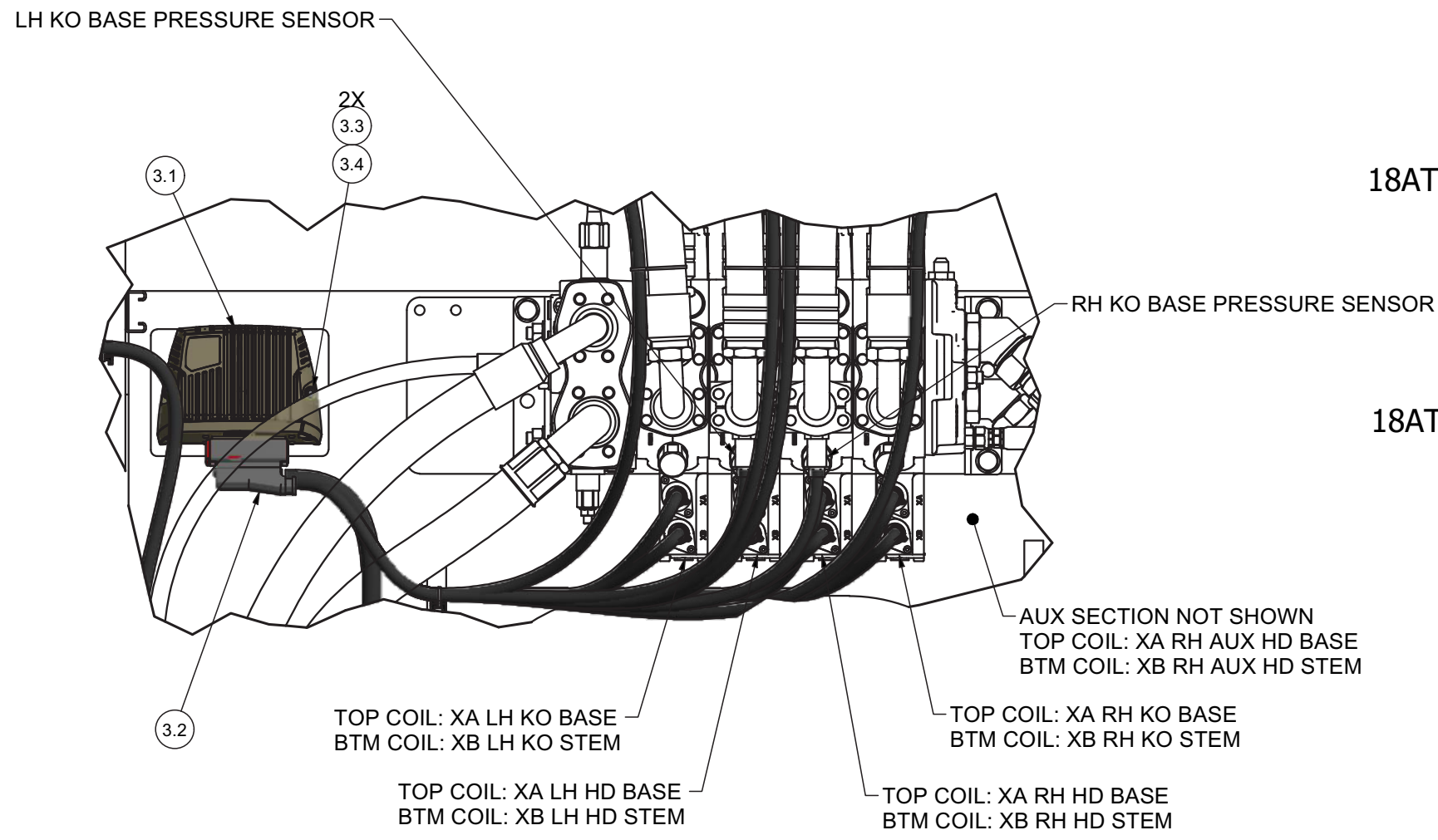
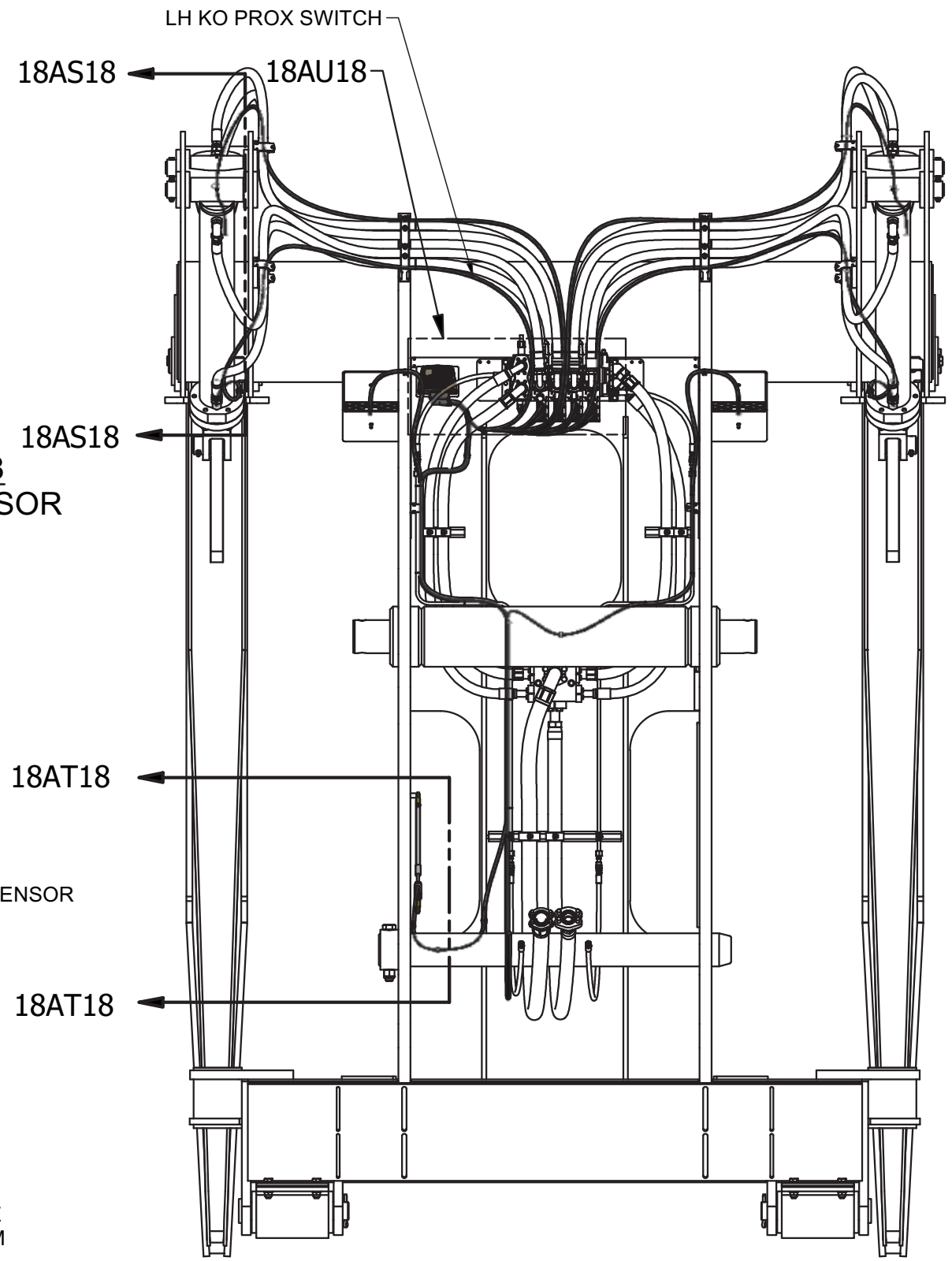
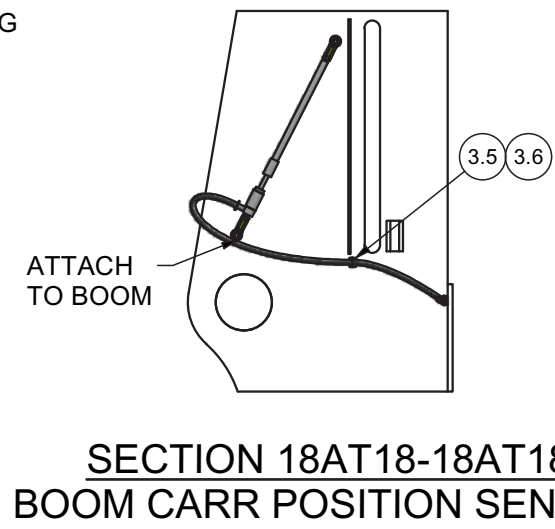
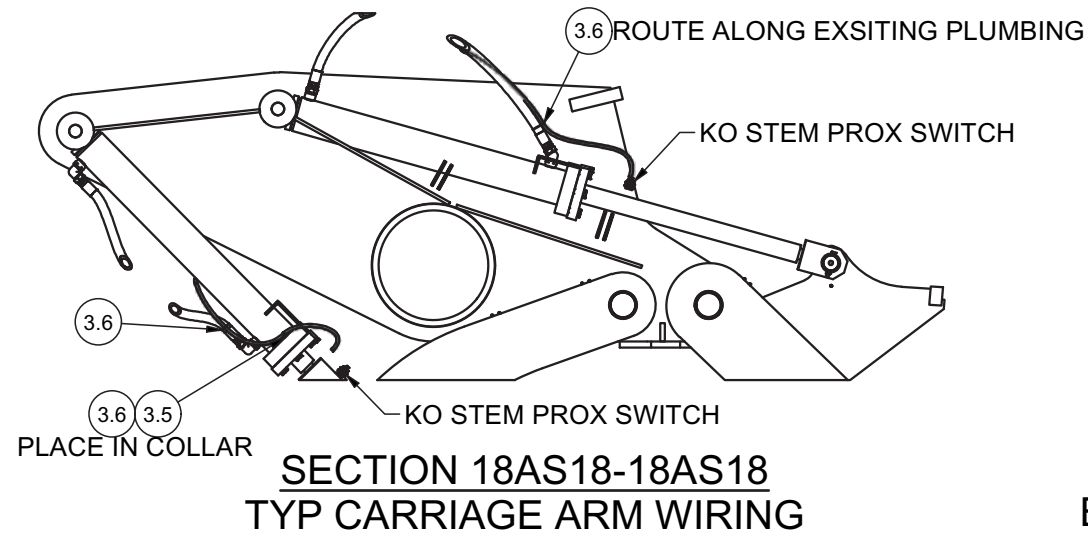

DETAIL 18AU18
CARRIAGE HEAD WIRING
SOME PARTS REMOVED FOR CLARITY