

Hydraulic System - Chassis

Hydraulic System - Chassis

Item	Part No.	Qty	Description	Item	Part No.	Qty	Description
	597041		Hydraulic System - Chassis				
1	586608	2	. Fitting	73	Y17C-0616	2	. Capscrew
2	224683	2	. Fitting	74	221767W	2	. Washer
3	203523	2	. O-Ring	75	237567	2	. Nut, Esna
4	253098	2	. Ball Valve	76	237508	4	. Clamp
5	218815	1	. Fitting	77	SMS0000217	6	. Screw, Self Tapping
6	203519	1	. O-Ring	78	221563W	8	. Capscrew
7	209078	1	. Fitting	82	216042	8	. T-Bolt Clamp
8	258875	1	. Fitting	83	11740	17	. Kit, Split Flange
9	209139	2	. Fitting		203446	1	. O-Ring
10	227949	1	. Fitting	88	221763W	6	. Washer
11	231585	8	. Capscrew	89	258609	1	. Fitting
12	561316	1	. Fuel Filter Bracket	90	586342	1	. Pipe, Return
13	253983	1	. Ball Valve	91	15383	4	. Kit, Split Flange
14	221771W	16	. Washer	97	231537	2	. Clamp
15	253421	2	. Fitting	98	589310	1	. Screen, Wire
16	209159	1	. Fitting	99	257794	1	. Cap, Dust (Rubber)
17	209505	1	. Fitting	102	* 597277	1	. Assembly, Filter Manifold
18	224744	1	. Breather Assembly	109	200454W	4	. Capscrew
	230463	1	. Element	110	585727	1	. Flange
19	211398	1	. Draincock	111	209715	1	. Fitting
20	* 243457	2	. Filter	112	235387	1	. Fitting
21	247342	1	. Diffuser, Flow	113	209323	1	. Fitting
22	R13801972	1	. Fitting	114	209536	6	. Clamp Half
23	586527	1	. Tube	115	203446	6	. O-Ring
24	586528	1	. Tube	116	R13811432	8	. Hard Washer
25	12721	3	. Kit, Split Flange	117	243421	4	. Capscrew
	203519	1	. O-Ring	118	210709	2	. Fitting
26	219321	4	. T-Bolt Clamp	119	* 589312	1	. Manifold Assembly
27	R13803393	4	. Fitting	120	R13806944	8	. Capscrew
28	214219	2	. Fitting	121	597564	0	. Weldment
29	209133	4	. Fitting	122	221569W	0	. Capscrew
30	CLP0100112	6	. Clamp, Hydra-Zorb	123	231248	0	. Clamp
31	209490	2	. Fitting	150	597078	1	. Kit, Hose
32	13987	1	. Fitting	150.1	589583	2	. Hose Assembly
33	245414	1	. Fitting	150.2	259163	1	. Hose Assembly
34	219599	2	. Fitting	150.3	241230	2	. Hose Assembly
35	258931	1	. Fitting	150.4	597561	1	. Hose Assembly
36	209511	8	. Fitting	150.5	589591	1	. Hose Assembly
37	258868	1	. Fitting,	150.6	258951-20	1	. Suction Hose
38	223362	1	. Fitting	150.7	589585	2	. Hose Assembly
39	209619	1	. Fitting	150.8	589586	1	. Hose Assembly
40	232332	1	. Fitting	150.9	259164	1	. Hose Assembly
41	R525293	2	. Magnet, Ceramic	150.10	231318	1	. Hose Assembly
42	255555	1	. Ball Valve	150.11	243154	1	. Hose Assembly
43	231415	2	. Glass, Sight Level	150.12	589587	1	. Hose Assembly
45	588685	2	. Stand	150.13	234838	2	. Hose Assembly
46	* 258525	1	. Oil Cooler	150.14	259165	4	. Hose Assembly
47	R13811082	4	. Capscrew	150.15	R12121	1	. Hose Assembly
48	217442	1	. Fitting	150.16	201440-90	2	. Suction Hose
49	209799	1	. Fitting	150.17	590084	1	. Hose Assembly
50	209486	1	. Fitting	150.18	259219	1	. Hose Assembly
51	209215	1	. Fitting	150.19	596597	1	. Hose Assembly
62	223784	1	. Fitting	150.20	597027	1	. Hose Assembly
63	209714	1	. Fitting	150.21	589589	1	. Hose Assembly
68	240395	1	. Coupler, Male	150.22	597028	1	. Hose Assembly
69	231251	2	. Clamp, Hydra-Zorb	150.23	255526	1	. Hose Assembly
70	588754	1	. Tube Assembly	150.24	589590	1	. Hose Assembly
71	588755	1	. Tube Assembly	150.26	589523	1	. Hose Assembly
72	597092	1	. Clamp	150.27	593546	1	. Hose Assembly

* See Separate Coverage

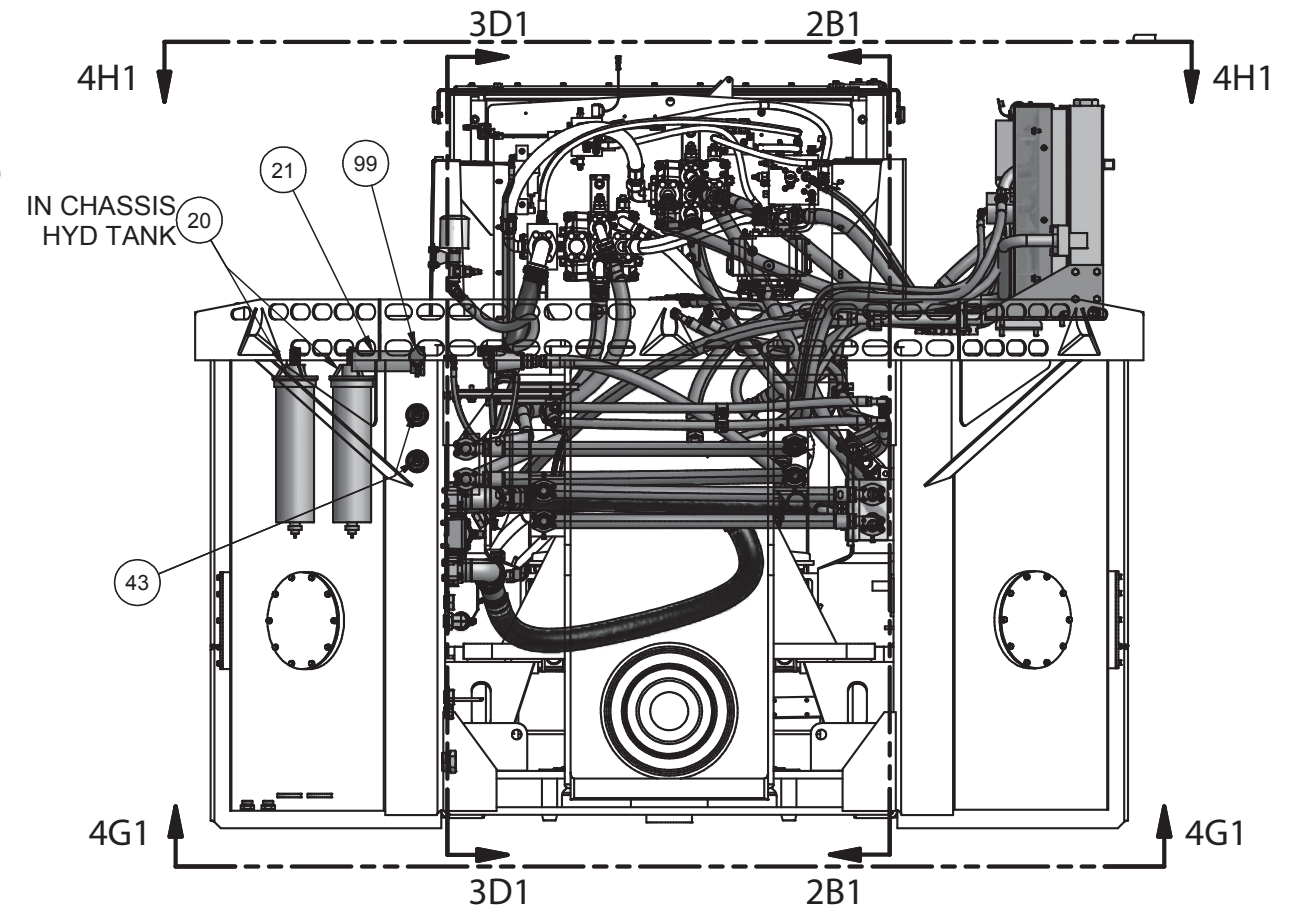
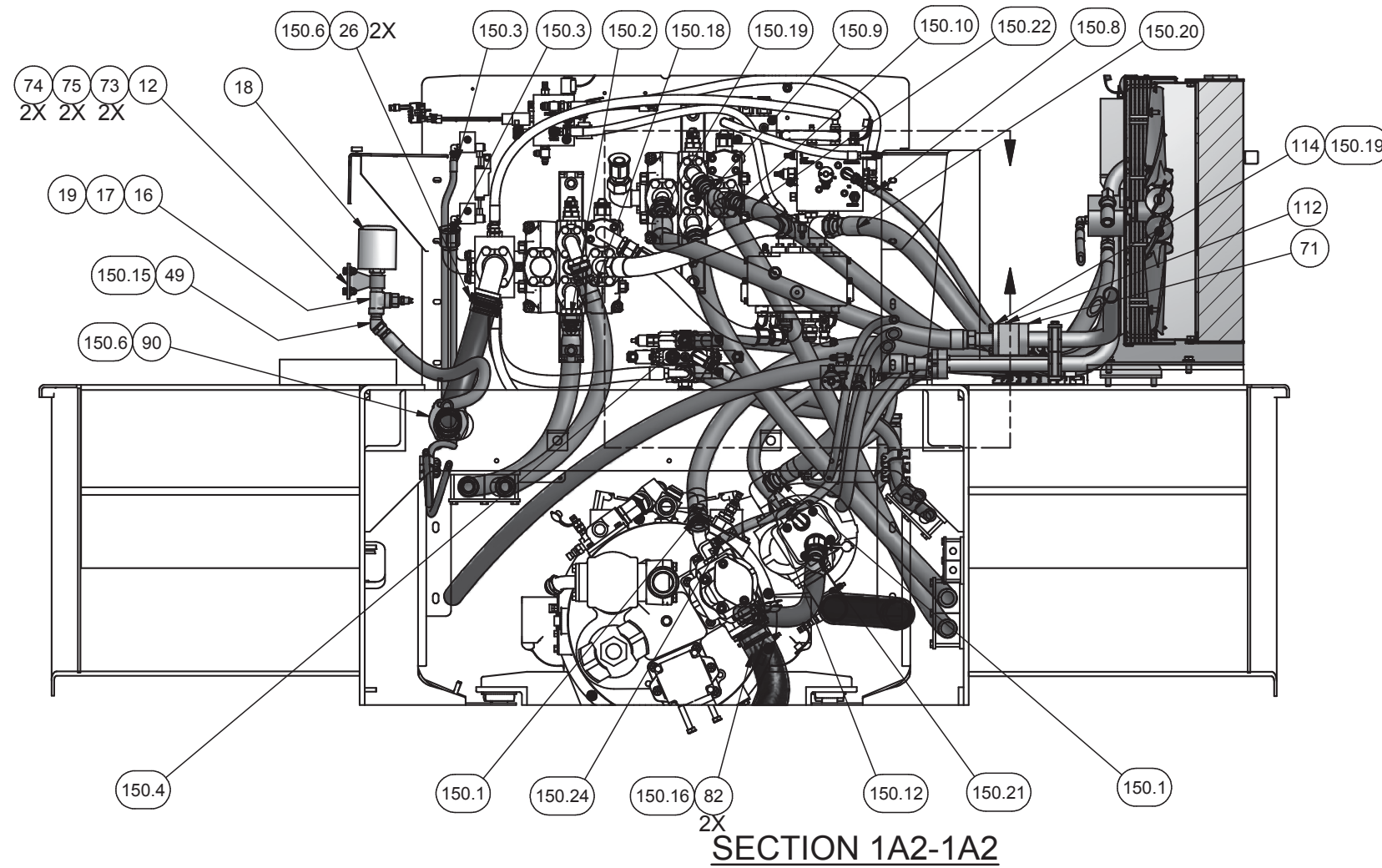

NOTES:

1: SOME VIEWS MAY HAVE HAD ITEMS REMOVED FOR CLARITY

2: HYDRAULIC OIL COOLER CIRCUIT: FAN MANIFOLD PORT A TO FAN MOTOR PORT INLET, MOTOR PORT OUTLET TO FAN MANIFOLD PORT B.

