

---

Assembly, Cab

## Assembly, Cab

Item	Part No.	Qty	Description	Item	Part No.	Qty	Description
	<b>597038</b>		<b>Assembly, Cab</b>				
1	* 597079	1	. Cab	31	* 597709	1	. Valve, Hydraulic Brake
2	* 252512	1	. Valve, Steering	33	* 597471	1	. Assembly, Horn/Park Brake
3	* 246923	1	. Throttle Assembly	38	Y73G-0620	4	. Capscrew
4	224222	4	. Vibration Dampener	39	296420W	3	. Hard Washer
5	* 597469	1	. Assembly, ECM	40	293629W	3	. Capscrew
11	* 597432	1	. Assembly, Electrical Panel	41	287816W	3	. Capscrew
13	* 597481	1	. Assembly, Remote Monitor	42	296417W	15	. Hard Washer
14	257786	1	. Base, Magnet	43	Y09C-M0616	8	. Capscrew
15	904334	1	. Pad, Base	45	557376	4	. Flat Washer
16	591002	1	. Bracket	46	597472	2	. Stud, Knob Threaded Metric
17	221560W	1	. Capscrew	47	302398W	8	. Locknut
18	R13811193	1	. Nut, Esna	48	296153W	8	. Capscrew
24	597100	2	. Weldment, Cab Mount	49	296416W	16	. Hard Washer
25	243626	4	. Capscrew	50	254837	2	. Module, Expansion
26	296426W	4	. Hard Washer	51	296418W	2	. Hard Washer
27	221657W	4	. Capscrew	52	296166W	2	. Capscrew
28	221777W	4	. Hard Washer	53	597710	1	. Cover
29	597249	2	. Channel	54	302399W	4	. Locknut
30	597421	1	. Blower, 24VDC	55	598860	1	. Cover Plate

\* See Separate Coverage

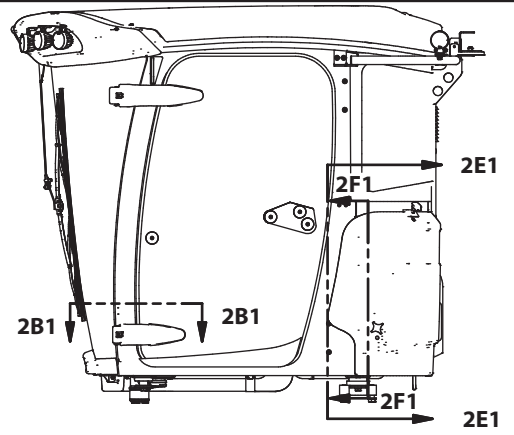
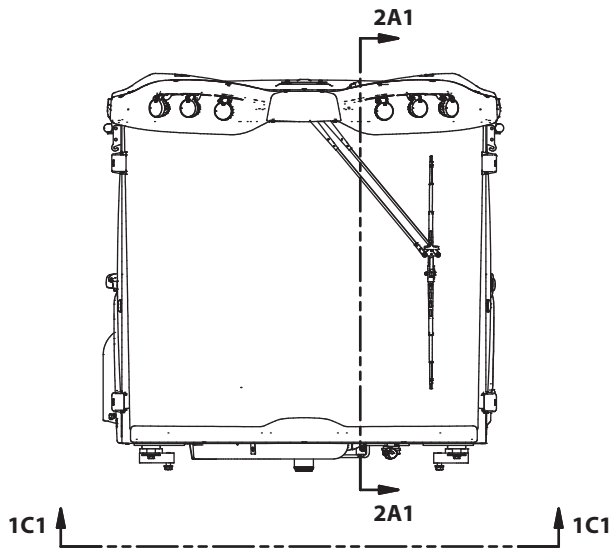

LOCATE ON  
ROPS ONCE  
INSTALLED

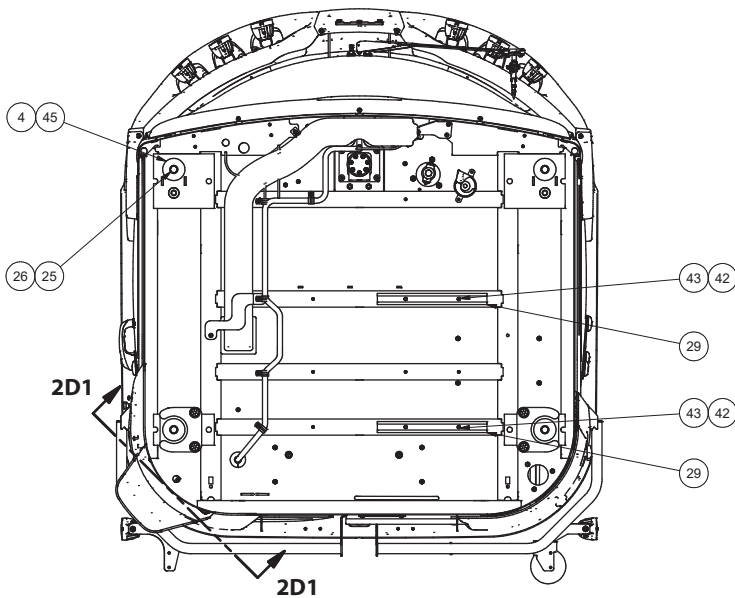
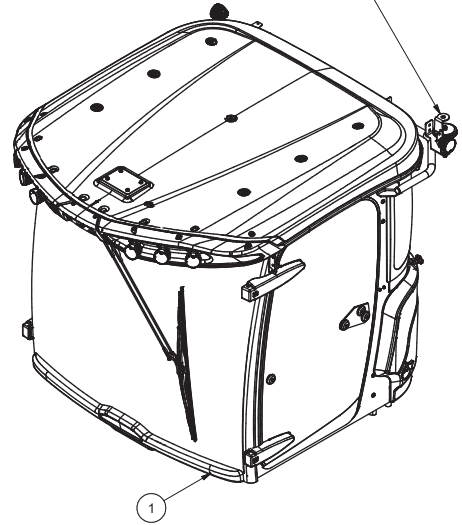

**VIEW 1C1-1C1**

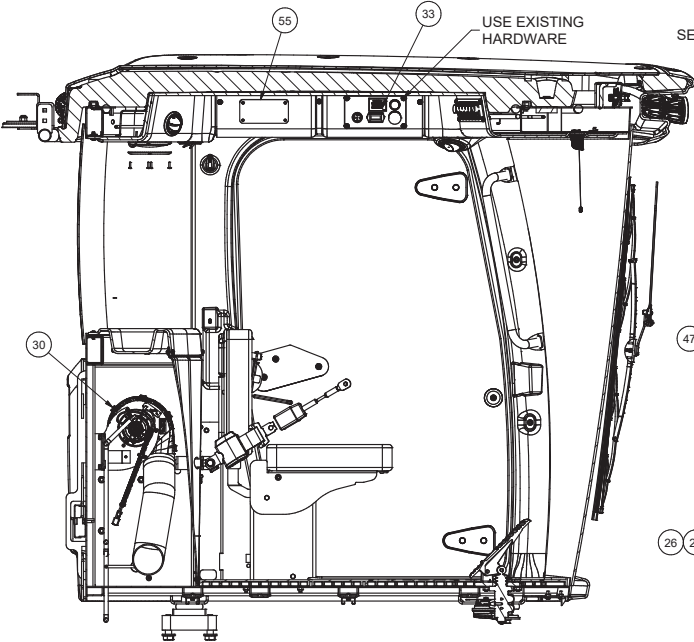

**SECTION 2A1-2A1**

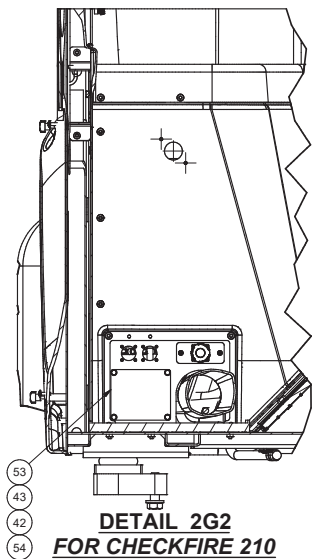

**DETAIL 2G2  
FOR CHECKFIRE 210**

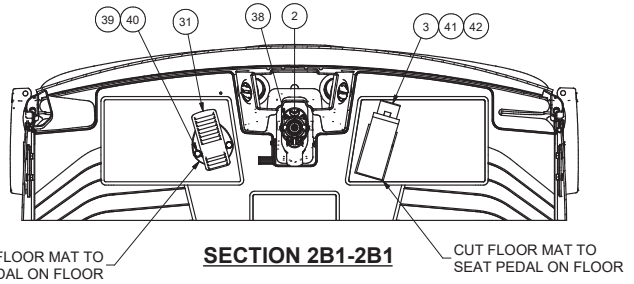

**SECTION 2B1-2B1**

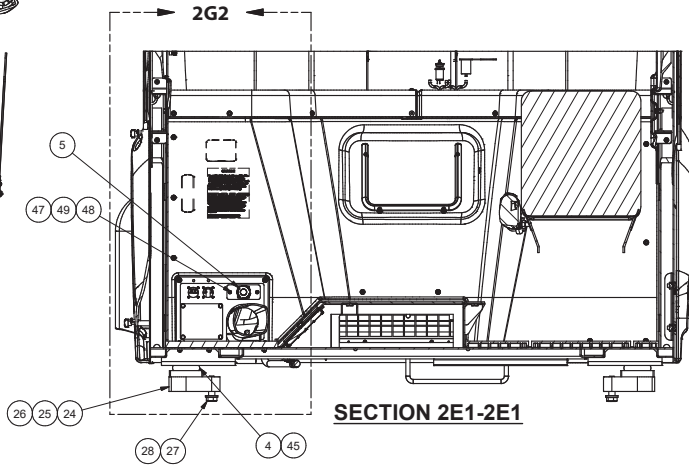

**SECTION 2E1-2E1**

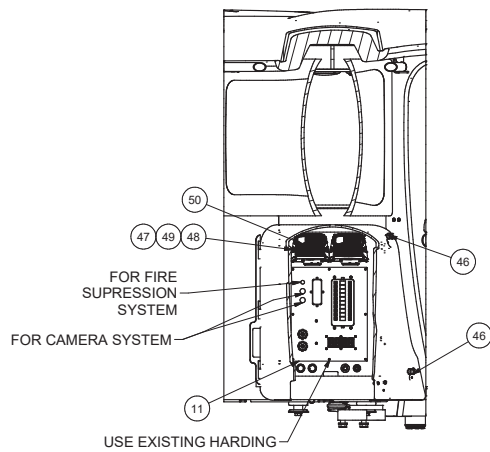

**SECTION 2D1-2D1  
VIEW ROTATED FOR CLAIRITY**

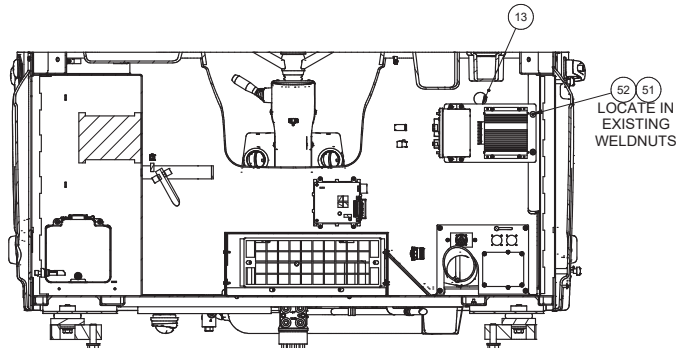

**SECTION 2F1-2F1**