

Console Assembly, Overhead

Console Assembly, Overhead

Item	Part No.	Qty	Description	Item	Part No.	Qty	Description
	594718		Console Overhead Assembly				
1.1	586468	1	. Console Weldment, Overhead	1.59	232237	41	. Terminal Block
1.2	* 589694	1	. Hinge Assembly	1.60	239317	69	. Terminal Block
1.3	* 589695	1	. Hinge Assembly	1.61	584934	1	. Din Rail
1.4	R13810996	4	. Capscrew	1.62	238891	3	. Relay
1.5	221763W	17	. Washer	1.63	22632	3	. Relay Socket
1.6	R13811189	6	. Locknut	1.64	232908	1	. Relay
1.7	GAG0001133	1	. Hourmeter	1.65	232909	1	. Relay Socket
1.8	234740	2	. Frame, Mounting	1.66	586963	13	. Plug,Pilot Light
1.13	236485	2	. Frame, Mounting	1.67	587108	1	. Resistor
1.14	237688	4	. Switch, 24V	1.70	247468	1	. End Plate
1.15	236486	1	. Symbol, Light Front	1.71	232238	3	. End Plate
1.16	234742	1	. Symbol, Rear Lamp	1.73	234737	8	. Housing, Socket
1.17	234741	2	. Symbol, Lamp	1.74	234738	8	. Housing, Socket
1.18	582110	1	. Decal	1.75	235217	54	. Connector, Female
1.19	* 593449	1	. Controller, A/C	1.76	Y09G-(0832)08	9	. Capscrew
1.22	22635	4	. Diode	1.77	R13812442	12	. Locknut
1.24	588431	3	. Led, Panel Mnt	1.78	Y09G-(1024)24	4	. Capscrew
1.27	249692	1	. Display Module, Powerview	1.79	R13809543	8	. Locknut
1.29	573235	1	. Cover	1.82	589110	1	. Console Weldment
1.30	234507	1	. Symbol, Fan	1.83	18720W	3	. Capscrew
1.31	234736	3	. Switch, 24V	1.84	232969	4	. Capscrew
	234508	1	. Socket	1.85	00103338	8	. Flat Washer
	236901	1	. Bulb	1.86	246945	5'	. Cable
1.33	234739	1	. Dimmer Switch	1.87	591378	2	. Fuse
1.34	248579	1	. Lens, Air Cleaner	1.88	590970	1	. Wire Harness
1.35	234509	9	. Cover, Blank	1.89	591430	1	. Wire Harness
1.37	R13656	1	. Switch, 24V	1.91	236504	1	. Lens, Green
1.38	593451	2	. Switch	1.92	591893	1	. Lens, Start
1.39	596411	1	. Controller - Rad/Cac Fan	1.94	591962	10	. Terminal, Female
1.40	247209	3	. Terminal Block	1.95	591970	3	. Connector Assembly, Female
1.41	232903	1	. Power Converter	1.96	232239	27	. Jumper
1.42	592582	1	. Din Rail	1.97	239214	1	. Jumper
1.44	586451	2	. Bar,Spacer	1.99	Y09G-(0832)16	3	. Capscrew
1.45	588433	2	. Led, Panel Mnt	1.100	231903	1	. Plug, Button
1.46	R10547	1	. Buzzer	1.104	256809	1	. Machine Screw
1.48	243476	1	. Cover, Dust	1.105	247673	1	. Nut, Nylock
1.50	238982	7	. Pin	1.106	593739	1	. Decals, Electrical
1.51	027-0465	4	. Machine Screw	1.107	586806	2	. Bar,Spacer
1.52	241761	6	. End Stop	1.108	R13801782	4	. Capscrew
1.57	242949	2	. Terminal, Fuse				
1.58	242950	2	. Fuse				

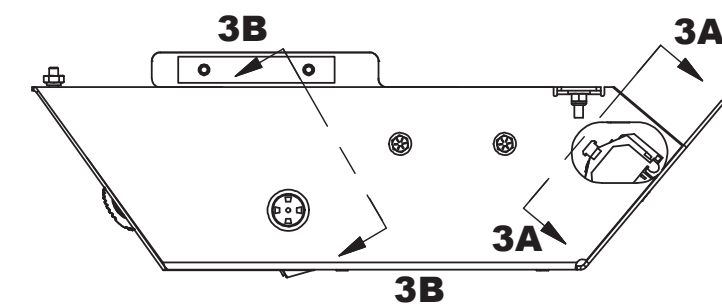
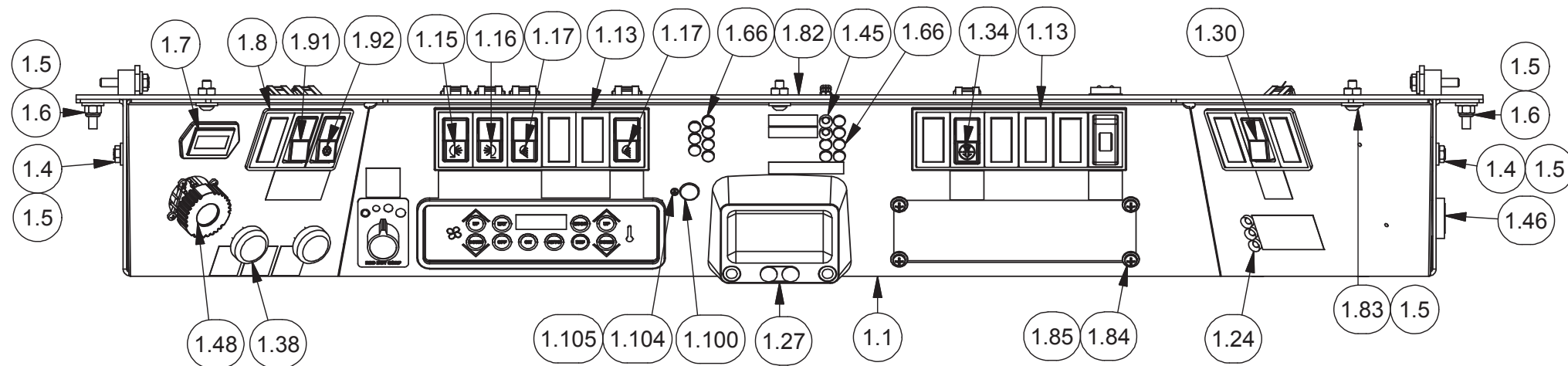
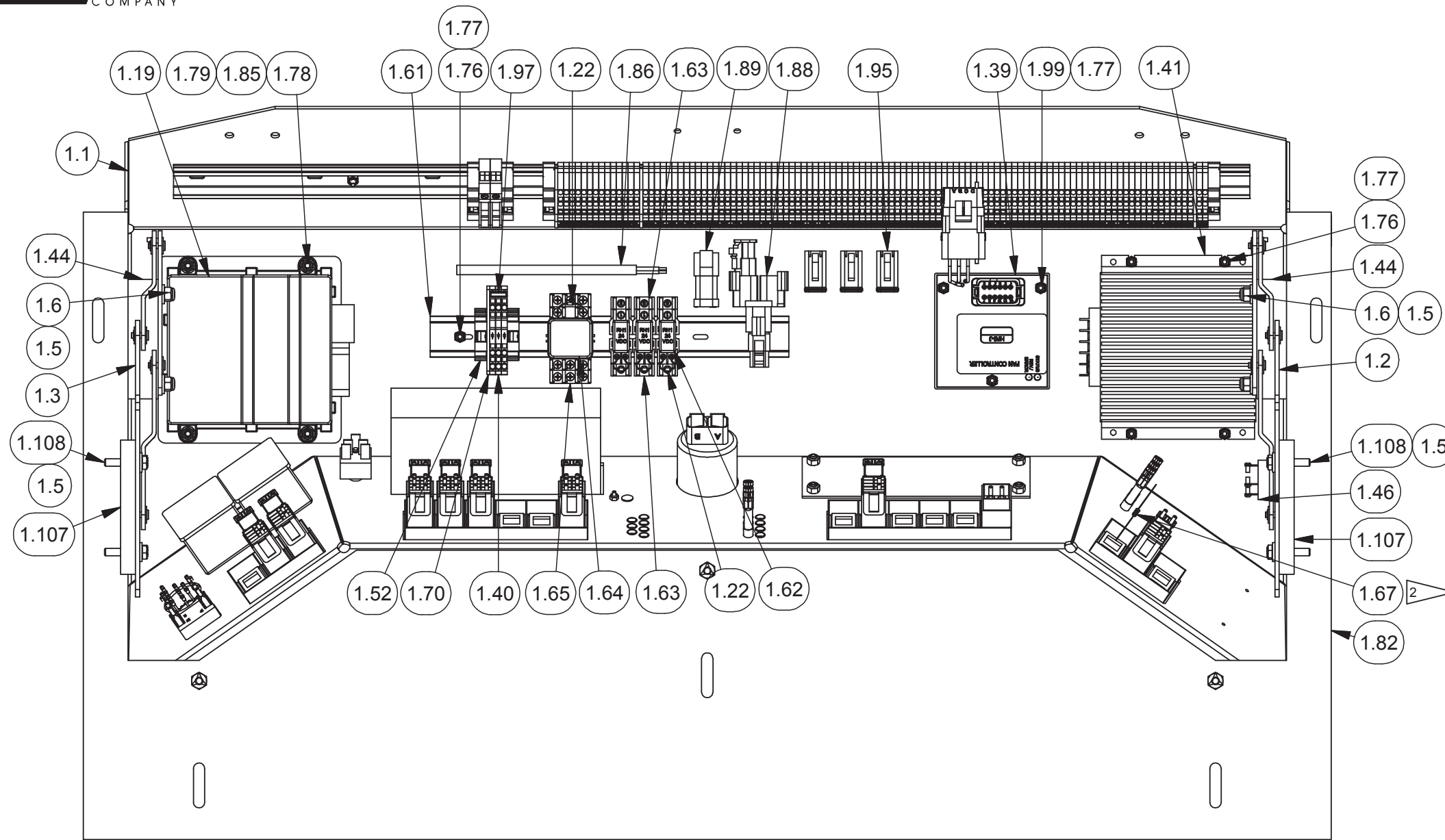
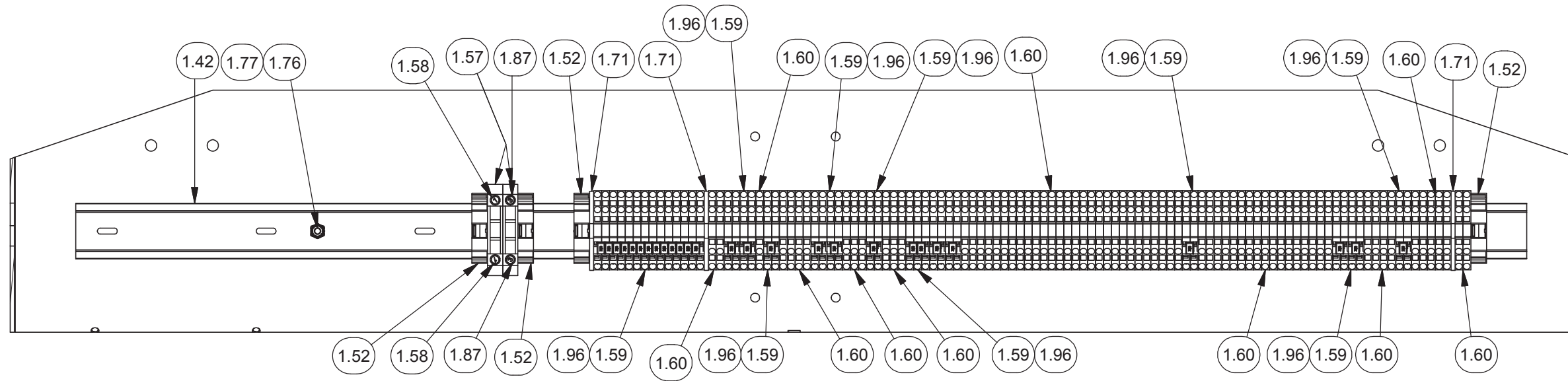

A



SECTION 3A-3A

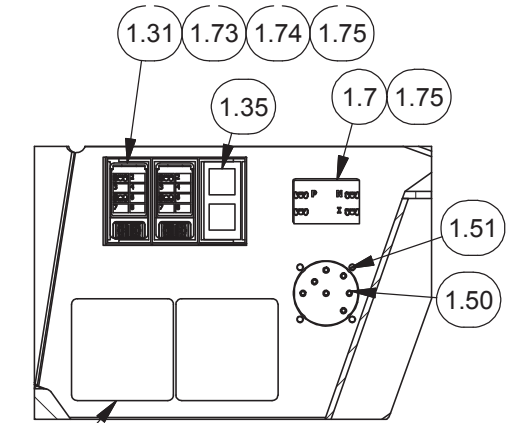

SECTION 3C-3C

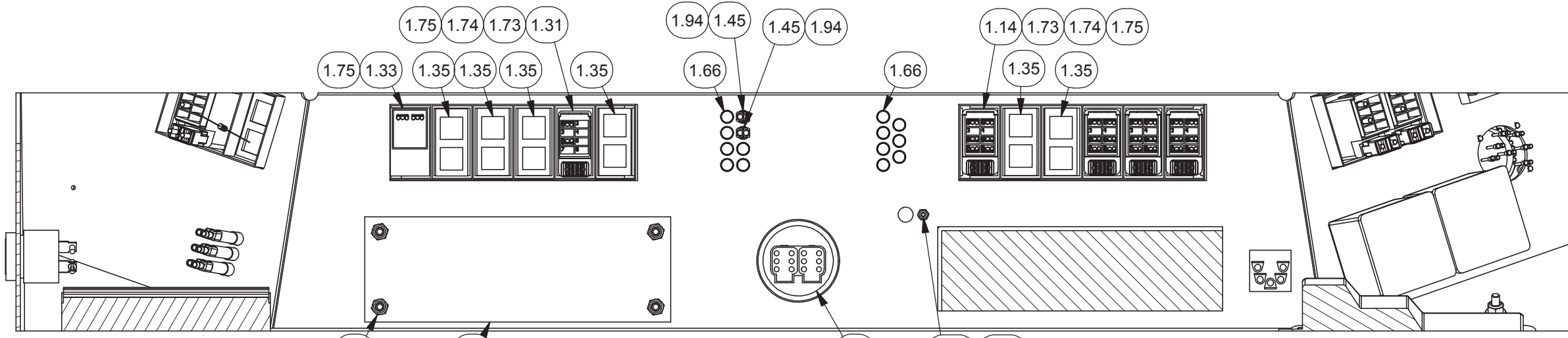

SECTION 3B-3B

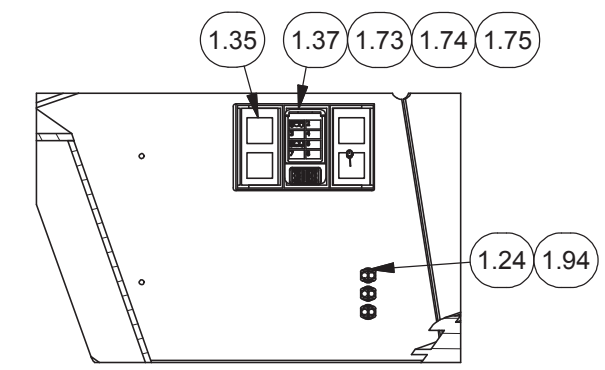

SECTION 3D-3D

