

Cylinder Assembly, HD

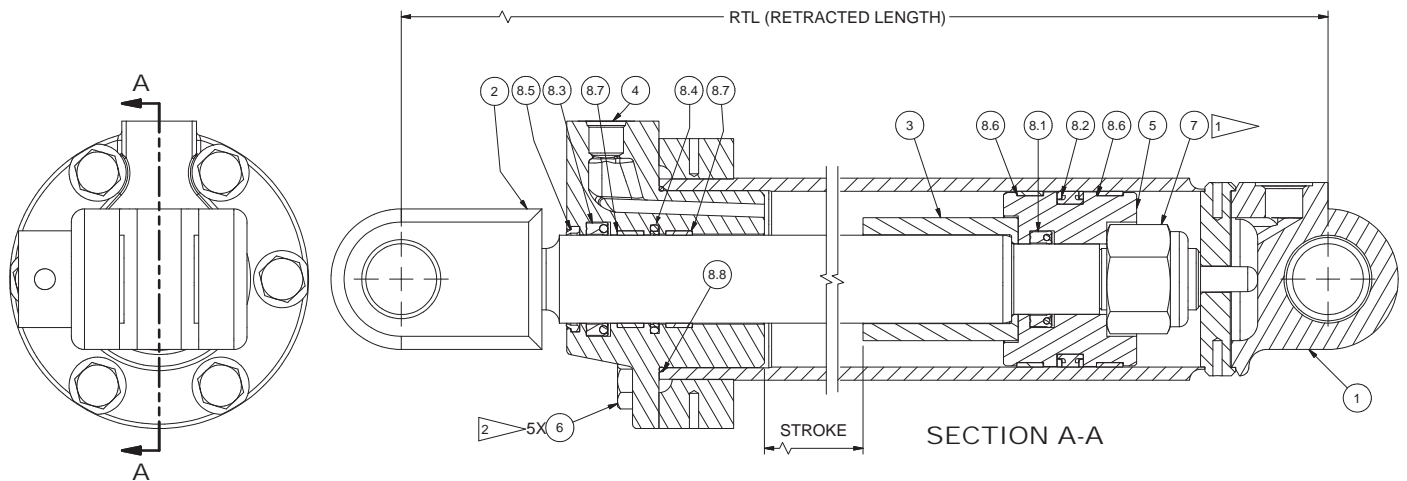
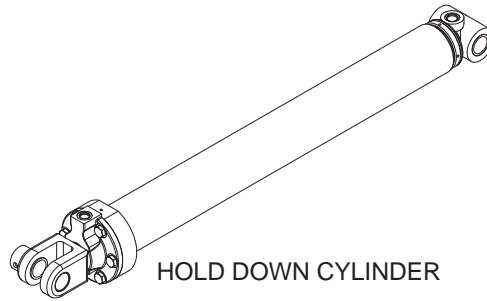

NOTE:

1. TORQUE NUT TO 1400 FT-LB

2. REMOVE DIRT, LOOSE SCALE, BURRS, AND PAINT FROM MATING SURFACES OF BOLTED JOINTS. USE MEDIUM STRENGTH LOCTITE THREADLOCKER 242 (BLUE).

Item	Part No.	Qty	Description	Item	Part No.	Qty	Description
	594498		Cylinder Assembly, HD				
1	590516	1	. Barrel	8	590576	1	. Kit, Packing
1.1	505664	2	.. Bushing	8.1	Y437152.129	1	.. Seal
2	590514	1	. Stem	8.2	69770.0500	1	.. Seal, Piston
2.1	505880	2	.. Bushing	8.3	251514	1	.. Seal
3	594501	1	. Tube, Stop	8.4	69768.0250	1	.. Seal, Buffer
4	591505	1	. Packing Gland	8.5	20545	1	.. Wiper Ring
5	590553	1	. Piston	8.6	70384.0500	2	.. Wear Ring, Piston
6	293710W	6	. Capscrew	8.7	70385.0250	2	.. Wear Ring, Rod
7	219929	1	. Nut, Esna	8.8	233126	1	.. O-Ring