

NOTES:
 1) TERMINALS WITH THE SAME NUMBER IN THE CB PANEL AND OVERHEAD SHOULD BE CONNECTED.
 2) WIRE HARNESS CONNECTORS ARE LABELED AS: HARNESS LETTER[CONNECTOR LETTER]PIN NUMBER. REFERENCE WIRING LIST 590321 FOR CONNECTOR CROSS REFERENCE.
 3) 12 & 6 PIN BUSSED CONNECTORS HAVE TWO BUSSES. 12 PIN CONNECTORS: PINS 1,2,3,10,11,12 & 4,5,6,7,8,9 ARE BUSSED. 6 PIN CONNECTORS: PINS 1,2,6 & 3,4,5 ARE BUSSED.

OVERHEAD CONSOLE

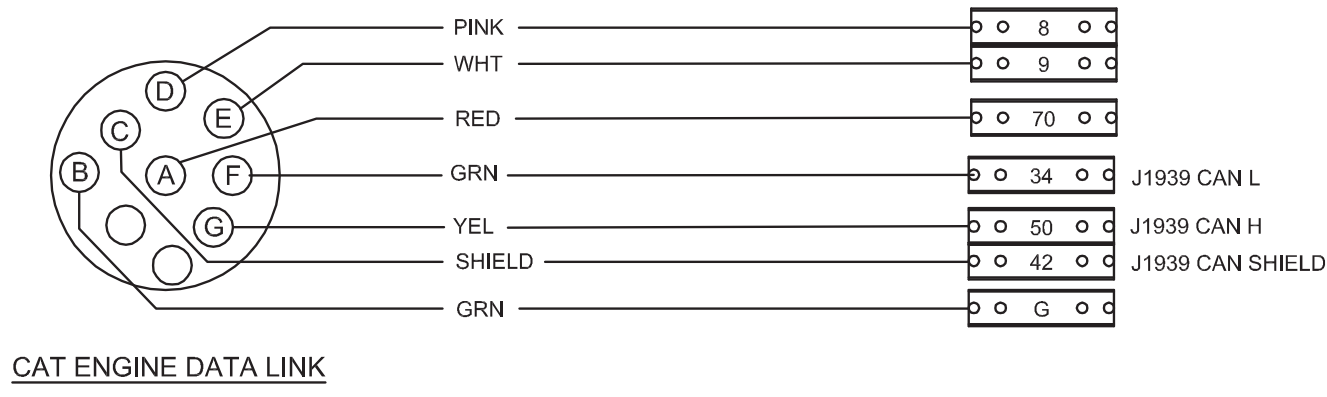

SEAT

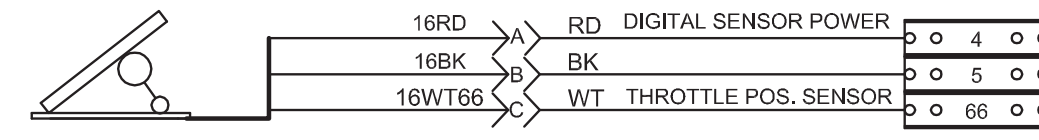

CAB ECM

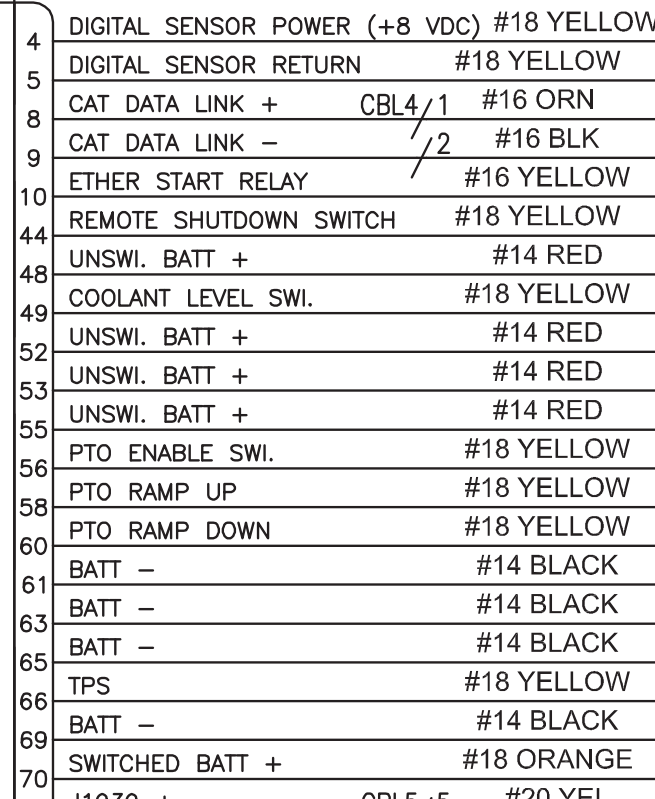

ENG ECM

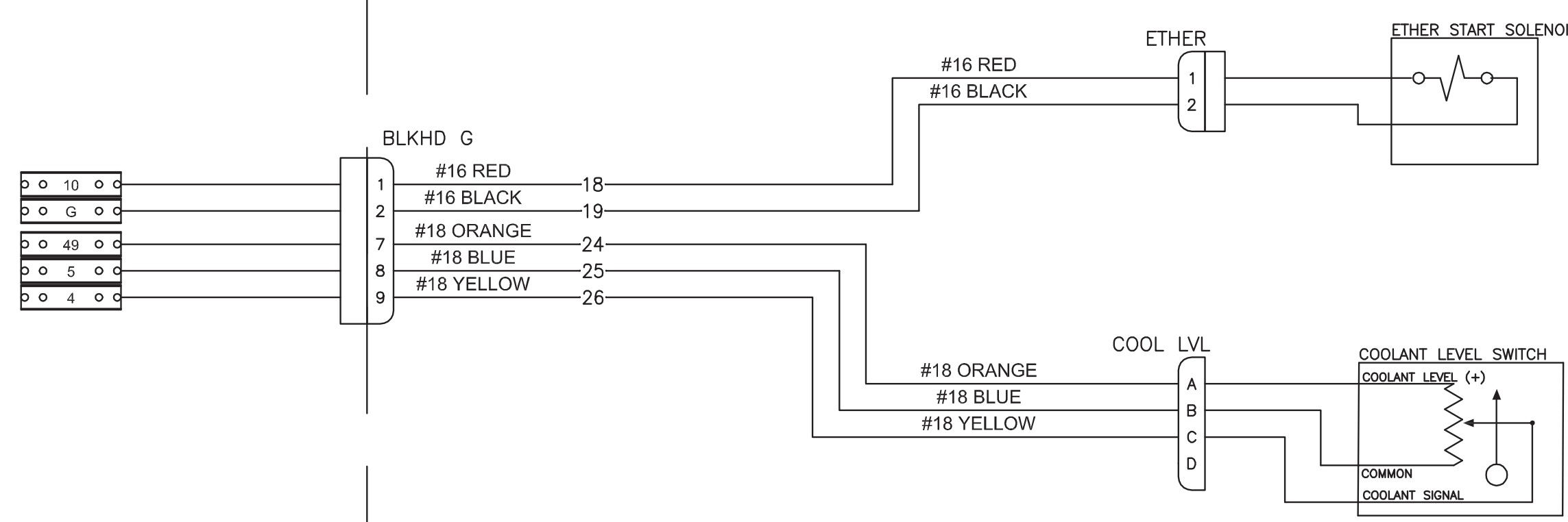
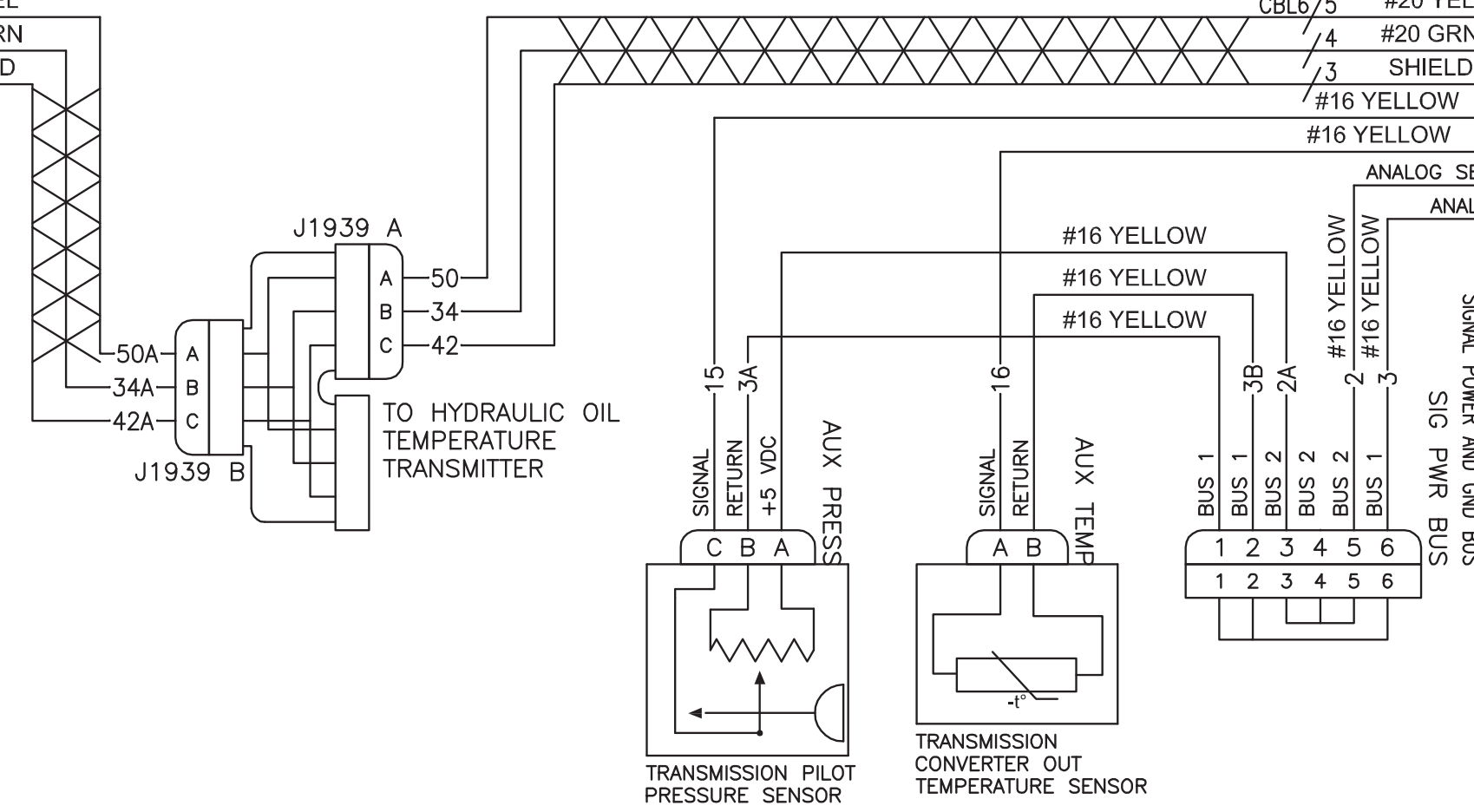
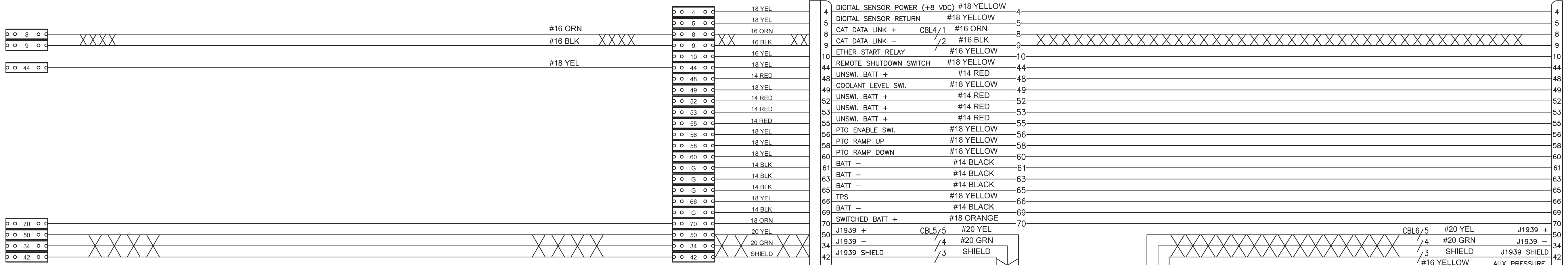
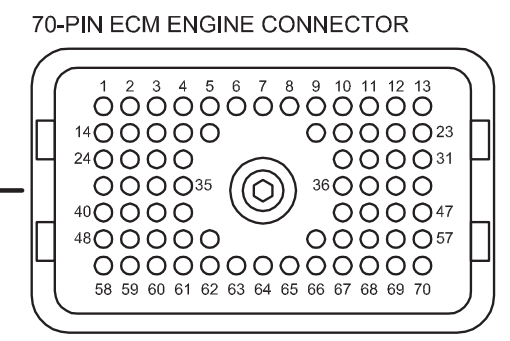

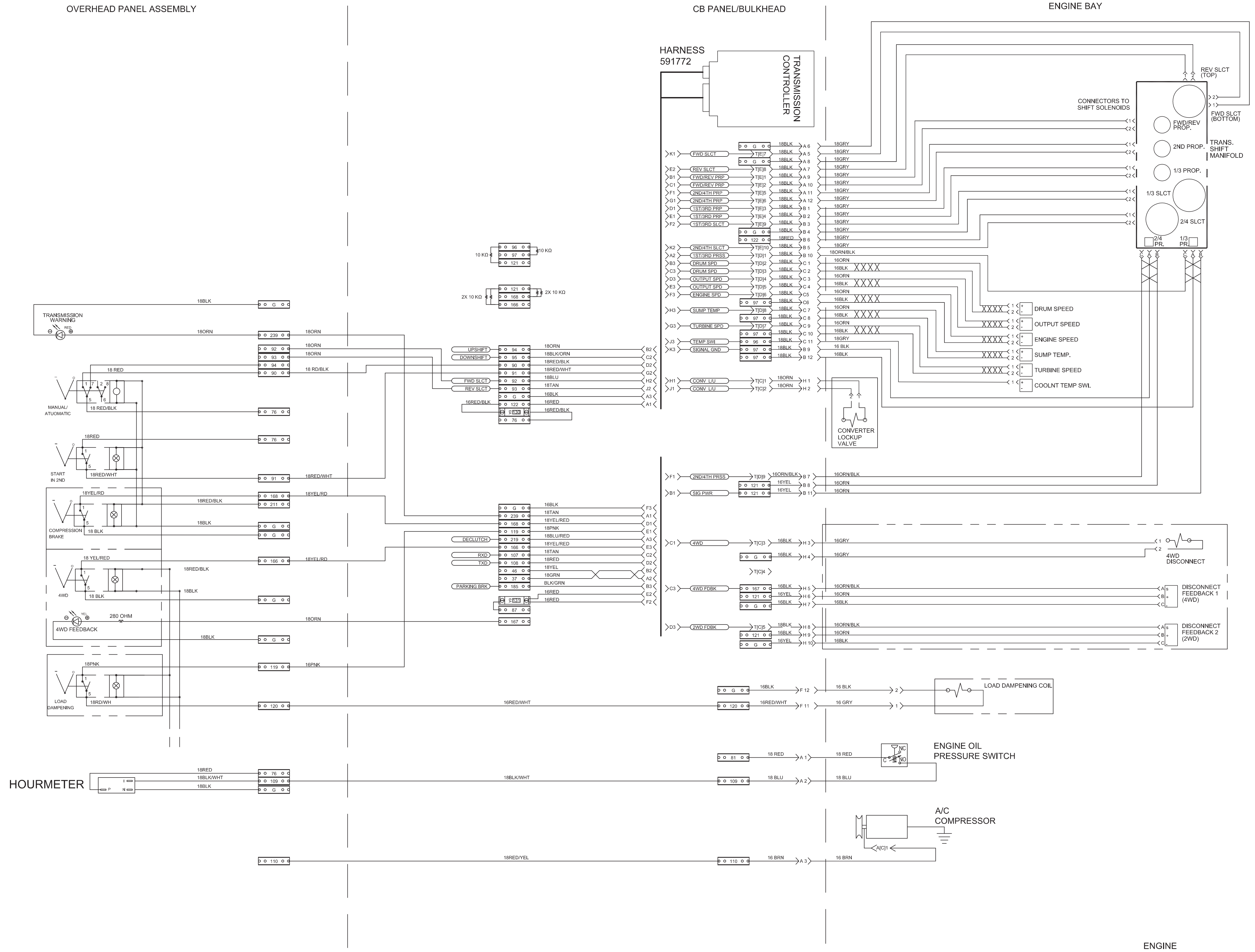

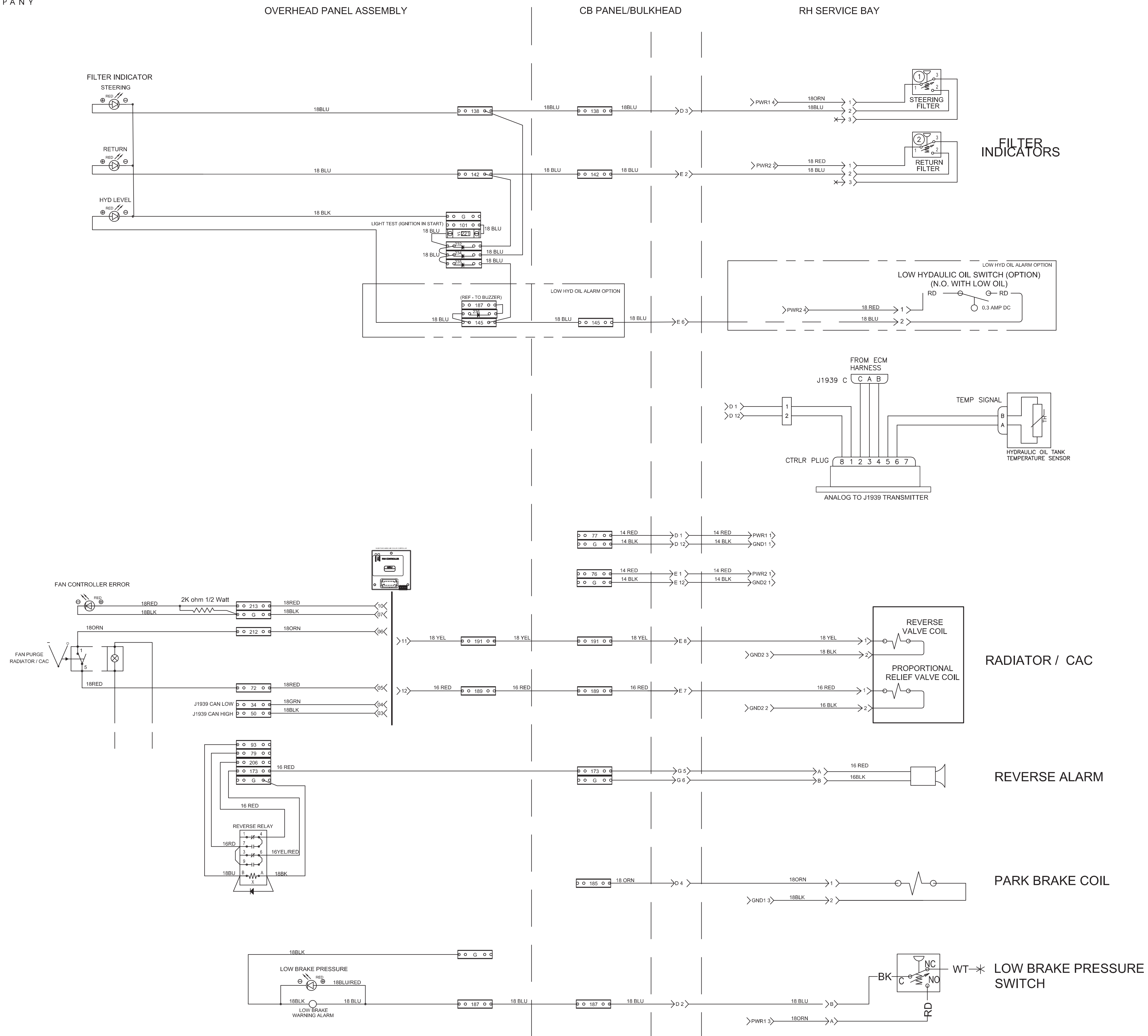

OVERHEAD PANEL ASSEMBLY

CB PANEL/BULKHEAD

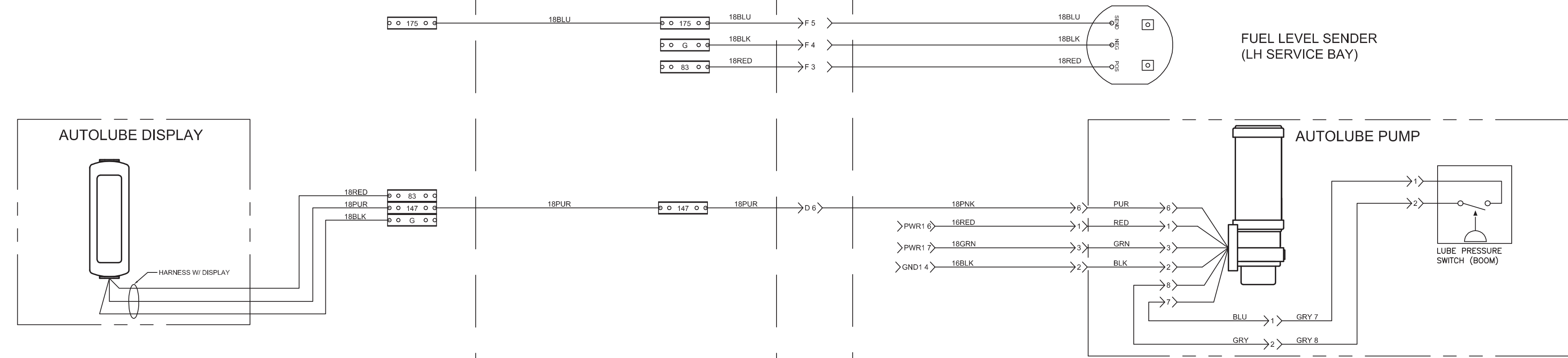
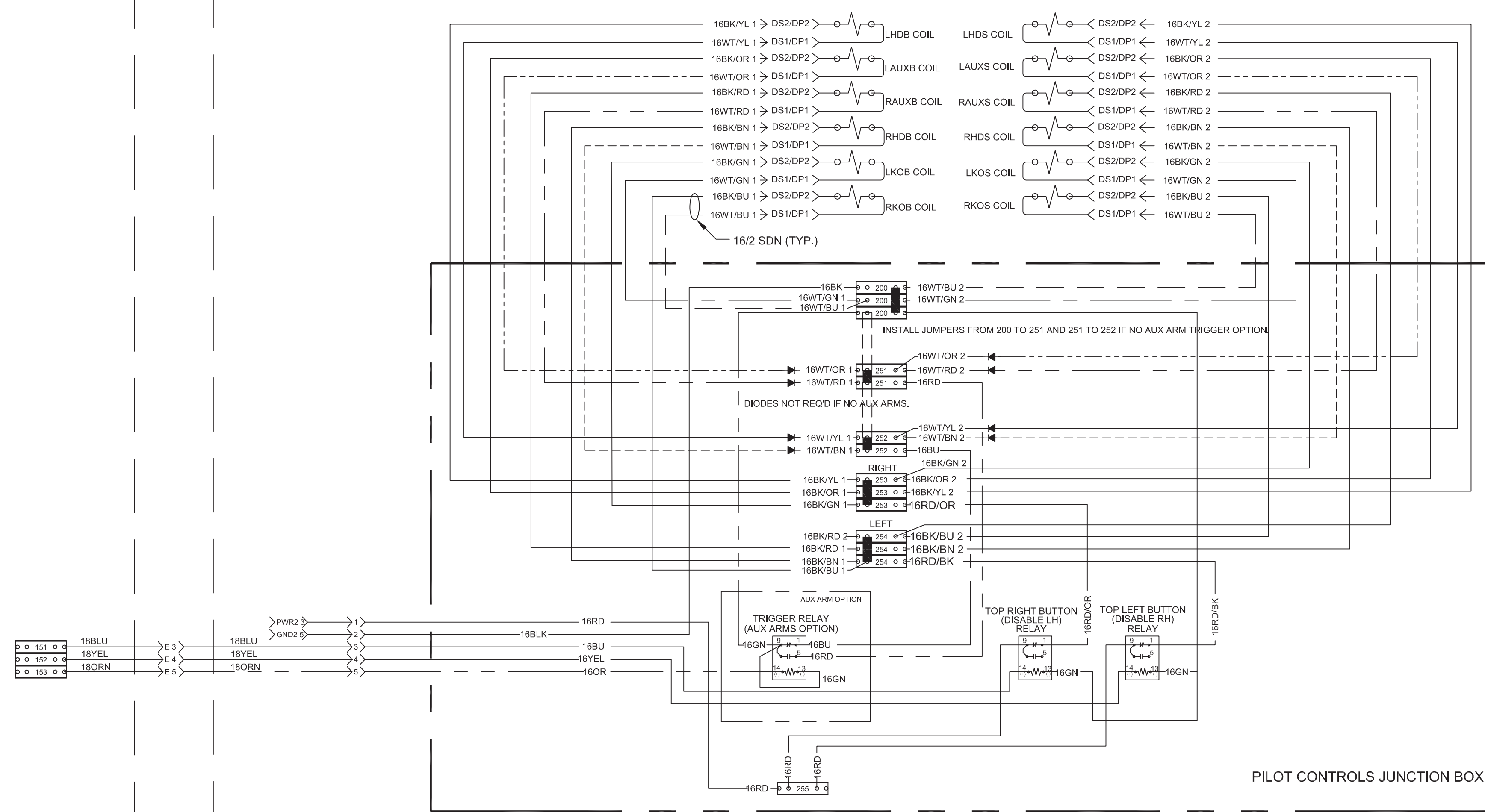

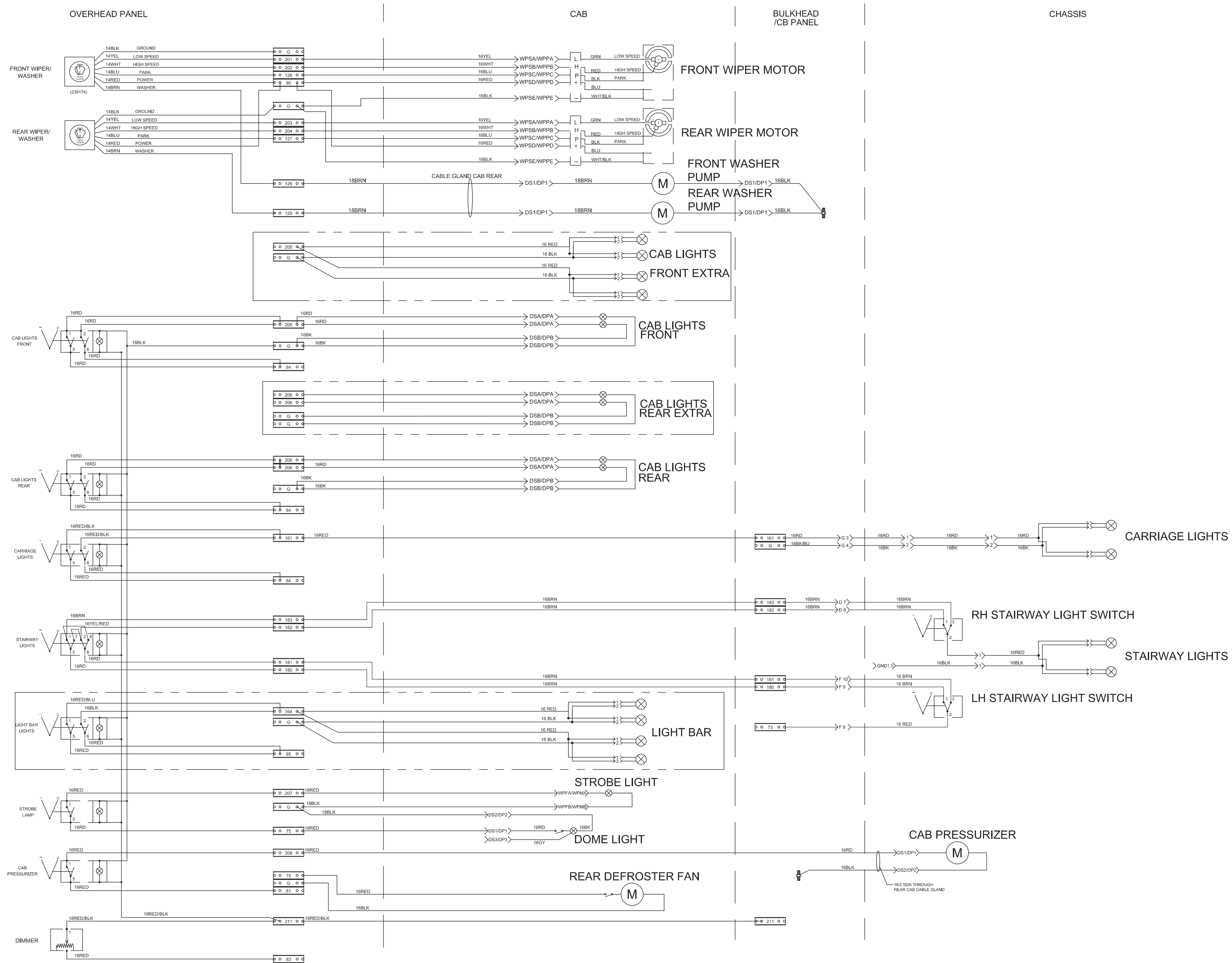

LOWER DASH

OVERHEAD PANEL

IN CAB

OUTSIDE CAB

