

Axle Installation

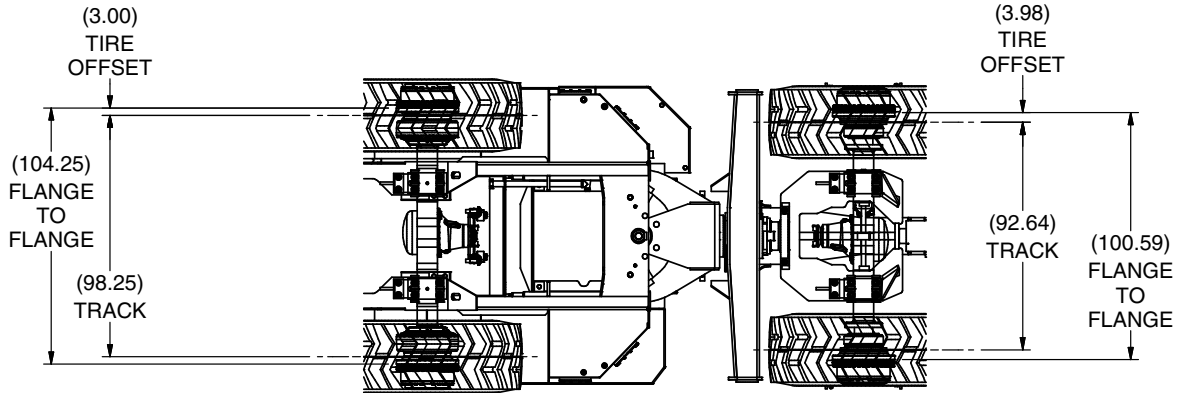

TRACK WIDTH

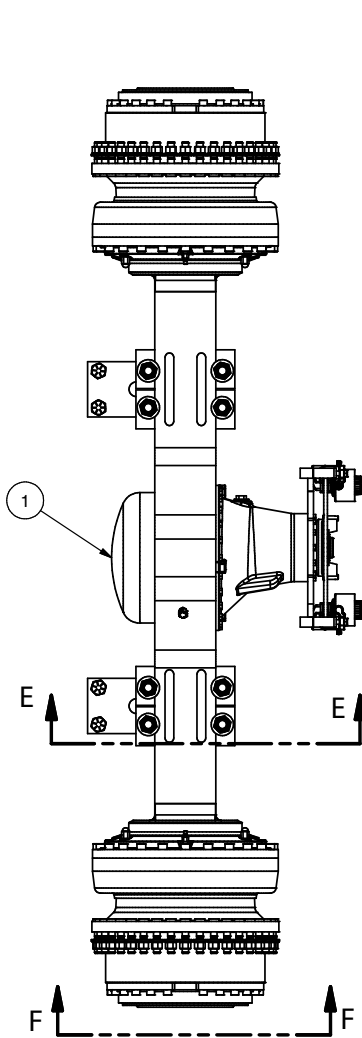

NOTES:

- 1. TORQUE ITEM 3 AND 9 TO 3210 - 3370 FT/LBS.
- 2. TORQUE ITEM 11 TO 1640 - 1720 FT/LBS.
- 3. TORQUE ITEM 17 480 - 500 FT/LBS.

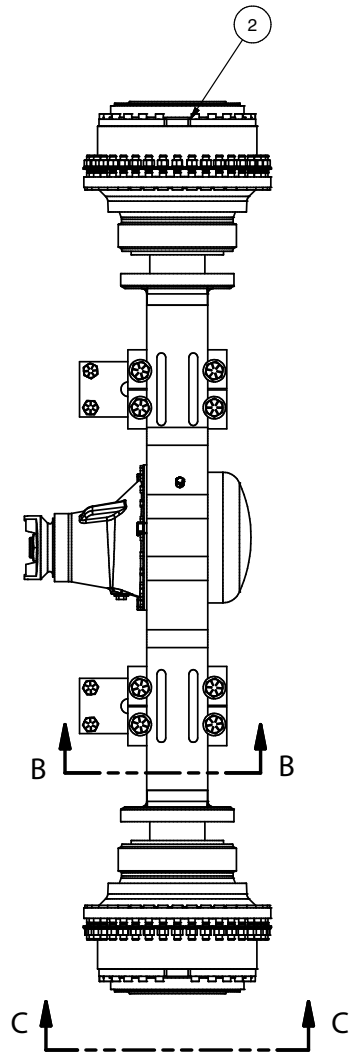

Item	Part No.	Qty	Description	Item	Part No.	Qty	Description
<b>594018 Axle Installation</b>							
1	* 594016	1	. Axle, Nospin, Rear	10	568770	4	. Link
2	* 594014	1	. Axle, Front	11	2300478W	8	. Capscrew
3	596614	12	. Capscrew	12	220918	8	. Nut, Esna
5	234536	32	. Hard Washer	13	225851	8	. Hard Washer
6	220448	16	. Nut	17	591870	152	. Nut, Wheel
9	596604	4	. Capscrew				

\* See Separate Coverage

# Axle Installation

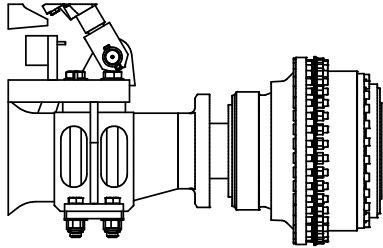

**VIEW A-A  
FRONT AXLE  
BOTH SIDES**

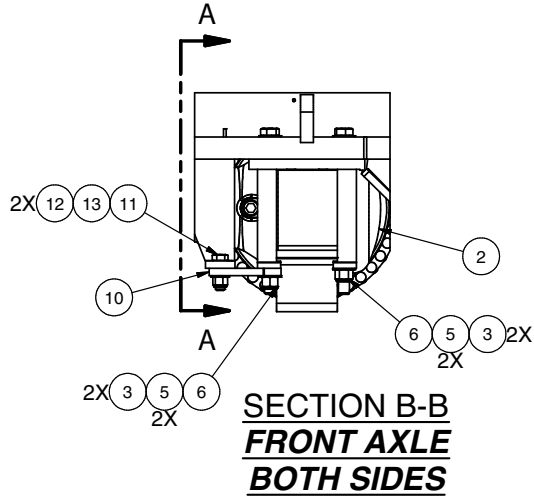

**SECTION B-B  
FRONT AXLE  
BOTH SIDES**

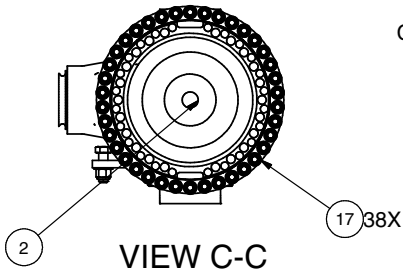

**VIEW C-C  
FRONT AXLE  
BOTH SIDES**

BREATHER  
COMES W/ AXLE

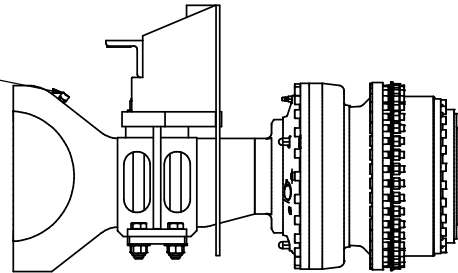

**VIEW D-D  
REAR AXLE  
BOTH SIDES**

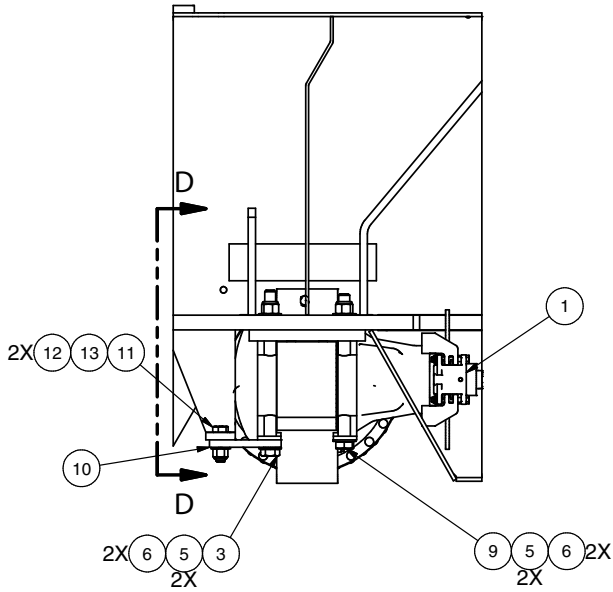

**SECTION E-E  
REAR AXLE  
BOTH SIDES**

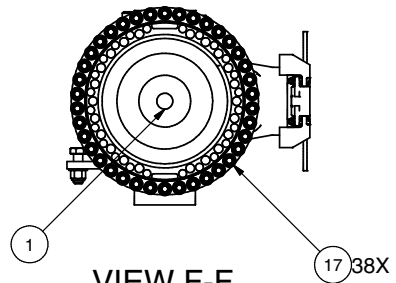

**VIEW F-F  
REAR AXLE  
BOTH SIDES**