

Kit, Cylinder Seal Retrofit

**TORQUE REQUIREMENT NOTE:**

1: USE MEDIUM STRENGTH BLUE LOCTITE 242 AND TORQUE TO 1,400 FT-LBS

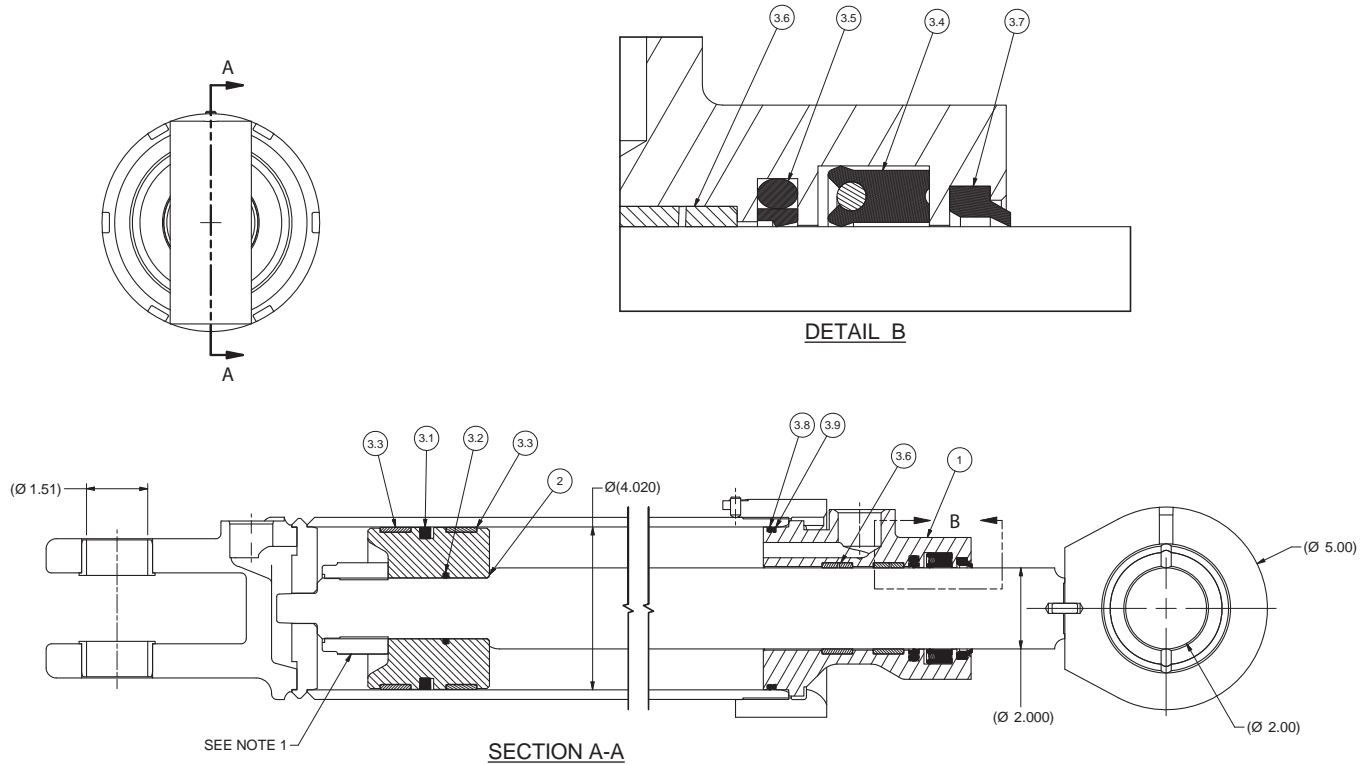

**SERVICE NOTE:**  
 THIS KIT IS USED TO RETROFIT 4.020 NOMINAL BORE CYLINDERS WHICH HAVE BOTH PACKING GLAND 505626 AND PISTONS 506562 AND 505629 FROM VEE PACKING TO CAP SEAL PISTON SEAL AND POLYPAK GLAND SEAL.  
 SEE LONG DESCRIPTION FOR LIST OF CYLINDERS.

Item	Part No.	Qty	Description	Item	Part No.	Qty	Description
	<b>593883</b>		<b>Kit, Cylinder Seal Retrofit</b>				
1	591504	1	. Packing Gland	3.4	Y437152.129	1	.. Seal
2	593805	1	. Piston, Cylinder	3.5	69768.0200	1	.. Seal, Buffer
3	593802	1	. Kit, Packing	3.6	70385.0200	2	.. Wear Ring
3.1	593456	1	.. Seal, Piston	3.7	234593	1	.. Wiper Ring
3.2	203446	1	.. O-Ring	3.8	92482W	1	.. O-Ring
3.3	70384.0400	2	.. Wear Ring, Piston	3.9	206309	1	.. Ring, Backup