

Cylinder Assembly; Tilt

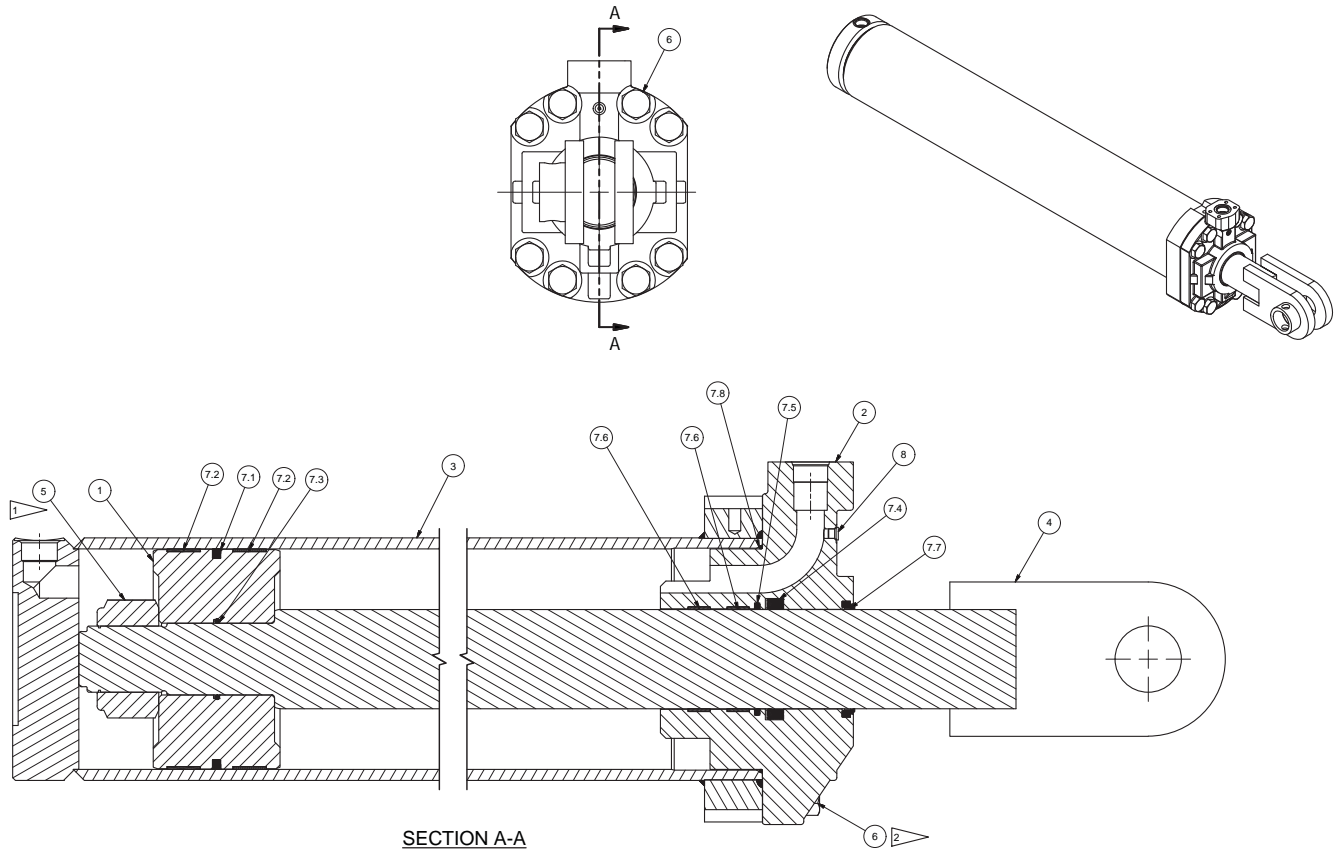

TORQUE REQUIREMENT NOTES:

- 1 ▷ TORQUE ITEM 5, 3 - 12 UN NUT TO 3,500 FT-LBS
- 2 ▷ TORQUE ITEM 6, 1 1/4 UNF CAPSCREWS TO 1,000 FT-LBS

Item	Part No.	Qty	Description	Item	Part No.	Qty	Description
	593793		Cylinder Assembly				
1	593836	1	. Piston, Cylinder	7.3	203461	1	. O-Ring
2	593837	1	. Gland, Packing	7.4	232162	1	. Seal
3	593833	1	. Weldment, Barrel & Base	7.5	69768.0450	1	. Seal, Buffer
4	593834	1	. Weldment, Stem	7.6	70385.0450	2	. Wear Ring, Rod
5	593840	1	. Nut, Esna	7.7	Y435240.57	1	. Wiper, Rod
6	230260	8	. Capscrew	7.8	14718W	1	. O-Ring
7	593838	1	. Kit, Packing	8	235387	1	. Fitting
7.1	593463	1	. Seal, Piston 10"				
7.2	70384.1000	1	. Wear Ring, Piston				