

Cylinder Assembly, HD & KO

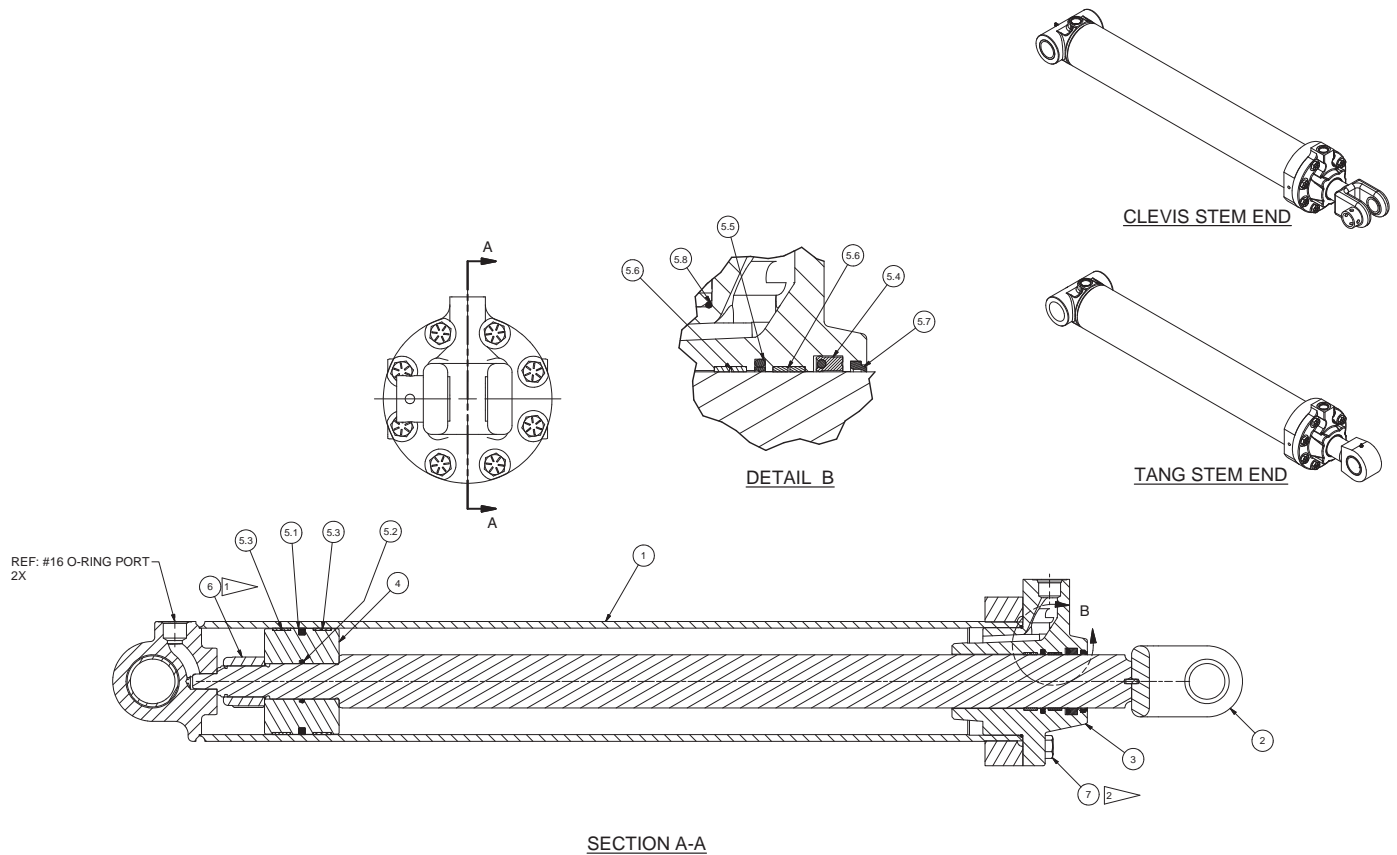

TORQUE REQUIREMENT NOTES:

- 1) TORQUE ITEM 4, 1 3/4 NF NUT TO 2,000 FT-LBS
- 2) TORQUE ITEM 5, 3/4 UNF CAPSCREWS TO 315 FT-LBS
- 3) REMOVE DIRT, LOOSE SCALE, BURRS AND PAINT FROM THE MATING SURFACES OF BOLTED JOINTS.
- 4) USE MEDIUM STRENGTH BLUE LOCTITE 242.

Item	Part No.	Qty	Description	Item	Part No.	Qty	Description
	593792		Cylinder Assembly, HD & KO				
1	593829	1	. Weldment, Barrel & Base	5.4	222959	1	. Seal
2	593798	1	. Weldment, Stem	5.5	69768.0300	1	. Seal, Buffer
3	593801	1	. Gland, Packing	5.6	70385.0300	2	. Wear Ring, Rod
4	593788	1	. Piston, Cylinder	5.7	222957	1	. Wiper, Rod
5	593808	1	. Kit, Packing	5.8	203549	1	. O-Ring
5.1	593458	1	. Seal, Piston	6	219929	1	. Nut, Esna
5.2	203451	1	. O-Ring	7	221660W	8	. Capscrew
5.3	70384.0600	2	. Wear Ring, Piston				