Cab Assembly

Cab Assembly

Item	Part No.	Qty	Description	Item	Part No.	Qty	Description
	591868		Cab Assembly				
1	586283	1	. Cab Weldment, Modular	60	223146	2	. Machine Screw
2	* 586385	1	. Window Installation	66	* 589284	1	. Panel Assembly, Circuit Braker
3	258667	4	. Stud	67	588153	1	. Plate, RH Lower Panel
4	586990	1	. Plate,Cover RH	68	588152	1	. Plate, LH Lower Panel
5	258697	388IN	. Gasket	70	* 588138	1	. Panel Assembly, LH Front
7	258712	2	. Pin, Striker	71	* 588137	1	. Panel Assembly, RH Front
8	258713	2	. Guard, Striker	72	586597	1	. Cover Weldment
9	586991	1	. Plate,Cover LH	73	258860	2	. Cam Latch Assembly
10	R10581	2	. Stud, Battery Feeder	80	* 587926	1	. Panel Assembly, LH
11	254962	1	. Connector, ECM	81	257710	1	. Wire Harness, Powerview Jumper
12	587033	2	. Shaft, Stand-Off	83	586814	1	. Plate, Mounting
13	256319	2	. Receptacle	84	586815	2	. Plate, Vent
16	259262	4	. Jam Nut	87	590052	4	. Stop, Door
17	259263	8	. Machine Screw	88	* NA	0	. Seat, Training
18	259264	8	. Nut, Esna	90	R13811189	24	. Locknut
19	296148W	8	. Capscrew	91	221763W	40	. Washer
20	320152W	8	. Washer	92	Y25G-0406	8	. Capscrew
21	587034	2	. Jam Nut	93	241059	26	. Insert
22	590724	2	. Motor , Wiper	94	R13809543	2	. Locknut
23	258773	1	. Arm Assembly, Wiper	95	Y09G-(1024)08	2	. Capscrew
24	258774	2	. Blade Assembly, Wiper	96	240983	25	. Insert
25	258434	4	. Spacer	99	18699W	4	. Capscrew
26	256320	1	. Light, Dome	100	223099	4	. Lockwasher
27	587119	1	. Arm Assembly, Wiper	101	224120W	5	. Capscrew
28	* 586437	1	. Panel Assembly, LH	103	R13811034	36	. Capscrew
29	* 587924	1	. Panel Assembly, RH Gauge	105	221767W	44	. Hard Washer
30	* 587925	1	. Panel Assembly, RH	106	223428	34	. Flat Washer
31	249776	2	. Nozzle, Jet, Single	109	R13811014	34	. Capscrew
32	* 591401	1	. Door Assembly, RH	112	258706	2	. Louver, Ball
33	* 591402	1	. Door Assembly, LH	113	221754	12	. Capscrew
34	* 591314	1	. Console Assembly, Overhead	114	234197	4	. Flat Washer
35	* 586558	3	. Hinge Assembly	117	238437	4	. Nut, Esna
36	* 586560	3	. Hinge Assembly	118	R13813167	4	. Machine Screw
37	586583	12	. Pad, Hinge	119	Y25G-0414	8	. Capscrew
38	18720W	17	. Capscrew	120	249395	24	. Capscrew
40	2301055W	10'	. Vinyl Protective Trim	125	222470	13	. Insert
41	258919	2	. Housing, Brg	126	16828W	8	. Capscrew
42	258920	2	. Lever, Clamp	127	586806	2	. Bar,Spacer
43	258921	4	. Washer, Thrust	128	* 590011	4	. Door Spring Assembly
44	258922	2	. Shaft, Flanged	129	* 586962	1	. Insulation Installation
45	258923	1	. Latch, LH Rotary	130	* 588628	1	. Insulation Installation
46	258924	1	. Latch, RH Rotary	131	296418W	4	. Hard Washer
47	258925	1	. Spring, Ext	132	590671	1	. Plate, Spacer
48	258926	4	. Clevis	133	R13801782	6	. Capscrew
49	258928	2	. Stud	134	R13803026	4	. Clip
50	586559	2	. Plate,Arm	135	222761	1	. Sealer
51	586561	1	. Mounting Weldment,LH	136	234245	16'	. Hose, Bulk
52	586673	1	. Plate, RH Cover	137	* 590911	1	. Strobe Light & Horn Installation
53	586612	1	. Plate, LH Cover	138	590865	1	. Remote Monitor
54	586671	1	. Mounting Weldment,RH	139	Y73G-(1024)08	4	. Capscrew
55	569247	2	. Plate, Mounting	140	591902	1	. Silicone
56	R6515575	2	. Hose Clamp	141	242601	30	. Cable Tie
57	591615	2	. Bottle, Washer	142**a	NA	0	. Controller Installation
58	215774	2	. Mirror, Convex	143	592519	2	. Wire Harness
59	526939	2	. Bracket	144	593346	30	. Mount
				145	258925	1	. Stud
				146	241826	8	. Receptacle, Wedglock
				147	258925	1	. Spring

* See Seperate Coverage

*a Not Shown

NA Not Applicable

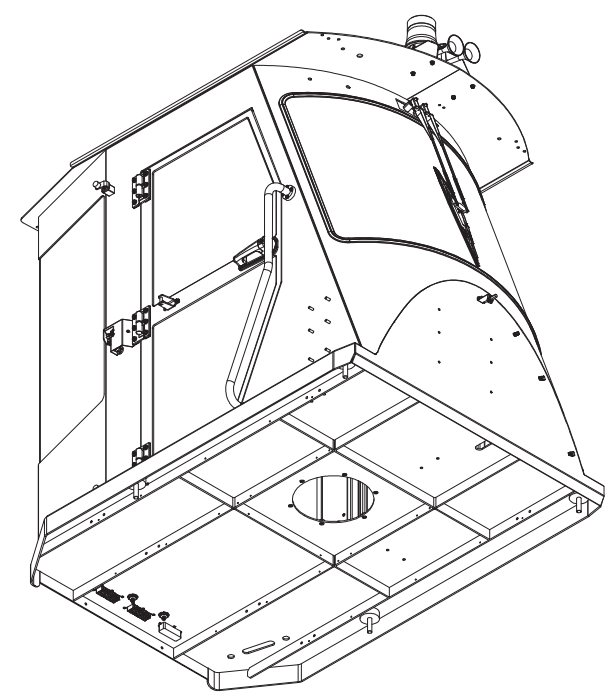
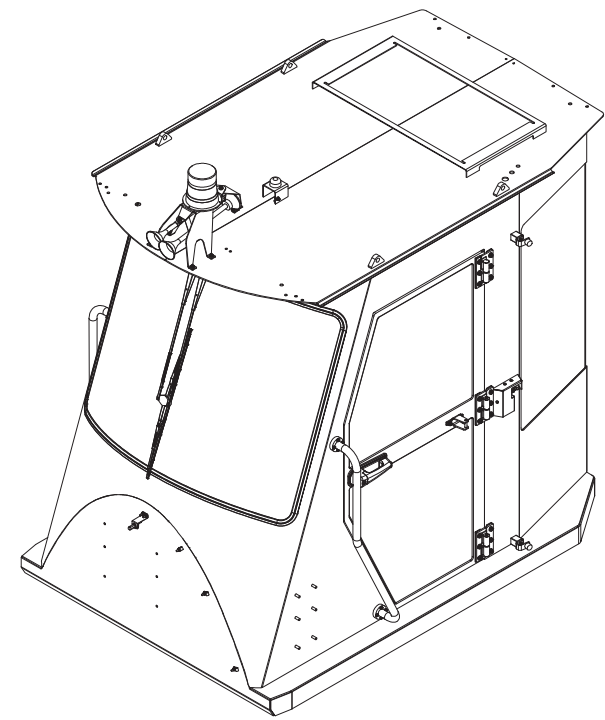
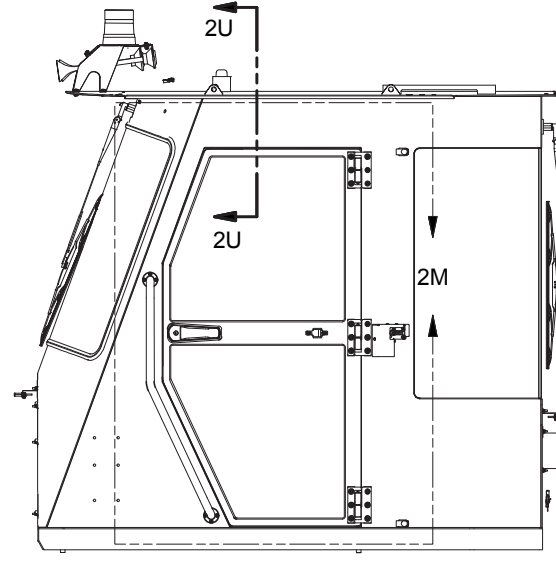
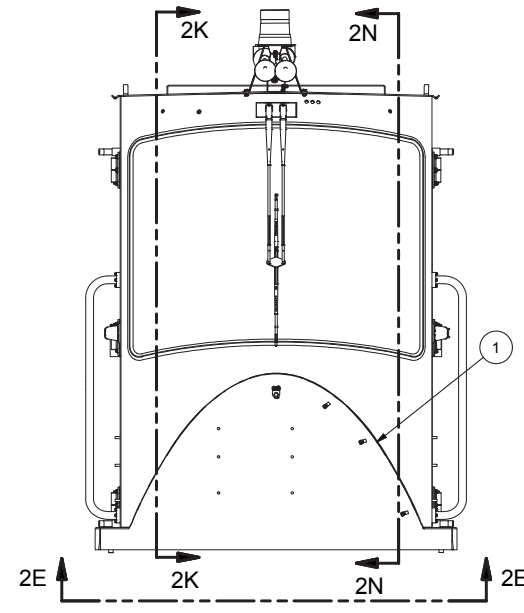
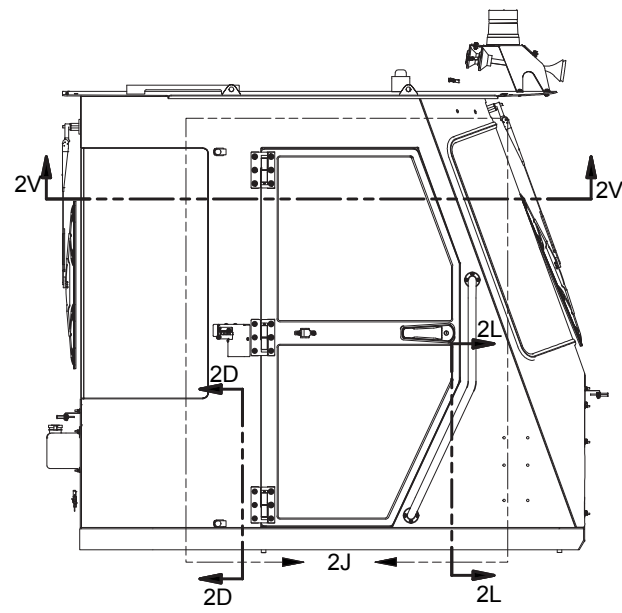

NOTES:

- 1: ITEM 88 (TRAINING SEAT) CAN BE INSTALLED ON EITHER THE LH OR RH SIDE OF THE CAB IN THE SAME MANNER.
- 2: ITEM 73 (CAM LATCH ARM) MAY HAVE TO BE SHORTENED SLIGHTLY FOR CLEAR SWEEP.
- 3: INSTALL ITEM 5 (GASKET) AS A CONTINUOUS PIECE FROM THE BOTTOM TO THE TOP OF THE REAR DOOR PILLAR, MITRE CUT AT THE TOP TO CONNECT WITH THE FRONT PORTION OF THE SEAL. LONG LEG OF GASKET TOWARD OUTSIDE OF CAB.
- 4: INSTALL ITEM 5 (GASKET) AS A CONTINUOUS PIECE FROM THE FLOOR SILL TO THE TOP OF THE REAR DOOR FRAME, WITH NO BREAKS. MITRE CUT TO CONNECT TO REAR PORTION OF THE SEAL. LONG LEG OF GASKET TOWARD OUTSIDE OF CAB.
- 5: DOOR CLEARANCE SHOULD BE UNIFORM ALL THE WAY AROUND; APPROXIMATE CLEARANCE IS 0.13". INSTALL LOWER 2 HINGES AND POSITION DOOR WITHIN OPENING AS NOTED. INSTALL TOP HINGE TO LOCK DOOR ASSEMBLY ONTO CAB. TORQUE TO 28 FT-LBS MAX.
- 6: USE ITEM 21 (NUT) TO SECURE ITEMS 43 (WASHER) & 44 (SHAFT) IN ITEM 41 (HOUSING). ITEM 43 (WASHER) HAS A GREY SIDE, AND A SILVER SIDE. THE GREY SIDE IS THE THRUST FACE, AND SHOULD BE AGAINST THE SURFACE OF ITEM 41 (HOUSING) ON BOTH SIDES OF ITEM 41 (HOUSING). DO NOT OVERTIGHTEN, SHAFT SHOULD ROTATE WITH SLIGHT RESISTANCE TO MOTION. TIGHTEN ITEM 12 (SHAFT) AGAINST ITEM 21 (NUT). APPLY BLUE 242 LOC-TITE TO ITEMS 12 & 44
- 7: ITEM 42 (LEVER) CAN BE INSTALLED AFTER ITEMS 4 & 9 (RH & LH COVERS) HAVE BEEN INSTALLED.
- 8: USING ITEMS 4 & 9 (RH & LH COVERS) AS TEMPLATES, DRILL & TAP 1/4-20 UNC HOLES IN ITEM 1 (CAB WELD'T).
- 9: IF ADJUSTMENT REQUIRED, USE FENDER WASHERS TO ADJUST SO THAT THE CUSHION IS SLIGHTLY COMPRESSED 1/8" - 1/4" WITH THE DOOR IN THE LOCKED BACK POSITION.
- 10: TO INSTALL CONSOLE, EXTEND HINGES AND BOLT HINGES TO BRACKETS ON ROOF OF ITEM 1 (CAB).
- 11: USING ITEM 34 (OVERHEAD CONSOLE) AS TEMPLATE, DRILL $\varnothing 0.394 \pm 0.003$ HOLES IN ITEM 1 (CAB WELD'T) FOR NUTSERTS.
- 12: INSTALL ITEM 3 (STUD) AT FINAL ASSEMBLY
- 13: APPLY BLUE 242 LOC-TITE
- 14: ANTENNA OF ITEM 138 MOUNTS TO TOP OF CAB. ROUTE CABLE THROUGH VINYL CLAMP, THROUGH HOLE IN CAB ROOF, THROUGH HOLE IN CAB FRONT, DOWN LEFT SIDE CABLE CHANNEL.
- 15: WIPER BLADE IS OFFSET, POSITION LONG END UP TO PREVENT BOTTOM FROM TRAVELING OFF THE BOTTOM OF THE FRONT WINDOW.
- 16: SEAL ALL-AROUND DOORWAY AS SHOWN USING (591902) AFTER PAINTING.

