

---

Cab Assembly

## Cab Assembly

Item	Part No.	Qty	Description	Item	Part No.	Qty	Description
	<b>591317</b>		<b>Cab Assembly</b>				
1	586283	1	. Cab Weldment	58	215774	2	. Mirror, Convex
2	*a 586385	1	. Window Installation	59	526939	2	. Bracket
3	258667	4	. Stud	60	223146	2	. Machine Screw
4	586990	1	. Plate, Cover RH	66	*a 589284	1	. Panel Assembly, Circuit Breaker
5	258697	388"	. Gasket	67	588153	1	. Plate, RH Lower Panel
7	258712	2	. Pin, Striker	68	588152	1	. Plate, LH Lower Panel
8	258713	2	. Guard, Striker	70	*a 588138	1	. Panel Assembly, LH Front
9	586991	1	. Plate, Cover LH	71	*a 588137	1	. Panel Assembly, RH Front
10	R10581	2	. Stud, Battery Feeder	72	586597	1	. Cover Weldment
11	254962	1	. Connector, ECM	73	258860	2	. Cam Latch Assembly
12	587033	2	. Shaft, Stand-Off	80	*a 587926	1	. Panel Assembly, LH Instrument
13	256319	2	. Receptacle	81	257710	1	. Wire Harness, Powerview Jumper
16	259262	4	. Jam Nut	83	586814	1	. Plate, Mounting
17	259263	8	. Machine Screw	84	586815	2	. Plate, Vent
18	259264	8	. Nut, Esna	87	590052	4	. Stop, Door
19	296148W	8	. Capscrew	88	na	0	. Trainer Seat Assembly
20	320152W	8	. Washer	90	R13811189	16	. Locknut
21	587034	2	. Jam Nut	91	221763W	33	. Washer
22	590724	2	. Motor, Wiper	92	Y25G-0406	8	. Capscrew
23	258773	1	. Arm Assembly, Wiper	93	241059	8	. Insert
24	258774	2	. Blade Assembly, Wiper	94	R13809543	2	. Locknut
25	258434	4	. Spacer	95	Y09G-(1024)08	2	. Capscrew
26	256320	1	. Light, Dome	96	240983	25	. Insert
27	587119	1	. Arm Assembly, Wiper	98	R13801783	4	. Capscrew
28	*a 586437	1	. Panel Assembly, LH	99	18699W	4	. Capscrew
29	*a 587924	1	. Panel Assembly, RH Gauge	100	223099	4	. Lockwasher
30	*a 587925	1	. Panel Assembly, RH Instrument	101	224120W	4	. Capscrew
31	249776	2	. Nozzle, Jet, Single	103	R13811034	36	. Capscrew
32	*a 589657	1	. Door Assembly, RH	105	221767W	44	. Washer
33	*a 589658	1	. Door Assembly, LH	106	R13802914	34	. Hard Washer
34	*a 591313	1	. Console Assembly	109	R13811014	34	. Capscrew
35	*a 586558	3	. Hinge Assembly	112	258706	2	. Louver, Ball
36	*a 586560	3	. Hinge Assembly	113	221754	12	. Capscrew
37	586583	12	. Pad, Hinge	114	234197	4	. Flat Washer
38	18720W	17	. Capscrew	117	238437	4	. Nut, Esna
39	R13810990	8	. Capscrew	118	R13813167	4	. Machine Screw
40	2301055W	10'	. Vinyl Protective Trim	119	Y25G-0414	8	. Capscrew
41	258919	2	. Housing, Bearing	120	249395	24	. Capscrew
42	258920	2	. Lever, Clamp	125	222470	17	. Insert
43	258921	4	. Washer, Thrust	126	16828W	8	. Capscrew
44	258922	2	. Shaft, Flanged	127	586806	2	. Bar, Spacer
45	258923	1	. Latch, LH Rotary	128	*a 590011	4	. Door Spring Assembly
46	258924	1	. Latch, RH Rotary	129	*a*b 586962	1	. Insulation Installation
47	258925	2	. Spring	130	*a*b 588628	1	. Insulation Installation
48	258926	4	. Clevis	131	296418W	4	. Hard Washer
49	258928	2	. Stud	132	590671	1	. Plate, Spacer
50	586559	2	. Plate, Arm	133	R13801782	2	. Capscrew
51	586561	1	. Mounting Weldment, LH	134	R13803026	3	. Clip, Insulated
52	586673	1	. Plate, RH Cover	135	222761	1	. Sealer
53	586612	1	. Plate, LH Cover	136	234245	16'	. Hose, Bulk
54	586671	1	. Mounting Weldment, RH	137	*a 590951	1	. Strobe Light & Horn Installation
55	569247	2	. Plate, Mounting	138	590865	1	. Remote Monitor
56	R6515575	2	. Hose Clamp	139	Y73G-(1024)08	4	. Capscrew
57	256408	2	. Bottle, Washer	140	R13122	4	. Flat Washer
				141	18460W	1	. Capscrew

\*a See Separate Coverage

\*b Not Shown

na Not applicable for this installation

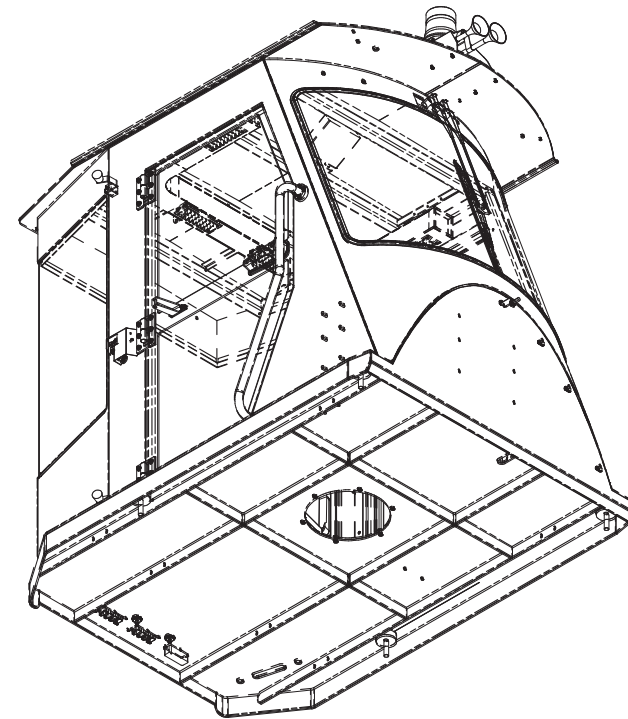
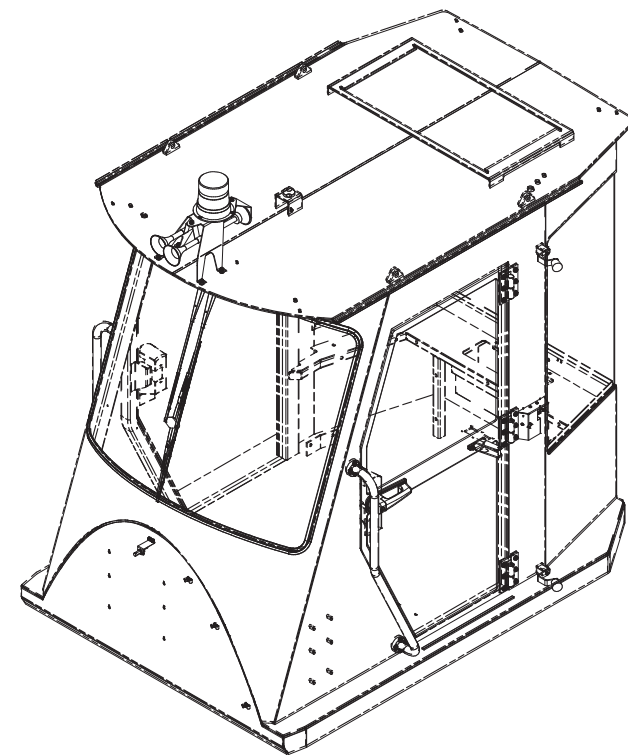
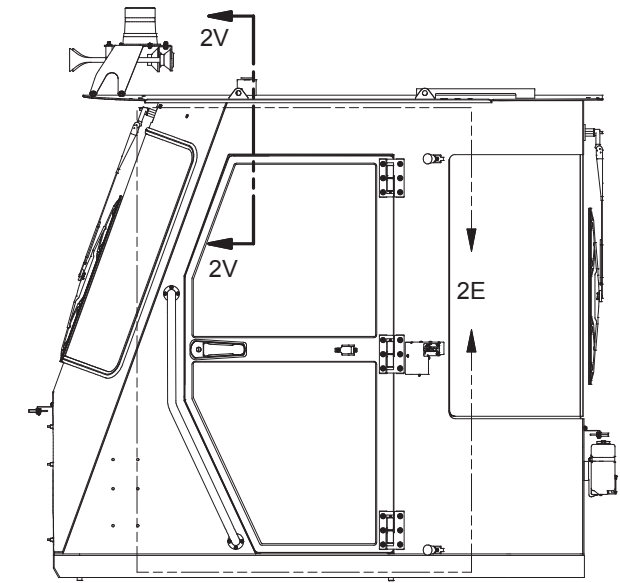
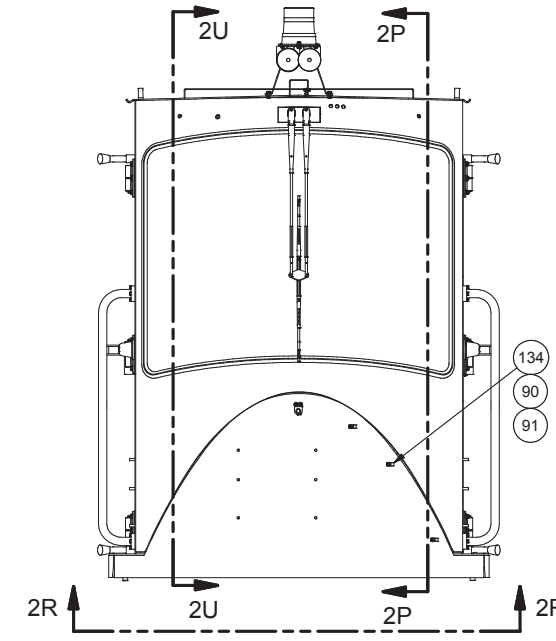
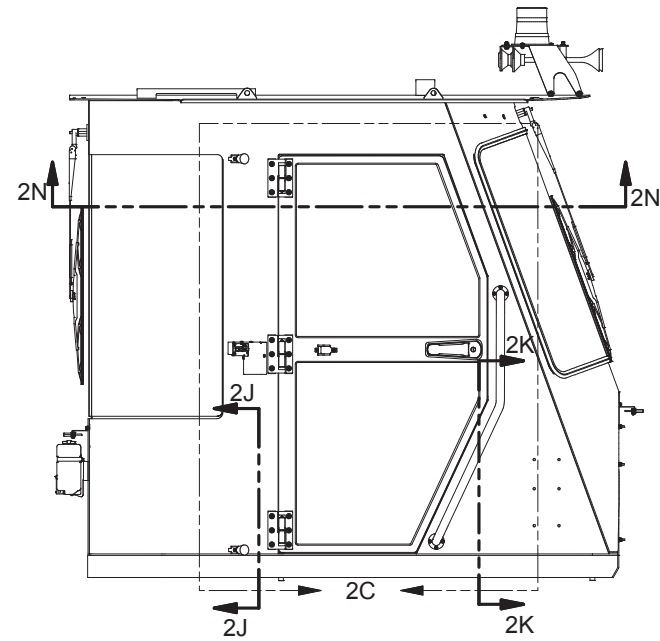

**NOTES:**

- 1: ITEM 88 (TRAINING SEAT) CAN BE INSTALLED ON EITHER THE LH OR RH SIDE OF THE CAB IN THE SAME MANNER.
- 2: ITEM 73 (CAM LATCH ARM) MAY HAVE TO BE SHORTENED SLIGHTLY FOR CLEAR SWEEP.
- 3: INSTALL ITEM 5 (GASKET) AS A CONTINUOUS PIECE FROM THE BOTTOM TO THE TOP OF THE REAR DOOR PILLAR, MITRE CUT AT THE TOP TO CONNECT WITH THE FRONT PORTION OF THE SEAL. LONG LEG OF GASKET TOWARD OUTSIDE OF CAB.
- 4: INSTALL ITEM 5 (GASKET) AS A CONTINUOUS PIECE FROM THE FLOOR SILL TO THE TOP OF THE REAR DOOR FRAME, WITH NO BREAKS. MITRE CUT TO CONNECT TO REAR PORTION OF THE SEAL. LONG LEG OF GASKET TOWARD OUTSIDE OF CAB.
- 5: DOOR CLEARANCE SHOULD BE UNIFORM ALL THE WAY AROUND; APPROXIMATE CLEARANCE IS 0.13". INSTALL LOWER 2 HINGES AND POSITION DOOR WITHIN OPENING AS NOTED. INSTALL TOP HINGE TO LOCK DOOR ASSEMBLY ONTO CAB. TORQUE TO 28 FT-LBS MAX.
- 6: USE ITEM 21 (NUT) TO SECURE ITEMS 43 (WASHER) & 44 (SHAFT) IN ITEM 41 (HOUSING). ITEM 43 (WASHER) HAS A GREY SIDE, AND A SILVER SIDE. THE GREY SIDE IS THE THRUST FACE, AND SHOULD BE AGAINST THE SURFACE OF ITEM 41 (HOUSING) ON BOTH SIDES OF ITEM 41 (HOUSING). DO NOT OVERTIGHTEN, SHAFT SHOULD ROTATE WITH SLIGHT RESISTANCE TO MOTION. TIGHTEN ITEM 12 (SHAFT) AGAINST ITEM 21 (NUT). APPLY BLUE 242 LOC-TITE TO ITEMS 12 & 44.
- 7: ITEM 42 (LEVER) CAN BE INSTALLED AFTER ITEMS 4 & 9 (RH & LH COVERS) HAVE BEEN INSTALLED.
- 8: USING ITEMS 4 & 9 (RH & LH COVERS) AS TEMPLATES, DRILL & TAP 1/4-20 UNC HOLES IN ITEM 1 (CAB WELD'T).
- 9: IF ADJUSTMENT REQUIRED, USE FENDER WASHERS TO ADJUST SO THAT THE CUSHION IS SLIGHTLY COMPRESSED 1/8" - 1/4" WITH THE DOOR IN THE LOCKED BACK POSITION.
- 10: TO INSTALL CONSOLE, EXTEND HINGES AND BOLT HINGES TO BRACKETS ON ROOF OF ITEM 1 (CAB).
- 11: USING ITEM 34 (OVERHEAD CONSOLE) AS TEMPLATE, DRILL  $\varnothing 0.394 \pm 0.003$  HOLES IN ITEM 1 (CAB WELD'T) FOR NUTSERTS.
- 12: INSTALL ITEM 3 (STUD) AT FINAL ASSEMBLY
- 13: APPLY BLUE 242 LOC-TITE
- 14: ANTENNA OF ITEM 138 MOUNTS TO TOP OF CAB. ROUTE CABLE THROUGH VINYL CLAMP, THROUGH HOLE IN CAB ROOF, THROUGH HOLE IN CAB FRONT, DOWN LEFT SIDE CABLE CHANNEL.
- 15: WIPER BLADE IS OFFSET, POSITION LONG END UP TO PREVENT BOTTOM FROM TRAVELING OFF THE BOTTOM OF THE FRONT WINDOW.

