

Cylinder Assembly, Tilt

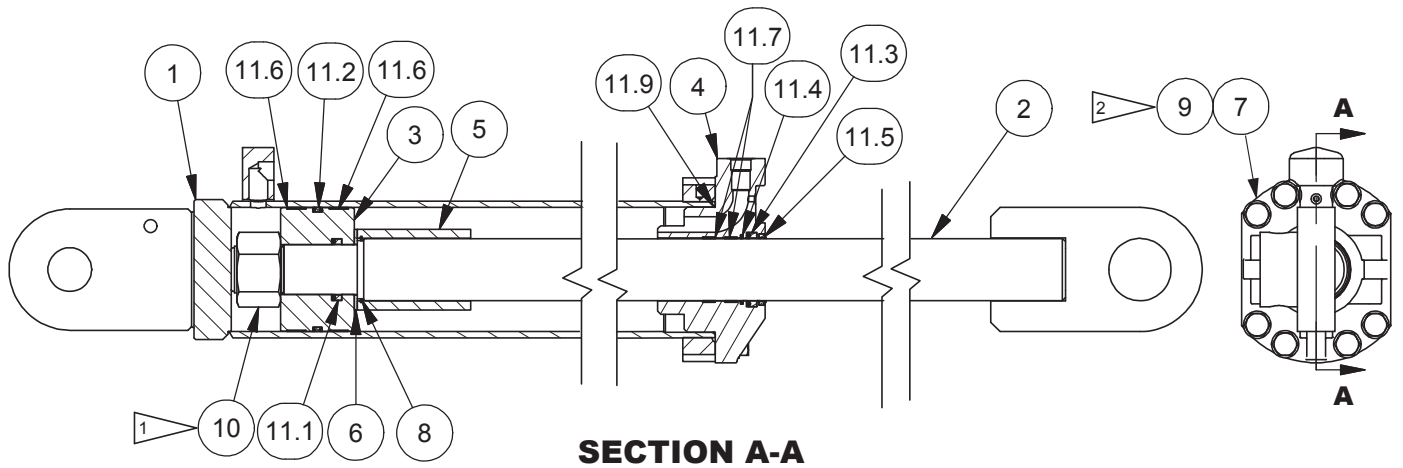

NOTE:
TORQUE NUT TO 3500 FT-LBS

TORQUE REQUIREMENT NOTE
 * TIGHTEN BOLTS TO REQUIRED TORQUE VALUE (SEE 80-1057).
 * REMOVE DIRT, LOOSE SCALE, BURRS, AND PAINT FROM THE MATING SURFACES OF BOLTED JOINTS.
 * USE MEDIUM STRENGTH LOCTITE THREADLOCKER 242 (BLUE).

Item	Part No.	Qty	Description	Item	Part No.	Qty	Description
	591059		Cylinder Assembly, Tilt	10	591445	1	. Nut, Esna
1	591060	1	. Barrel Weldment	11	591462	1	. Kit, Packing
2	591076	1	. Weldment, Stem	11.1	251459	1	.. Seal
3	591066	1	. Piston, Cylinder	11.2	69770.1000	1	.. Seal, Piston
4	592267	1	. Packing Gland	11.3	Y437152.263	1	.. Seal
5	591075	1	. Tube, Stop	11.4	69768.0500	1	.. Seal, Buffer
6	592263	1	. Washer	11.5	16298	1	.. Wiper Ring
7	2303694W	8	. Capscrew	11.6	70384.1000	2	.. Wear Ring, Piston
8	034-1042	1	. Ring, Retainer	11.7	70385.0500	2	.. Wear Ring, Rod
9	296438W	8	. Hard Washer	11.9	14718W	1	.. O-Ring