

Chassis Assembly

Chassis Assembly

Item	Part No.	Qty	Description	Item	Part No.	Qty	Description
	590919		Chassis Assembly	18	562966	1	. Dipstick Weldment
1	-----	1	. Chassis Weldment	19	565059	2	. Bushing
1.1	236307	2	.. T-Handle	22	209181	1	. Fitting
1.2	566785	1	.. Plate	23	209159	1	. Fitting
1.3	R13806980	15	.. Washer	24	209505	1	. Fitting
1.4	223654	15	.. Nut	25	238659	10	. Plug, Magnetic
1.5	R13801764	2	.. Fitting	26	13987	1	. Fitting
1.6	554520	1	.. Cover	27	209916	2	. Fitting
1.7	563775	1	.. Gasket	28	504541	1	. U-Bolt
1.8	554150	1	.. Cover	29	234307	1	. U-Bolt
1.9	555064	2	.. Gasket	30	221499W	12	. Capscrew
1.10	554445	2	.. Cover	31	221574W	4	. Capscrew
1.11	16830W	30	.. Capscrew	32	R13801901	2	. Capscrew
1.12	201569	30	.. Washer	33	R13811189	2	. Locknut
1.13	562468	1	.. Gasket	34	R13811191	18	. Locknut
1.14	562469	1	.. Cover	35	R13811193	4	. Locknut
2	563265	2	. Plate	36	R13803587	2	. Locknut
3	563186	2	. Step Assembly	37	219930	2	. Nut, Esna
4	591147	1	. Grate Weldment, Rear	38	223427	30	. Flat Washer
5	562841	4	. Handrail Weldment	39	223634	8	. Flat Washer
9	224744	1	. Filler Breather	40	231359	2	. Flat Washer
10	211398	1	. Draincock	42	* 582455	1	. Battery Box Installation
11	251714	1	. Filler Neck	43	587278	1	. Fill, Fuel Tank
12	R14340	1	. Strainer	45	563502	2	. Fender
13	R1917921	1	. Cap	46	162572W	4	. Capscrew
14	571646	1	. Tube,D/Stk	47	591252	1	. Nipple, Fuel
16	522957	2	. Lock Collar				
17	563700	2	. Pin,Stab Ear				* See Separate Coverage

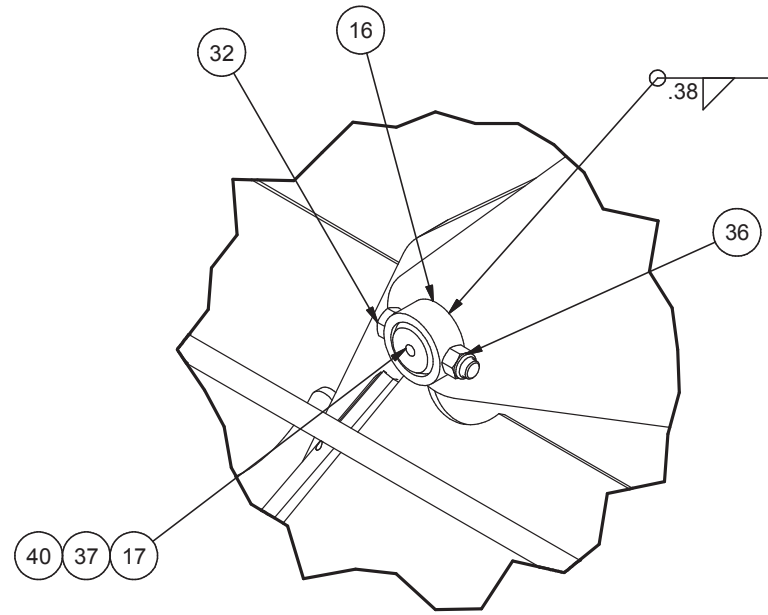
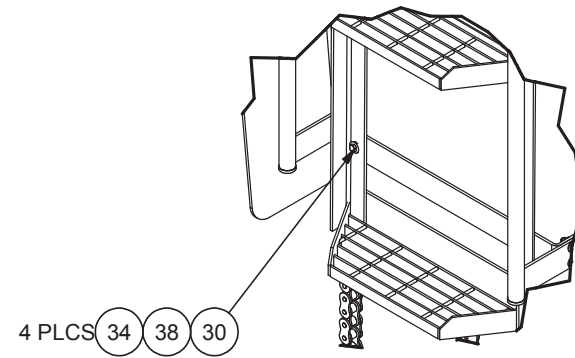

DETAIL 1A
2 PLCS



DETAIL 1B

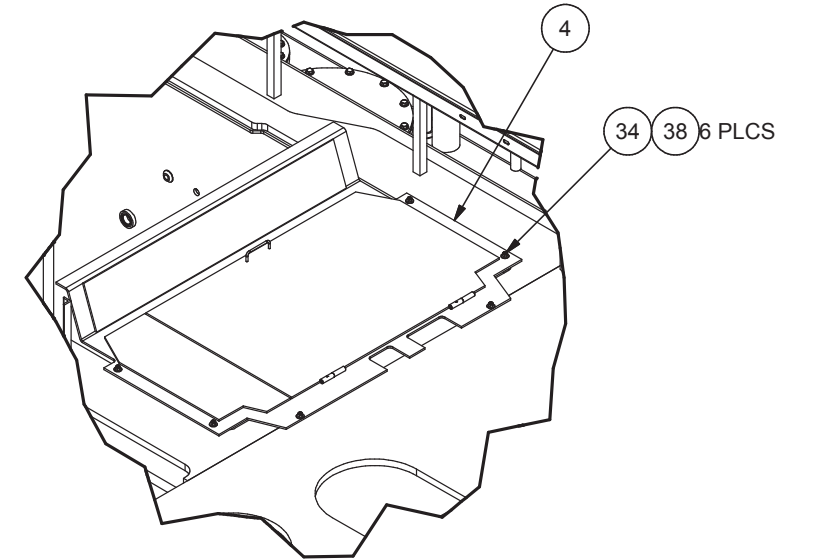

DETAIL 1C

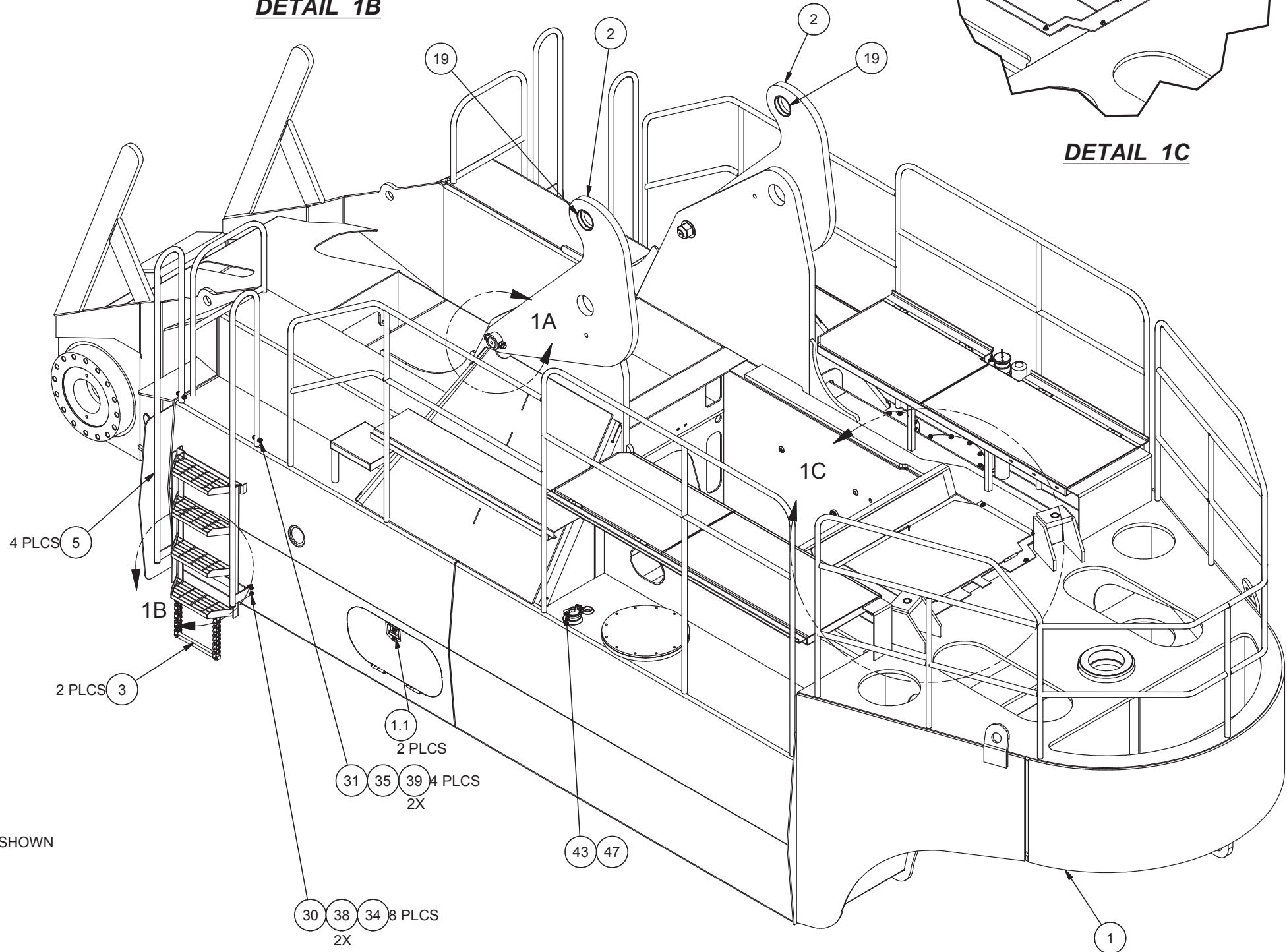

ITEM 42, BATTERY BOX IS NOT SHOWN

AD

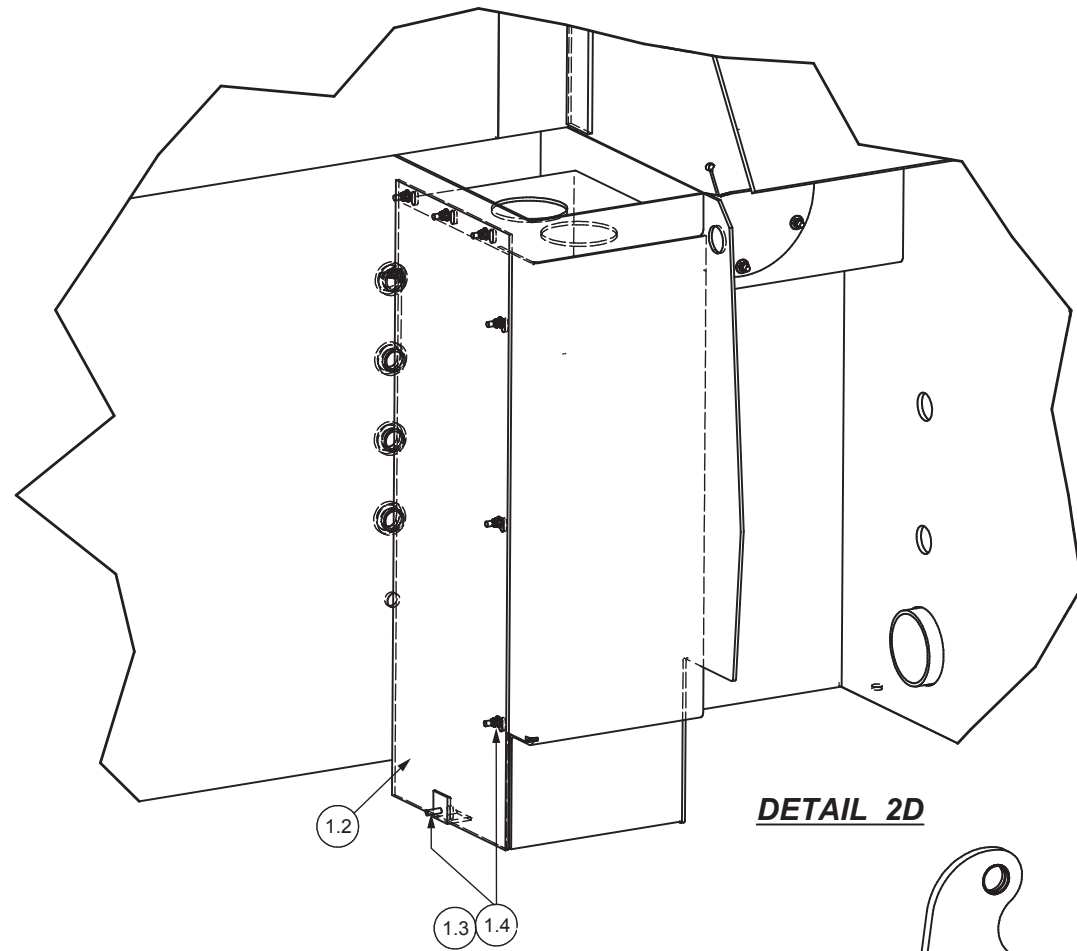

DETAIL 2D

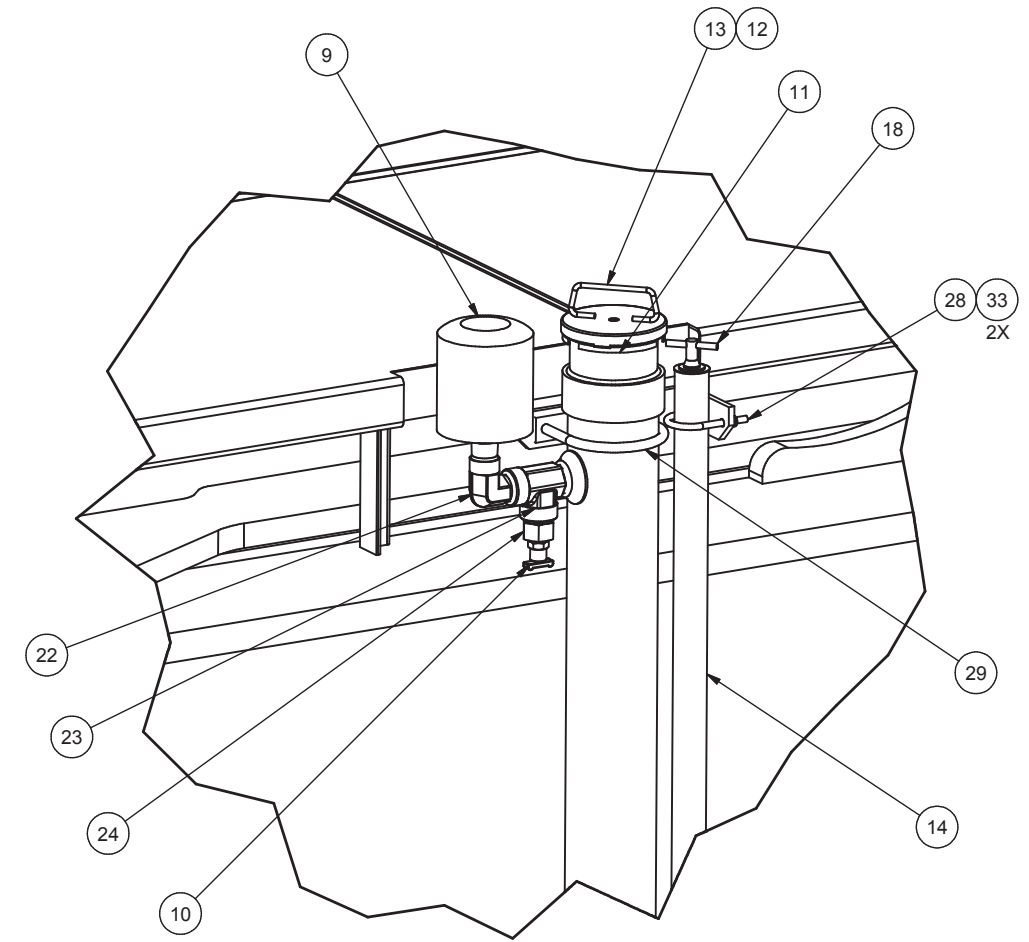

DETAIL 2E

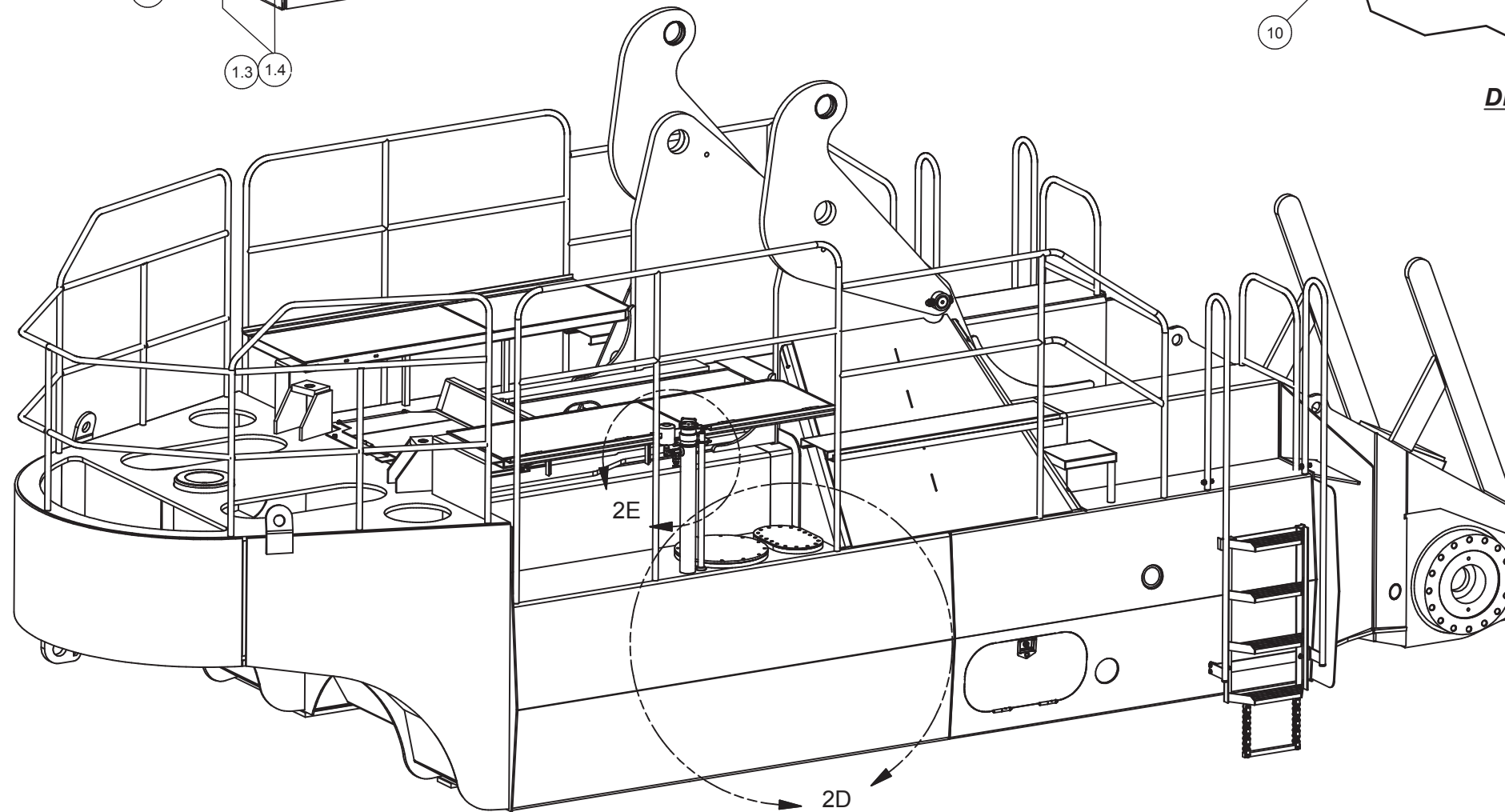

2D

AD

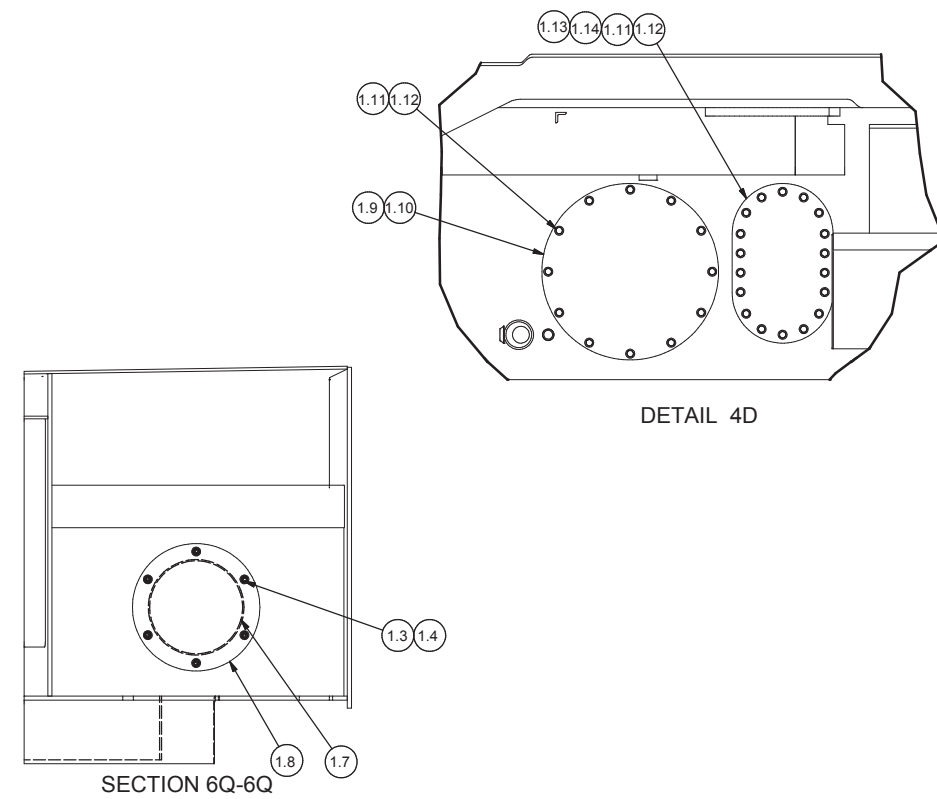
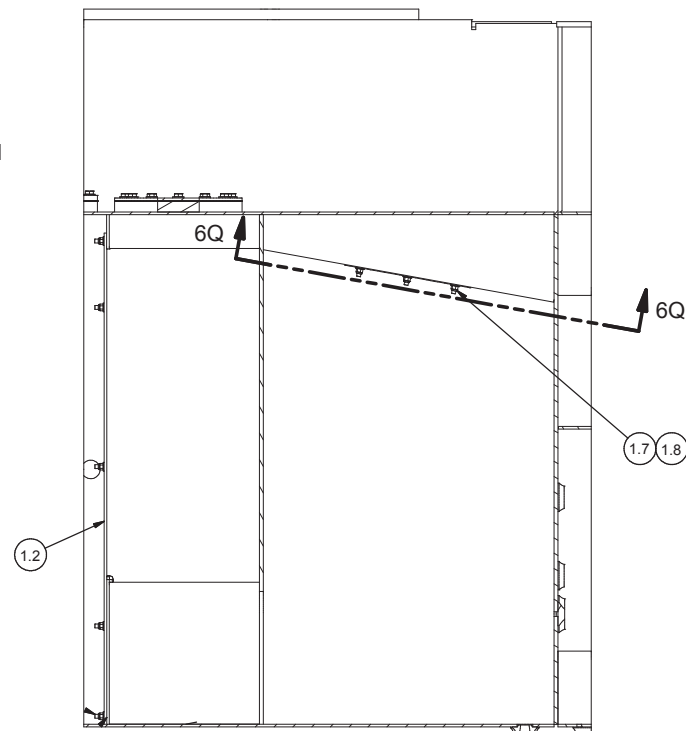
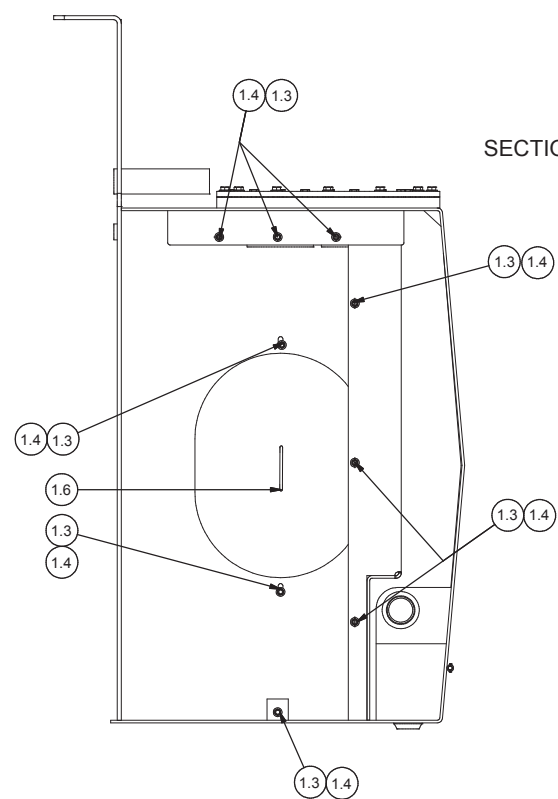
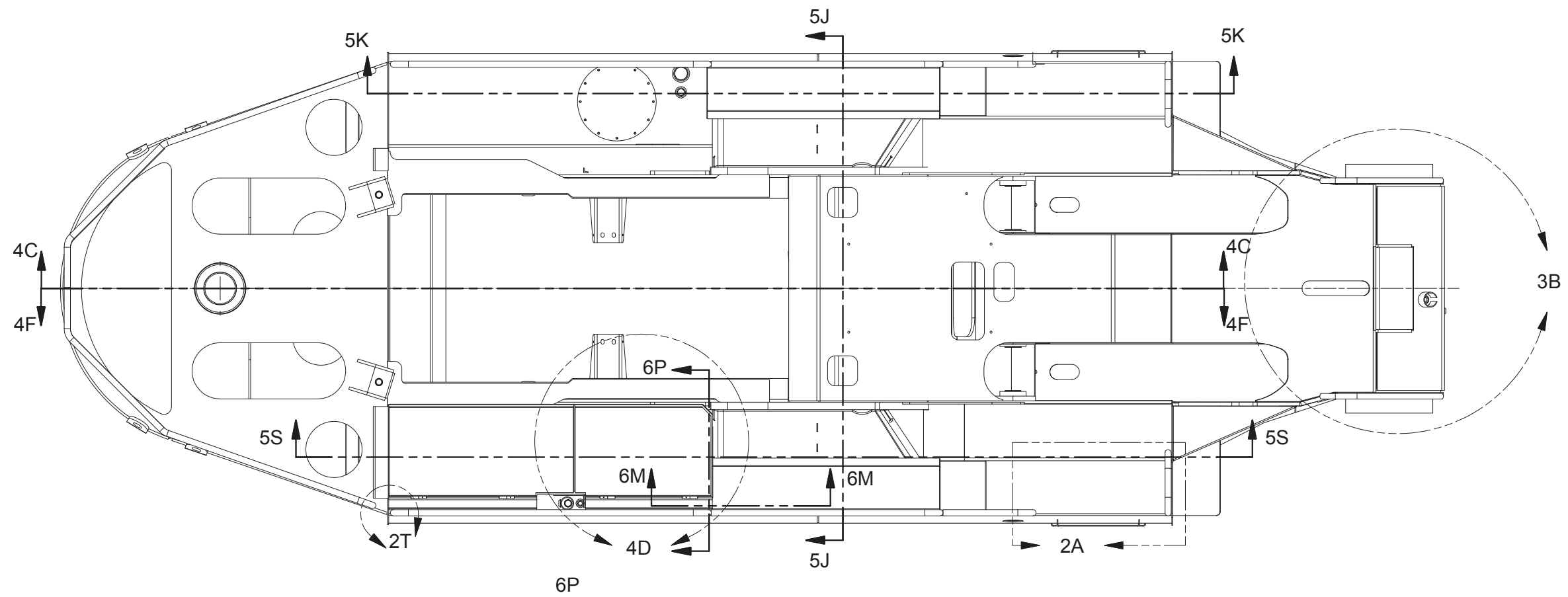

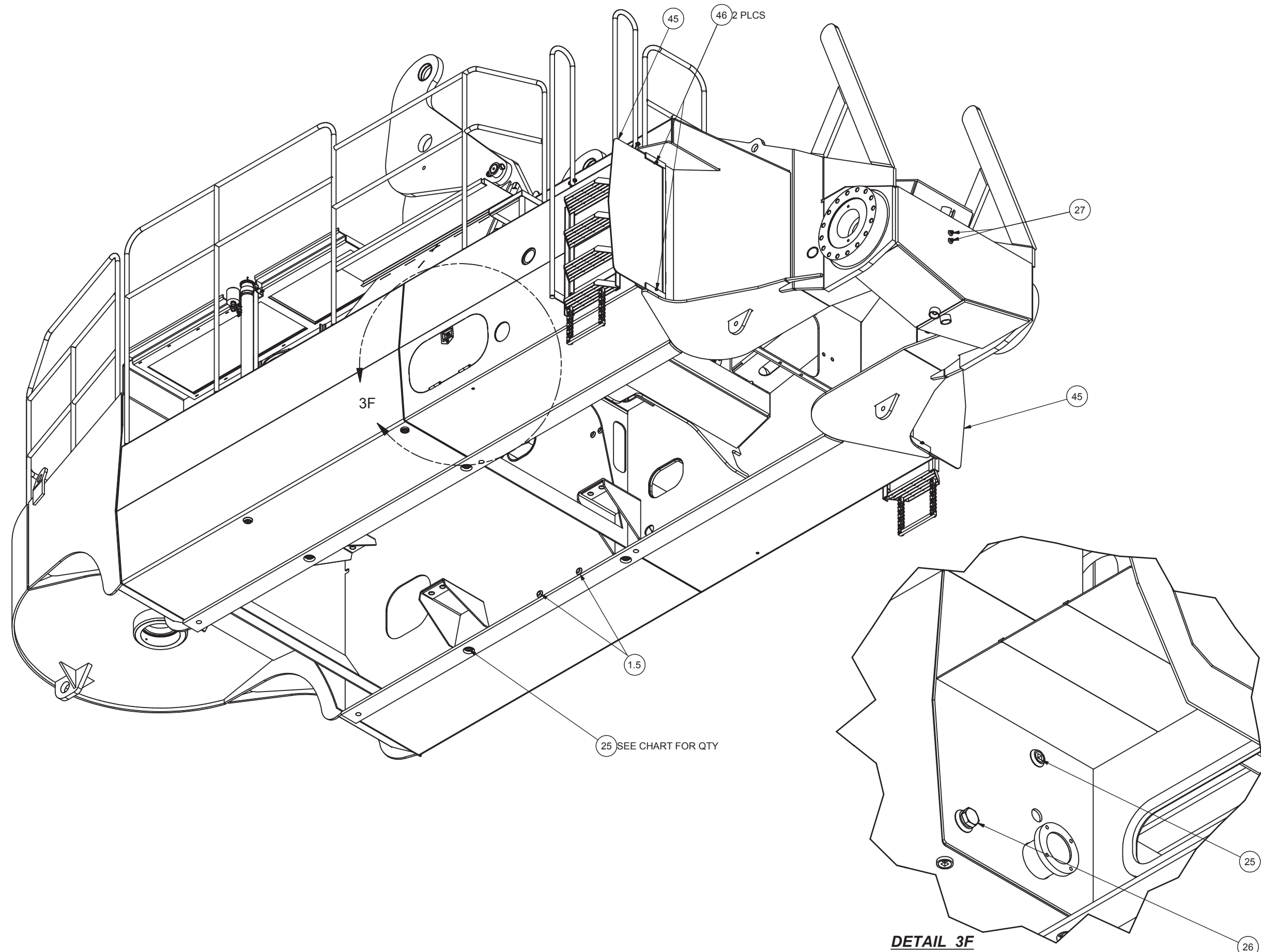

AD