

Air Cleaner Installation

Air Cleaner Installation

Item	Part No.	Qty	Description	Item	Part No.	Qty	Description
	588096		Air Cleaner Installation				
1	* 258700	2	. Air Cleaner Assembly	21	296418W	8	. Hard Washer
2	R1904878	3	. Elbow	22	R13811191	17	. Locknut
3	215733	2	. Elbow	23	221767W	34	. Washer
4	224226	2	. Elbow	24	16828W	18	. Capscrew
5	224354	1	. Elbow	25	208136	1	. Indicator
6	228425	2	. Elbow	26	208137	1	. Filter, Restriction
7	YDHA 8212-53.00	1	. Tube 7.00 X .060WI X 53.00	27	YDHA 8213-28.00	2	. Tube
8	YDHA 8212-13.88	1	. Tube 7.00 X .060WI X 13.88	28	588731	1	. Bracket, Support
9	YDHA 8213-10.00	2	. Tube 6.00 X .065WI X 10.00	29	R13803357	2	. T-Bolt Clamp
10	YDHA 8213-15.88	1	. Tube 6.00 X .065WI X 15.88	30	586836	2	. Bar, Brace
11	586503	1	. Plate, Support, LH Air Cleaner	31	508790	1	. Bracket Assembly
12	586504	1	. Plate, Support, RH Air Cleaner	32	209405	2	. Fitting
13	586506	1	. Plate, Mounting	33	240714	1	. Hose Assembly
14	586507	1	. Bracket	34	R13811225	2	. Capscrew
15	588730	1	. Bracket, Intake	35	296422W	2	. Hard Washer
16	586510	1	. Tube Weldment, Air Intake	36	N/A	2	. Nut
17	258792	4	. T-Bolt Clamp	37	588143	1	. Elbow
18	224199	7	. T-Bolt Clamp	38	NCC0003125	1	. Nut
19	259035	1	. T-Bolt Clamp	39	R13802914	1	. Washer
20	Y09C-M0820	8	. Capscrew	40	R13811014	1	. Capscrew
				41	207245	11	. Clamp
				42	202259	1	. Clamp

* See Separate Coverage

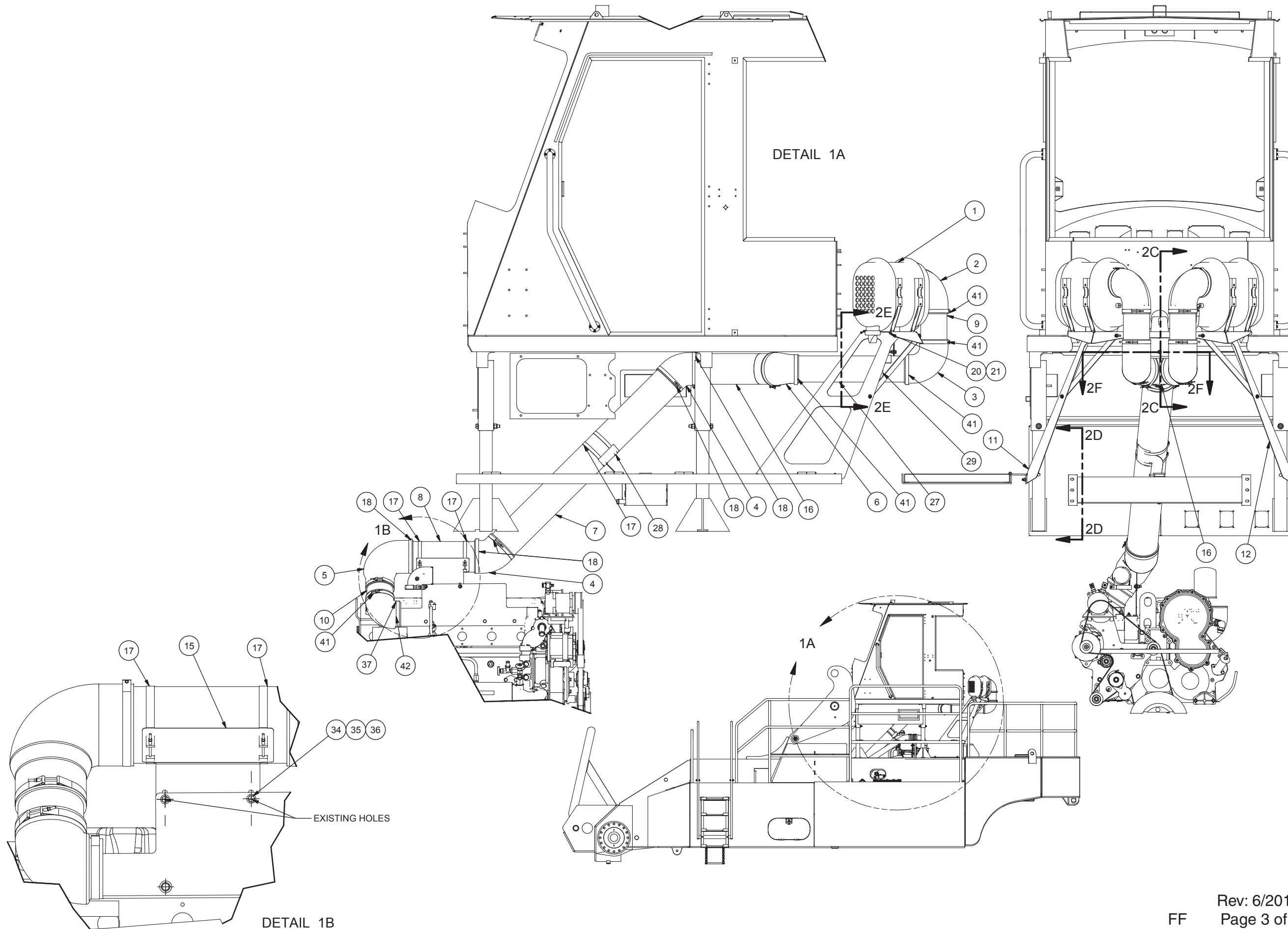
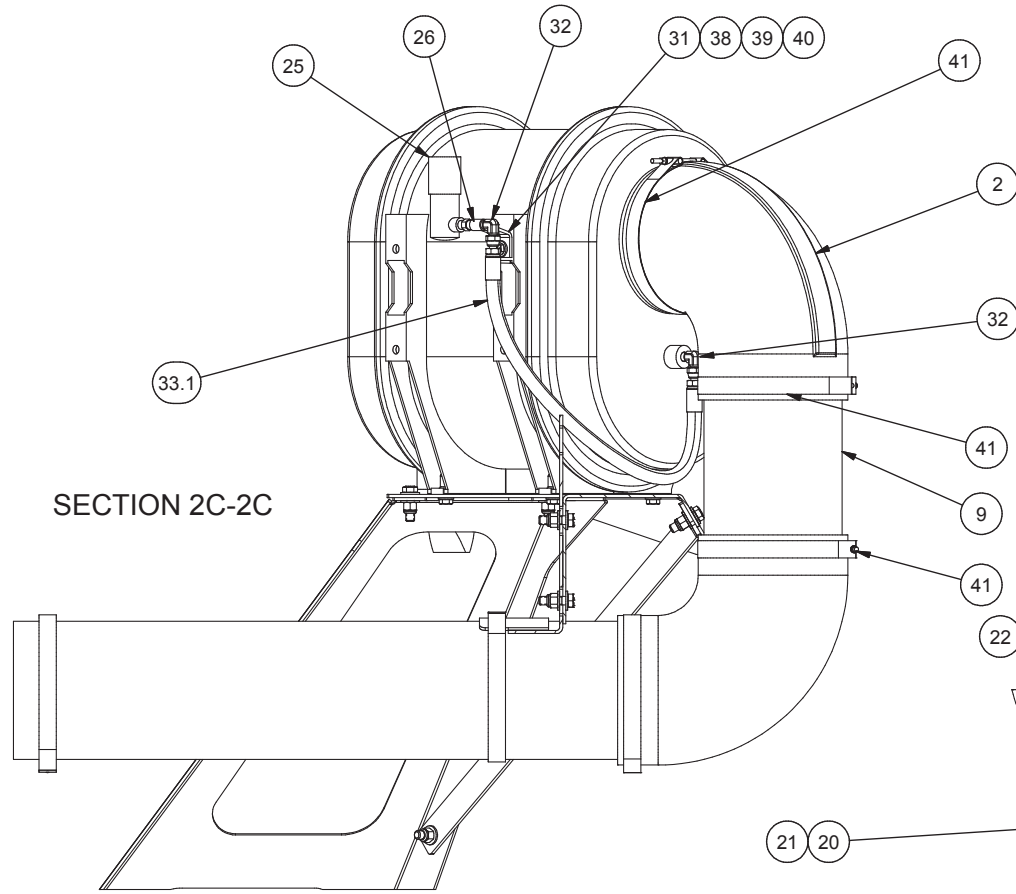



**SECTION 2D-2D
HOLE LOCATIONS**
SUGGESTED DIMENSION BOTH SIDES.
VERIFY CLEARANCE AND
DRILL AFTER CAB PLACEMENT

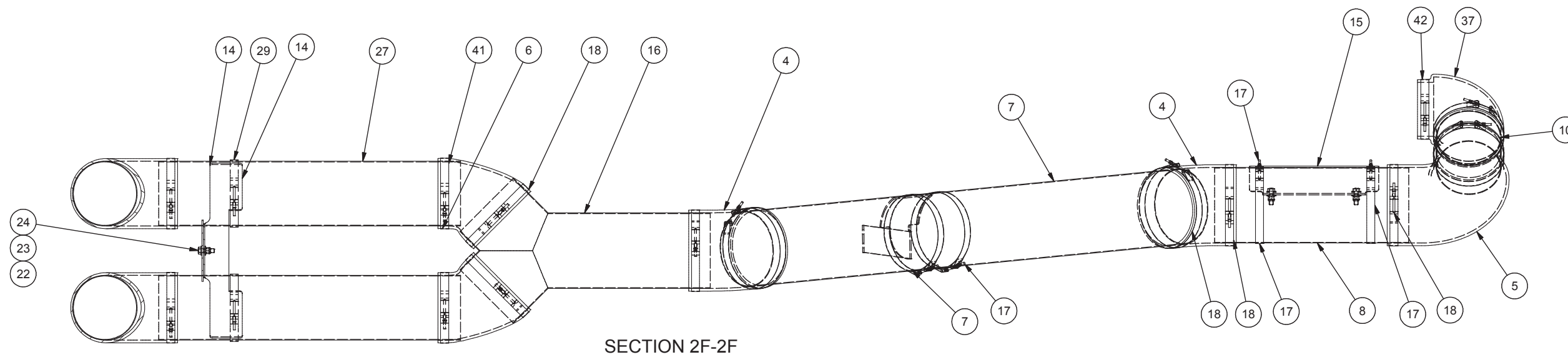
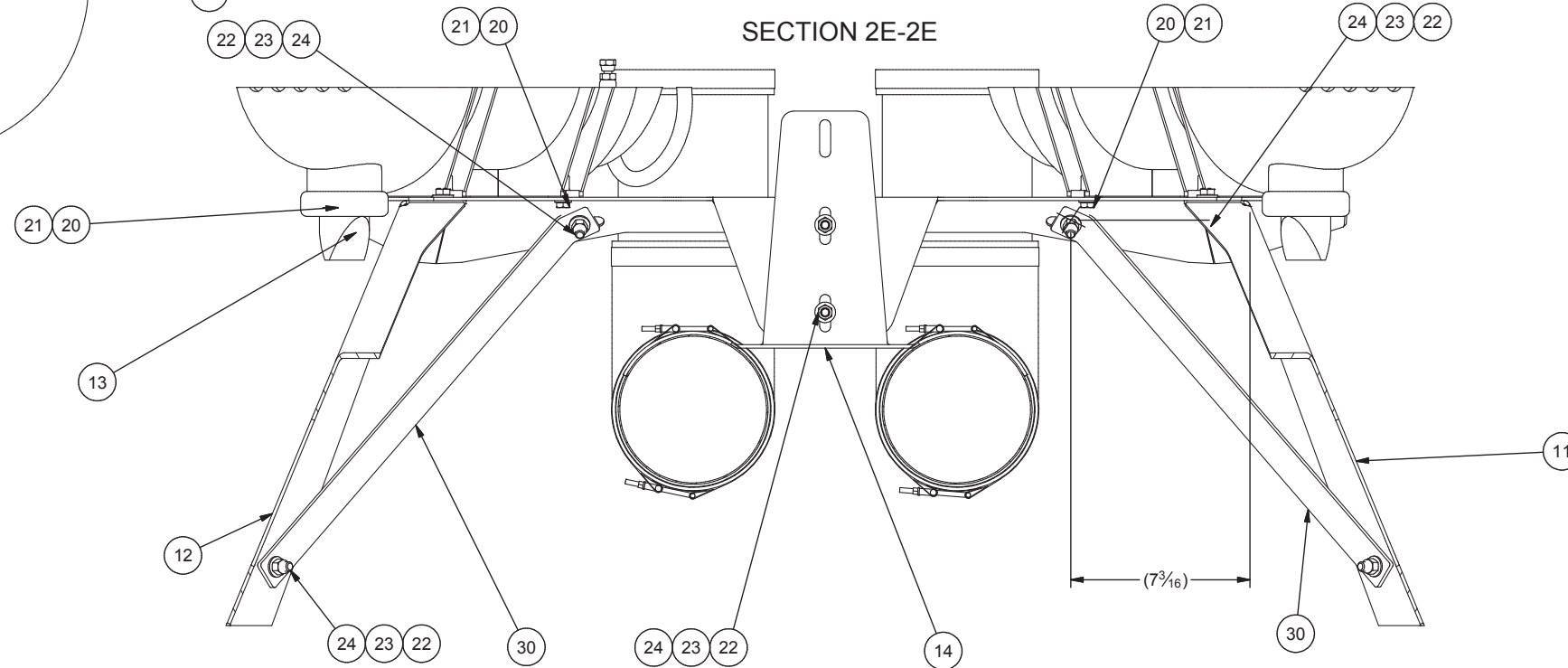
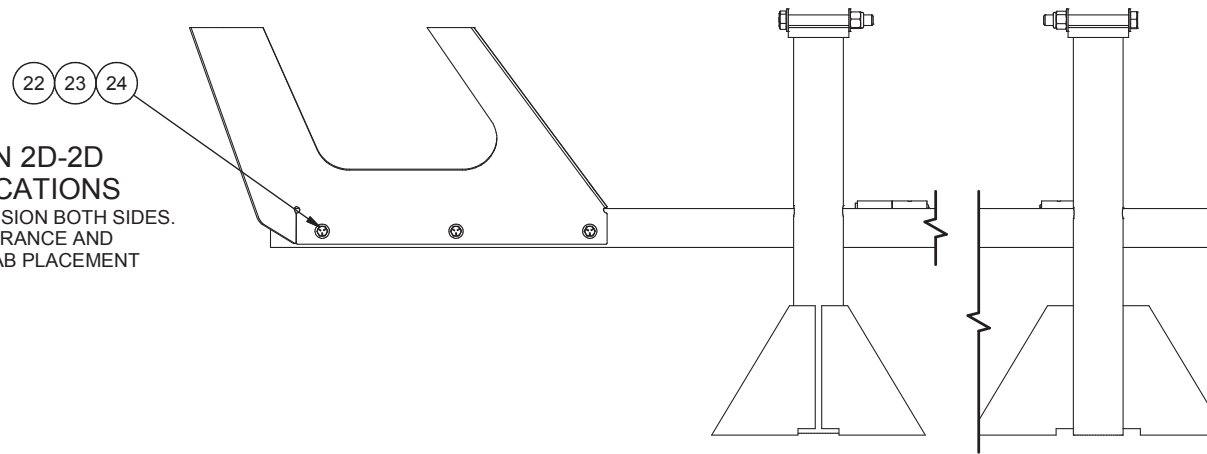

SECTION 2F-2F