

Decal, Location & Final Assembly Parts

Decal, Location & Final Assembly Parts

Item	Part No.	Qty	Description	Item	Part No.	Qty	Description
	588017		Decal, Location/Final Assy Parts				
2	576856	1	. Decal, Welding	53	578763	1	. Kit, Shipping/Bucket Frame
3	R10754	1	. Decal, Warning Batt Disconnect	55	247429	2	. Element
4	558098	1	. Name Plate	57	588744	2	. Element, Filter
5	557202	1	. Decal, Hydraulic Oil	58	588745	2	. Decal, Filter Element
6	576139	2	. Decal, Warning	59	200325	1	. Stop, Door
7	545430	4	. Decal, Warning No Clearance	60	587058	1	. Label, Implement Pump Inlet
8	547453	2	. Decal, No Riders	61	587059	1	. Label, Steering Pump Inlet
9	539197	1	. Decal, Fire Extinguisher	62	587060	1	. Label, Tilt Pump Inlet
10	539226	1	. Decal, Fire Ext	63	587061	1	. Label, Radiator Fan Pump Inlet
11	547451	2	. Decal, Do Not Approach	64	587062	1	. Label, Tilt Pump Pressure
12	529474	18'	. Decal, Racing Strip	65	587065	1	. Label, Rad Fan Pump Pressure
13	570517	2	. Decal, CHD-100	66	587066	1	. Label, Implement Pump Inlet
14	558506	4	. Decal, Wagner Med	67	587067	1	. Label, Implement Pump Inlet
16	557353	2	. Decal, Filter Pressure	68	587068	1	. Label, Brake Pump Pressure
17	557118	1	. Decal, Trans Oil Fill	69	587069	1	. Label, Implement Pump Inlet
18	528880	1	. Decal, Trans Oil	70	587070	1	. Label, Implement Pump Inlet
19	557201	1	. Decal, Diesel Fuel	71	587071	1	. Label, Pilot System Pressure
20	579532	1	. Decal, Filter Element	72	587072	1	. Label, Implement Pump Inlet
21	219382	1 ROLL	. Tape, Non-Skid	73	587073	1	. Label, Implement Pump Inlet
22	222737	2 TUBE	. Sealer, Edge	74	587090	1	. Label, Steering Filter
24	R10749	1	. Decal, Trans Oil Filter	75	587091	1	. Label, Main Filter
25	570048	1	. Decal, Windshield Washer Fluid	76	587092	1	. Label, Brake/Pilot Filter
26	587386	2	. Element, Filter	77	587093	1	. Label, Hyd Cool Fan Filter
28	221340	40 GAL	. Anti-Freeze	78	587094	1	. Label, Rad/Cad Fan Filter
29	236077	11 GAL	. Oil, Engine	79	587095	1	. Label, Implement Pump Inlet
30	219373	110 GAL	. Oil, Diesel Fuel	80	587096	1	. Label, Converter In Pressure
31	244281	A/R	. Lubricant, Gear	81	587097	1	. Label, Implement Pump Inlet
32	219374	7 Lb	. Oil, Grease	82	587098	1	. Label, Implement Pump Inlet
33	238206	305 GAL	. Oil, Hydraulic	83	587099	1	. Label, Strainer Out Pressure
34	246090	18 GAL	. Paint, W/R Yellow Primer	84	587100	1	. Label, Implement Pump Inlet
41	581855	1	. Decal, Warning Hood Support	85	587101	1	. Label, Implement Pump Inlet
42	557494	1	. Decal, Battery Disconnect	86	587102	1	. Label, Implement Pump Inlet
43	542919	3200 GAL	. Tire Ballast	87	587103	1	. Label, Return Filter
44	251334	2 GAL	. Paint, Flat Black	88	587104	1	. Label, Transmission Filter
46	563641	1	. Decal, Check Engine Oil	89	587105	1	. Label, Transmission Strainer
47	587607	2	. Decal, Filter Element	90	906581	1	. Decal, Emission Control Info
49	242997	13 GAL	. Paint, W/R Yellow Finish	91	242864	1	. Additive, Elf Lube (1 Gallon)
50	243000	2 GAL	. Paint, W/R White Alkyd Enamel	92	FD70000434	1	. Decal, Manufactured in USA
51	243458	2	. Element, Filter				

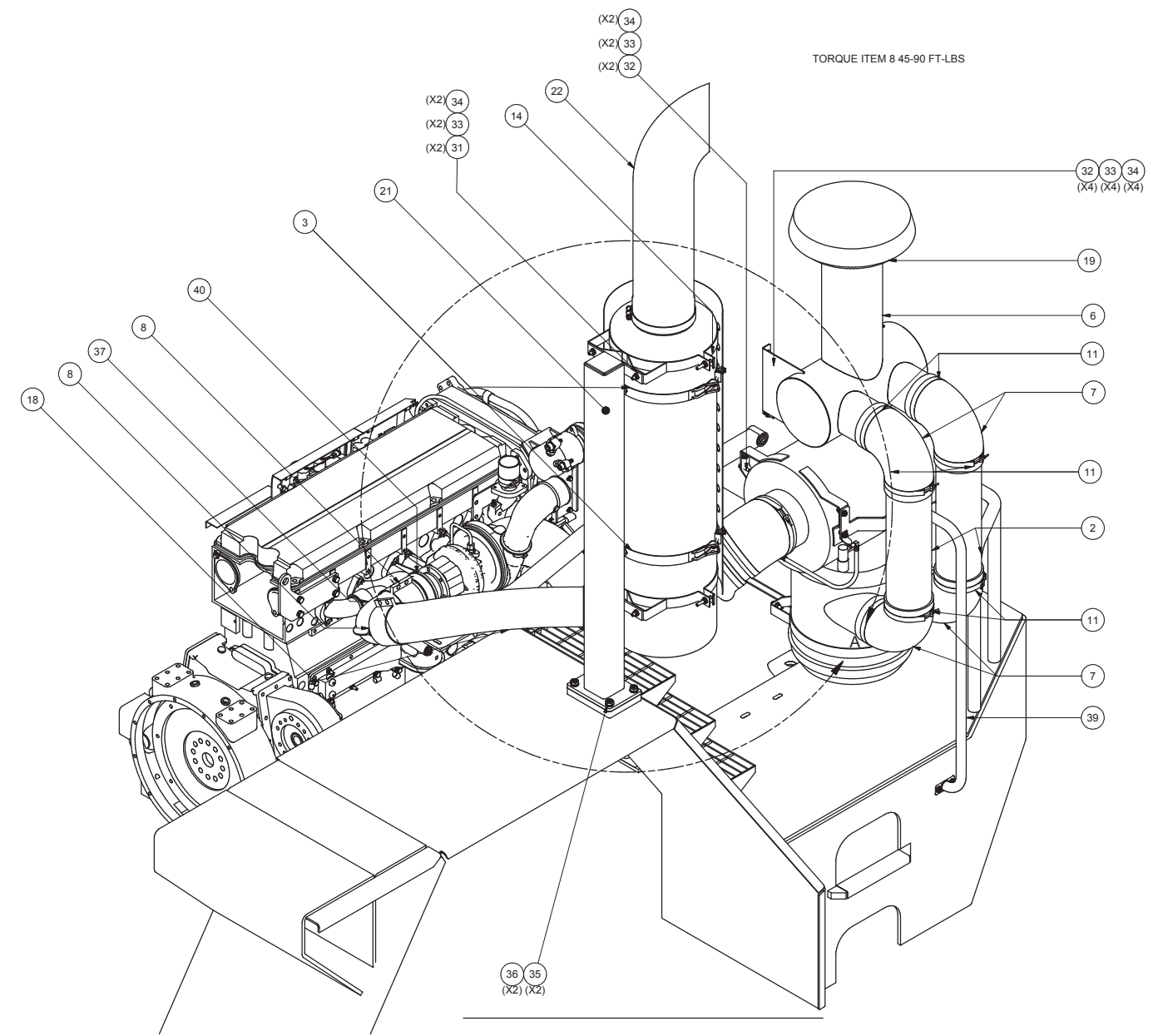

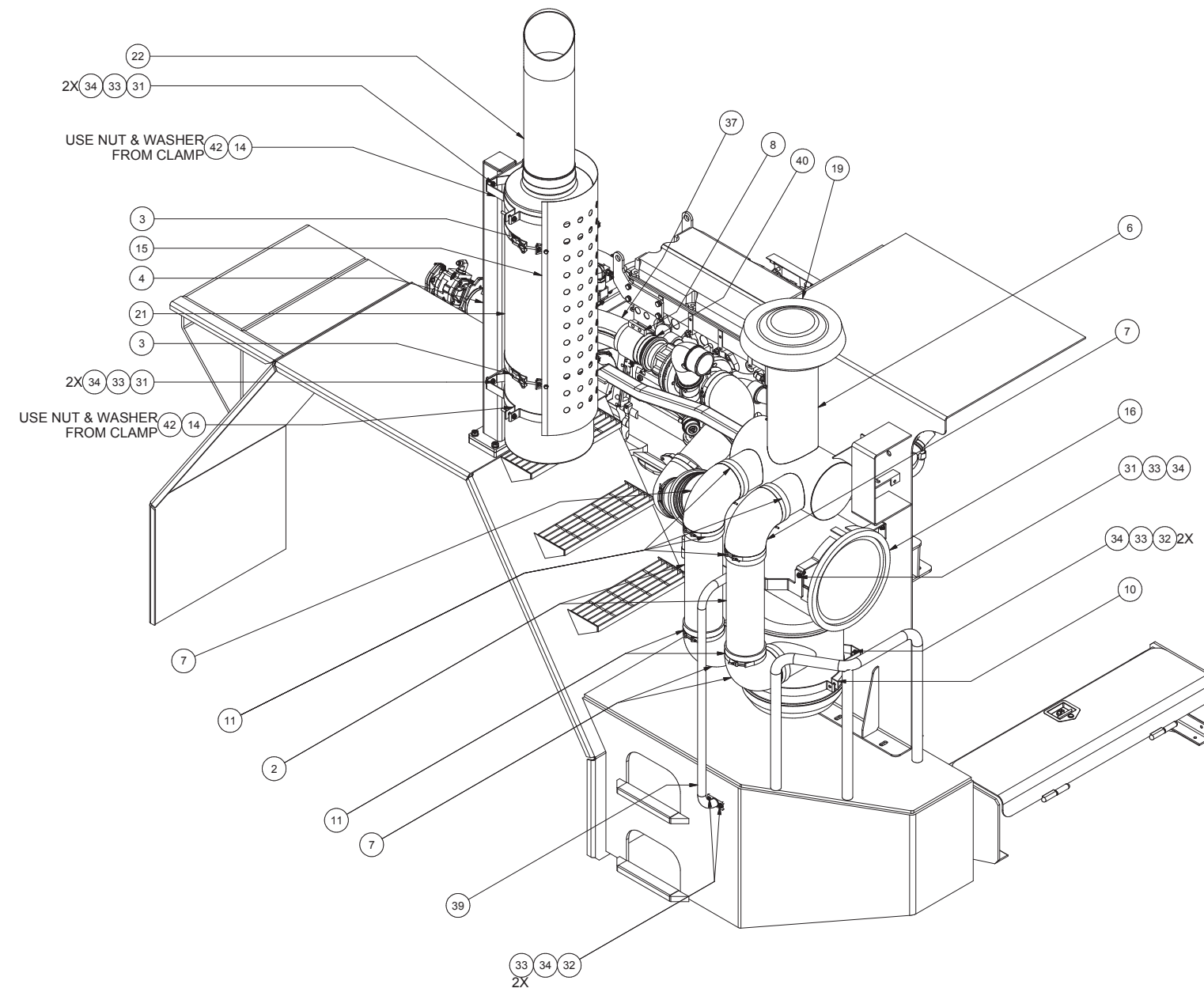
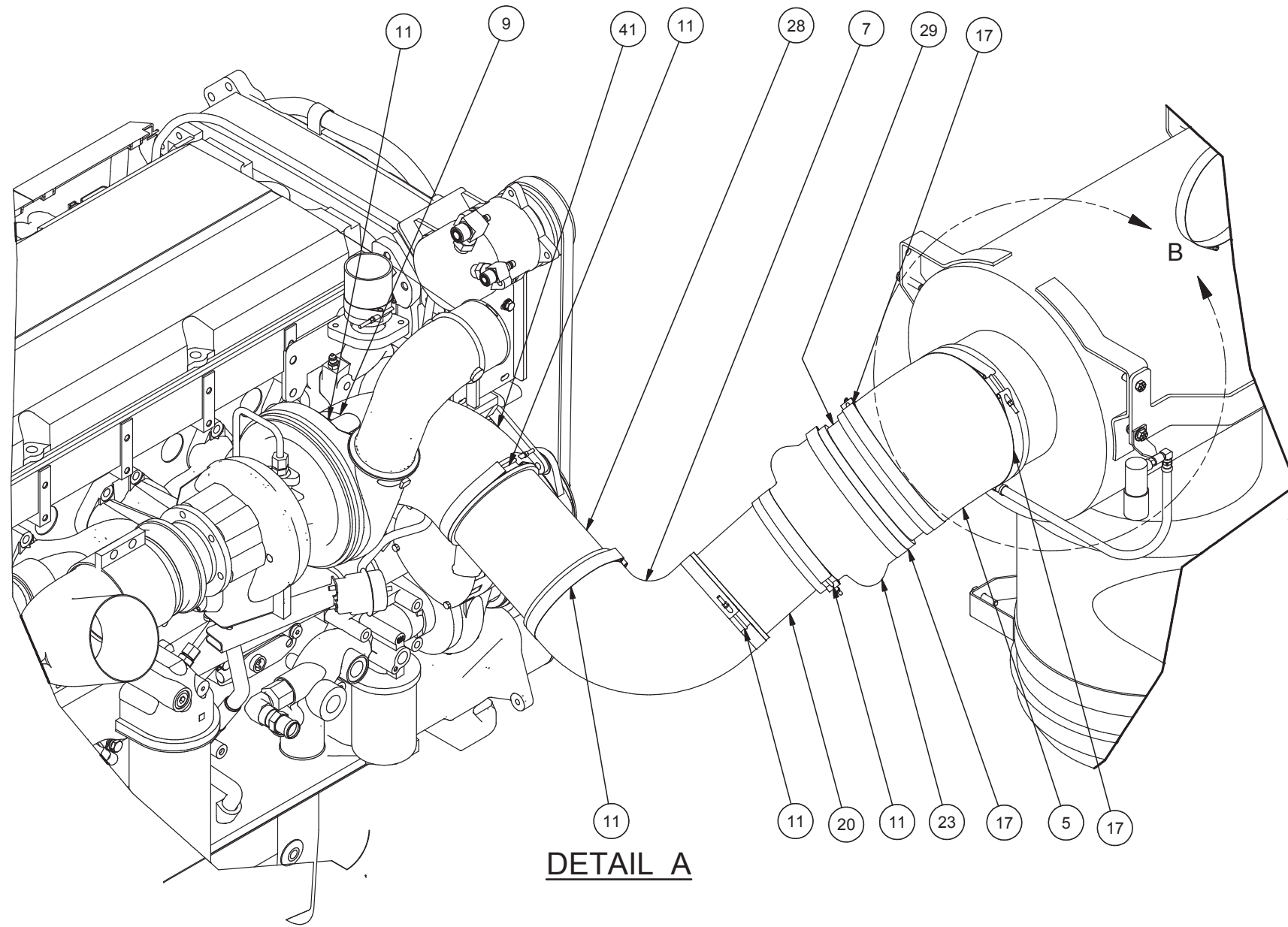

DETAIL A

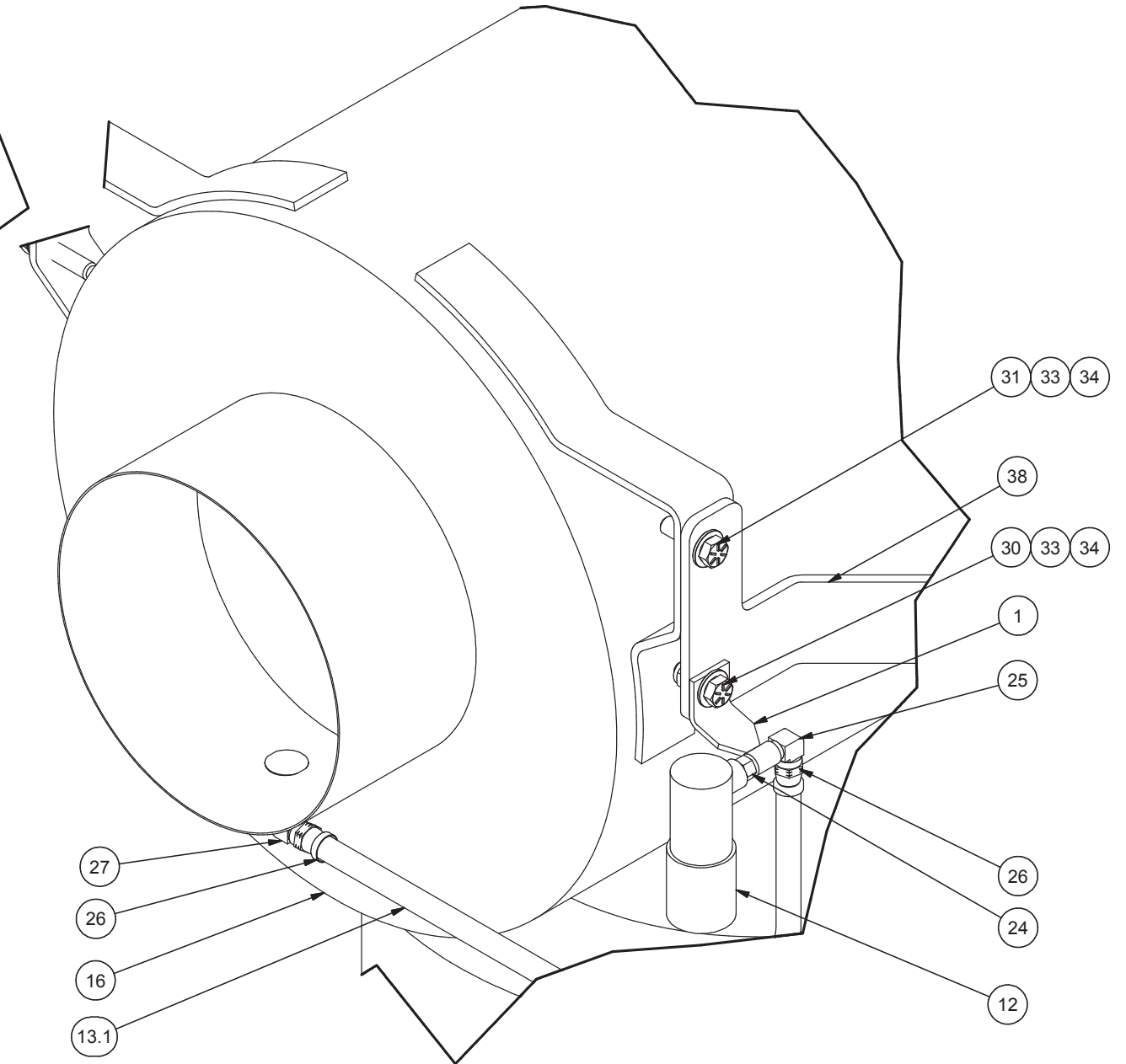

DETAIL B