

Valve Section

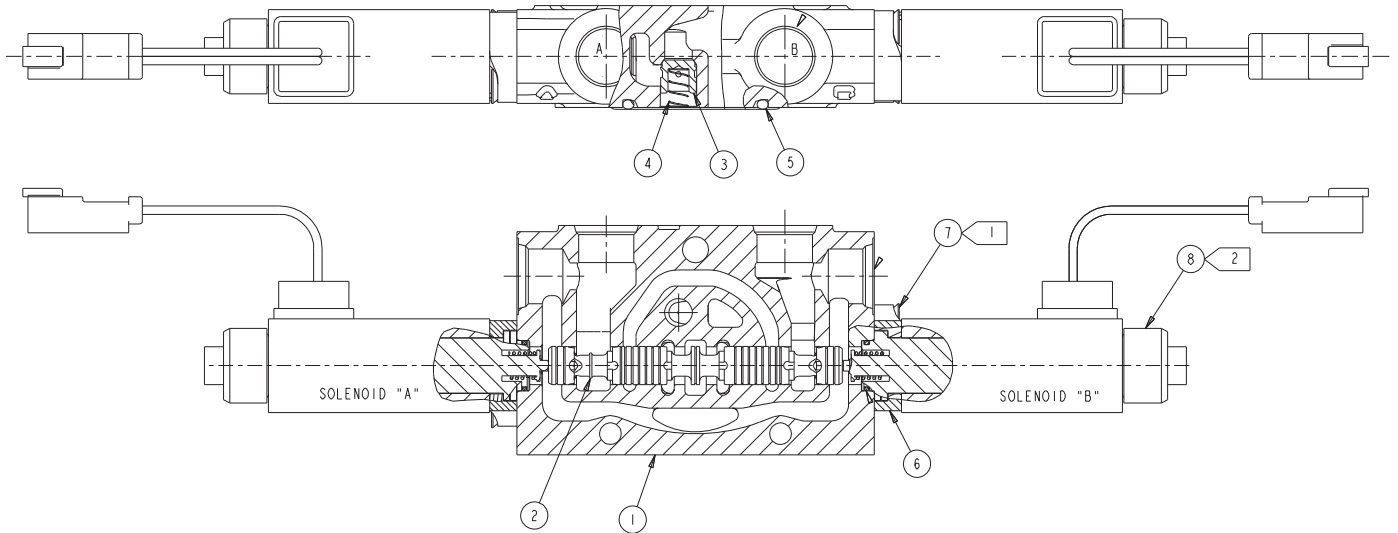

1	TORQUE 7 ft. lbs.
2	TORQUE 5 ft. lbs.

Item	Part No.	Qty	Description	Item	Part No.	Qty	Description
	<b>* 587418</b>		<b>Valve Section</b>				
1	587424	1	. Housing	6	587421	2	. Adapter
2	587423	1	. Spool	7	587420	4	. Capscrew
3	217854	1	. Poppet	8	587419	2	. Adapter
4	216887	1	. Spring				
5	207398	1	. O-Ring				

\* Use with quantity 1 of 587425 Connector Kit when replacing 229133 Valve Section