

Cab & Cowl Assembly

Cab & Cowl Assembly

Item	Part No.	Qty	Description	Item	Part No.	Qty	Description
	586156		Cab & Cowl Assembly				
1	586283	1	. Cab Weldment, Modular	53	586612	1	. Plate, LH Cover
2	* 586385	1	. Window Installation	54	586671	1	. Mounting Weldment, RH
3	258667	4	. Stud	66	* 586635	1	. Panel Assembly
4	586990	1	. Plate, Cover RH	67	586640	1	. Plate, RH Lwr Panel
5	258697	388"	. Gasket	68	586641	1	. Plate, LH Lwr Panel
6	258682	1	. Converter	69	586658	1	. Seat Weldment, Trainers
7	258712	2	. Pin, Striker	70	586650	1	. Panel Weldment, RH Front
8	258713	2	. Guard, Striker	71	586651	1	. Panel Weldment, RH Front
9	586991	1	. Plate, Cover LH	72	586597	1	. Cover Weldment
10	R10581	2	. Stud, Battery Feeder	73	258860	2	. Cam Latch Assembly
11	254962	1	. Connector, ECM	80	* 586811	1	. Panel Assembly, Alarm
12	587033	2	. Shaft, Stand-Off	81	257710	2	. Wire Harness, Powerview Jumper
13	256319	2	. Receptacle	83	586814	1	. Plate, Mounting
14	241826	8	. Receptacle, Wedglock	84	586815	2	. Plate, Vent
16	259262	4	. Jam Nut	87	BMP0093769	4	. Mount, Sandwich Single Stud
17	259263	8	. Machine Screw	88	258413	1	. Pad, Seat Back
18	259264	8	. Nut, Esna	89	258412	1	. Seat, Training
19	259265	8	. Machine Screw	90	R13811189	12	. Locknut
20	296413W	8	. Hard Washer	91	221763W	16	. Washer
21	587034	2	. Jam Nut	92	Y25G-0406	8	. Capscrew
22	258772	2	. Motor Assembly, Wiper	93	241059	17	. Insert
23	258773	2	. Arm Assembly, Wiper	94	R13809543	14	. Locknut
24	258774	2	. Blade Assembly, Wiper	95	Y09G-(1024)08	2	. Capscrew
25	258434	2	. Spacer	96	240983	14	. Insert
26	256320	1	. Light, Dome	97	Y25G-0408	5	. Capscrew
28	* 586437	1	. Panel Assembly, LH	98	R13801783	4	. Capscrew
29	* 586438	1	. Panel Assembly, RH	99	18699W	4	. Capscrew
30	* 586439	1	. Panel Assembly	100	223099	4	. Lockwasher
32	* 586398	1	. Door Assembly, RH	101	224120W	4	. Capscrew
33	* 586399	1	. Door Assembly, LH	102	R13812512	6	. Lockwasher
34	* 586469	1	. Console Assembly, Overhead	103	R13811034	38	. Capscrew
35	586558	3	. Hinge Assembly	104	201567	38	. Lockwasher
36	586560	3	. Hinge Assembly, LH	105	221767W	63	. Washer
37	586583	12	. Pad, Hinge	106	R13802914	23	. Hard Washer
38	18720W	12	. Capscrew	107	Y21C-0508	3	. Capscrew
39	R13810990	2	. Capscrew	108	Y21C-0616	17	. Capscrew
40	2301055W	10'	. Vinyl Protective Trim	109	Y21C-0516	20	. Capscrew
41	258919	2	. Housing, Bearing	110	R13811191	4	. Locknut
42	258920	2	. Lever, Clamp	111	221499W	4	. Capscrew
43	258921	4	. Washer, Thrust	112	258706	2	. Louver, Ball
44	258922	2	. Shaft, Flanged	113	232969	12	. Capscrew
45	258923	1	. Latch, LH Rotary	114	234197	4	. Flat Washer
46	258924	1	. Latch, RH Rotary	115	SMS0000217	4	. Hex Self Tapping Screw
47	258925	2	. Spring, Extension	116	00103338	12	. Flat Washer
48	258926	2	. Clevis	117	238437	4	. Nut, Esna
49	258928	2	. Stud	118	R13813167	4	. Machine Screw
50	586559	2	. Plate, Arm	119	Y25G-0414	8	. Capscrew
51	586561	1	. Mounting, LH	120	R13107	24	. Machine Screw
52	586673	1	. Plate, Rh Cover				

* See Separate Coverage

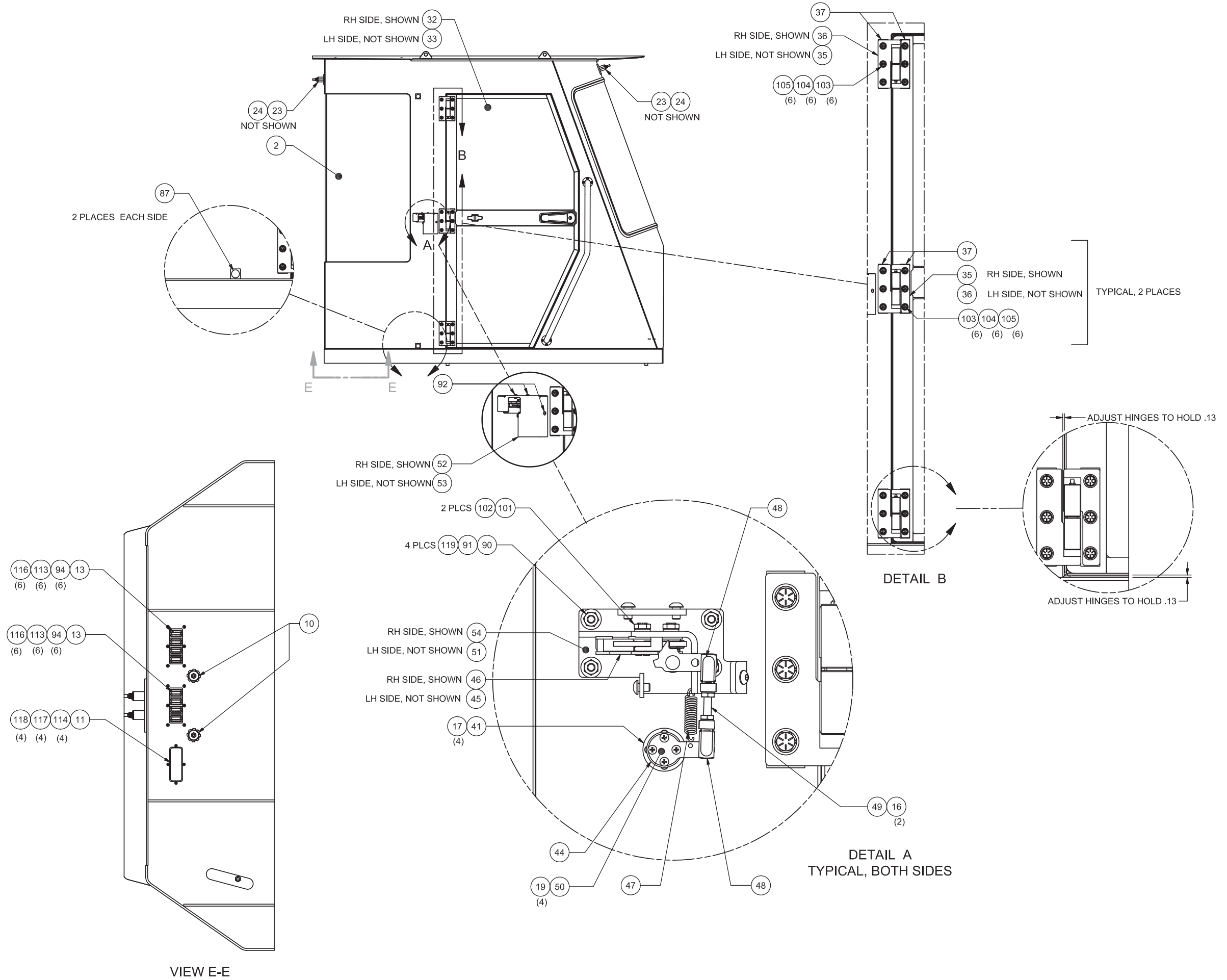
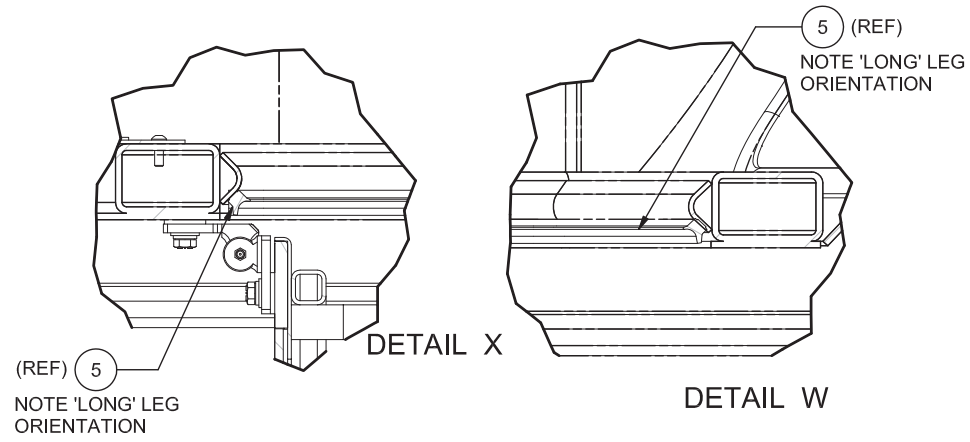



ITEM 5 IS INSTALLED AS A CONTINUOUS PIECE FROM THE BOTTOM TO THE TOP OF THE REAR DOOR PILLAR. MITRE CUT AT TOP TO CONNECT WITH FRONT PORTION OF SEAL;

ITEM 5 IS INSTALLED IN A CONTINUOUS PIECE FROM THE FLOOR SILL TO THE TOP OF THE REAR DOOR PILLAR. SEAL FOLLOWS COUNTOURS OF THE DOOR FRAME, WITH NO BREAKS. MITRE CUT TO CONNECT TO REAR PORTION OF SEAL;

