

Power Unit

Power Unit

Item	Part No.	Qty	Description	Item	Part No.	Qty	Description
	584388		Power Unit				
1	* 254937	1	. Engine	58	R13811082	3	. Capscrew
2	* 246855	1	. Radiator W/CAC	60	14857	1	. Fitting
3	* 239794	1	. Converter	61	11767	4	. Kit, Split Flange
4	570775	1	. Ring Gear Assembly		200604	4	.. Washer
	237315	96	.. Washer, Bellville		209537	2	.. Clamp Half
	237316	24	.. Nut		222379	4	.. Capscrew
	570735	1	.. Ring Gear	62	217657	1	. Fitting
	570776	24	.. Stud	63	14274	3	. Fitting
5	234183	1	. Alternator	64	210011	1	. Fitting
6	584774	1	. Bracket	65	210084	2	. Fitting
7	529449	1	. Wire Assembly, Ground	66	211693	1	. Fitting
8	581113	1	. Wire Harness	67	R12968265	1	. Cap, Radiator
9	581137	1	. Wire Harness	75	202947	2	. Hose Clamp
10	578953	1	. Wire Harness	76	243488	4	. Connector
11	578954	1	. Wire Harness	77	243489	8	. Clamp
12	255221	1	. Fitting	78	580509	1	. Tube
13	246987	1	. Fan	79	211791	5'	. Hose, Radiator
14	247024	1	. Pulley, Alternator	80	232881	8	. T-Bolt Clamp
15	580587	1	. Air Scoop	81	579333	1	. Tube, Lower Rad.
16	* 245289	1	. Pump, Tandem	82	580389	1	. Tube, Alum.
17	* 245520	1	. Pump, Hydraulic	83	580390	1	. Tube, Alum.
18	539968	2	. Sleeve, Pump	84	580504	2	. Engine Mount, Rear
19	245704	2	. Fitting	87	Y17C-1032	6	. Capscrew
20	12721	2	. Kit, Split Flange	91	219383	8'	. Wire
	200604	4	.. Washer	92	219392	7'	. Loom, Auto
	209538	2	.. Clamp Half	93	209578	8	. Clamp
	222379	4	.. Capscrew	96	236805	10	. Capscrew
21	505499	3	. Gasket	97	R13801005	10	. Lockwasher
23	206320	6'	. Hose, Bulk	98	224120W	2	. Capscrew
24	247072	2	. Fitting	99	223871	2	. Lockwasher
25	580421	1	. Engine Mount	100	219404	2'	. Wire
26	221657W	2	. Capscrew	101	228776	3	. Terminal Ring
27	R13811457	4	. Flat Washer	102	203341	1	. Terminal Ring
28	224194	2	. Nut, Esna	104	200247	3	. Terminal Ring
29	200454W	12	. Capscrew	105	219435	2'	. Wire
30	R13811451	8	. Flat Washer	106	219408	1'	. Wire
31	R13812516	20	. Lockwasher	107	229301	1	. Relay
32	Y17C-1028	6	. Capscrew	111	23390	1	. Kit, Split Flange
33	R13042	10	. Flat Washer		200604	4	.. Washer
34	R13809066	16	. Lockwasher		201621	4	.. Capscrew
35	203274	2	. Shutoff Valve		203523	1	.. O-Ring
36	12930006	2	. Fitting		209539	2	.. Clamp Half
37	Y17C-0624	4	. Capscrew	115	220095	1	. Fitting
38	R13806980	4	. Flat Washer	117	223436	1	. Fitting
39	R13802575	4	. Lockwasher	118	248624	1	. Fitting
40	249309	1	. Compressor	119	580395	1	. Angle, LH
43	R13801909	1	. Capscrew	120	580396	1	. Angle, RH
44	223587	1	. Nut, Esna	121	209752	1	. Fitting
45	221560W	1	. Capscrew	129	209406	4	. Fitting
46	209420	1	. Fitting	131	* 248990	1	. Pump
47	162572W	8	. Capscrew	132	226184	1	. Gasket
48	293646W	4	. Capscrew	133	579242	2	. Bracket
49	233477	4	. Lockwasher	134	579325	2	. Lifting Eye
50	R13812665	4	. Hard Washer	135	* 580644	1	. Engine Oil Fill
51	00120396	14	. Flat Washer	136	* 580976	1	. Dipstick & Housing Assembly
52	209805	1	. Fitting	140	234497	8	. Vibration Dampener
53	209490	1	. Fitting	141	578361	8	. Flat Washer
54	223794	1	. Fitting	142	221666W	8	. Capscrew
55	221186	1	. Fitting	143	00106268	16	. Flat Washer
56	203528	1	. O-Ring	144	223188	8	. Locknut
57	200454W	6	. Capscrew				

* See Separate Coverage

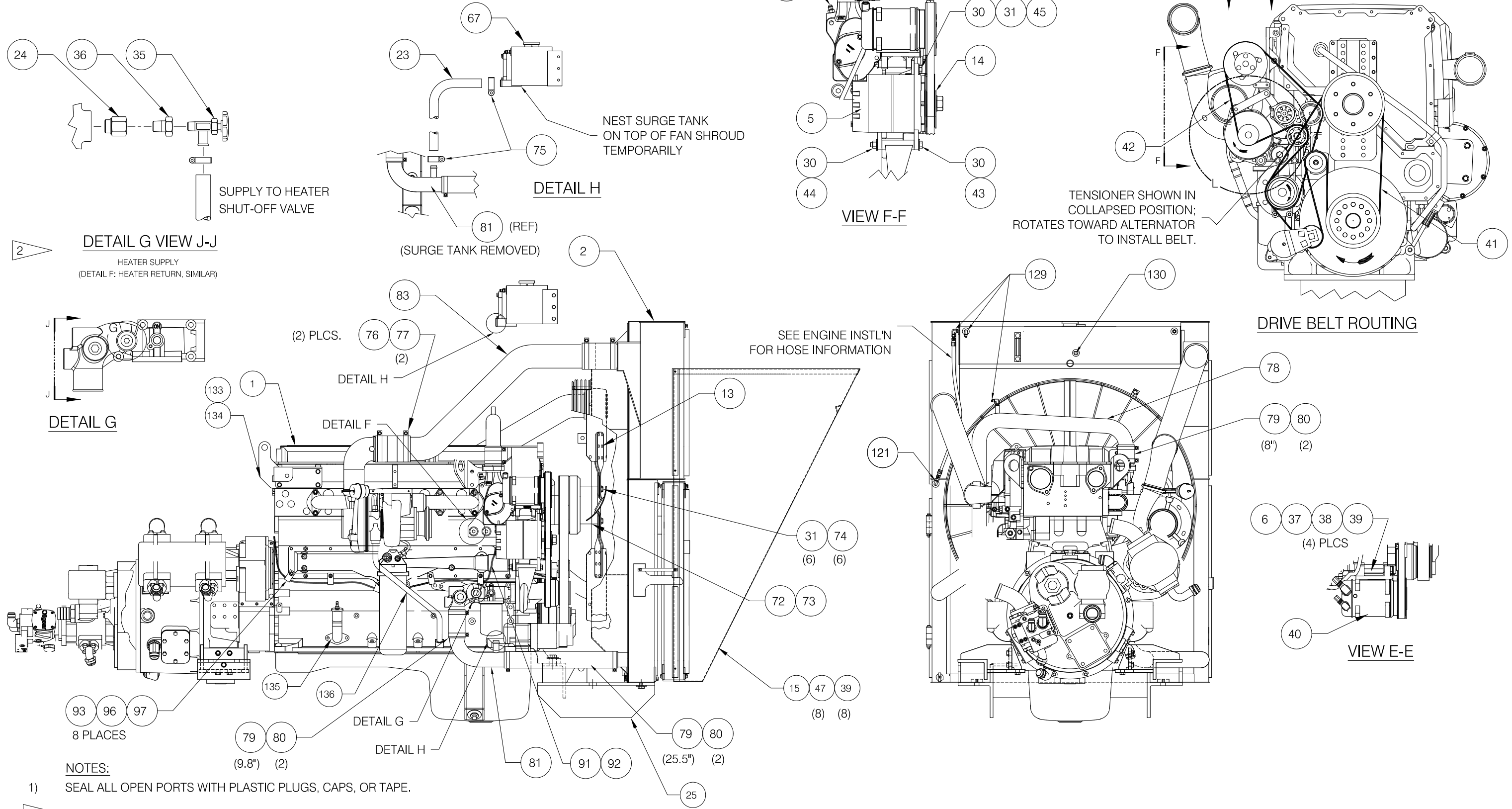

DETAIL G VIEW J-J
HEATER SUPPLY
(DETAIL F: HEATER RETURN, SIMILAR)

DETAIL H
NEST SURGE TANK
ON TOP OF FAN SHROUD
TEMPORARILY
(SURGE TANK REMOVED)

VIEW F-F

TENSIONER SHOWN IN
COLLAPSED POSITION;
ROTATES TOWARD ALTERNATOR
TO INSTALL BELT.

DRIVE BELT ROUTING

VIEW E-E

NOTES:

- 1) SEAL ALL OPEN PORTS WITH PLASTIC PLUGS, CAPS, OR TAPE.
- 2) REFER TO THE UNIT MASTER SHEET FOR THE CAB HEATER/AIR CONDITIONER PARTS LIST FOR CONTINUATION OF PLUMBING.
- 3) **CAUTION:** NO LINES OTHER THAN THE VENT LINES ARE TO BE PLUMBED TO THE TOP TANK OR ENGINE VENT PORTS. THESE LINES ARE NOT TO RISE ABOVE THE RADIATOR VENT PORTS OR HAVE ANY LOOPS THAT COULD TRAP AIR.
- 4) INSTALL PUMP (ITEM 15) WITH CASE DRAIN ORIENTED UP
- 5) FOR CLARITY, SUPPORTS, FITTINGS AND CONNECTIONS ARE NOT SHOWN IN ALL VIEWS;

