

---

Battery Box Installation

## Battery Box Installation

| Item                                   | Part No. | Qty | Description          | Item | Part No.  | Qty | Description                  |
|--|----------|-----|----------------------|------|-----------|-----|------------------------------|
| <b>582455 Battery Box Installation</b> |          |     |                      |      |           |     |                              |
| 1                                      | 18513W   | 2   | . Capscrew           | 8    | 523907    | 1   | . Battery Tray Assembly      |
| 2                                      | 16597W   | 2   | . Capscrew           | 9    | 523925    | 2   | . Shaft                      |
| 3                                      | 203055   | 4   | . Set Collar         | 10   | 523957    | 1   | . Pad                        |
| 4                                      | 223427   | 2   | . Flat Washer        | 11   | 523958    | 1   | . Skid                       |
| 5                                      | 519830   | 2   | . Bar, J-Bolt        | 12   | 579300    | 1   | . Holddown Weldment, Battery |
| 6                                      | 523870   | 4   | . Cap Assembly, Tray | 13   | R13802621 | 2   | . Flat Washer                |
| 7                                      | 523886   | 2   | . Rod                | 14   | R13804124 | 4   | . Locknut                    |

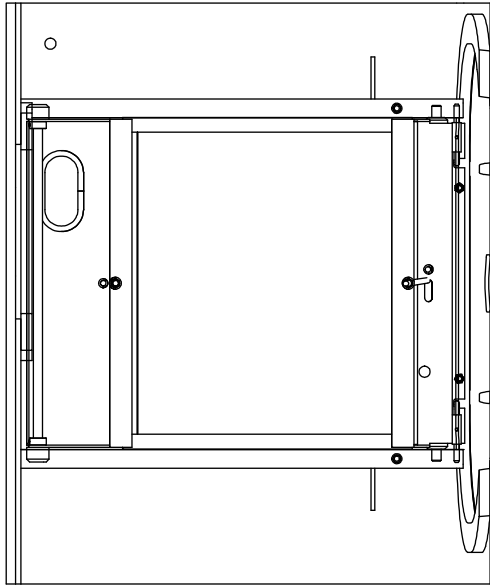

**SECTION B-B**

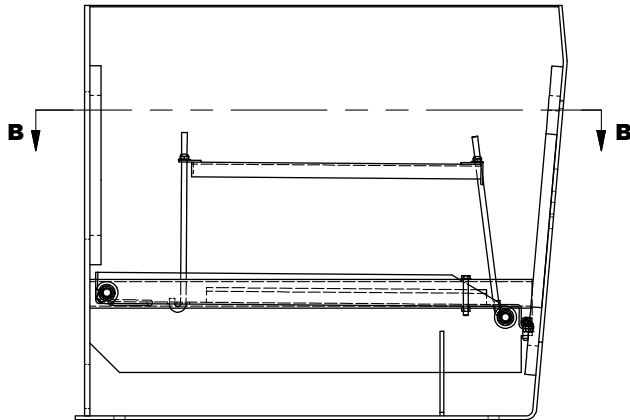

**SECTION A-A**

