Cowl Assembly

Cowl Assembly

Item	Part No.	Qty	Description	Item	Part No.	Qty	Description
	582010		Cowl Assembly				
1	579911	1	. Cowl Weldment	45	243472	2	. Symbol, Switch
3	* 578955	1	. Instrument Panel Assembly	46	234736	2	. Switch, 24V
4	* 578611	1	. Floor Mat Installation		234508	1	. . Socket
5	223654	4	. Locknut		236901	1	. . . Bulb
6	230282	6	. Flat Washer	47	R15512	1	. Symbol, Ether Start
7	235038	3'	. Weatherstrip	50	* 582012	1	. Sub-Panel Assembly, Relay
8	* 579408	1	. Column, Steering	51	234264	1	. Control Unit
9	244506	1	. Steering Wheel	52	571461	1	. Decal
10	R13656	1	. Switch, 24V	53	571430	1	. Decal
11	234651	1	. Button, Horn	54	225649	1	. Light, Reducer Panel
12	575038	1	. Mounting Plate	55	* 579853	1	. Panel Assembly, Door
13	201634	2	. Capscrew	56	241761	4	. End Stop
14	231931	2	. Capscrew	57	236485	1	. Frame, Mounting
15	236502	2	. Pilot Lamp	58	579854	1	. Wire Harness
16	00181354	4	. Capscrew	59	237495	1	. Symbol, Out-Of-Gear
17	201570	4	. Spring Washer	60	*a 234509	3	. Cover, Blank
18	224222	4	. Vibration Dampener	61	579855	1	. Wiring, Console
19	230096	4	. Capscrew	62	580119	1	. Decal
20	00106268	8	. Flat Washer	63	R840286	2	. Louver
21	223188	4	. Locknut	64	251346	2	. Hose Assembly
22	236503	1	. Lens, Reducer	65	* 243342	1	. Pedal Assembly, Elec Throttle
23	219517	1	. Connector, Cord	68	* 245672	1	. Controller, Elec/Mech Shift
24	237346	1	. Lens, Yellow	69	231337	2	. Hose Assembly
25	234495	8	. Capscrew	70	23577	3	. Fitting
26	227374	4	. Connector, Cord	71	233001	1	. Hose Assembly
27	226049	2	. Connector, Cord	72	* 252512	1	. Steering Unit
28	578958	1	. Wire Harness, Lower Console	73	234209	1	. Check Valve
29	227023	1	. Knockout Plate	74	209486	1	. Fitting
30	223759	2	. Connector, Cord	75	578588	1	. Angle
31	223645	4	. Nut, Esna	76	234177	8	. Capscrew
32	00103338	8	. Flat Washer	77	00103319	8	. Lockwasher
33	236488	2	. Switch, On/Off/On	78	240142	2	. Capscrew
34	22628	2 m	. Rail, Din	79	579856	1	. Wire Harness, Throttle
35	232969	4	. Capscrew	80	574813	1	. Plate, Cover
36	236924	87	. Terminal Block	81	236504	1	. Lens, Green
37	236925	3	. End Plate	82	234757	2	. Capscrew
38	236926	24	. Jumper, Horizontal	83	R13811189	2	. Locknut
39	R10547	1	. Buzzer	84	568288	1	. Mounting Plate
40	207155	1	. Switch, Ignition W/Keys	85	* 582011	1	. Junction Box Assembly
41	505158	1	. Decal	87	234740	1	. Frame, Mounting
42	234739	1	. Dimmer Switch, 17W	88	580120	1	. Decal
43	578489	1	. Plate	89	576690	1	. Decal
44	578506	1	. Plate	90	546943	1	. Decal

* See Separate Coverage

*a Machines with Bucket Detent shipped without these parts

3 HOSE COLOR CODE CHART

VALVE PORT	HOSE COLOR CODE	ITEM NO.
P	YELLOW	69
T	BLUE	64
R	GREEN	69
L	GRAY	64
LS	-	71

STEERING MODULE PORT LOCATIONS

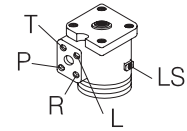

ROUTE FLAT AGAINST CAB BOTTOM OVER HINGE.

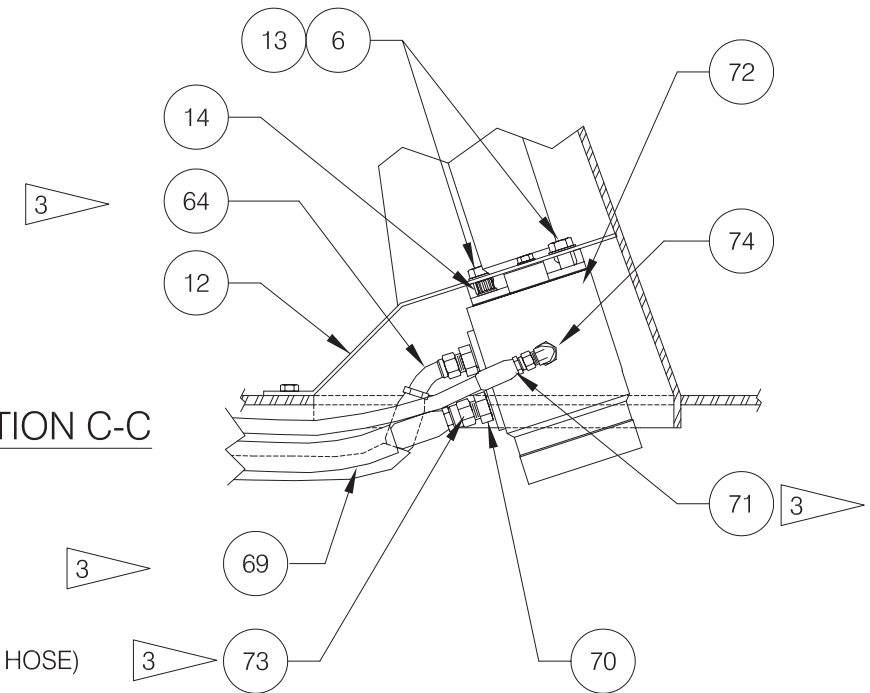
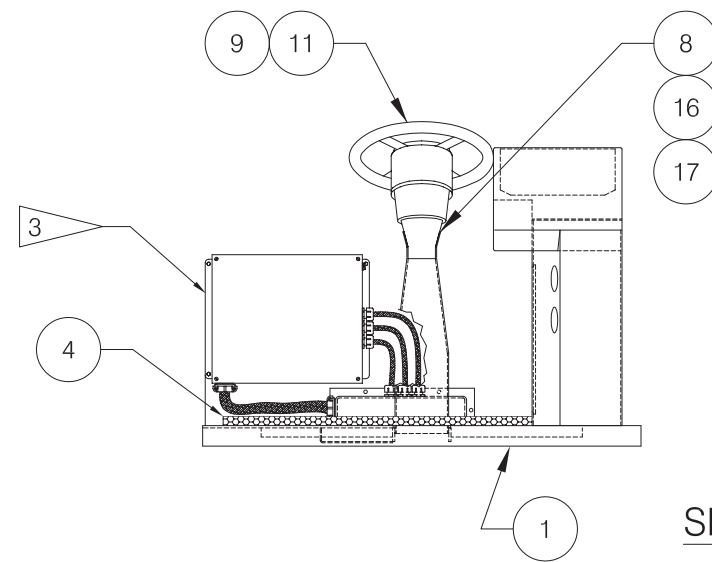
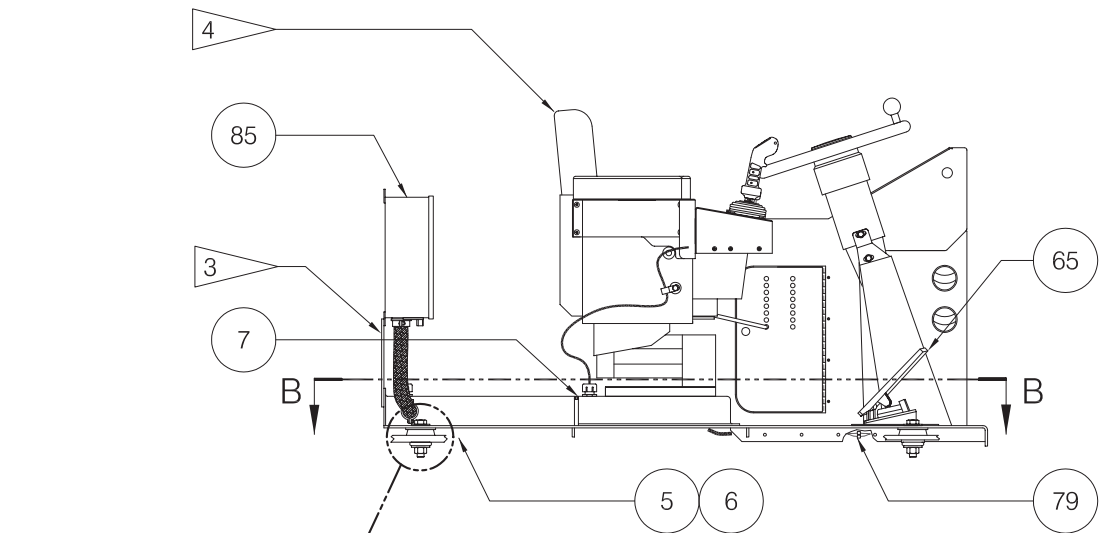
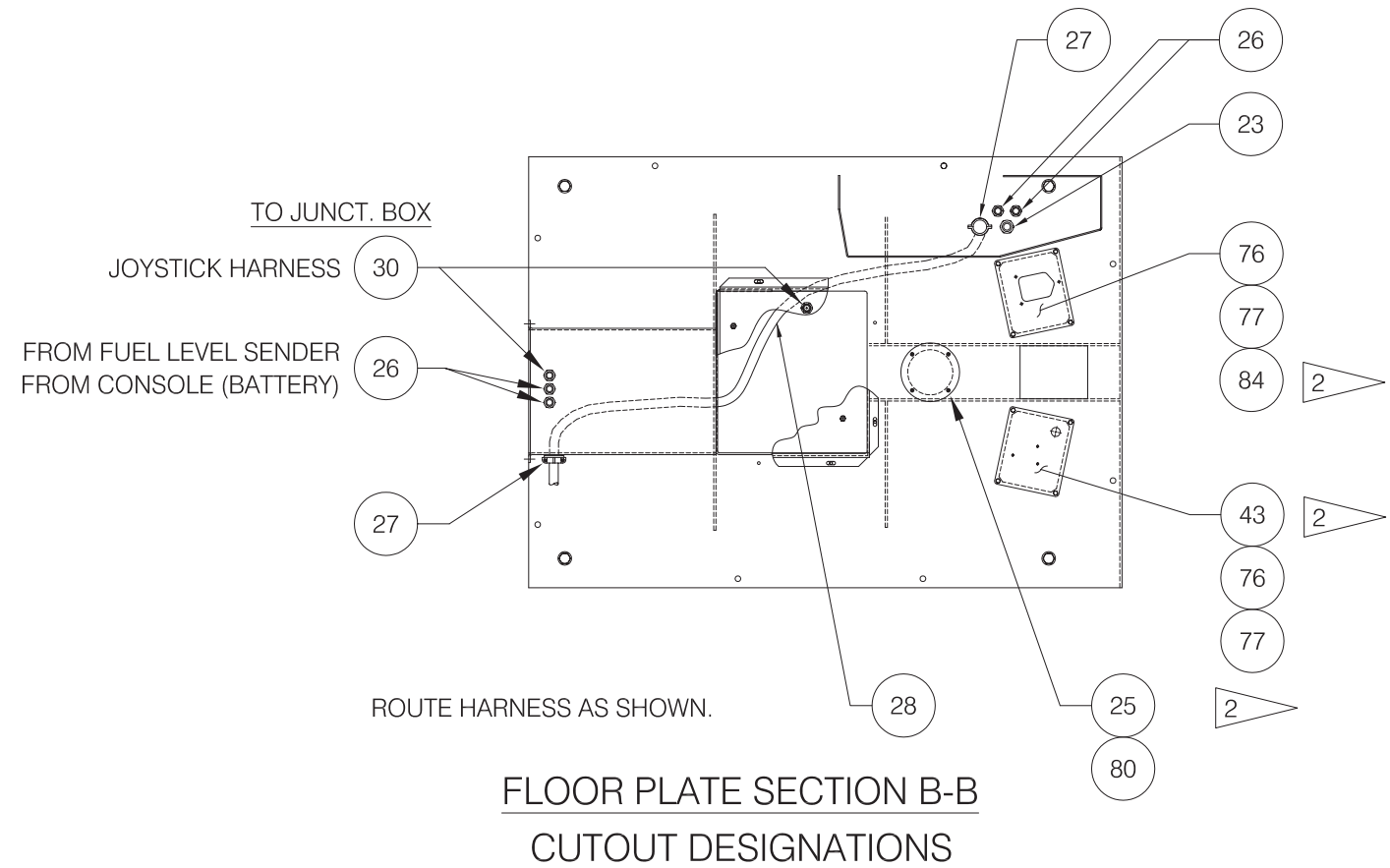
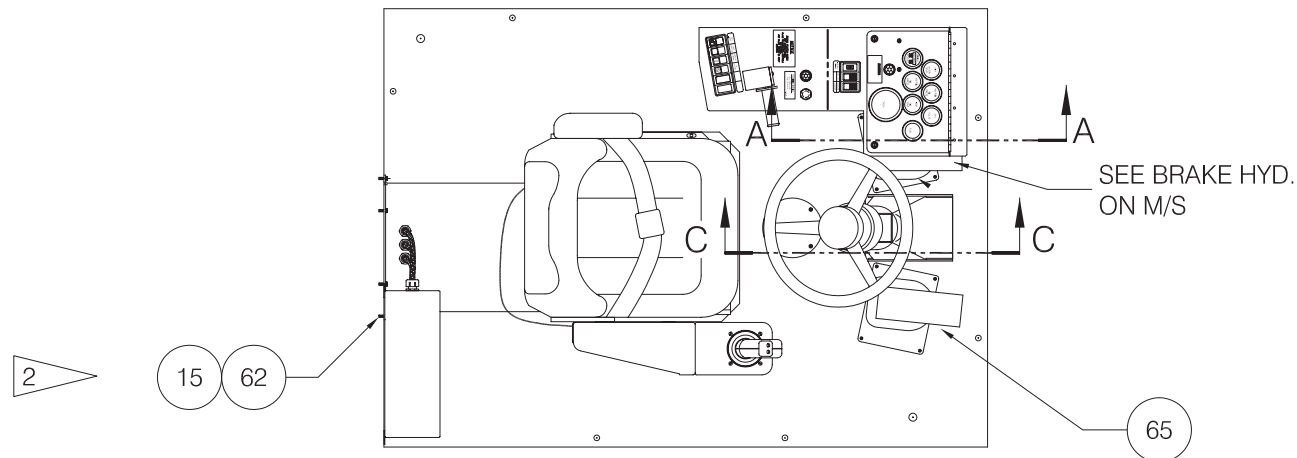

DETAIL A
TYP. (4) PLCS.

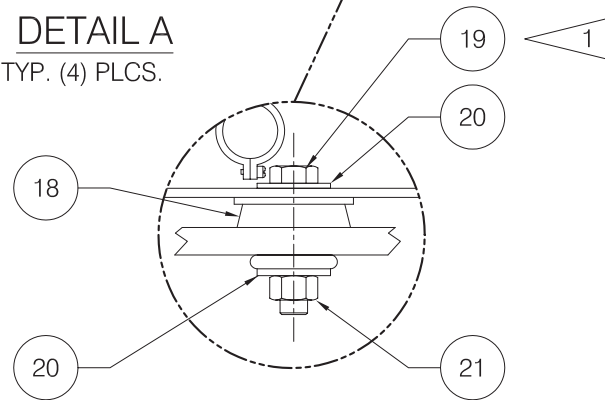

NOTES:

- 1 TORQUE BOLTS TO 195 FT LBS.
- 2 SEAL W/ SILICON SEALER
- 3 TEMPORARILY SUPPORT ITEM 85 WHILE TERMINATING ITEM 58. ONCE WIRING IS COMPLETE LAY JUNCTION BOX ON COWL FLOOR IN PREPARATION FOR MATING TO CAB ASS'Y;
- 4 SEE M/S FOR SEAT INSTALLATION;

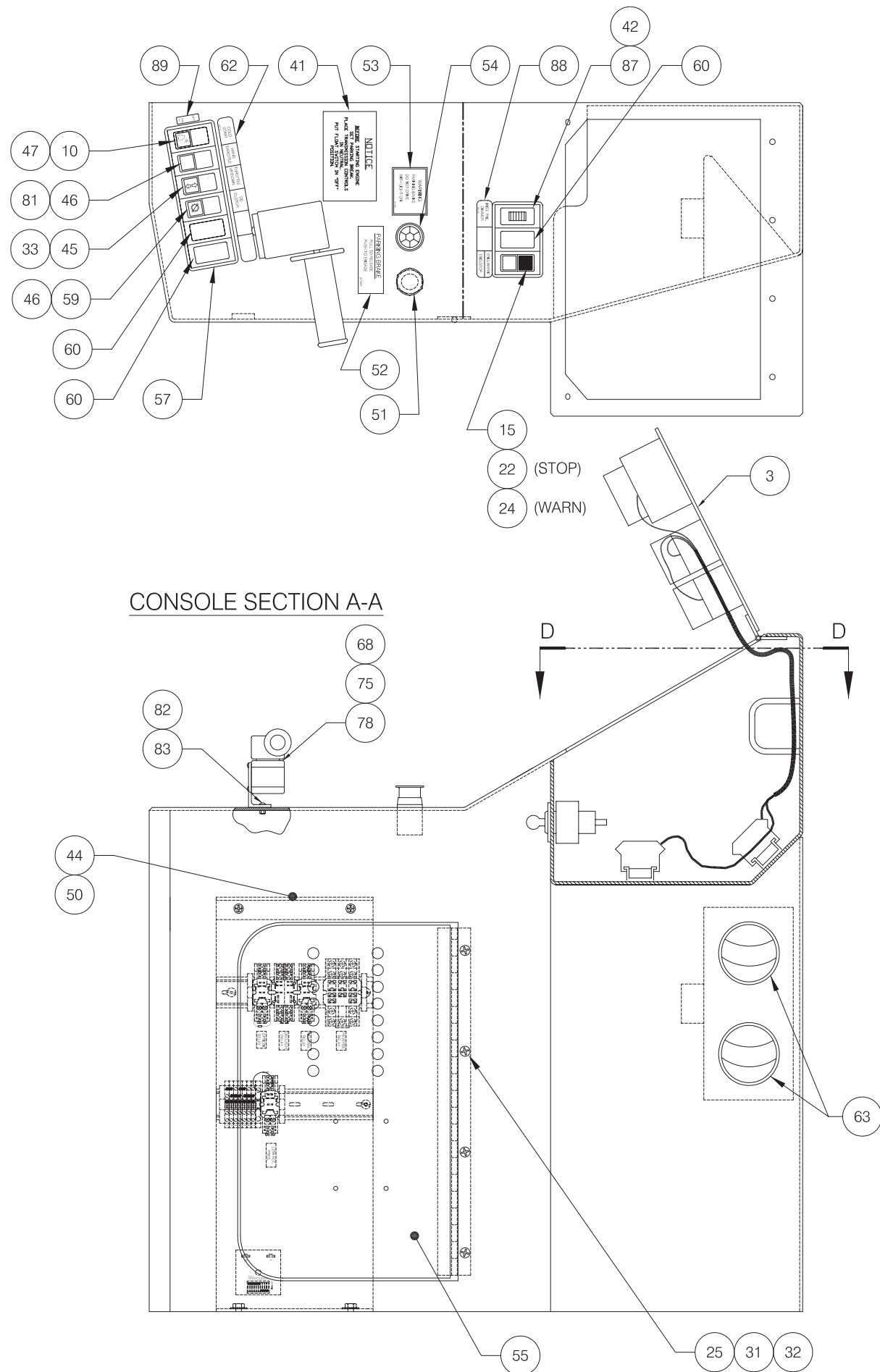

NOTES:

5 REFER TO ELECTRICAL SCHEMATIC FOR TERMINAL DESIGNATION JUMPER REQUIREMENTS AND WIRING INFORMATION;

