

---

Driveline Installation

## Driveline Installation

Item	Part No.	Qty	Description	Item	Part No.	Qty	Description
	<b>580948</b>		<b>Driveline Installation</b>				
1	00106267	4	. Flat Washer	12	00271611	4	. Capscrew
2	* 249020	1	. Driveline Assembly	13	00106268	8	. Flat Washer
3	* 249025	1	. Driveline Assembly	14	223188	4	. Nut, Esna
4	529630	1	. Bracket	15	557039	1	. Bracket
5	00271562	2	. Capscrew	16	201634	8	. Capscrew
6	00274821	2	. Nut, Esna	17	223654	8	. Nut, Esna
7	528830	1	. Shield	18	578691	1	. Plateguard
8	230614	16	. Capscrew	19	578782	1	. Plateguard
9	522154	1	. Guard				
10	577193	1	. Bracket				
11	563451	2	. Angle				
							* See Separate Coverage

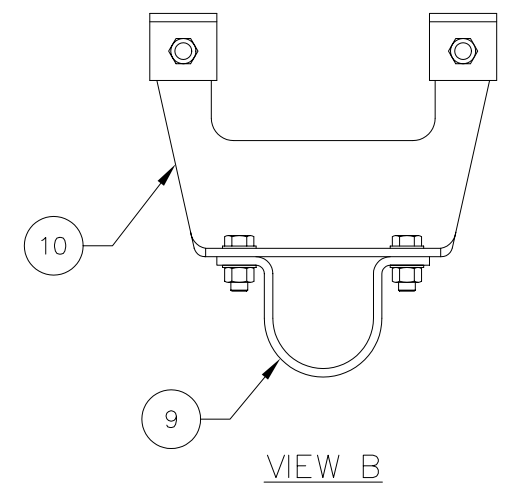
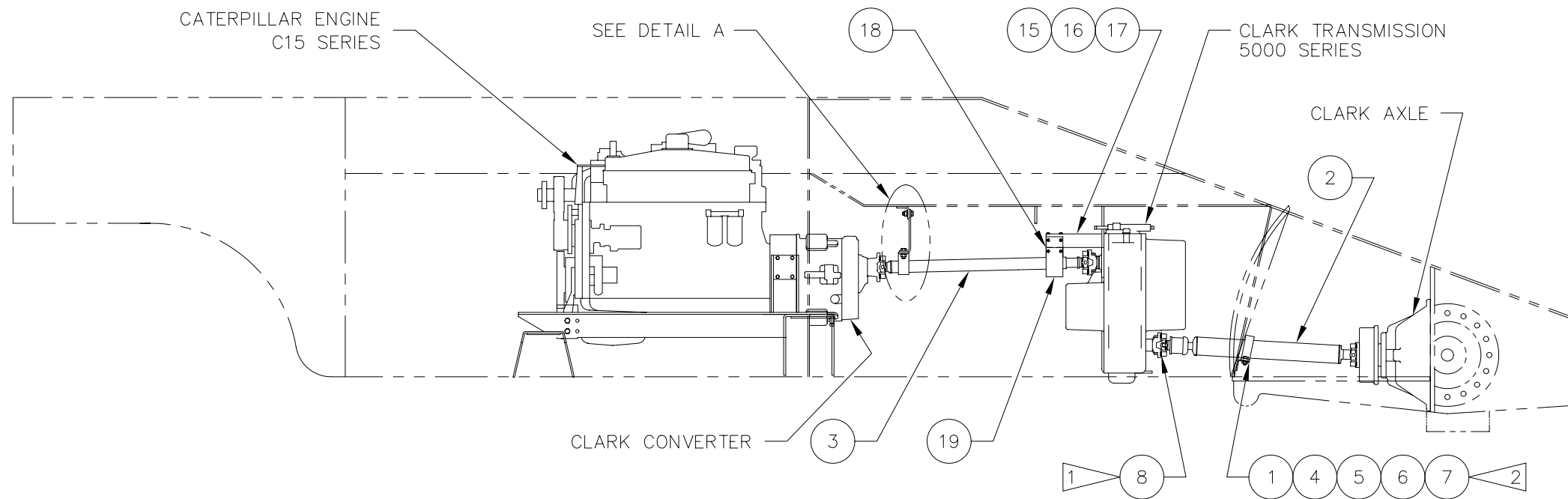
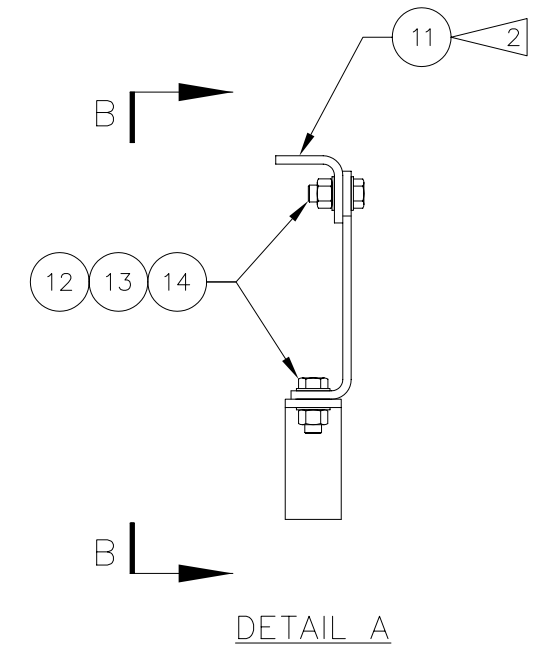
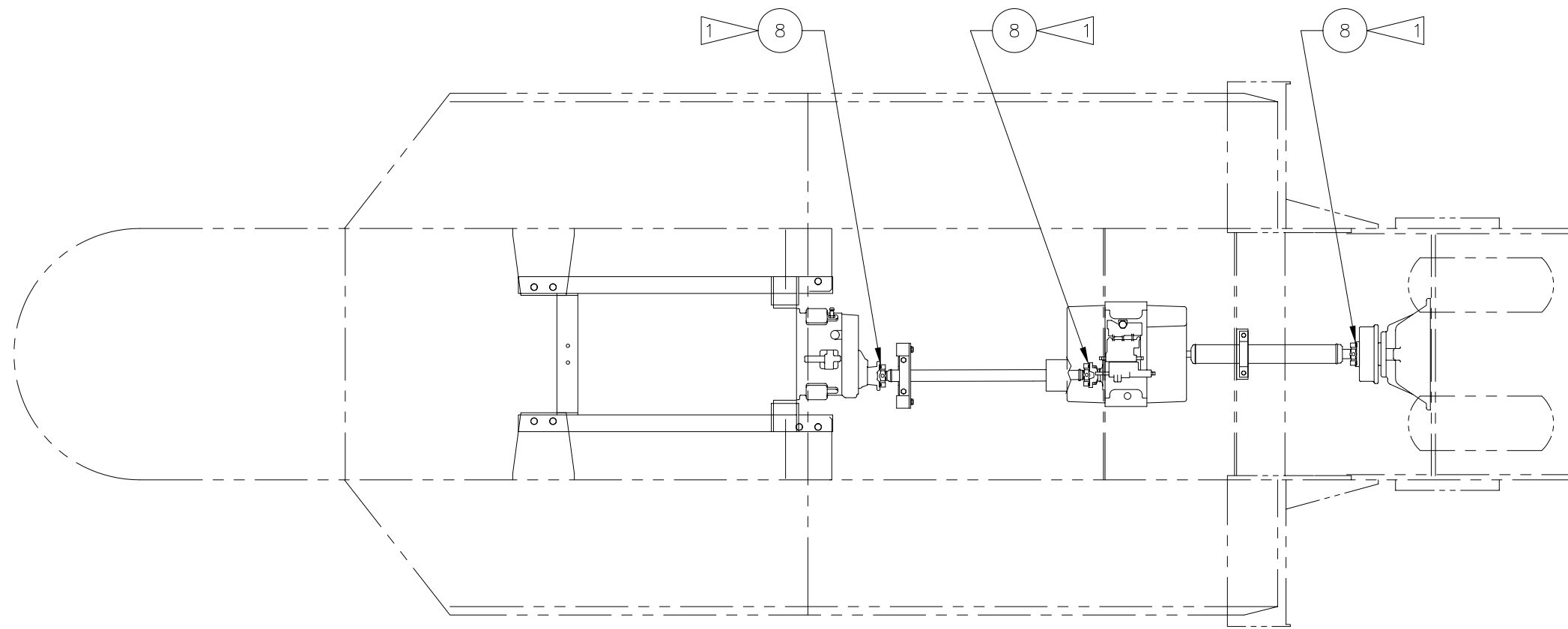

1 TORQUE TO 120 FT/LB.

2 REFERENCE DRAWING ONLY; SEE UNIT MASTER SHEET PARTS CALL OUT.