

Compressor Installation

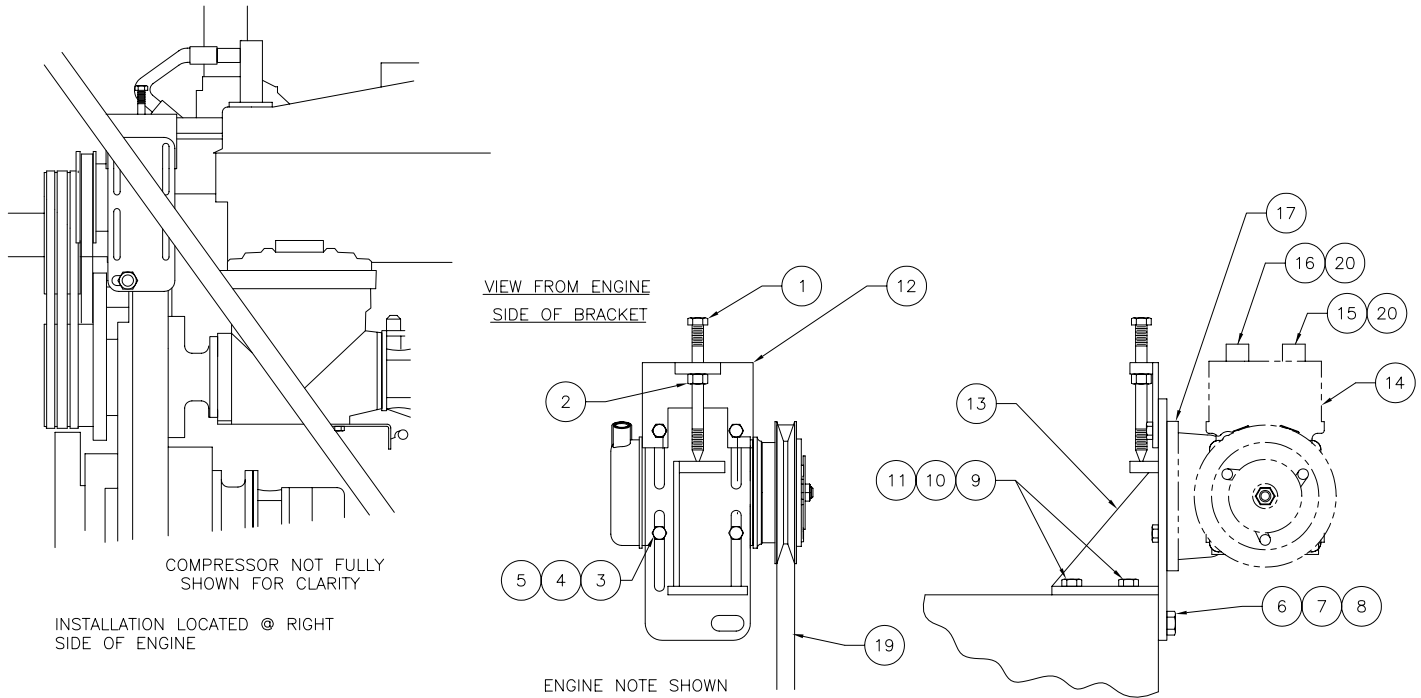

NOTE: INSTL. FOR CUMMINS NTA-855-C ENGINE.
 SYSTEM DESIGNED FOR REFRIGERANT R-134a
 USE REFRIGERANT OIL, P/N 238728
 FOR INSTALATION REQUIREMENTS.

Item	Part No.	Qty	Description	Item	Part No.	Qty	Description
580576 Compressor Installation							
1	557836	1	. Screw, Adj	11	200604	2	. Lockwasher
2	00102637	1	. Hex Nut	12	557835	1	. Bracket Assembly
3	201604	6	. Capscrew	13	571850	1	. Bracket Weldment, A/C
4	201567	6	. Lockwasher	14	239826	1	. Compressor
5	231106	6	. Hex Nut	15	238548	1	. Valve, Compressor
6	201638	1	. Capscrew	16	238547	1	. Valve, Compressor
7	00103325	1	. Lockwasher	17	239979	1	. Bracket, Adapter
8	00106267	1	. Flat Washer	18	581096	1	. Guard Weldment, Belt
9	201618	2	. Capscrew	19	215696	1	. Belt
10	00103343	2	. Flat Washer	20	R10664	2	. O-Ring