

Air Conditioner/Heater Installation

Air Conditioner/Heater Installation

Item	Part No.	Qty	Description	Item	Part No.	Qty	Description
	580575		Air Cond/Heater Installation				
1	* 575065	1	. Heater/AC Assembly	29	238550	1	. Hose End
2	230521	10	. Capscrew		R10664	1	. . O-Ring
3	00103339	12	. Flat Washer	30	* 580576	1	. Compressor Installation
4	574552	1	. Platecover	31	238548	1	. Valve, Compressor
5	233025	1	. Filter Assembly, Air	32	238547	1	. Valve, Compressor
6	231114	44"	. Weatherstrip	33	R10664	2	. O-Ring
7	572532	1	. Decal	34	R10569	1	. Drier, Receiver
8	233268	6'	. Hose, Air	35	224209	2	. Nut, Esna
9	233269	3	. Clamp	36	238537	1	. Hose End
10	R840286	2	. Louver	37	238538	1	. Hose End
11	238385	1	. Gasket	38	239100	1	. Condenser
12	219386	6'	. Wire	39	R840240	1	. Bracket
13	219433	6'	. Wire	40	231611	3	. Capscrew
14	219434	6'	. Wire	41	223428	15	. Flat Washer
15	238543	1	. Hose End	42	232939	9	. Nut, Esna
16	238542	1	. Hose End	43	222600	3	. Capscrew
17	238613	20'	. Hose, Air Cond	44	240143	3	. Capscrew
18	238611	36'	. Hose, Air Cond	45	581011	1	. Bracket
19	203190	48'	. Hose, Heater	46	574203	1	. Hinge
20	201431	4	. Hose Clamp	47	R10657	1	. Switch, Pressure
21	209697	8	. Clamp	48	240504	2	. Hose End
22	209588	12	. Clamp	49	238646	1	. Duct, Hose
23	209695	6	. Clamp	50	581010	1	. Bracket
24	230282	26	. Flat Washer	51	R1632459	1	. Reducer, Rubber
25	223654	26	. Nut, Esna	52	568139	1	. Tube
26	238612	10'	. Hose, Air Cond	53	239225	1	. Hose Clamp
27	238728	1CAN	. Oil, Refrigerant				
28	238549	1	. Hose End				
	R10663	1	. . O-Ring				

* See Separate Coverage

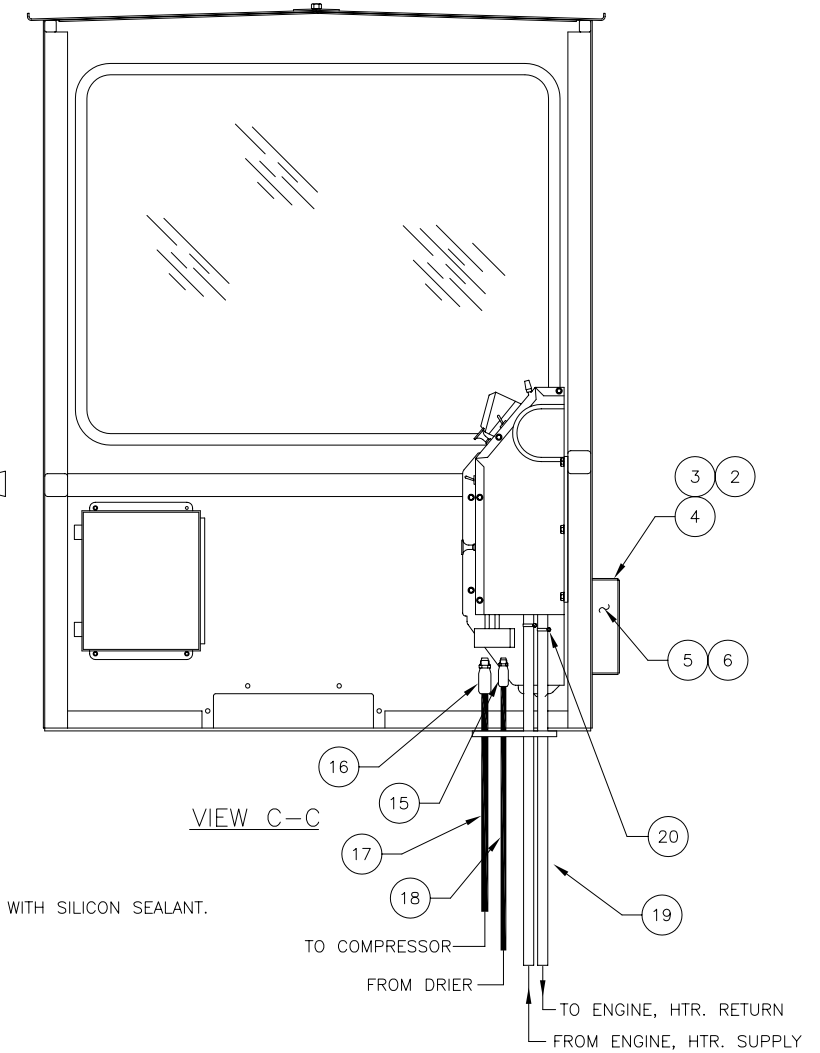
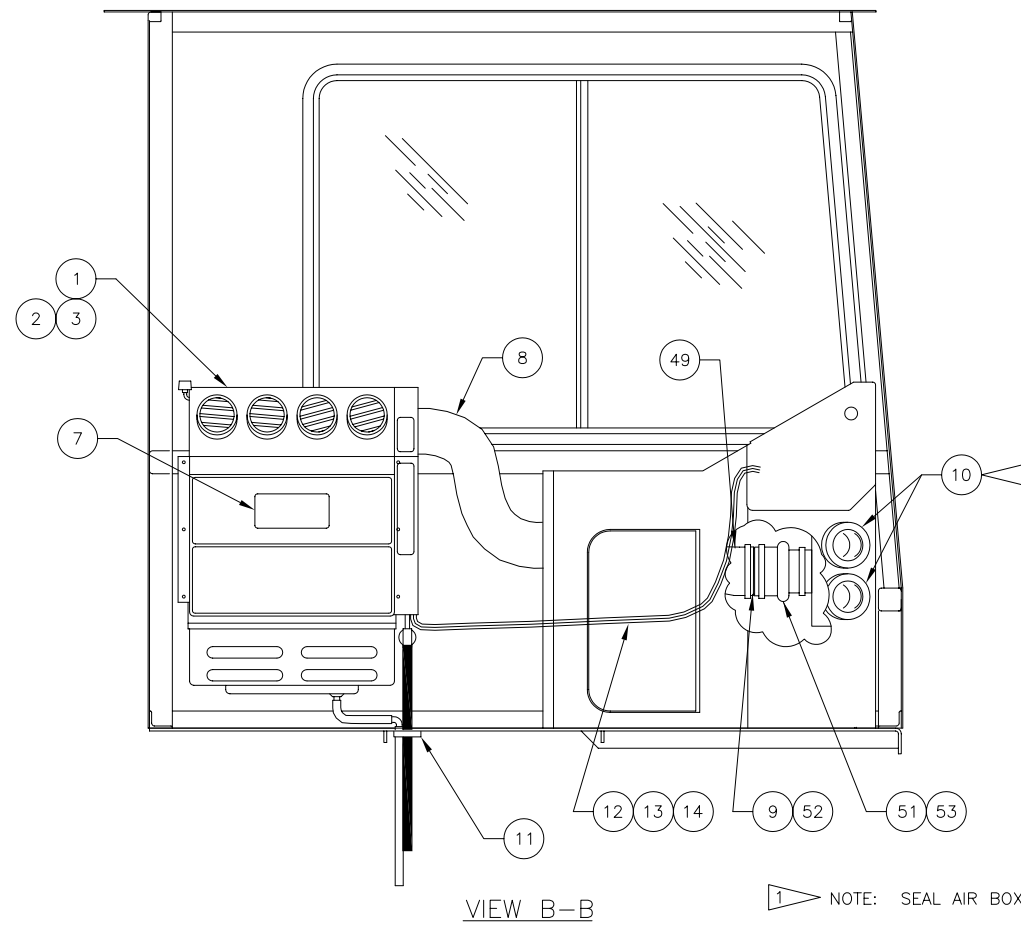
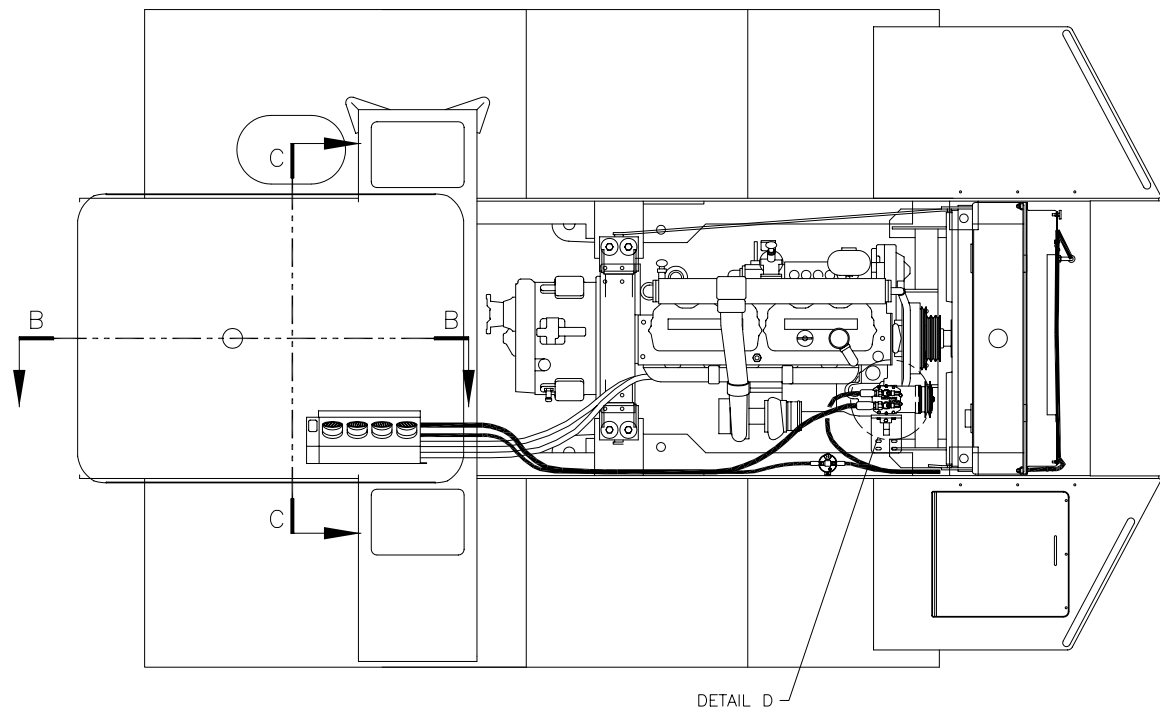

NOTE: SEAL AIR BOX WITH SILICON SEALANT.

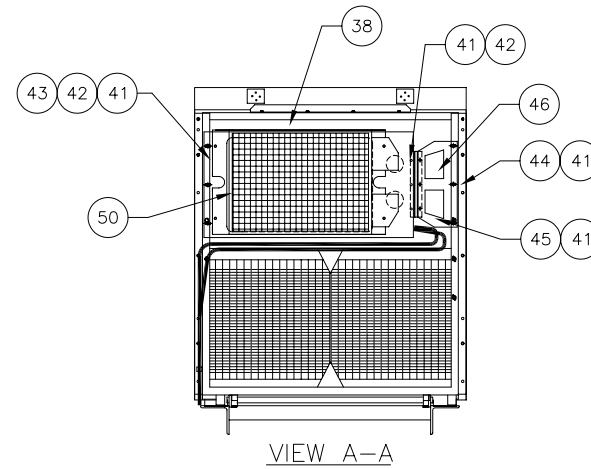
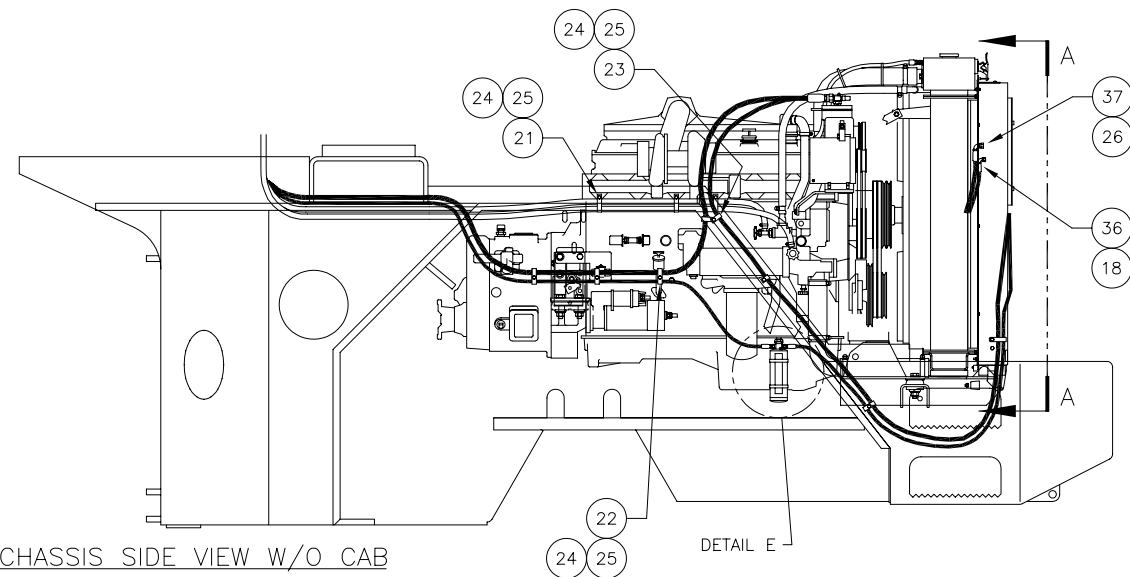

NOTE: INSTL. FOR CAT 3406 ENGINE.

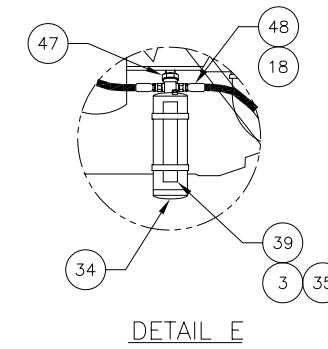
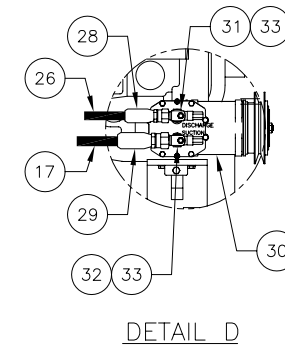

SYSTEM DESIGNED FOR REFRIGERANT R-134A
USE REFRIGERANT OIL, P/N 238728, (27)
FOR TOPPING OFF COMPRESSOR & HOSE ASSY.