

Power Unit

Power Unit

Item	Part No.	Qty	Description	Item	Part No.	Qty	Description
	580302		Power Unit				
1	* 249545	1	. Engine	67	229450	3	. Kit, Split Flange
2	* 246855	1	. Radiator	68	201458	2	. Fitting
3	* 248962	1	. Converter	69	12721	1	. Kit, Split Flange
4	570775	1	. Ring Gear Assembly		200604	4	. . Lockwasher
	237315	96	. . Washer		209538	2	. . Clamp Half
	237316	24	. . Nut		222379	4	. . Capscrew
	570735	1	. . Ring Gear	70	201615	12	. Capscrew
	570776	24	. . Stud	71	201568	12	. Lockwasher
5	* 234183	1	. Alternator	74	R13811086	6	. Capscrew
6	580503	1	. Manifold	75	202947	2	. Hose Clamp
7	529449	1	. Wire Assembly, Grnd	76	243488	4	. Connector
8	581113	1	. Wire Harness, Engine Ecm	77	243489	8	. Clamp
9	581137	1	. Wire Harness	78	580509	1	. Tube
10	578953	1	. Wire Harness, Oem	79	211791	5'	. Hose, Radiator
11	578954	1	. Wire Harness, Engine Access	80	232881	8	. T-Bolt Clamp
13	246987	1	. Fan, 40	81	579333	1	. Tube, Lower Rad
15	580587	1	. Air Scoop	82	580389	1	. Tube
16	* 249406	2	. Pump	83	580390	1	. Tube
17	* 249546	1	. Pump	84	580504	2	. Engine Mt Weldment, Rear
18	539968	1	. Sleeve, Pump	87	R13811123	10	. Capscrew
21	505499	3	. Gasket	91	219383	8'	. Wire
23	206320	6'	. Hose, Bulk	92	219392	7'	. Loom, Auto
24	247072	2	. Fitting	93	209578	8	. Clamp
25	580421	1	. Engine Mt	94	R1939857	6	. Bracket
26	R13811148	2	. Capscrew	95	579536	1	. Bar, Mtg
27	R13811457	4	. Flat Washer	96	236805	10	. Capscrew
28	224194	2	. Nut	97	R13801005	10	. Lockwasher
29	R13811075	6	. Capscrew	98	234177	2	. Capscrew
30	R13811451	8	. Washer	99	223871	2	. Lockwasher
31	R13812516	14	. Lockwasher	100	219404	2'	. Wire
32	R13811122	6	. Capscrew	101	228776	3	. Terminal Ring
33	R13042	10	. Flat Washer	102	203341	1	. Terminal Ring
34	R13809066	20	. Lockwasher	103	243553	1	. Fitting
35	203274	2	. Shutoff Valve	104	200247	3	. Terminal Ring
36	12930006	2	. Fitting	105	219435	2'	. Wire
37	R13811037	4	. Capscrew	106	219408	1'	. Wire
38	R13806980	4	. Washer	107	229301	1	. Relay
39	R13802575	12	. Lockwasher	108	225129	1	. Fitting
40	249309	1	. Compressor	110	229449	1	. Kit, Split Flange
41	249805	1	. Belt, Serpentine	111	23390	3	. Kit, Split Flange
42	247230	1	. Belt, Serpentine		200604	4	. . Lockwasher
43	R13801909	1	. Capscrew		201621	4	. . Capscrew
44	223587	1	. Nut		203523	1	. . O-Ring
45	R13090	1	. Capscrew		209539	2	. . Clamp Half
46	578732	1	. Fitting	112	223642	2	. Fitting
47	209486	2	. Fitting	113	222886	1	. Fitting
48	211561	1	. Fitting	114	245629	3	. Fitting
49	R13811121	4	. Capscrew	115	220095	1	. Fitting
50	R13811077	4	. Capscrew	116	211560	1	. Fitting
51	00120396	14	. Washer	117	223436	1	. Fitting
52	201611	2	. Capscrew	118	248624	1	. Fitting
53	205128	2	. Lockwasher	119	580395	1	. Angle, Lh
56	203519	1	. O-Ring	120	580396	1	. Angle, Rh
57	201635	6	. Capscrew	121	209752	1	. Fitting
58	230596	3	. Capscrew	122	224202	4	. Nut
59	223909	4	. Lockwasher	123	214130	2	. Fitting
60	14274	1	. Fitting	129	209406	4	. Fitting
61	11767	1	. Kit, Split Flange	131	579242	2	. Bracket
	200604	4	. . Lockwasher	132	579325	2	. Lifting Eye
	209537	2	. . Clamp Half	133	* 580644	1	. Engine Oil Fill
	222379	4	. . Capscrew	134	580646	1	. Dipstick & Hsg Assembly
62	217657	1	. Fitting	135	R13811033	8	. Capscrew
63	209997	1	. Fitting	136	R13803897	2	. Capscrew
64	225057	1	. Fitting	137	R13805224	2	. Capscrew
65	209619	1	. Fitting	138	226149	4	. Lockwasher
66	211693	1	. Fitting				

Power Unit (continued)

Item	Part No.	Qty	Description	Item	Part No.	Qty	Description
	580302		Power Unit (cont)				
139	234588	8	. Capscrew				
140	233477	8	. Lockwasher				
141	R13812665	8	. Washer				

* See Separate Coverage

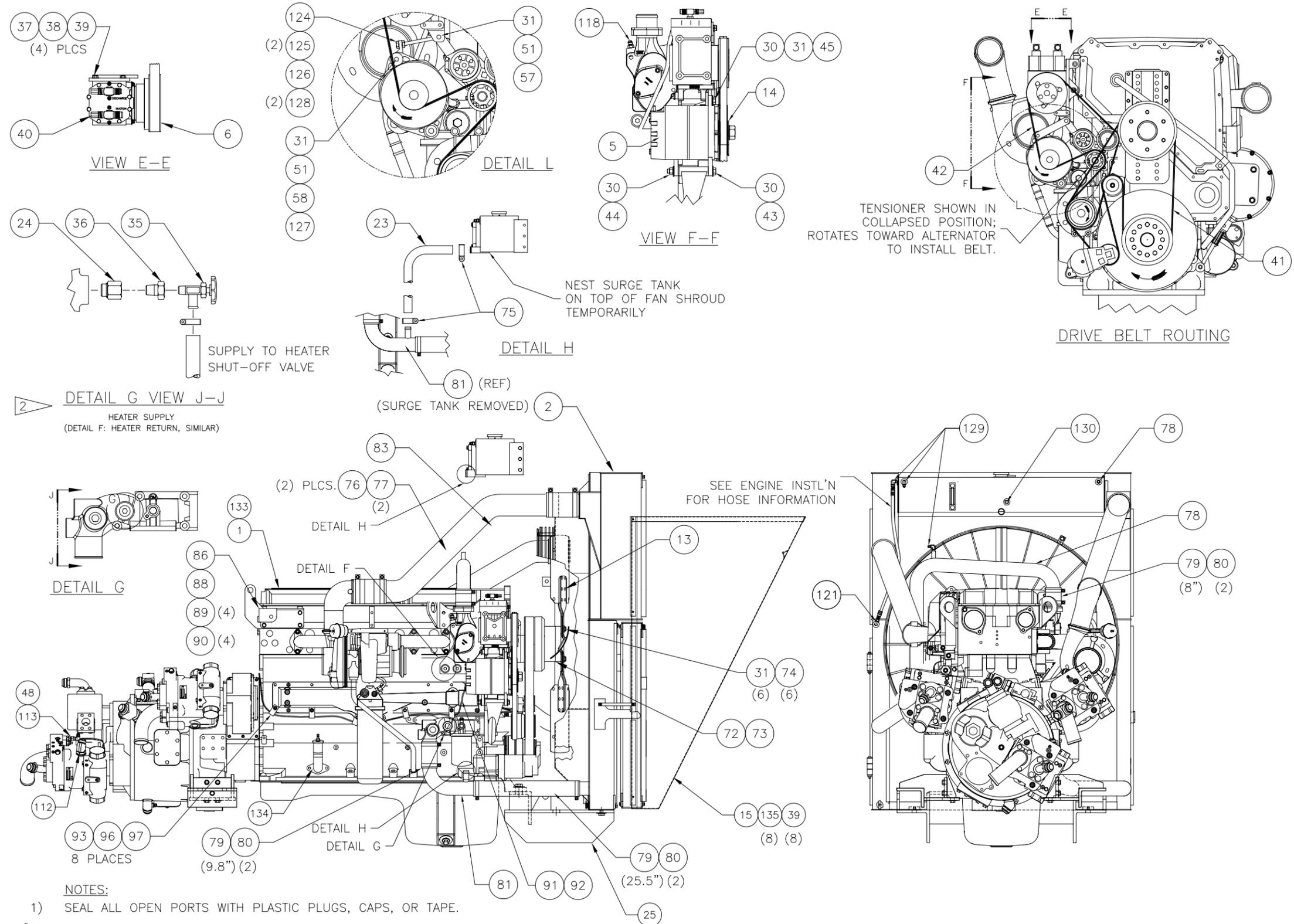

- 1) SEAL ALL OPEN PORTS WITH PLASTIC PLUGS, CAPS, OR TAPE.
- 2) REFER TO THE UNIT MASTER SHEET FOR THE CAB HEATER/AIR CONDITIONER PARTS LIST FOR CONTINUATION OF PLUMBING.
- 3) CAUTION: NO LINES OTHER THAN THE VENT LINES ARE TO BE PLUMBED TO THE TOP TANK OR ENGINE VENT PORTS. THESE LINES ARE NOT TO RISE ABOVE THE RADIATOR VENT PORTS OR HAVE ANY LOOPS THAT COULD TRAP AIR.
- 4) INSTALL PUMP (ITEM 15) WITH CASE DRAIN ORIENTED UP
- 5) FOR CLARITY, SUPPORTS, FITTINGS AND CONNECTIONS ARE NOT SHOWN IN ALL VIEWS;

TENSIONER SHOWN IN COLLAPSED POSITION; ROTATES TOWARD ALTERNATOR TO INSTALL BELT.

