

---

Axle Installation

## Axle Installation W/Disk Brake

Item	Part No.	Qty	Description	Item	Part No.	Qty	Description
	<b>580231</b>		<b>Axle Installation W/Disc Brake</b>				
1	00223911	32	. Capscrew	16	545335	2	. Driver, Disc Brake
2	18622W	12	. Capscrew	17	545526	2	. Bar, Guard
3	223188	12	. Locknut	18	547338	2	. Axle Shaft
4	200268	1	. Breather	19	* 587932	4	. Caliper Assembly
5	201319	2	. Plug, Magnetic	20	552656	2	. Bracket
6	204882	148	. Washer	21	552657	2	. Bracket
7	248620	24	. Hard Washer	22	553569	2	. Axle Ext
8	221719W	68	. Hex Nut	23	236308	A/R	. Silicone, Superflex Ultra Blue
9	218760	80	. Capscrew	24	580625	2	. Bracket
10	* 580699	1	. Kit, Axle	25	223433	24	. Nut, Esna
11	219246	24	. Stud	26	209918	2	. Fitting
12	227807	1	. Fitting	27	222689	A/R	. Threadlock, Anaerobic
13	544408	2	. Plate, Disc Brake	28	244264	A/R	. Anti-Seize, Copper Grade
14	225851	32	. Hard Washer	29	*a 209919	1	. Fitting
15	545267	2	. Shim	30	R13811436	24	. Hard Washer
				31	242864	1 GAL	. Additive; Lube

\* See Separate Coverage

\*a Use as required. Some axle housings will have a hole on top for an alternate breather location.

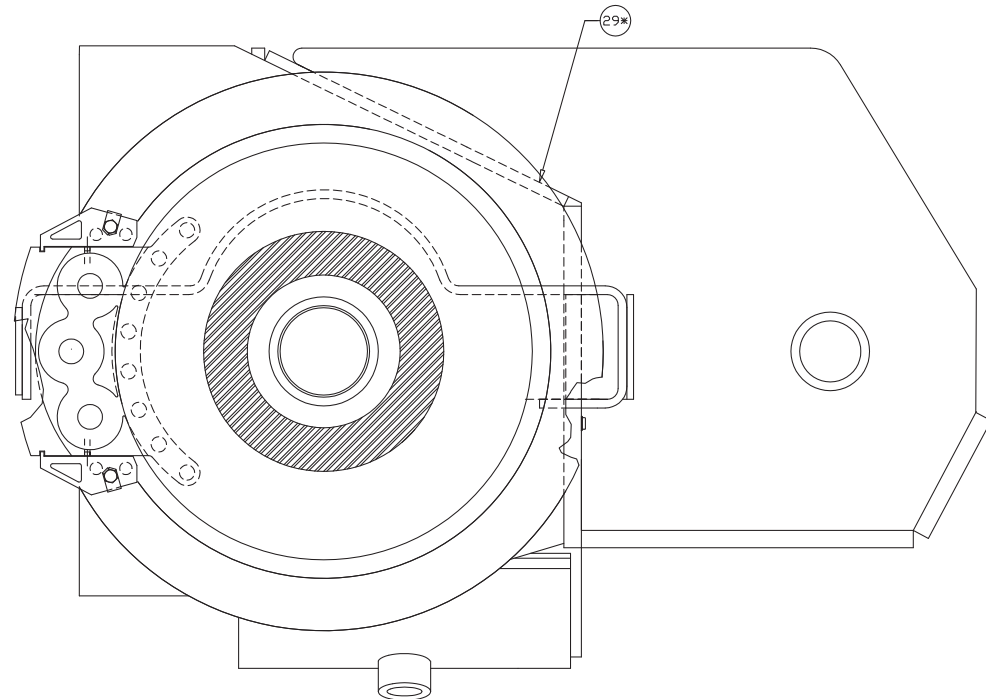
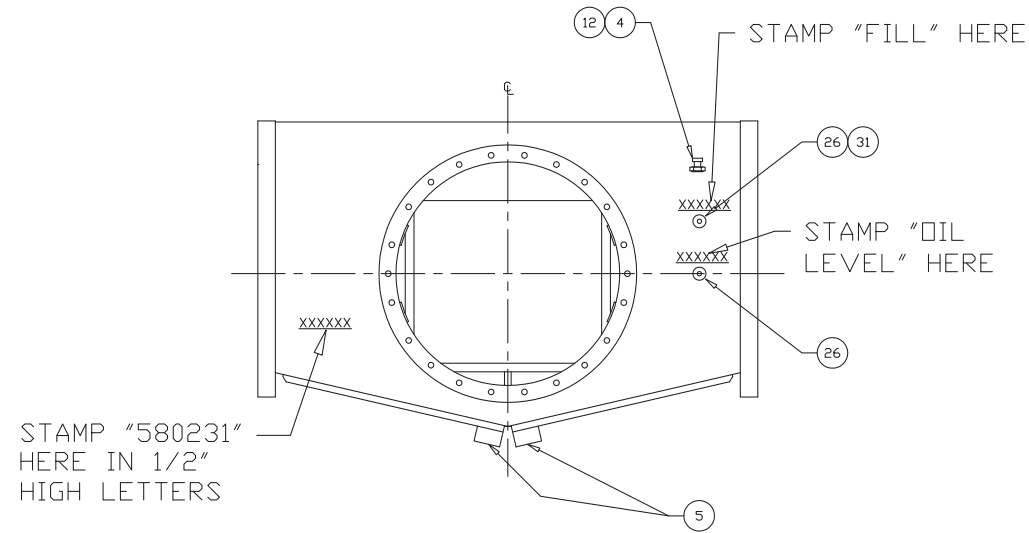

FRONT BRAKE REMOVED

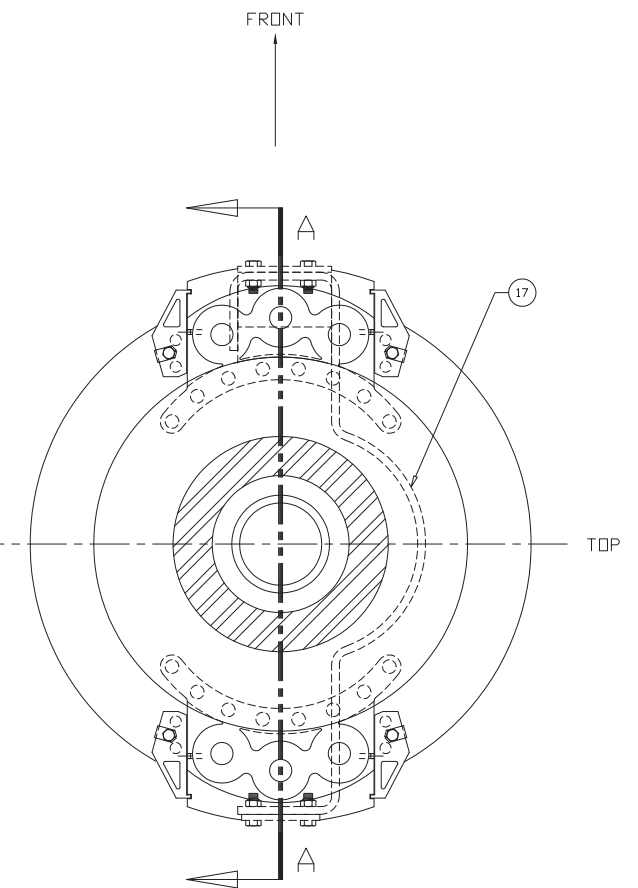
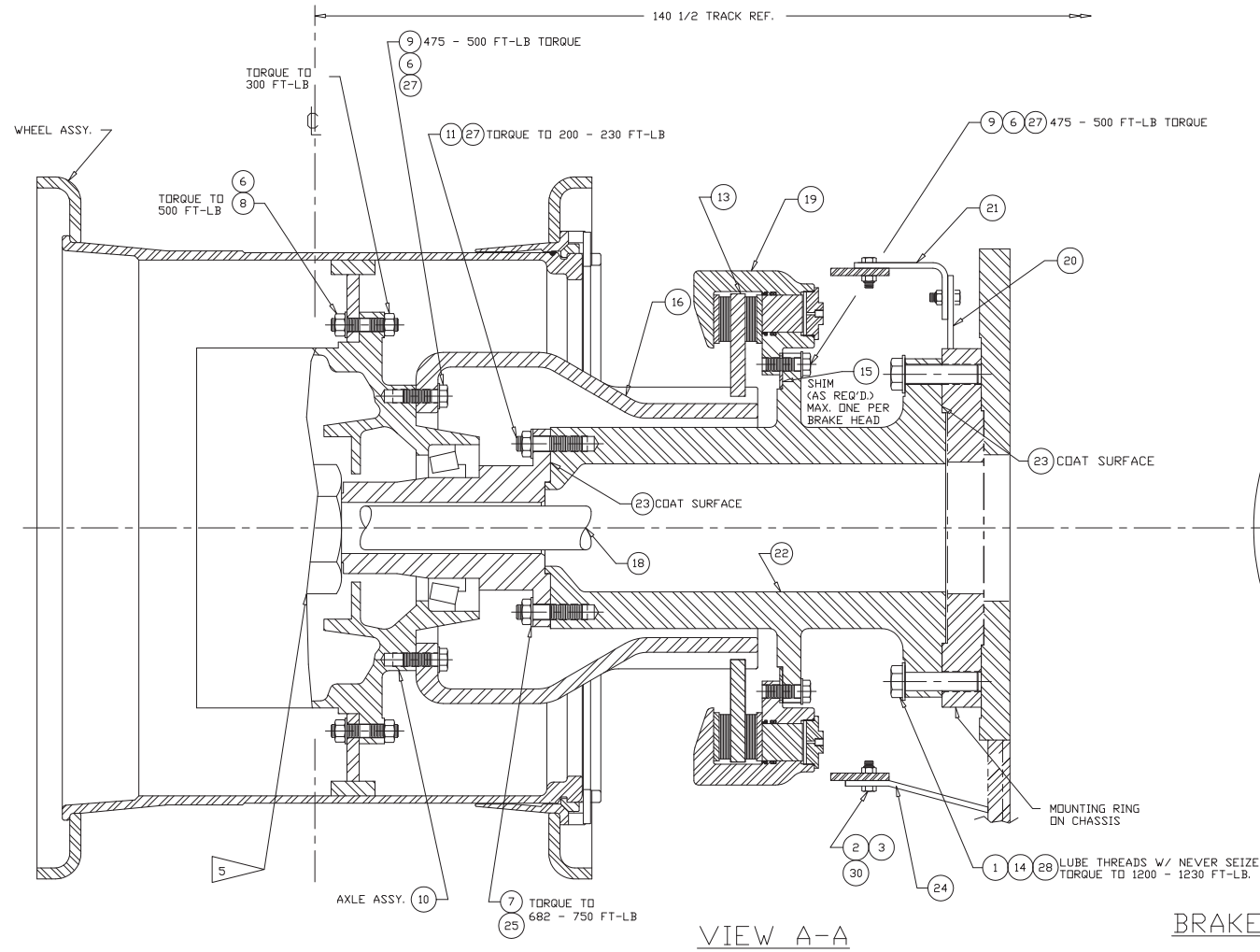

BRAKES & BRAKE TUBE GUARD

WHEEL ASSY. NOT SHOWN

**NOTES:**

1. MOUNT AXLE HOUSING SO THAT CALIPERS WILL BE LOCATED FRONT AND REAR.
3. READ AND FOLLOW RF554828 BURNISH INSTRUCTIONS WHENEVER NEW BRAKE PADS ARE INSTALLED.
4. DIFFERENTIAL AND CARRIER MUST BE MOUNTED WITH THE RING GEAR ON THE LEFT HAND SIDE OF THE PINION (INPUT SHAFT) WHEN VIEWED FROM THE INPUT DRIVE YOKE.
5. AXLE KIT (ITEM 10) CONTAINS ITEMS WHICH ARE REFERENCED ITEM BUBBLES. SEE CLARK AXLE INSTALLATION INSTRUCTIONS. (PUBLICATIONS FORM 80-1041)