

Driveline Installation

Driveline Installation

Item	Part No.	Qty	Description	Item	Part No.	Qty	Description
	580187		Driveline Installation				
1	* 248963	1	. Driveline Assembly	15	200604	8	. Lockwasher
2	* 248964	1	. Driveline Assembly	16	00191758	1	. Fitting, Lube
3	* 577120	1	. Driveline Assembly	17	00103397	1	. Cotter Pin
4	* 248965	1	. Driveline Assembly	18	222615	2	. Flat Washer
5	524169	1	. Retainer, Bearing	19	201635	2	. Capscrew
6	204585	1	. Bearing, Roller	23	579933	1	. Yoke, Splined
7	577194	1	. Plateguard	24	504068	1	. Nut, Slotted
8	201604	4	. Capscrew	25	235608	1	. Hard Washer
9	223654	4	. Nut, Esna	26	580184	1	. Plate, Adapter
10	223427	4	. Flat Washer	27	14122	6	. Capscrew
11	224813	28	. Capscrew	28	226149	6	. Lockwasher
13	215166	2	. Seal				
14	223086	6	. Capscrew				

* See Separate Coverage

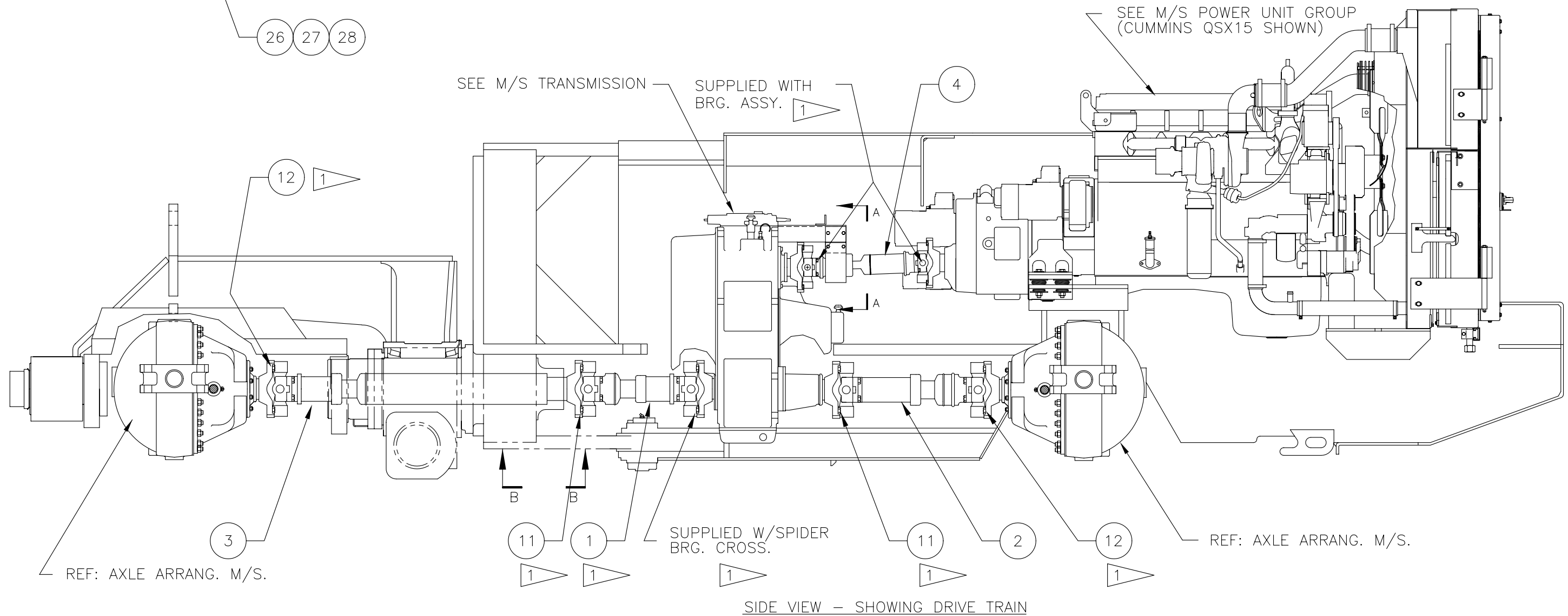
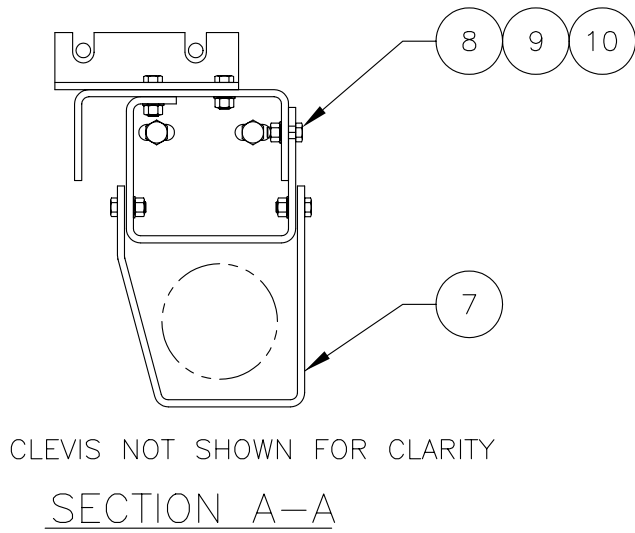
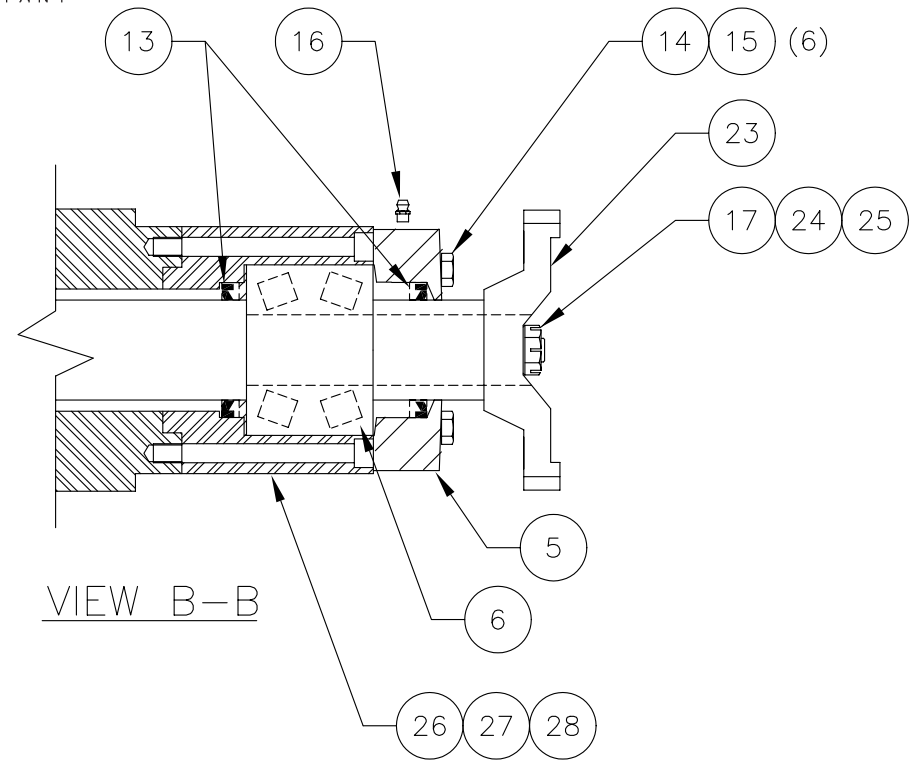

1 TORQUE 1/2"-20 NF BOLTS BETWEEN 110-130 FT. LBS.