

BRAKE BUTTON INSTALLATION

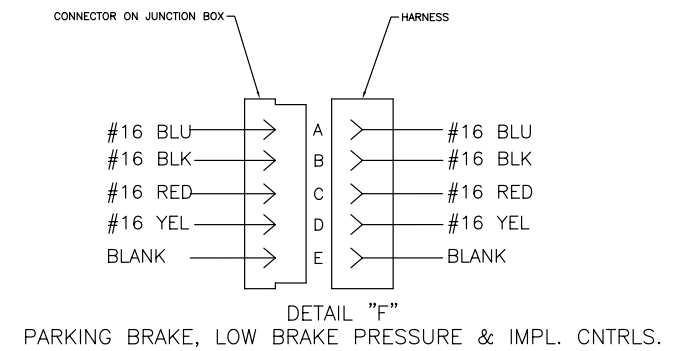
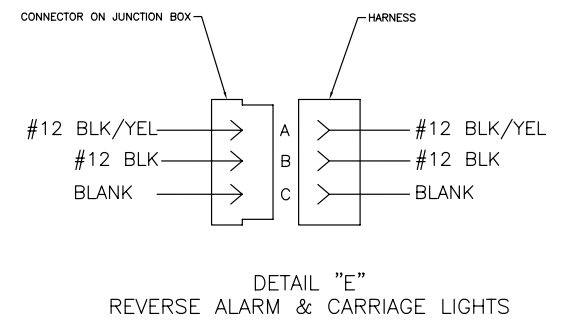
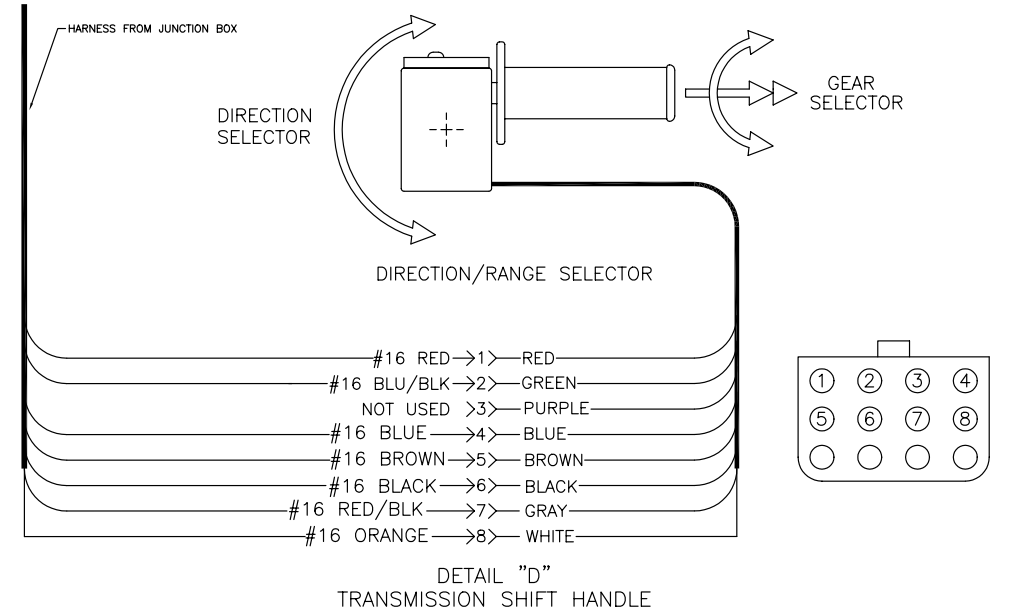
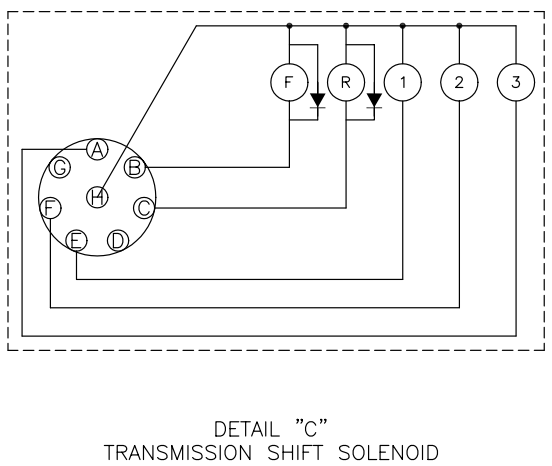
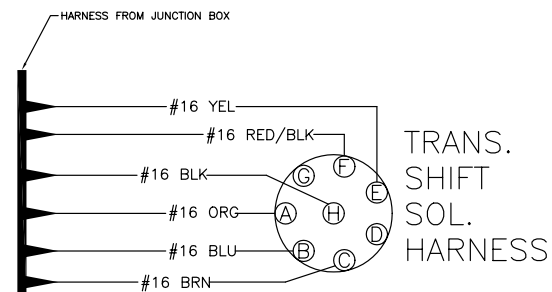
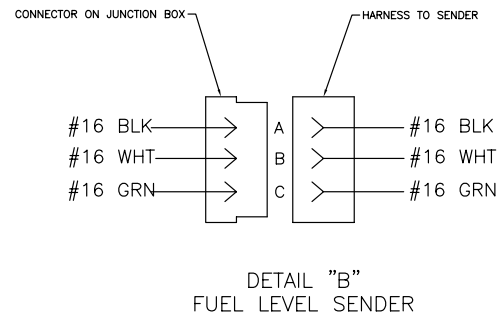
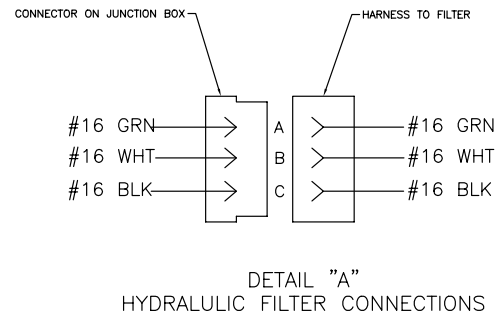
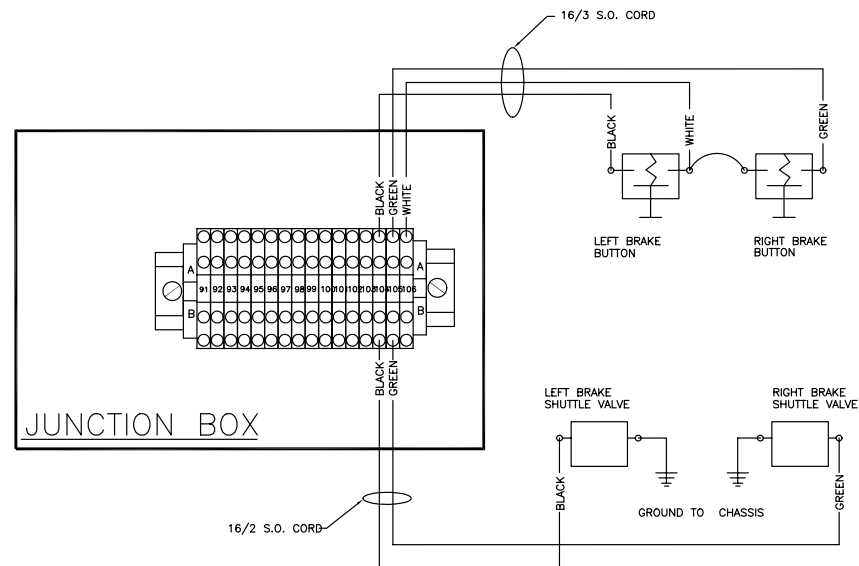

NOTE: ALL WIRE TO BE #16 AWG UNLESS OTHERWISE SPECIFIED.